

ESD PROTECTION DEVICE

STAND-OFF VOLTAGE – 3.3 Volts
POWER DISSIPATION – 90 WATTS

GENERAL DESCRIPTION

L09ESD3V3CE2 is designed to replace multilayer varistors (MLVs) in portable applications where low operating voltage is vital. They offer superior electrical characteristics such as lower clamping voltage and no device degradation when compared to MLVs. They are designed to protect sensitive semiconductor components from damage or upset due to electrostatic discharge (ESD), lightning, electrical fast transients (EFT), and cable discharge events (CDE).

FEATURES

- Protects one power or I/O line
- Max. peak pulse power : Ppp = 90W at tp = 8/20 us.
- Low clamping voltage
- IEC 61000-4-2, (ESD) > ±20KV (air) ; > ±10KV (contact)
- Qualified to AEC-Q101 Rev. C

APPLICATION

- Cellular Handsets & Accessories
- Notebooks & Handhelds
- Portable Instrumentation
- Digital Cameras
- Peripherals
- MP3 Players

MECHANICAL DATA

- Case Material: "Green" molding compound UL flammability classification 94V-0 (No Br,Sb, Cl)
- Moisture Sensitivity: Leve 1 per J-STD-020C
- Component in accordance to RoHs 2011/65/EU

SOD-882

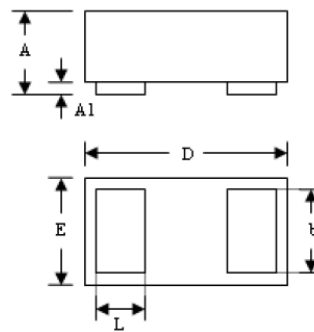

SOD-882		
DIM.	MIN.	MAX.
A	0.47	0.53
A1	0.00	0.05
b	0.25	0.55
D	0.95	1.075
E	0.55	0.675
L	0.20	0.45

All Dimensions in millimeter

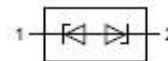

PIN ASSIGNMENT	
1	Cathode
2	Cathode

MAXIMUM RATINGS (Tj= 25°C unless otherwise noticed)

Rating	Symbol	Value	Unit
Peak Pulse Power (tp = 8/20us)	Ppk	90	W
Peak Pulse Current (tp = 8/20us)	Ipp	5	A
Operating Junction Temperature Range	TJ	-55 to + 125	°C
Storage Temperature Range	Tstg	-55 to + 150	°C
Soldering Temperature, t max = 10s	TL	260	°C

ELECTRICAL CHARACTERISTICS (Tj= 25°C unless otherwise noticed)

Parameter	Symbol	Conditions	Min	Typ	Max	Unit
Reverse standoff voltage	V _{RWM}		---	---	3.3	V
Punch Through Voltage	V _{PT}	I _{SB} = 2uA	3.5	---	---	V
Snap-Back Voltage	V _{SB}	I _{SB} = 50 mA	2.8	---	---	V
Reverse leakage current	I _{RM}	V _{DRM} = 3.3V	---	0.05	0.5	uA
Clamping Voltage	V _C	I _{PP} = 1A, tp = 8/20µs	---	6.0	8.0	V
Clamping Voltage	V _C	I _{PP} = 5 A, tp = 8/20µs	---	8.5	18	V
Junction capacitance	C _J	V _R = 0V, f = 1MHz	---	11	15	pF

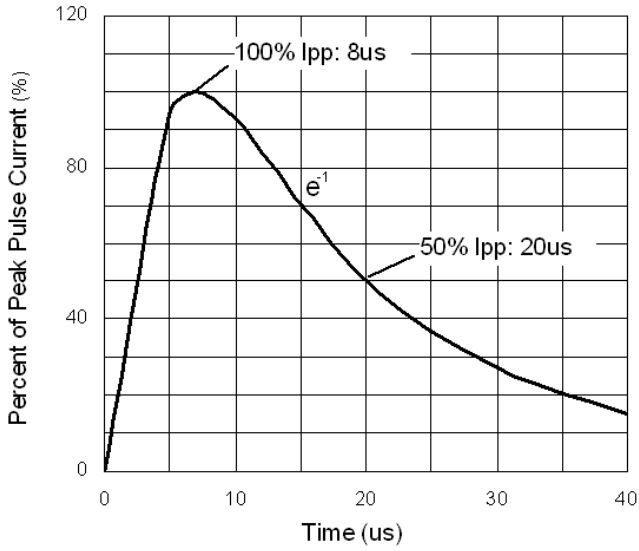

Figure 1. 8/20 us pulse waveform according to IEC 61000-4-5

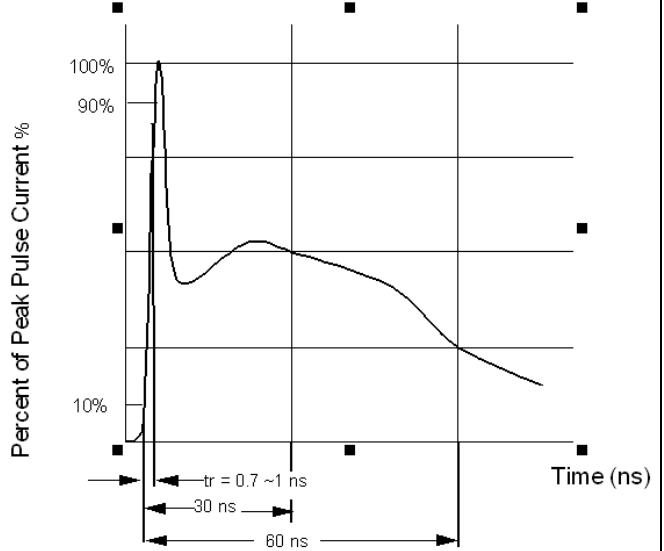

Figure 2. ESD pulse waveform according to IEC 61000-4-2

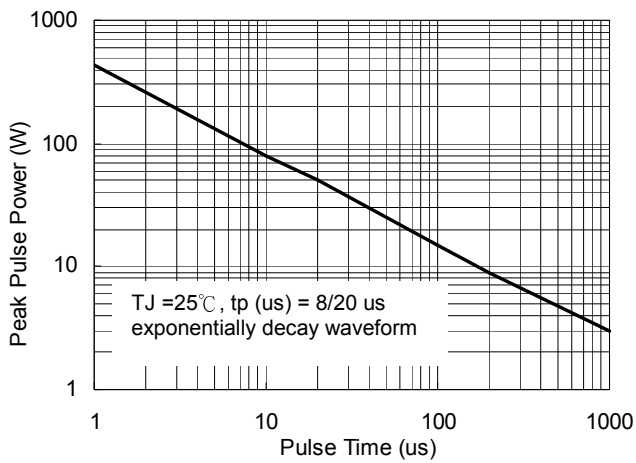

Figure 3. Power Dissipation versus Pulse Time

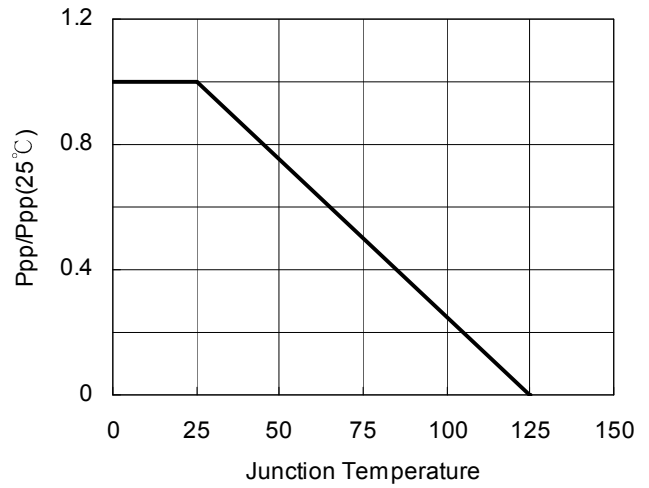

Figure 4. Peak pulse power versus TJ

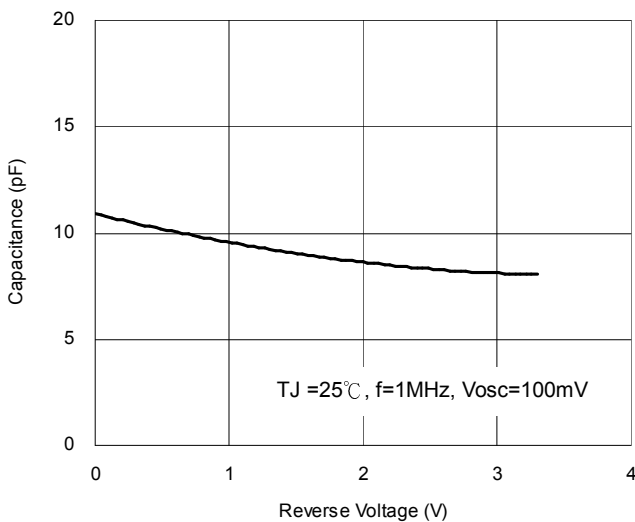

Figure 5. Typical Junction Capacitance

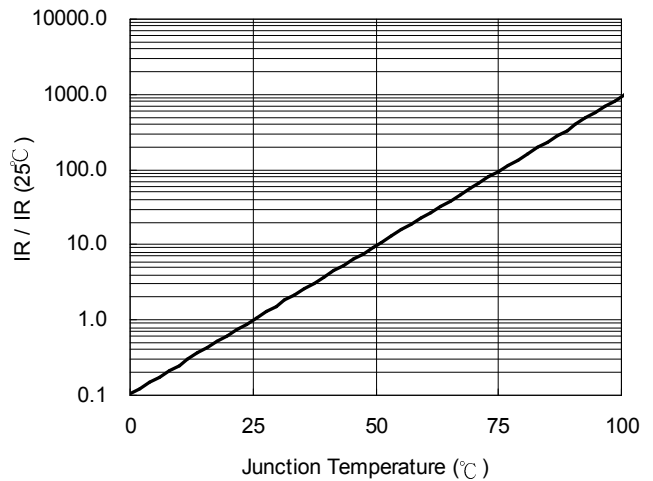

Figure 6. Reverse Leakage Current versus TJ

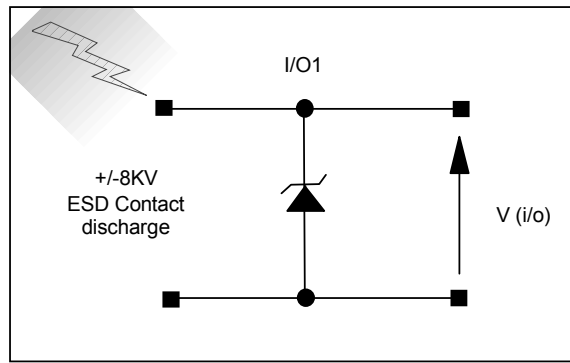

Figure 7. ESD Test Configuration

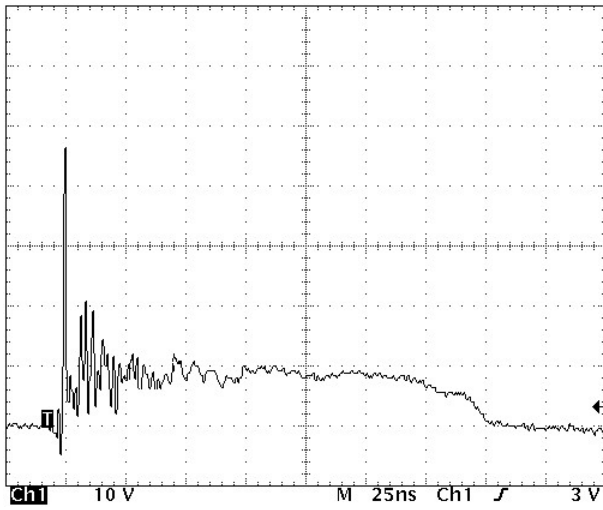

Figure 8. Clamped +8 kV ESD voltage waveform

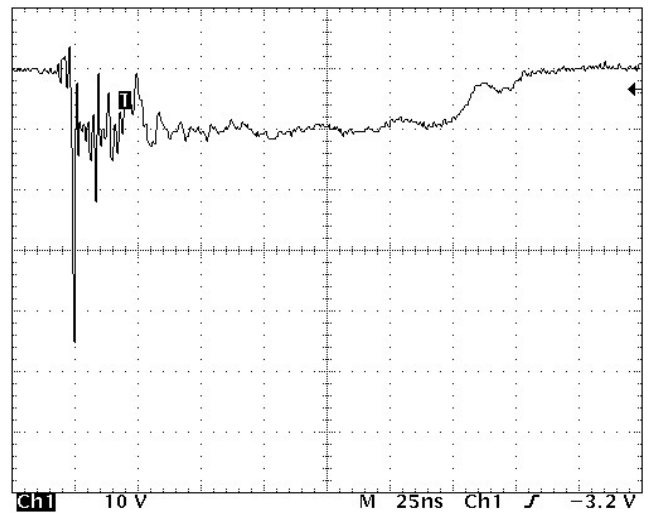
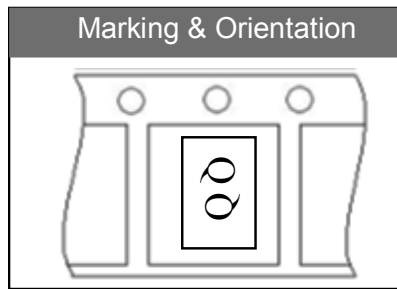

Figure 9. Clamped -8 kV ESD voltage waveform

Marking & Orientation



Packaging Information

DEVICE	Q'TY/REEL (PCS)	REEL DIA. (INCH)	Q'TY/BOX (PCS)	Q'TY/CARTON (PCS)
L09ESD3V3CE2	10K	7	150K	300K

SOD-882 Soldering Pad Layout

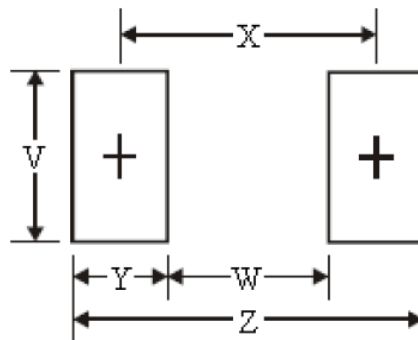

Dim.	Millimeters	Inches
Z	1.30	0.051
X	0.75	0.029
W	0.20	0.007
Y	0.55	0.021
V	0.80	0.031

Important Notice and Disclaimer

LSC reserves the right to make changes to this document and its products and specifications at any time without notice. Customers should obtain and confirm the latest product information and specifications before final design, purchase or use.

LSC makes no warranty, representation or guarantee regarding the suitability of its products for any particular purpose, nor does LSC assume any liability for application assistance or customer product design. LSC does not warrant or accept any liability with products which are purchased or used for any unintended or unauthorized application.

No license is granted by implication or otherwise under any intellectual property rights of LSC.

LSC products are not authorized for use as critical components in life support devices or systems without express written approval of LSC.