

**UNIDIRECTIONAL ESD PROTECTION DIODE**

STAND-OFF VOLTAGE - **5.0 Volts**  
POWER DISSIPATION - **25 WATTS**

**GENERAL DESCRIPTION**

- The L02ESD5V0D6-5 is a low capacitance 5-fold ESD protection diode array in SOT363 package.

**FEATURES**

- Uni-directional ESD protection of five lines.
- Bi-directional ESD protection of up four lines.
- Max.peak pulse power : Ppp = 25W at tp = 8/20 us
- ESD protection > 20 KV
- IEC 61000-4-2, level 4 ( ESD ), > 15KV ( air ) ; > 8KV ( contact ).
- IEC 61000-4-5 ( surge ); Ipp = 2.5A at tp = 8/20 us.
- Low clamping voltage; Vcl < 12V at Ipp = 2.5A
- Low capacitance device.

**APPLICATION**

- Computers and peripherals.
- Communication system.
- Cellular handsets and accessories.
- Audio & video equipment.

**MECHANICAL DATA**

- Case Material: "Green" molding compound UL flammability classification 94V-0 (No Br.Sb, Cl)
- Terminals: Lead Free Plating (Matte Tin Finish)
- Component in accordance to RoHs 2002/95/EC

**SOT363**

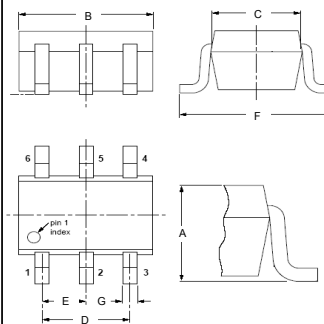

SOT363		
DIM.	MIN.	MAX.
A	0.80	1.10
B	1.80	2.20
C	1.15	1.40
D	1.30 (Typ.)	
E	0.65 (Typ.)	
F	2.00	2.45
G	0.15	0.35

All Dimensions in millimeter

PIN ASSIGNMENT	
1	Cathode 1
2	Common Anode
3	Cathode 2
4	Cathode 3
5	Cathode 4
6	Cathode 5

**Marking & Orientation**

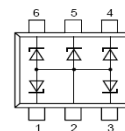
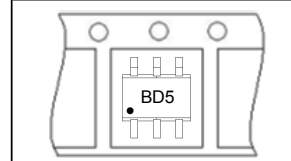

**MAXIMUM RATINGS (Tj= 25°C unless otherwise noticed)**

Rating	Symbol	Value	Unit
Peak pulse Power ( 8/20us Waveform ) , Notes (1,2)	PPPM	25	W
Operating Junction Temperature Range	TJ	-55 to + 150	°C
Storage Temperature Range	Tstg	-55 to + 150	°C
Soldering Temperature, t max = 10s	TL	260	°C

**ELECTRICAL CHARACTERISTICS (Tj= 25°C unless otherwise noticed)**

Parameter	Symbol	Conditions	Min	Max	Unit
Reverse standoff voltage	VDRM	---	---	5.0	V
Reverse leakage current	IRM	VDRM = 5 V	---	25	nA
Breakdown voltage	VBR	IR = 1 mA	6.4	7.2	V
Diode capacitance	CJ	VR = 0 V , f = 1MHz	---	19	pF
Clamping voltage	VCL	Ipp = 1A	---	10	V
Clamping voltage	VCL	Ipp = 2.5A	---	12	V

- NOTE:**1. Non-repetitive current pulse 8/20 us exponentially decaying waveform.  
2. Measured from any of pins 1,3,4,5 or 6 to pin2.

REV. 3, Oct-2010, KSIR11

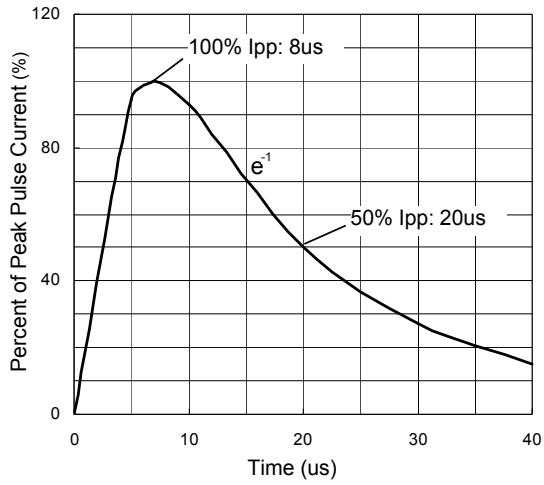

Figure 1. 8/20 us pulse waveform according to IEC 61000-4-5

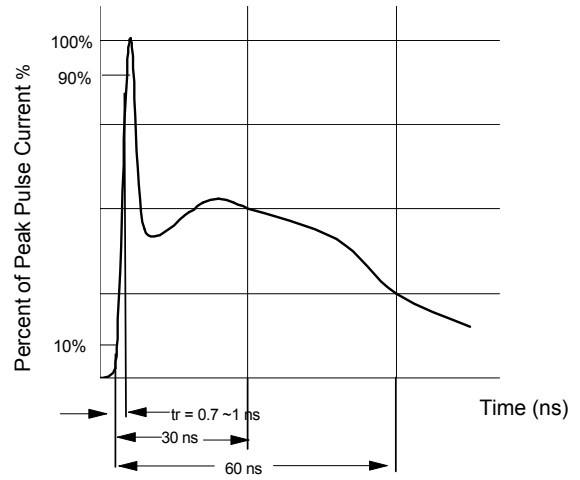

Figure 2. ESD pulse waveform according to IEC 61000-4-2

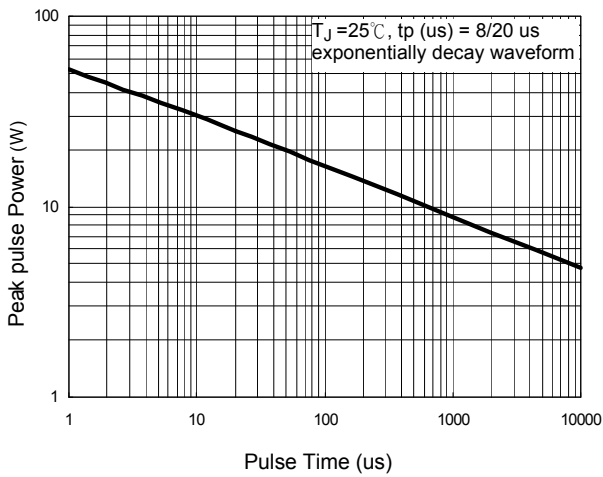

Figure 3. Power Dissipation versus Pulse Time

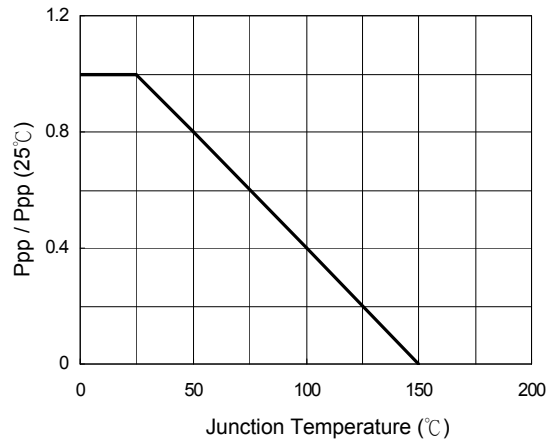

Figure 4. Peak pulse power versus  $T_J$

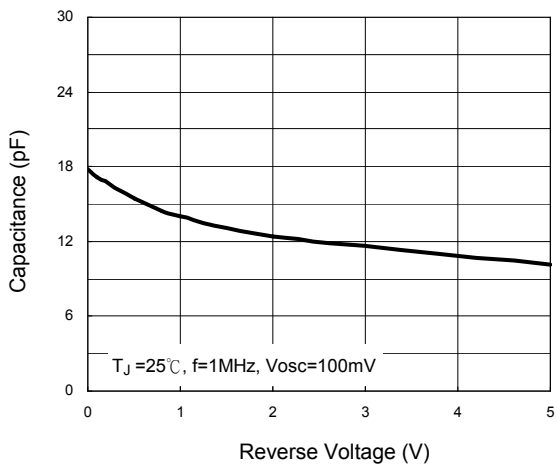

Figure 5. Typical Junction Capacitance

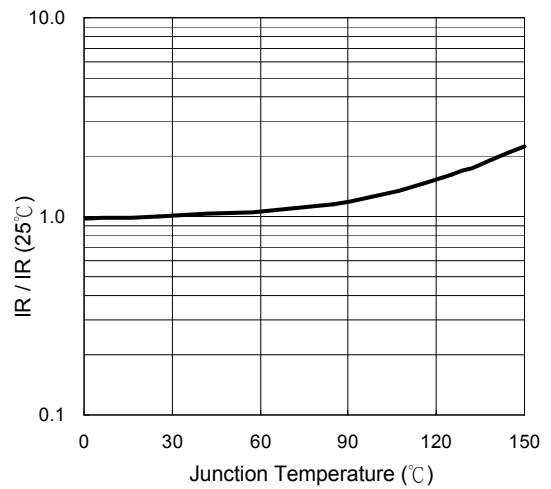

Figure 6. Reverse Leakage Current versus  $T_J$

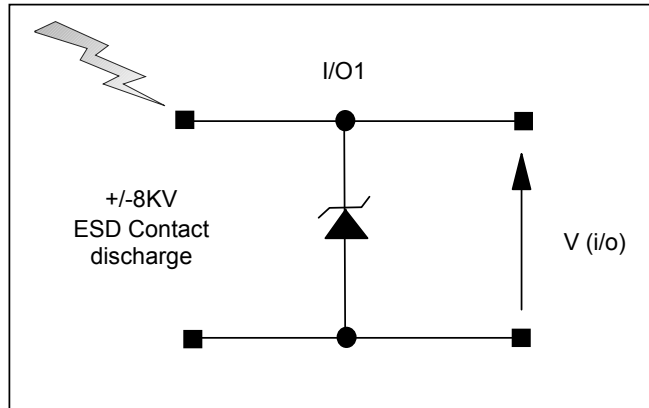

Figure 7. ESD Test Configuration

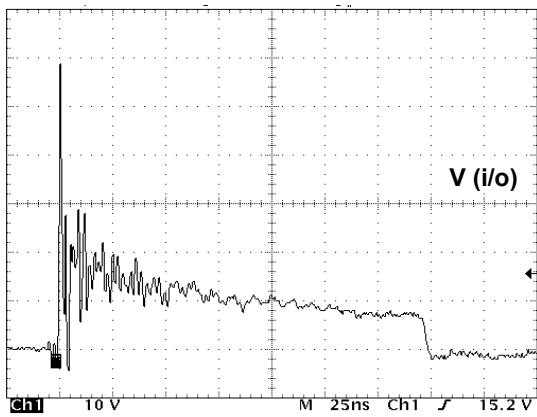

Figure 8. Clamped +8 kV ESD voltage waveform

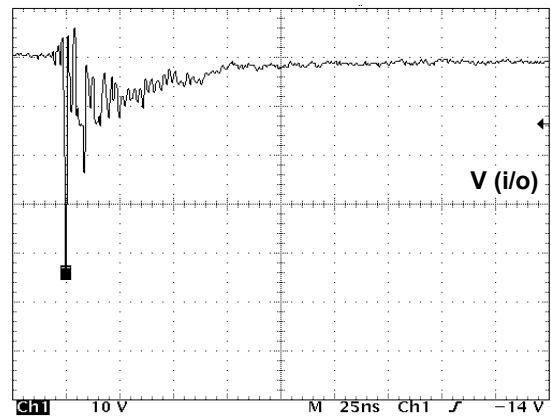

Figure 9. Clamped -8 kV ESD voltage waveform

## **Important Notice and Disclaimer**

LSC reserves the right to make changes to this document and its products and specifications at any time without notice. Customers should obtain and confirm the latest product information and specifications before final design, purchase or use.

LSC makes no warranty, representation or guarantee regarding the suitability of its products for any particular purpose, nor does LSC assume any liability for application assistance or customer product design. LSC does not warrant or accept any liability with products which are purchased or used for any unintended or unauthorized application.

No license is granted by implication or otherwise under any intellectual property rights of LSC.

LSC products are not authorized for use as critical components in life support devices or systems without express written approval of LSC.