



# KSZ9021GN

## Gigabit Ethernet Transceiver with GMII / MII Support

### General Description

The KSZ9021GN is a completely integrated triple speed (10Base-T/100Base-TX/1000Base-T) Ethernet Physical Layer Transceiver for transmission and reception of data on standard CAT-5 unshielded twisted pair (UTP) cable.

The KSZ9021GN provides the industry standard GMII/MII (Gigabit Media Independent Interface / Media Independent Interface) for connection to GMII/MII MACs in Gigabit Ethernet Processors and Switches for data transfer at 1000 Mbps or 10/100Mbps speed.

The KSZ9021GN reduces board cost and simplifies board layout by using on-chip termination resistors for the four differential pairs and by integrating a LDO controller to drive a low cost MOSFET to supply the 1.2V core.

The KSZ9021GN provides diagnostic features to facilitate system bring-up and debugging in production testing and in product deployment. Parametric NAND tree support enables fault detection between KSZ9021 I/Os and board. Micrel LinkMD<sup>®</sup> TDR-based cable diagnostics permit identification of faulty copper cabling. Remote and local loopback functions provide verification of analog and digital data paths.

The KSZ9021GN is available in a 64-pin, lead-free QFN package (See Ordering Information).

### Features

- Single-chip 10/100/1000Mbps IEEE 802.3 compliant Ethernet Transceiver
- GMII/MII standard compliant interface
- Auto-negotiation to automatically select the highest link up speed (10/100/100Mbps) and duplex (half/full)
- On-chip termination resistors for the differential pairs
- On-chip LDO controller to support single 3.3V supply operation – requires only external FET to generate 1.2V for the core
- Jumbo frame support up to 16KB
- 125MHz Reference Clock Output
- Programmable LED outputs for link, activity and speed
- Baseline Wander Correction
- LinkMD<sup>®</sup> TDR-based cable diagnostics for identification of faulty copper cabling
- Parametric NAND Tree support for fault detection between chip I/Os and board.
- Loopback modes for diagnostics
- Automatic MDI/MDI-X crossover for detection and correction of pair swap at all speeds of operation

### Functional Diagram

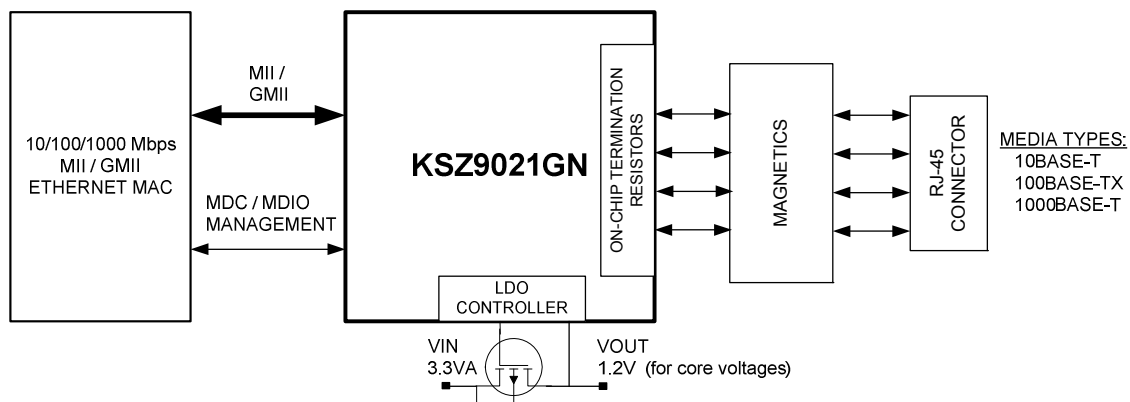

LinkMD is a registered trademark of Micrel, Inc.

## More Features

- Automatic detection and correction of pair swaps, pair skew and pair polarity
- MDC/MDIO Management Interface for PHY register configuration
- Interrupt pin option
- Power down and power saving modes
- Operating Voltages
  - Core: 1.2V (external FET or regulator)
  - I/O: 3.3V or 2.5V
  - Transceiver: 3.3V
- Available in 64-pin QFN (8mm x 8mm) package

## Applications

- Laser/Network Printer
- Network Attached Storage (NAS)
- Network Server
- Gigabit LAN on Motherboard (GLOM)
- Broadband Gateway
- Gigabit SOHO/SMB Router
- IPTV
- IP Set-top Box
- Game Console
- Triple-play (data, voice, video) Media Center
- Media Converter

## Ordering Information

Part Number	Temp. Range	Package	Lead Finish	Description
KSZ9021GN	0°C to 70°C	64-Pin QFN	Pb-Free	GMII / MII, Commercial Temperature
KSZ9021GNI <sup>(1)</sup>	-40°C to 85°C	64-Pin QFN	Pb-Free	GMII / MII, Industrial Temperature

**Note:**

1. Contact factory for lead time.

## Revision History

Revision	Date	Summary of Changes
1.0	10/13/09	Data sheet created
1.1	9/10/10	Added industrial temperature part number KSZ9021GNI. Added support for 2.5V VDD I/O. Added LED drive current. Corrected GMII receive timing for $t_{su}$ . Updated KSZ9021GN pin outs throughout data sheet to reflect pin out changes for silicon revision A3. Updated boilerplate.

## Contents

<b>Pin Configuration</b> .....	<b>8</b>
<b>Pin Description</b> .....	<b>9</b>
<b>Strapping Options</b> .....	<b>14</b>
<b>Functional Overview</b> .....	<b>15</b>
<b>Functional Description: 10Base-T/100Base-TX Transceiver</b> .....	<b>16</b>
100Base-TX Transmit .....	16
100Base-TX Receive .....	16
Scrambler/De-scrambler (100Base-TX only) .....	16
10Base-T Transmit .....	16
10Base-T Receive .....	16
<b>Functional Description: 1000Base-T Transceiver</b> .....	<b>17</b>
Analog Echo Cancellation Circuit .....	17
Automatic Gain Control (AGC) .....	17
Analog-to-Digital Converter (ADC) .....	17
Timing Recovery Circuit .....	18
Adaptive Equalizer .....	18
Trellis Encoder and Decoder .....	18
<b>Functional Description: Additional 10/100/1000 PHY Features</b> .....	<b>18</b>
Auto MDI/MDI-X .....	18
Pair- Swap, Alignment, and Polarity Check .....	19
Wave Shaping, Slew Rate Control and Partial Response .....	19
PLL Clock Synthesizer .....	19
<b>Auto-Negotiation</b> .....	<b>19</b>
<b>GMII Interface</b> .....	<b>21</b>
GMII Signal Definition .....	22
GMII Signal Diagram .....	22
<b>MII Interface</b> .....	<b>23</b>
MII Signal Definition .....	24
MII Signal Diagram .....	24
<b>MII Management (MIIM) Interface</b> .....	<b>25</b>
<b>Interrupt (INT_N)</b> .....	<b>25</b>
<b>LED Mode</b> .....	<b>25</b>
Single LED Mode .....	26
Tri-color Dual LED Mode .....	26
<b>NAND Tree Support</b> .....	<b>27</b>
<b>Power Management</b> .....	<b>28</b>
Power Saving Mode .....	28
Software Power Down Mode .....	28
Chip Power Down Mode .....	28
<b>Register Map</b> .....	<b>29</b>
<b>Register Description</b> .....	<b>30</b>
IEEE Defined Registers .....	30
Vendor Specific Registers .....	36
Extended Registers .....	39

---

<b>Absolute Maximum Ratings</b> .....	<b>41</b>
<b>Operating Ratings</b> .....	<b>41</b>
<b>Electrical Characteristics</b> .....	<b>41</b>
<b>Timing Diagrams</b> .....	<b>44</b>
GMII Transmit Timing.....	44
GMII Receive Timing.....	45
MII Transmit Timing.....	46
MII Receive Timing.....	47
Auto-Negotiation Timing.....	48
MDC/MDIO Timing.....	49
Reset Timing.....	50
<b>Reset Circuit</b> .....	<b>50</b>
<b>Reference Circuits – LED Strap-in Pins</b> .....	<b>51</b>
<b>Reference Clock – Connection and Selection</b> .....	<b>52</b>
<b>Magnetics Specification</b> .....	<b>52</b>
<b>Package Information</b> .....	<b>53</b>

## List of Figures

Figure 1. KSZ9021GN Block Diagram .....	15
Figure 2. KSZ9021GN 1000Base-T Block Diagram – Single Channel.....	17
Figure 3. Auto-Negotiation Flow Chart.....	20
Figure 4. KSZ9021GN GMII Interface.....	22
Figure 5. KSZ9021GN MII Interface .....	24
Figure 6. GMII Transmit Timing – Data Input to PHY .....	44
Figure 7. GMII Receive Timing – Data Input to MAC .....	45
Figure 8. MII Transmit Timing – Data Input to PHY .....	46
Figure 9. MII Receive Timing – Data Input to MAC .....	47
Figure 10. Auto-Negotiation Fast Link Pulse (FLP) Timing .....	48
Figure 11. MDC/MDIO Timing.....	49
Figure 12. Reset Timing.....	50
Figure 13. Recommended Reset Circuit.....	50
Figure 14. Recommended Reset Circuit for Interfacing with CPU/FPGA Reset Output. ....	51
Figure 15. Reference Circuits for LED Strapping Pins.....	51
Figure 16. 25MHz Crystal / Oscillator Reference Clock Connection .....	52

## List of Tables

Table 1. MDI / MDI-X Pin Mapping .....	18
Table 2. Auto-Negotiation Timers .....	21
Table 3. GMII Signal Definition .....	22
Table 4. MII Signal Definition .....	24
Table 5. MII Management Frame Format – for KSZ9021GN .....	25
Table 6: Single LED Mode – Pin Definition .....	26
Table 7: Tri-color Dual LED Mode – Pin Definition .....	26
Table 8. NAND Tree Test Pin Order – for KSZ9021GN .....	27
Table 9. GMII Transmit Timing Parameters .....	44
Table 10. GMII Receive Timing Parameters .....	45
Table 11. MII Transmit Timing Parameters .....	46
Table 12. MII Receive Timing Parameters .....	47
Table 13. Auto-Negotiation Fast Link Pulse (FLP) Timing Parameters .....	48
Table 14. MDC/MDIO Timing Parameters .....	49
Table 15. Reset Timing Parameters .....	50
Table 16. Reference Crystal/Clock Selection Criteria .....	52
Table 17. Magnetics Selection Criteria .....	52
Table 18. Qualified Single Port 10/100/1000 Magnetics .....	52

# Pin Configuration

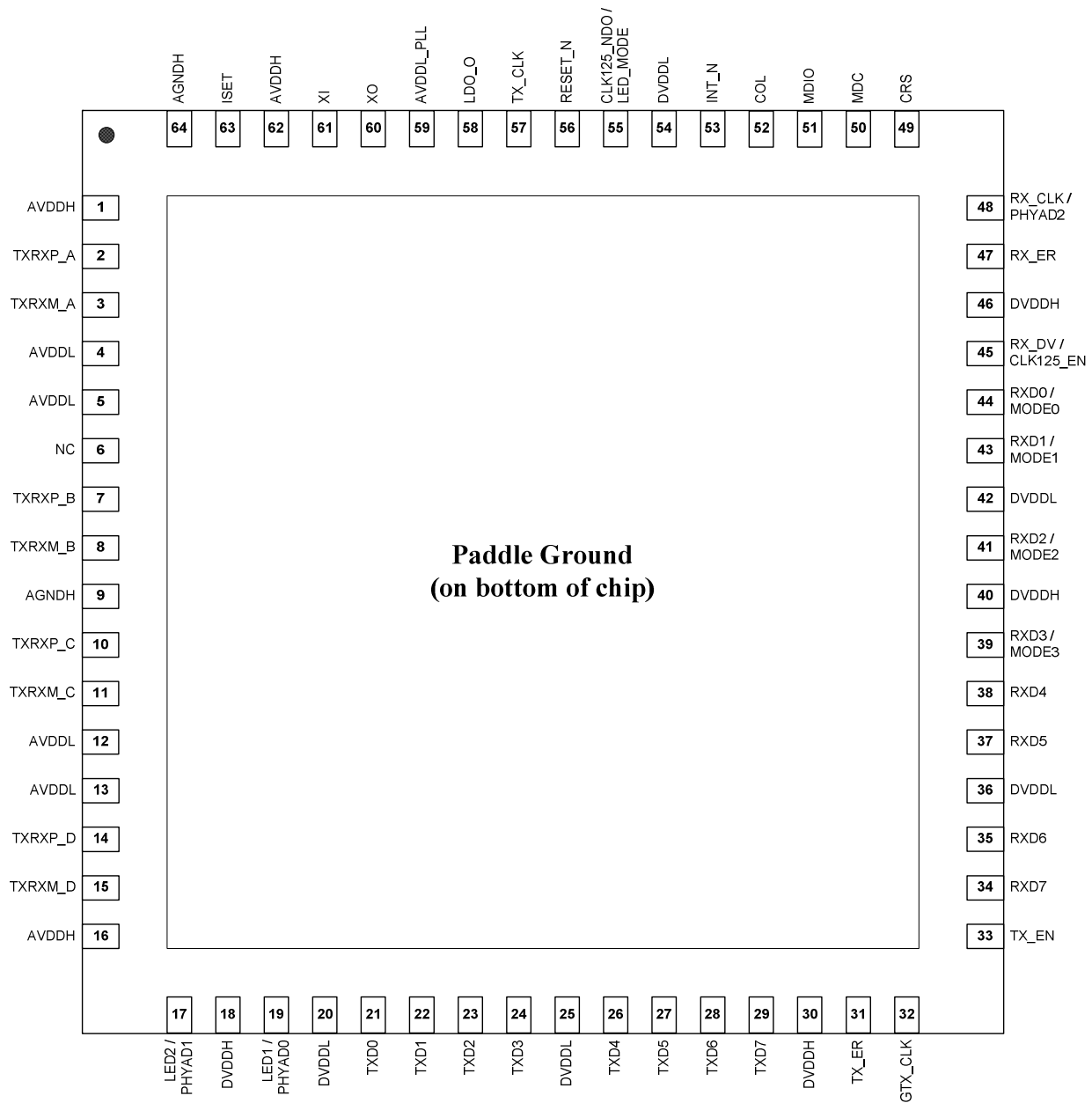

**64-Pin QFN  
(Top View)**

## Pin Description

Pin Number	Pin Name	Type <sup>(1)</sup>	Pin Function
1	AVDDH	P	3.3V analog V <sub>DD</sub>
2	TXRXP_A	I/O	Media Dependent Interface[0], positive signal of differential pair 1000Base-T Mode: TXRXP_A corresponds to BI_DA+ for MDI configuration and BI_DB+ for MDI-X configuration, respectively. 10Base-T / 100Base-TX Mode: TXRXP_A is the positive transmit signal (TX+) for MDI configuration and the positive receive signal (RX+) for MDI-X configuration, respectively.
3	TXRXM_A	I/O	Media Dependent Interface[0], negative signal of differential pair 1000Base-T Mode: TXRXM_A corresponds to BI_DA- for MDI configuration and BI_DB- for MDI-X configuration, respectively. 10Base-T / 100Base-TX Mode: TXRXM_A is the negative transmit signal (TX-) for MDI configuration and the negative receive signal (RX-) for MDI-X configuration, respectively.
4	AVDDL	P	1.2V analog V <sub>DD</sub>
5	AVDDL	P	1.2V analog V <sub>DD</sub>
6	NC	-	No connect
7	TXRXP_B	I/O	Media Dependent Interface[1], positive signal of differential pair 1000Base-T Mode: TXRXP_B corresponds to BI_DB+ for MDI configuration and BI_DA+ for MDI-X configuration, respectively. 10Base-T / 100Base-TX Mode: TXRXP_B is the positive receive signal (RX+) for MDI configuration and the positive transmit signal (TX+) for MDI-X configuration, respectively.
8	TXRXM_B	I/O	Media Dependent Interface[1], negative signal of differential pair 1000Base-T Mode: TXRXM_B corresponds to BI_DB- for MDI configuration and BI_DA- for MDI-X configuration, respectively. 10Base-T / 100Base-TX Mode: TXRXM_B is the negative receive signal (RX-) for MDI configuration and the negative transmit signal (TX-) for MDI-X configuration, respectively.
9	AGNDH	Gnd	Analog ground
10	TXRXP_C	I/O	Media Dependent Interface[2], positive signal of differential pair 1000Base-T Mode: TXRXP_C corresponds to BI_DC+ for MDI configuration and BI_DD+ for MDI-X configuration, respectively. 10Base-T / 100Base-TX Mode: TXRXP_C is not used.
11	TXRXM_C	I/O	Media Dependent Interface[2], negative signal of differential pair 1000Base-T Mode: TXRXM_C corresponds to BI_DC- for MDI configuration and BI_DD- for MDI-X configuration, respectively. 10Base-T / 100Base-TX Mode: TXRXM_C is not used.

Pin Number	Pin Name	Type <sup>(1)</sup>	Pin Function																																																					
12	AVDDL	P	1.2V analog V <sub>DD</sub>																																																					
13	AVDDL	P	1.2V analog V <sub>DD</sub>																																																					
14	TXRXP_D	I/O	Media Dependent Interface[3], positive signal of differential pair 1000Base-T Mode: TXRXP_D corresponds to BI_DD+ for MDI configuration and BI_DC+ for MDI-X configuration, respectively. 10Base-T / 100Base-TX Mode: TXRXP_D is not used.																																																					
15	TXRXM_D	I/O	Media Dependent Interface[3], negative signal of differential pair 1000Base-T Mode: TXRXM_D corresponds to BI_DD- for MDI configuration and BI_DC- for MDI-X configuration, respectively. 10Base-T / 100Base-TX Mode: TXRXM_D is not used.																																																					
16	AVDDH	P	3.3V analog V <sub>DD</sub>																																																					
17	LED2 / PHYAD1	I/O	LED Output: Programmable LED2 Output / Config Mode: The pull-up/pull-down value is latched as PHYAD[1] during power-up / reset. See "Strapping Options" section for details. The LED2 pin is programmed by the LED_MODE strapping option (pin 55, and is defined as follows.  <b>Single LED Mode</b> <table border="1"> <thead> <tr> <th>Link</th> <th>Pin State</th> <th>LED Definition</th> </tr> </thead> <tbody> <tr> <td>Link off</td> <td>H</td> <td>OFF</td> </tr> <tr> <td>Link on (any speed)</td> <td>L</td> <td>ON</td> </tr> </tbody> </table>  <b>Tri-color Dual LED Mode</b> <table border="1"> <thead> <tr> <th rowspan="2">Link / Activity</th> <th colspan="2">Pin State</th> <th colspan="2">LED Definition</th> </tr> <tr> <th>LED2</th> <th>LED1</th> <th>LED2</th> <th>LED1</th> </tr> </thead> <tbody> <tr> <td>Link off</td> <td>H</td> <td>H</td> <td>OFF</td> <td>OFF</td> </tr> <tr> <td>1000 Link / No Activity</td> <td>L</td> <td>H</td> <td>ON</td> <td>OFF</td> </tr> <tr> <td>1000 Link / Activity (RX, TX)</td> <td>Toggle</td> <td>H</td> <td>Blinking</td> <td>OFF</td> </tr> <tr> <td>100 Link / No Activity</td> <td>H</td> <td>L</td> <td>OFF</td> <td>ON</td> </tr> <tr> <td>100 Link / Activity (RX, TX)</td> <td>H</td> <td>Toggle</td> <td>OFF</td> <td>Blinking</td> </tr> <tr> <td>10 Link / No Activity</td> <td>L</td> <td>L</td> <td>ON</td> <td>ON</td> </tr> <tr> <td>10 Link / Activity (RX, TX)</td> <td>Toggle</td> <td>Toggle</td> <td>Blinking</td> <td>Blinking</td> </tr> </tbody> </table> For Tri-color Dual LED Mode, LED2 works in conjunction with LED1 (pin 19 to indicate 10 Mbps Link and Activity.	Link	Pin State	LED Definition	Link off	H	OFF	Link on (any speed)	L	ON	Link / Activity	Pin State		LED Definition		LED2	LED1	LED2	LED1	Link off	H	H	OFF	OFF	1000 Link / No Activity	L	H	ON	OFF	1000 Link / Activity (RX, TX)	Toggle	H	Blinking	OFF	100 Link / No Activity	H	L	OFF	ON	100 Link / Activity (RX, TX)	H	Toggle	OFF	Blinking	10 Link / No Activity	L	L	ON	ON	10 Link / Activity (RX, TX)	Toggle	Toggle	Blinking	Blinking
Link	Pin State	LED Definition																																																						
Link off	H	OFF																																																						
Link on (any speed)	L	ON																																																						
Link / Activity	Pin State		LED Definition																																																					
	LED2	LED1	LED2	LED1																																																				
Link off	H	H	OFF	OFF																																																				
1000 Link / No Activity	L	H	ON	OFF																																																				
1000 Link / Activity (RX, TX)	Toggle	H	Blinking	OFF																																																				
100 Link / No Activity	H	L	OFF	ON																																																				
100 Link / Activity (RX, TX)	H	Toggle	OFF	Blinking																																																				
10 Link / No Activity	L	L	ON	ON																																																				
10 Link / Activity (RX, TX)	Toggle	Toggle	Blinking	Blinking																																																				
18	DVDDH	P	3.3V or 2.5V digital V <sub>DD</sub>																																																					
19	LED1 / PHYAD0	I/O	LED Output: Programmable LED1 Output / Config Mode: The pull-up/pull-down value is latched as PHYAD[0] during power-up / reset. See "Strapping Options" section for details. The LED1 pin is programmed by the LED_MODE strapping option (pin 55, and is defined as follows.																																																					

Pin Number	Pin Name	Type <sup>(1)</sup>	Pin Function																																																					
			<p><b>Single LED Mode</b></p> <table border="1"> <thead> <tr> <th>Activity</th> <th>Pin State</th> <th>LED Definition</th> </tr> </thead> <tbody> <tr> <td>No Activity</td> <td>H</td> <td>OFF</td> </tr> <tr> <td>Activity (RX, TX)</td> <td>Toggle</td> <td>Blinking</td> </tr> </tbody> </table> <p><b>Tri-color Dual LED Mode</b></p> <table border="1"> <thead> <tr> <th rowspan="2">Link / Activity</th> <th colspan="2">Pin State</th> <th colspan="2">LED Definition</th> </tr> <tr> <th>LED2</th> <th>LED1</th> <th>LED2</th> <th>LED1</th> </tr> </thead> <tbody> <tr> <td>Link off</td> <td>H</td> <td>H</td> <td>OFF</td> <td>OFF</td> </tr> <tr> <td>1000 Link / No Activity</td> <td>L</td> <td>H</td> <td>ON</td> <td>OFF</td> </tr> <tr> <td>1000 Link / Activity (RX, TX)</td> <td>Toggle</td> <td>H</td> <td>Blinking</td> <td>OFF</td> </tr> <tr> <td>100 Link / No Activity</td> <td>H</td> <td>L</td> <td>OFF</td> <td>ON</td> </tr> <tr> <td>100 Link / Activity (RX, TX)</td> <td>H</td> <td>Toggle</td> <td>OFF</td> <td>Blinking</td> </tr> <tr> <td>10 Link / No Activity</td> <td>L</td> <td>L</td> <td>ON</td> <td>ON</td> </tr> <tr> <td>10 Link / Activity (RX, TX)</td> <td>Toggle</td> <td>Toggle</td> <td>Blinking</td> <td>Blinking</td> </tr> </tbody> </table> <p>For Tri-color Dual LED Mode, LED1 works in conjunction with LED2 (pin 17 to indicate 10 Mbps Link and Activity.</p>	Activity	Pin State	LED Definition	No Activity	H	OFF	Activity (RX, TX)	Toggle	Blinking	Link / Activity	Pin State		LED Definition		LED2	LED1	LED2	LED1	Link off	H	H	OFF	OFF	1000 Link / No Activity	L	H	ON	OFF	1000 Link / Activity (RX, TX)	Toggle	H	Blinking	OFF	100 Link / No Activity	H	L	OFF	ON	100 Link / Activity (RX, TX)	H	Toggle	OFF	Blinking	10 Link / No Activity	L	L	ON	ON	10 Link / Activity (RX, TX)	Toggle	Toggle	Blinking	Blinking
Activity	Pin State	LED Definition																																																						
No Activity	H	OFF																																																						
Activity (RX, TX)	Toggle	Blinking																																																						
Link / Activity	Pin State		LED Definition																																																					
	LED2	LED1	LED2	LED1																																																				
Link off	H	H	OFF	OFF																																																				
1000 Link / No Activity	L	H	ON	OFF																																																				
1000 Link / Activity (RX, TX)	Toggle	H	Blinking	OFF																																																				
100 Link / No Activity	H	L	OFF	ON																																																				
100 Link / Activity (RX, TX)	H	Toggle	OFF	Blinking																																																				
10 Link / No Activity	L	L	ON	ON																																																				
10 Link / Activity (RX, TX)	Toggle	Toggle	Blinking	Blinking																																																				
20	DVDDL	P	1.2V digital V <sub>DD</sub>																																																					
21	TXD0	I	GMII Mode: GMII TXD0 (Transmit Data 0) Input MII Mode: MII TXD0 (Transmit Data 0) Input																																																					
22	TXD1	I	GMII Mode: GMII TXD1 (Transmit Data 1) Input MII Mode: MII TXD1 (Transmit Data 1) Input																																																					
23	TXD2	I	GMII Mode: GMII TXD2 (Transmit Data 2) Input MII Mode: MII TXD2 (Transmit Data 2) Input																																																					
24	TXD3	I	GMII Mode: GMII TXD3 (Transmit Data 3) Input MII Mode: MII TXD3 (Transmit Data 3) Input																																																					
25	DVDDL	P	1.2V digital V <sub>DD</sub>																																																					
26	TXD4	I	GMII Mode: GMII TXD4 (Transmit Data 4) Input MII Mode: This pin is not used and can be driven high or low.																																																					
27	TXD5	I	GMII Mode: GMII TXD5 (Transmit Data 5) Input MII Mode: This pin is not used and can be driven high or low.																																																					
28	TXD6	I	GMII Mode: GMII TXD6 (Transmit Data 6) Input MII Mode: This pin is not used and can be driven high or low.																																																					
29	TXD7	I	GMII Mode: GMII TXD7 (Transmit Data 7) Input MII Mode: This pin is not used and can be driven high or low.																																																					
30	DVDDH	P	3.3V or 2.5V digital V <sub>DD</sub>																																																					
31	TX_ER	I	GMII Mode: GMII TX_ER (Transmit Error) Input MII Mode: MII TX_ER (Transmit Error) Input If GMII / MII MAC does not provide the TX_ER output signal, this pin should be tied low.																																																					
32	GTX_CLK	I	GMII Mode: GMII GTX_CLK (Transmit Reference Clock) Input																																																					

Pin Number	Pin Name	Type <sup>(1)</sup>	Pin Function
33	TX_EN	I	GMII Mode: GMII TX_EN (Transmit Enable) Input MII Mode: MII TX_EN (Transmit Enable) Input
34	RXD7	O	GMII Mode: GMII RXD7 (Receive Data 7) Output MII Mode: This pin is not used and is driven low.
35	RXD6	O	GMII Mode: GMII RXD6 (Receive Data 6) Output MII Mode: This pin is not used and is driven low.
36	DVDDL	P	1.2V digital V <sub>DD</sub>
37	RXD5	O	GMII Mode: GMII RXD5 (Receive Data 5) Output MII Mode: This pin is not used and is driven low.
38	RXD4	O	GMII Mode: GMII RXD4 (Receive Data 4) Output MII Mode: This pin is not used and is driven low.
39	RXD3 / MODE3	I/O	GMII Mode: GMII RXD3 (Receive Data 3) Output MII Mode: MII RXD3 (Receive Data 3) Output / Config Mode: The pull-up/pull-down value is latched as MODE3 during power-up / reset. See "Strapping Options" section for details.
40	DVDDH	P	3.3V or 2.5V digital V <sub>DD</sub>
41	RXD2 / MODE2	I/O	GMII Mode: GMII RXD2 (Receive Data 2) Output MII Mode: MII RXD2 (Receive Data 2) Output / Config Mode: The pull-up/pull-down value is latched as MODE2 during power-up / reset. See "Strapping Options" section for details.
42	DVDDL	P	1.2V digital V <sub>DD</sub>
43	RXD1 / MODE1	I/O	GMII Mode: GMII RXD1 (Receive Data 1) Output MII Mode: MII RXD1 (Receive Data 1) Output / Config Mode: The pull-up/pull-down value is latched as MODE1 during power-up / reset. See "Strapping Options" section for details.
44	RXD0 / MODE0	I/O	GMII Mode: GMII RXD0 (Receive Data 0) Output MII Mode: MII RXD0 (Receive Data 0) Output / Config Mode: The pull-up/pull-down value is latched as MODE0 during power-up / reset. See "Strapping Options" section for details.
45	RX_DV / CLK125_EN	I/O	GMII Mode: GMII RX_DV (Receive Data Valid) Output MII Mode: MII RX_DV (Receive Data Valid) Output / Config Mode: Latched as CLK125_NDO Output Enable during power-up / reset. See "Strapping Options" section for details.
46	DVDDH	P	3.3V or 2.5V digital V <sub>DD</sub>
47	RX_ER	O	GMII Mode: GMII RX_ER (Receive Error) Output MII Mode: MII RX_ER (Receive Error) Output
48	RX_CLK / PHYAD2	I/O	GMII Mode: GMII RX_CLK (Receive Reference Clock) Output MII Mode: MII RX_CLK (Receive Reference Clock) Output / Config Mode: The pull-up/pull-down value is latched as PHYAD[2] during power-up / reset. See "Strapping Options" section for details.
49	CRS	O	GMII Mode: GMII CRS (Carrier Sense) Output MII Mode: MII CRS (Carrier Sense) Output
50	MDC	Ipu	Management Data Clock Input This pin is the input reference clock for MDIO (pin 51)

Pin Number	Pin Name	Type <sup>(1)</sup>	Pin Function
51	MDIO	Ipu/O	Management Data Input / Output This pin is synchronous to MDC (pin 50) and requires an external pull-up resistor to DVDDH (digital V <sub>DD</sub> ) in a range from 1.0K $\Omega$ to 4.7K $\Omega$ .
52	COL	O	GMII Mode: GMII COL (Collision Detected) Output MII Mode: MII COL (Collision Detected) Output
53	INT_N	O	Interrupt Output This pin provides a programmable interrupt output and requires an external pull-up resistor to DVDDH (digital V <sub>DD</sub> ) in a range from 1.0K $\Omega$ to 4.7K $\Omega$ when active low. Register 1Bh is the Interrupt Control/Status Register for programming the interrupt conditions and reading the interrupt status. Register 1Fh bit 14 sets the interrupt output to active low (default) or active high.
54	DVDDL	P	1.2V digital V <sub>DD</sub>
55	CLK125_NDO / LED_MODE	I/O	125MHz Clock Output This pin provides a 125MHz reference clock output option for use by the MAC. / Config Mode: The pull-up/pull-down value is latched as LED_MODE during power-up / reset. See "Strapping Options" section for details.
56	RESET_N	Ipu	Chip Reset (active low) Hardware pin configurations are strapped-in at the de-assertion (rising edge) of RESET_N. See "Strapping Options" section for more details.
57	TX_CLK	O	MII Mode: MII TX_CLK (Transmit Reference Clock) Output
58	LDO_O	O	On-chip 1.2V LDO Controller Output This pin drives the input gate of a P-channel MOSFET to generate 1.2V for the chip's core voltages. If 1.2V is provided by the system and this pin is not used, it can be left floating.
59	AVDDL_PLL	P	1.2V analog V <sub>DD</sub> for PLL
60	XO	O	25MHz Crystal feedback This pin is a no connect if oscillator or external clock source is used.
61	XI	I	Crystal / Oscillator / External Clock Input 25MHz +/-50ppm tolerance
62	AVDDH	P	3.3V analog V <sub>DD</sub>
63	ISET	I/O	Set transmit output level Connect a 4.99K $\Omega$ 1% resistor to ground on this pin.
64	AGNDH	Gnd	Analog ground
PADDLE	P_GND	Gnd	Exposed Paddle on bottom of chip Connect P_GND to ground.

**Note:**

1. P = Power supply.  
Gnd = Ground.  
I = Input.  
O = Output.  
I/O = Bi-directional.  
Ipu = Input with internal pull-up.  
Ipu/O = Input with internal pull-up / Output.

## Strapping Options

Pin Number	Pin Name	Type <sup>(1)</sup>	Pin Function																																		
48 17 19	PHYAD2 PHYAD1 PHYAD0	I/O I/O I/O	<p>The PHY Address, PHYAD[2:0], is latched at power-up / reset and is configurable to any value from 1 to 7. Each PHY address bit is configured as follows:</p> <p style="padding-left: 40px;">Pull-up = 1 Pull-down = 0</p> <p>PHY Address bits [4:3] are always set to '00'.</p>																																		
39 41 43 44	MODE3 MODE2 MODE1 MODE0	I/O I/O I/O I/O	<p>The MODE[3:0] strap-in pins are latched at power-up / reset and are defined as follows:</p> <table border="1" style="width: 100%; border-collapse: collapse;"> <thead> <tr> <th>MODE[3:0]</th> <th>Mode</th> </tr> </thead> <tbody> <tr><td>0000</td><td>Reserved – not used</td></tr> <tr><td>0001</td><td>GMII / MII Mode</td></tr> <tr><td>0010</td><td>Reserved – not used</td></tr> <tr><td>0011</td><td>Reserved – not used</td></tr> <tr><td>0100</td><td>NAND Tree Mode</td></tr> <tr><td>0101</td><td>Reserved – not used</td></tr> <tr><td>0110</td><td>Reserved – not used</td></tr> <tr><td>0111</td><td>Chip Power Down Mode</td></tr> <tr><td>1000</td><td>Reserved – not used</td></tr> <tr><td>1001</td><td>Reserved – not used</td></tr> <tr><td>1010</td><td>Reserved – not used</td></tr> <tr><td>1011</td><td>Reserved – not used</td></tr> <tr><td>1100</td><td>Reserved – not used</td></tr> <tr><td>1101</td><td>Reserved – not used</td></tr> <tr><td>1110</td><td>Reserved – not used</td></tr> <tr><td>1111</td><td>Reserved – not used</td></tr> </tbody> </table>	MODE[3:0]	Mode	0000	Reserved – not used	0001	GMII / MII Mode	0010	Reserved – not used	0011	Reserved – not used	0100	NAND Tree Mode	0101	Reserved – not used	0110	Reserved – not used	0111	Chip Power Down Mode	1000	Reserved – not used	1001	Reserved – not used	1010	Reserved – not used	1011	Reserved – not used	1100	Reserved – not used	1101	Reserved – not used	1110	Reserved – not used	1111	Reserved – not used
MODE[3:0]	Mode																																				
0000	Reserved – not used																																				
0001	GMII / MII Mode																																				
0010	Reserved – not used																																				
0011	Reserved – not used																																				
0100	NAND Tree Mode																																				
0101	Reserved – not used																																				
0110	Reserved – not used																																				
0111	Chip Power Down Mode																																				
1000	Reserved – not used																																				
1001	Reserved – not used																																				
1010	Reserved – not used																																				
1011	Reserved – not used																																				
1100	Reserved – not used																																				
1101	Reserved – not used																																				
1110	Reserved – not used																																				
1111	Reserved – not used																																				
45	CLK125_EN	I/O	<p>CLK125_EN is latched at power-up / reset and is defined as follows:</p> <p style="padding-left: 40px;">Pull-up = Enable 125MHz Clock Output Pull-down = Disable 125MHz Clock Output</p> <p>Pin 55 (CLK125_NDO) provides the 125MHz reference clock output option for use by the MAC.</p>																																		
55	LED_MODE	I/O	<p>LED_MODE is latched at power-up / reset and is defined as follows:</p> <p style="padding-left: 40px;">Pull-up = Single LED Mode Pull-down = Tri-color Dual LED Mode</p>																																		

**Note:**

1. I/O = Bi-directional.

Pin strap-ins are latched during power-up or reset. In some systems, the MAC receive input pins may be driven during power-up or reset, and consequently cause the PHY strap-in pins on the GMII/MII signals to be latched to the incorrect configuration. In this case, it is recommended to add external pull-ups/pull-downs on the PHY strap-in pins to ensure the PHY is configured to the correct pin strap-in mode.

## Functional Overview

The KSZ9021GN is a completely integrated triple speed (10Base-T/100Base-TX/1000Base-T) Ethernet Physical Layer Transceiver solution for transmission and reception of data over a standard CAT-5 unshielded twisted pair (UTP) cable. Its on-chip proprietary 1000Base-T transceiver and Manchester/MLT-3 signaling-based 10Base-T/100Base-TX transceivers are all IEEE 802.3 compliant.

The KSZ9021GN reduces board cost and simplifies board layout by using on-chip termination resistors for the four differential pairs and by integrating a LDO controller to drive a low cost MOSFET to supply the 1.2V core.

On the copper media interface, the KSZ9021GN can automatically detect and correct for differential pair misplacements and polarity reversals, and correct propagation delays and re-sync timing between the four differential pairs, as specified in the IEEE 802.3 standard for 1000Base-T operation.

The KSZ9021GN provides the GMII/MII interface for connection to GMACs in Gigabit Ethernet Processors and Switches for data transfer at 10/100/1000 Mbps speed.

The following figure shows a high-level block diagram of the KSZ9021GN.

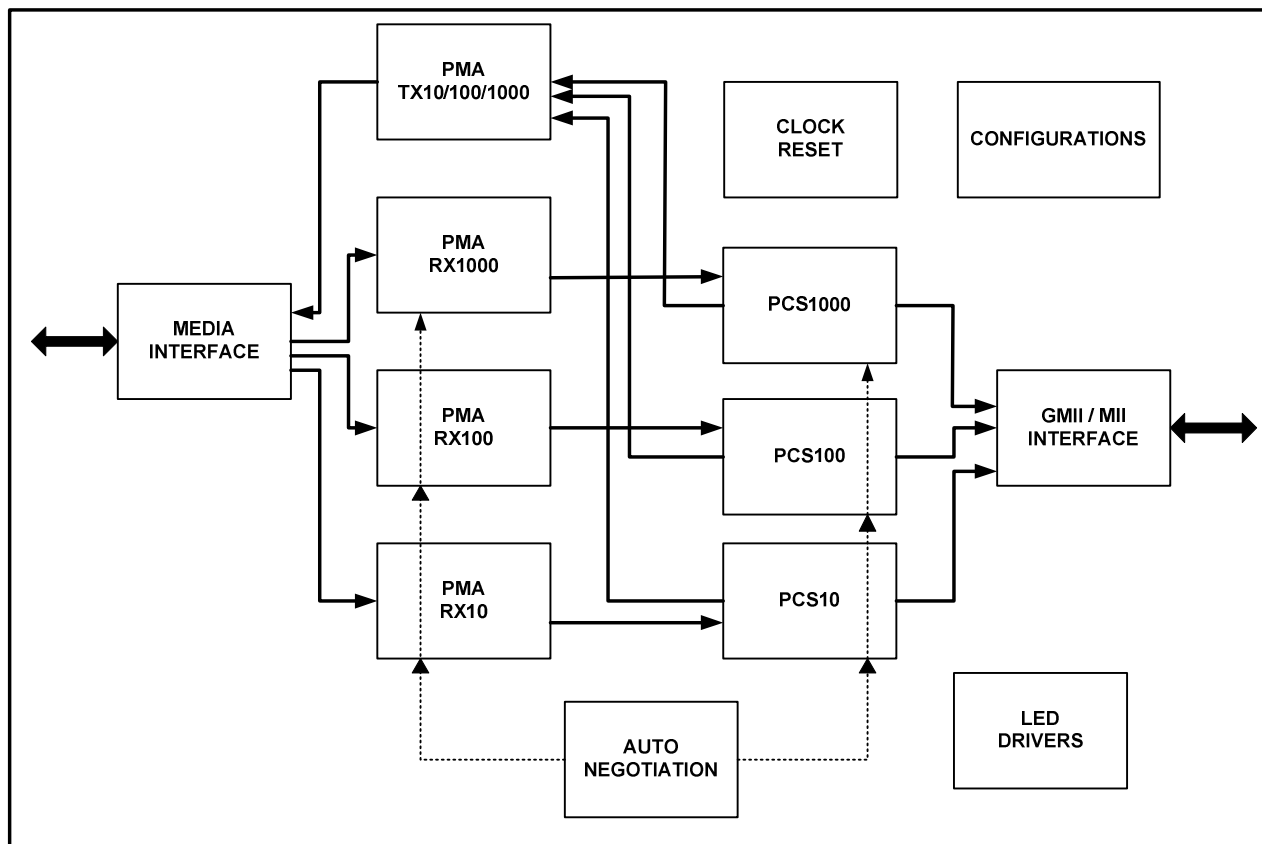

Figure 1. KSZ9021GN Block Diagram

## Functional Description: 10Base-T/100Base-TX Transceiver

### 100Base-TX Transmit

The 100Base-TX transmit function performs parallel to serial conversion, 4B/5B coding, scrambling, NRZ-to-NRZI conversion, and MLT-3 encoding and transmission.

The circuitry starts with a parallel-to-serial conversion, which converts the MII data from the MAC into a 125MHz serial bit stream. The data and control stream is then converted into 4B/5B coding, followed by a scrambler. The serialized data is further converted from NRZ-to-NRZI format, and then transmitted in MLT-3 current output. The output current is set by an external 4.99K $\Omega$  1% resistor for the 1:1 transformer ratio.

The output signal has a typical rise/fall time of 4ns and complies with the ANSI TP-PMD standard regarding amplitude balance, overshoot, and timing jitter. The wave-shaped 10Base-T output is also incorporated into the 100Base-TX transmitter.

### 100Base-TX Receive

The 100BASE-TX receiver function performs adaptive equalization, DC restoration, MLT-3-to-NRZI conversion, data and clock recovery, NRZI-to-NRZ conversion, de-scrambling, 4B/5B decoding, and serial-to-parallel conversion.

The receiving side starts with the equalization filter to compensate for inter-symbol interference (ISI) over the twisted pair cable. Since the amplitude loss and phase distortion is a function of the cable length, the equalizer must adjust its characteristics to optimize performance. In this design, the variable equalizer makes an initial estimation based on comparisons of incoming signal strength against some known cable characteristics, and then tunes itself for optimization. This is an ongoing process and self-adjusts against environmental changes such as temperature variations.

Next, the equalized signal goes through a DC restoration and data conversion block. The DC restoration circuit is used to compensate for the effect of baseline wander and to improve the dynamic range. The differential data conversion circuit converts the MLT-3 format back to NRZI. The slicing threshold is also adaptive.

The clock recovery circuit extracts the 125MHz clock from the edges of the NRZI signal. This recovered clock is then used to convert the NRZI signal into the NRZ format. This signal is sent through the de-scrambler followed by the 4B/5B decoder. Finally, the NRZ serial data is converted to the GMII/MII format and provided as the input data to the MAC.

### Scrambler/De-scrambler (100Base-TX only)

The purpose of the scrambler is to spread the power spectrum of the signal to reduce electromagnetic interference (EMI) and baseline wander. Transmitted data is scrambled through the use of an 11-bit wide linear feedback shift register (LFSR). The scrambler generates a 2047-bit non-repetitive sequence, and the receiver then de-scrambles the incoming data stream using the same sequence as at the transmitter.

### 10Base-T Transmit

The output 10Base-T driver is incorporated into the 100Base-TX driver to allow transmission with the same magnetic. They are internally wave-shaped and pre-emphasized into typical outputs of 2.5V amplitude. The harmonic contents are at least 31 dB below the fundamental when driven by an all-ones Manchester-encoded signal.

### 10Base-T Receive

On the receive side, input buffer and level detecting squelch circuits are employed. A differential input receiver circuit and a phase-locked loop (PLL) perform the decoding function. The Manchester-encoded data stream is separated into clock signal and NRZ data. A squelch circuit rejects signals with levels less than 300 mV or with short pulse widths in order to prevent noises at the receive inputs from falsely triggering the decoder. When the input exceeds the squelch limit, the PLL locks onto the incoming signal and the KSZ9021GN decodes a data frame. The receiver clock is maintained active during idle periods in between receiving data frames.



### Timing Recovery Circuit

In 1000Base-T mode, the mixed-signal clock recovery circuit together with the digital phase locked loop is used to recover and track the incoming timing information from the received data. The digital phase locked loop has very low long-term jitter to maximize the signal-to-noise ratio of the receive signal.

The 1000Base-T slave PHY is required to transmit the exact receive clock frequency recovered from the received data back to the 1000Base-T master PHY. Otherwise, the master and slave will not be synchronized after long transmission. Additionally, this helps to facilitate echo cancellation and NEXT removal.

### Adaptive Equalizer

In 1000Base-T mode, the adaptive equalizer provides the following functions:

- Detection for partial response signaling
- Removal of NEXT and ECHO noise
- Channel equalization

Signal quality is degraded by residual echo that is not removed by the analog hybrid and echo due to impedance mismatch. The KSZ9021GN employs a digital echo canceller to further reduce echo components on the receive signal.

In 1000Base-T mode, data transmission and reception occurs simultaneously on all four pairs of wires (four channels). This results in high frequency cross-talk coming from adjacent wires. The KSZ9021GN employs three NEXT cancellers on each receive channel to minimize the cross-talk induced by the other three channels.

In 10Base-T/100Base-TX mode, the adaptive equalizer needs only to remove the inter-symbol interference and recover the channel loss from the incoming data.

### Trellis Encoder and Decoder

In 1000Base-T mode, the transmitted 8-bit data is scrambled into 9-bit symbols and further encoded into 4D-PAM5 symbols. The initial scrambler seed is determined by the specific PHY address to reduce EMI when more than one KSZ9021GN are used on the same board. On the receiving side, the idle stream is examined first. The scrambler seed, pair skew, pair order and polarity have to be resolved through the logic. The incoming 4D-PAM5 data is then converted into 9-bit symbols and then de-scrambled into 8-bit data.

## Functional Description: Additional 10/100/1000 PHY Features

### Auto MDI/MDI-X

The Automatic MDI/MDI-X feature eliminates the need to determine whether to use a straight cable or a crossover cable between the KSZ9021GN and its link partner. This auto-sense function detects the MDI/MDI-X pair mapping from the link partner, and then assigns the MDI/MDI-X pair mapping of the KSZ9021GN accordingly.

The following table shows the KSZ9021GN 10/100/1000 pin-out assignments for MDI/MDI-X pin mapping.

Pin (RJ-45 pair)	MDI			MDI-X		
	1000Base-T	100Base-TX	10Base-T	1000Base-T	100Base-TX	10Base-T
TXRXP/M_A (1,2)	A+/-	TX+/-	TX+/-	B+/-	RX+/-	RX+/-
TXRXP/M_B (3,6)	B+/-	RX+/-	RX+/-	A+/-	TX+/-	TX+/-
TXRXP/M_C (4,5)	C+/-	Not used	Not used	D+/-	Not used	Not used
TXRXP/M_D (7,8)	D+/-	Not used	Not used	C+/-	Not used	Not used

**Table 1. MDI / MDI-X Pin Mapping**

Auto MDI/MDI-X is enabled by default. It is disabled by writing a one to register 28 (1Ch) bit 6. MDI and MDI-X mode is set by register 28 (1Ch) bit 7 if auto MDI/MDI-X is disabled.

An isolation transformer with symmetrical transmit and receive data paths is recommended to support auto MDI/MDI-X.

### **Pair- Swap, Alignment, and Polarity Check**

In 1000Base-T mode, the KSZ9021GN

- Detects incorrect channel order and automatically restore the pair order for the A, B, C, D pairs (four channels)
- Supports  $50\pm 10$ ns difference in propagation delay between pairs of channels in accordance with the IEEE 802.3 standard, and automatically corrects the data skew so the corrected four pairs of data symbols are synchronized

Incorrect pair polarities of the differential signals are automatically corrected for all speeds.

### **Wave Shaping, Slew Rate Control and Partial Response**

In communication systems, signal transmission encoding methods are used to provide the noise-shaping feature and to minimize distortion and error in the transmission channel.

- For 1000Base-T, a special partial response signaling method is used to provide the band-limiting feature for the transmission path.
- For 100Base-TX, a simple slew rate control method is used to minimize EMI.
- For 10Base-T, pre-emphasis is used to extend the signal quality through the cable.

### **PLL Clock Synthesizer**

The KSZ9021GN generates 125MHz, 25MHz and 10MHz clocks for system timing. Internal clocks are generated from the external 25 MHz crystal or reference clock.

### **Auto-Negotiation**

The KSZ9021GN conforms to the auto-negotiation protocol, defined in Clause 28 of the IEEE 802.3 Specification.

Auto-negotiation allows UTP (Unshielded Twisted Pair) link partners to select the highest common mode of operation.

During auto-negotiation, link partners advertise capabilities across the UTP link to each other, and then compare their own capabilities with those they received from their link partners. The highest speed and duplex setting that is common to the two link partners is selected as the mode of operation.

The following list shows the speed and duplex operation mode from highest to lowest.

- Priority 1: 1000Base-T, full-duplex
- Priority 2: 1000Base-T, half-duplex
- Priority 3: 100Base-TX, full-duplex
- Priority 4: 100Base-TX, half-duplex
- Priority 5: 10Base-T, full-duplex
- Priority 6: 10Base-T, half-duplex

If auto-negotiation is not supported or the KSZ9021GN link partner is forced to bypass auto-negotiation for 10Base-T and 100Base-TX modes, then the KSZ9021GN sets its operating mode by observing the input signal at its receiver. This is known as parallel detection, and allows the KSZ9021GN to establish link by listening for a fixed signal protocol in the absence of auto-negotiation advertisement protocol.

The auto-negotiation link up process is shown in the following flow chart.

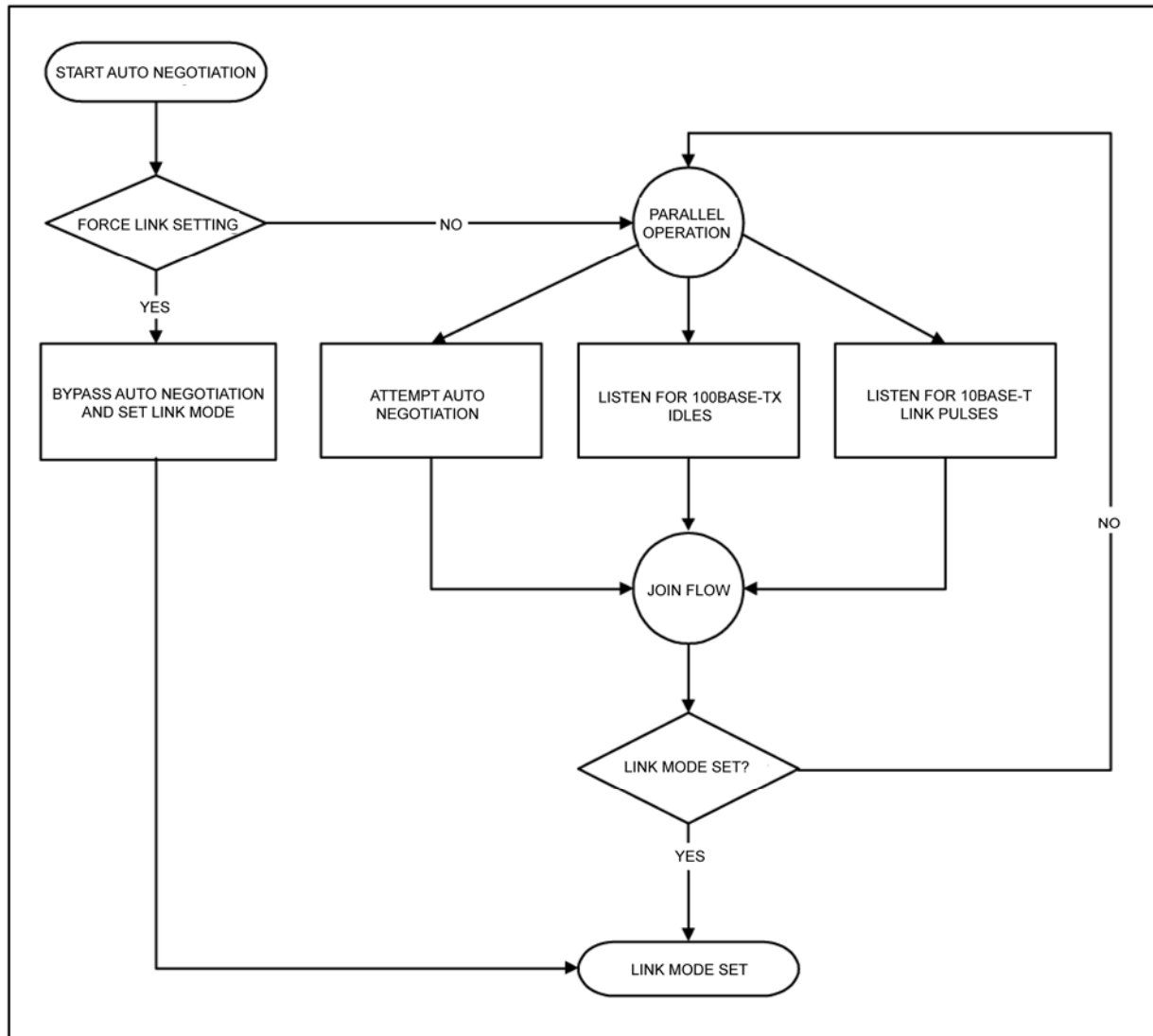

**Figure 3. Auto-Negotiation Flow Chart**

For 1000Base-T mode, auto-negotiation is required and always used to establish a link. During 1000Base-T auto-negotiation, the Master and Slave configuration is first resolved between link partners, and then the link is established with the highest common capabilities between link partners.

Auto-negotiation is enabled by default at power-up or after hardware reset. Afterwards, auto-negotiation can be enabled or disabled through register 0 bit 12. If auto-negotiation is disabled, the speed is set by register 0 bits 6 and 13, and the duplex is set by register 0 bit 8.

If the speed is changed on the fly, the link goes down and either auto-negotiation or parallel detection will initiate until a common speed between KSZ9021GN and its link partner is re-established for a link.

If link is already established and there is no change of speed on the fly, then the changes will not take effect unless either auto-negotiation is restarted through register 0 bit 9, or a link down to link up transition occurs (i.e., disconnecting and reconnecting the cable).

After auto-negotiation is completed, the link status is updated in register 1 and the link partner capabilities are updated in registers 5, 6, and 10.

The auto-negotiation finite state machines employ interval timers to manage the auto-negotiation process. The duration of these timers under normal operating conditions are summarized in the following table.

Auto-Negotiation Interval Timers	Time Duration
Transmit Burst interval	16 ms
Transmit Pulse interval	68 us
FLP detect minimum time	17.2 us
FLP detect maximum time	185 us
Receive minimum Burst interval	6.8 ms
Receive maximum Burst interval	112 ms
Data detect minimum interval	35.4 us
Data detect maximum interval	95 us
NLP test minimum interval	4.5 ms
NLP test maximum interval	30 ms
Link Loss time	52 ms
Break Link time	1480 ms
Parallel Detection wait time	830 ms
Link Enable wait time	1000 ms

**Table 2. Auto-Negotiation Timers**

## GMII Interface

The Gigabit Media Independent Interface (GMII) is compliant to the IEEE 802.3 Specification. It provides a common interface between GMII PHYs and MACs, and has the following key characteristics:

- Pin count is 24 pins (11 pins for data transmission, 11 pins for data reception, and 2 pins for carrier and collision indication).
- 1000Mbps is supported at both half and full duplex.
- Data transmission and reception are independent and belong to separate signal groups.
- Transmit data and receive data are each 8-bit wide, a byte.

In GMII operation, the GMII pins function as follow:

- The MAC sources the transmit reference clock, GTX\_CLK, at 125MHz for 1000Mbps.
- The PHY recovers and sources the receive reference clock, RX\_CLK, at 125MHz for 1000Mbps.
- TX\_EN, TXD[7:0] and TX\_ER are sampled by the KSZ9021GN on the rising edge of GTX\_CLK.
- RX\_DV, RXD[7:0], and RX\_ER are sampled by the MAC on the rising edge of RX\_CLK.
- CRS and COL are driven by the KSZ9021GN and are not required to transition synchronously with respect to either GTX\_CLK or RX\_CLK.

The KSZ9021GN combines GMII mode with MII mode to form GMII/MII mode to support data transfer at 10/100/1000 Mbps speed. After power-up or reset, the KSZ9021GN is configured to GMII/MII mode if the MODE[3:0] strap-in pins are set to 0001. See Strapping Options section.

The KSZ9021GN has the option to output a low jitter 125MHz reference clock on CLK125\_NDO (pin 55). This clock provides a lower cost reference clock alternative for GMII/MII MACs that require a 125MHz crystal or oscillator. The 125MHz clock output is enabled after power-up or reset if the CLK125\_EN strap-in pin is pulled high.

The KSZ9021GN provides a dedicated transmit clock input pin for GMII mode, defined as follow:

- GTX\_CLK (input, pin 32): Sourced by MAC in GMII mode for 1000Mbps speed

## GMII Signal Definition

The following table describes the GMII signals. Refer to Clause 35 of the IEEE 802.3 Specification for more detailed information.

GMII Signal Name (per spec)	GMII Signal Name (per KSZ9021GN)	Pin Type (with respect to PHY)	Pin Type (with respect to MAC)	Description
GTX_CLK	GTX_CLK	Input	Output	Transmit Reference Clock (125MHz for 1000Mbps)
TX_EN	TX_EN	Input	Output	Transmit Enable
TXD[7:0]	TXD[7:0]	Input	Output	Transmit Data [7:0]
TX_ER	TX_ER	Input	Output	Transmit Error
RX_CLK	RX_CLK	Output	Input	Receive Reference Clock (125MHz for 1000Mbps)
RX_DV	RX_DV	Output	Input	Receive Data Valid
RXD[7:0]	RXD[7:0]	Output	Input	Receive Data [7:0]
RX_ER	RX_ER	Output	Input	Receive Error
CRS	CRS	Output	Input	Carrier Sense
COL	COL	Output	Input	Collision Detected

**Table 3. GMII Signal Definition**

## GMII Signal Diagram

The KSZ9021GN GMII pin connections to the MAC are shown in the following figure.

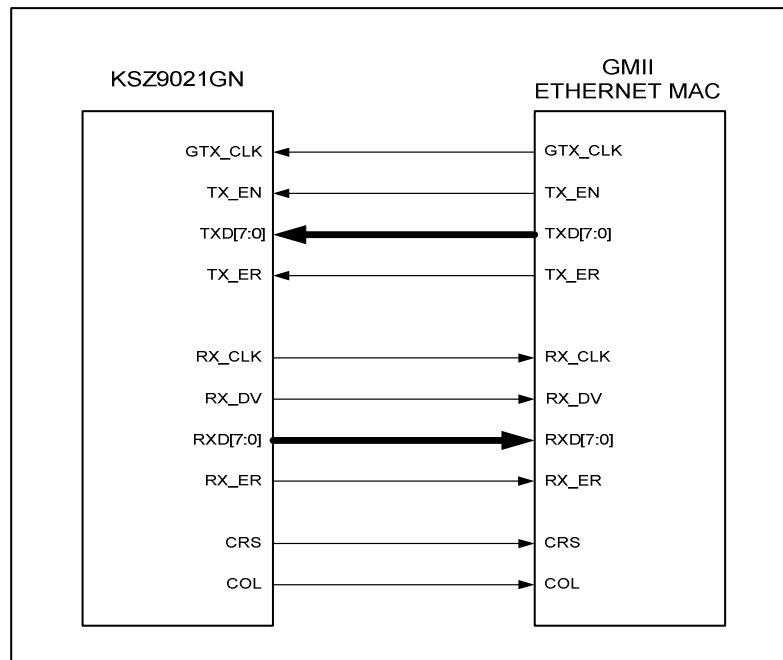

**Figure 4. KSZ9021GN GMII Interface**

## MII Interface

The Media Independent Interface (MII) is compliant with the IEEE 802.3 Specification. It provides a common interface between MII PHYs and MACs, and has the following key characteristics:

- Pin count is 16 pins (7 pins for data transmission, 7 pins for data reception, and 2 pins for carrier and collision indication).
- 10Mbps and 100Mbps are supported at both half and full duplex.
- Data transmission and reception are independent and belong to separate signal groups.
- Transmit data and receive data are each 4-bit wide, a nibble.

In MII operation, the MII pins function as follow:

- The PHY sources the transmit reference clock, TX\_CLK, at 25MHz for 100Mbps and 2.5MHz for 10Mbps.
- The PHY recovers and sources the receive reference clock, RX\_CLK, at 25MHz for 100Mbps and 2.5MHz for 10Mbps.
- TX\_EN, TXD[3:0] and TX\_ER are driven by the MAC and shall transition synchronously with respect to TX\_CLK.
- RX\_DV, RXD[3:0], and RX\_ER are driven by the KSZ9021GN and shall transition synchronously with respect to RX\_CLK.
- CRS and COL are driven by the KSZ9021GN and are not required to transition synchronously with respect to either TX\_CLK or RX\_CLK.

The KSZ9021GN combines GMII mode with MII mode to form GMII/MII mode to support data transfer at 10/100/1000 Mbps speeds. After the power-up or reset, the KSZ9021GN is then configured to GMII/MII mode if the MODE[3:0] strap-in pins are set to 0001. See Strapping Options section.

The KSZ9021GN has the option to output a low jitter 125MHz reference clock on CLK125\_NDO (pin 55). This clock provides a lower cost reference clock alternative for GMII/MII MACs that require a 125MHz crystal or oscillator. The 125MHz clock output is enabled after power-up or reset if the CLK125\_EN strap-in pin is pulled high.

The KSZ9021GN provides a dedicated transmit clock output pin for MII mode, defined as follow:

- TX\_CLK (output, pin 57): Sourced by KSZ9021GN in MII mode for 10/100Mbps speed

### MII Signal Definition

The following table describes the MII signals. Refer to Clause 22 of the IEEE 802.3 Specification for detailed information.

MII Signal Name (per spec)	MII Signal Name (per KSZ9021GN)	Pin Type (with respect to PHY)	Pin Type (with respect to MAC)	Description
TX_CLK	TX_CLK	Output	Input	Transmit Reference Clock (25MHz for 100Mbps, 2.5MHz for 10Mbps)
TX_EN	TX_EN	Input	Output	Transmit Enable
TXD[3:0]	TXD[3:0]	Input	Output	Transmit Data [3:0]
TX_ER	TX_ER	Input	Output	Transmit Error
RX_CLK	RX_CLK	Output	Input	Receive Reference Clock (25MHz for 100Mbps, 2.5MHz for 10Mbps)
RX_DV	RX_DV	Output	Input	Receive Data Valid
RXD[3:0]	RXD[3:0]	Output	Input	Receive Data [3:0]
RX_ER	RX_ER	Output	Input	Receive Error
CRS	CRS	Output	Input	Carrier Sense
COL	COL	Output	Input	Collision Detected

Table 4. MII Signal Definition

### MII Signal Diagram

The KSZ9021GN MII pin connections to the MAC are shown in the following figure.

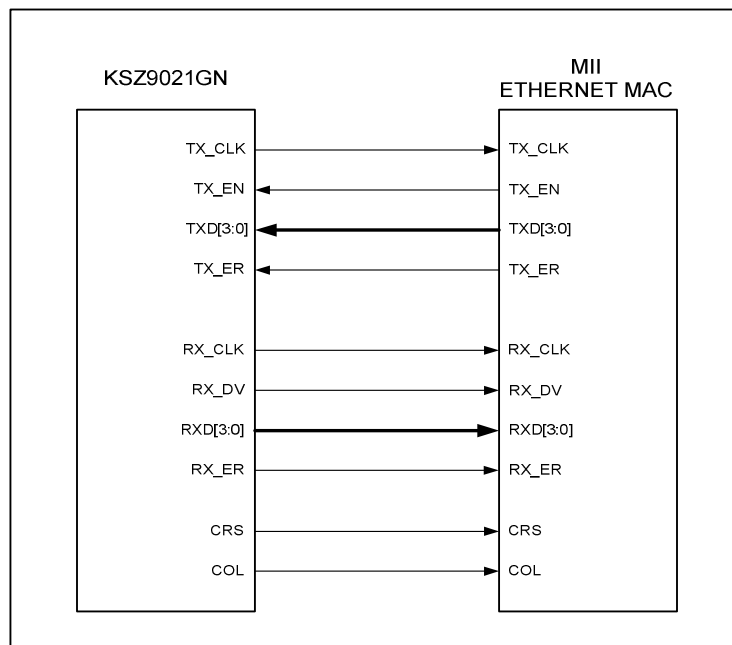

Figure 5. KSZ9021GN MII Interface

## MII Management (MIIM) Interface

The KSZ9021GN supports the IEEE 802.3 MII Management Interface, also known as the Management Data Input/Output (MDIO) Interface. This interface allows upper-layer devices to monitor and control the state of the KSZ9021GN. An external device with MIIM capability is used to read the PHY status and/or configure the PHY settings. Further detail on the MIIM interface can be found in Clause 22.2.4.5 of the IEEE 802.3 Specification.

The MIIM interface consists of the following:

- A physical connection that incorporates the clock line (MDC) and the data line (MDIO).
- A specific protocol that operates across the aforementioned physical connection that allows an external controller to communicate with one or more KSZ9021GN device. Each KSZ9021GN device is assigned a PHY address between 1 and 7 by the PHYAD[2:0] strapping pins.
- A 32 register address space to access the KSZ9021GN IEEE Defined Registers, Vendor Specific Registers and Extended Registers. See Register Map section.

The following table shows the MII Management frame format for the KSZ9021GN.

	Preamble	Start of Frame	Read/Write OP Code	PHY Address Bits [4:0]	REG Address Bits [4:0]	TA	Data Bits [15:0]	Idle
<b>Read</b>	32 1's	01	10	00AAA	RRRRR	Z0	DDDDDDDD_DDDDDDDD	Z
<b>Write</b>	32 1's	01	01	00AAA	RRRRR	10	DDDDDDDD_DDDDDDDD	Z

**Table 5. MII Management Frame Format – for KSZ9021GN**

## Interrupt (INT\_N)

INT\_N (pin 53) is an optional interrupt signal that is used to inform the external controller that there has been a status update in the KSZ9021GN PHY register. Bits [15:8] of register 27 (1Bh) are the interrupt control bits to enable and disable the conditions for asserting the INT\_N signal. Bits [7:0] of register 27 (1Bh) are the interrupt status bits to indicate which interrupt conditions have occurred. The interrupt status bits are cleared after reading register 27 (1Bh).

Bit 14 of register 31 (1Fh) sets the interrupt level to active high or active low. The default is active low.

The MII management bus option gives the MAC processor complete access to the KSZ9021GN control and status registers. Additionally, an interrupt pin eliminates the need for the processor to poll the PHY for status change.

## LED Mode

The KSZ9021GN provides two programmable LED output pins, LED2 and LED1, which are configurable to support two LED modes. The LED mode is configured by the LED\_MODE strap-in (pin 55). It is latched at power-up / reset and is defined as follows:

- Pull-up: Single LED Mode
- Pull-down: Tri-color Dual LED Mode

### Single LED Mode

In Single LED Mode, the LED2 pin indicates the link status while the LED1 pin indicates the activity status, as shown in the following table.

LED pin	Pin State	LED Definition	Link / Activity
LED2	H	OFF	Link off
	L	ON	Link on (any speed)
LED1	H	OFF	No Activity
	Toggle	Blinking	Activity (RX, TX)

**Table 6. Single LED Mode – Pin Definition**

### Tri-color Dual LED Mode

In Tri-color Dual LED Mode, the Link and Activity status are indicated by the LED2 pin for 1000Base-T, by the LED1 pin for 100Base-TX, and by both LED2 and LED1 pin, working in conjunction, for 10Base-T. This is summarized in the following table.

LED Pin (State)		LED Pin (Definition)		Link / Activity
LED2	LED1	LED2	LED1	
H	H	OFF	OFF	Link off
L	H	ON	OFF	1000 Link / No Activity
Toggle	H	Blinking	OFF	1000 Link / Activity (RX, TX)
H	L	OFF	ON	100 Link / No Activity
H	Toggle	OFF	Blinking	100 Link / Activity (RX, TX)
L	L	ON	ON	10 Link / No Activity
Toggle	Toggle	Blinking	Blinking	10 Link / Activity (RX, TX)

**Table 7. Tri-color Dual LED Mode – Pin Definition**

Each LED output pin can directly drive a LED with a series resistor (typically 220Ω to 470Ω).

For activity indication, the LED output toggles at approximately 12.5Hz (80ms) to ensure visibility to the human eye.

## NAND Tree Support

The KSZ9021GN provides parametric NAND tree support for fault detection between chip I/Os and board. The NAND tree mode is enabled at power-up / reset with the MODE[3:0] strap-in pins set to 0100.

The following table lists the NAND tree pin order.

Pin	Description
LED2	Input
LED1	Input
TXD0	Input
TXD1	Input
TXD2	Input
TXD3	Input
TX_ER	Input
GTX_CLK	Input
TX_EN	Input
RX_DV	Input
RX_ER	Input
RX_CLK	Input
CRS	Input
COL	Input
INT_N	Input
MDC	Input
MDIO	Input
CLK125_NDO	Output

**Table 8. NAND Tree Test Pin Order – for KSZ9021GN**

## Power Management

The KSZ9021GN offers the following power management modes:

### Power Saving Mode

This mode is a KSZ9021GN green feature to reduce power consumption when the cable is unplugged. It is in effect when auto-negotiation mode is enabled and the cable is disconnected (no link).

### Software Power-Down Mode

This mode is used to power down the KSZ9021GN device when it is not in use after power-up. Power-down mode is enabled by writing a one to register 0h bit 11. In the power-down state, the KSZ9021GN disables all internal functions, except for the MII management interface. The KSZ9021GN exits power-down mode after writing a zero to register 0h bit 11.

### Chip Power-Down Mode

This mode provides the lowest power state for the KSZ9021GN when it is not in use and is mounted on the board. Chip power-down mode is enabled at power-up / reset with the MODE[3:0] strap-in pins set to 0111. The KSZ9021GN exits chip power down mode when a hardware reset is applied to RESET\_N (pin 56) with the MODE[3:0] strap-in pins set to an operating mode other than chip power-down mode.

## Register Map

The IEEE 802.3 Specification provides a 32 register address space for the PHY. Registers 0 thru 15 are standard PHY registers, defined per the specification. Registers 16 thru 31 are vendor specific registers.

The KSZ9021GN uses the IEEE provided register space for IEEE Defined Registers and Vendor Specific Registers, and uses the following registers to access Extended Registers:

- Register 11 (Bh) for Extended Register – Control
- Register 12 (Ch) for Extended Register – Data Write
- Register 13 (Dh) for Extended Register – Data Read

### Examples:

- Extended Register Read // Read from Operation Mode Strap Status Register
  1. Write register 11 (Bh) with 0103h // Set register 259 (103h) for read
  2. Read register 13 (Dh) // Read register value
  
- Extended Register Write // Write to Operation Mode Strap Override Register
  1. Write register 11 (Bh) with 8102h // Set register 258 (102h) for write
  2. Write register 12 (Ch) with 0010h // Write 0010h value to register to set NAND Tree mode

Register Number (Hex)	Description
<b>IEEE Defined Registers</b>	
0 (0h)	Basic Control
1 (1h)	Basic Status
2 (2h)	PHY Identifier 1
3 (3h)	PHY Identifier 2
4 (4h)	Auto-Negotiation Advertisement
5 (5h)	Auto-Negotiation Link Partner Ability
6 (6h)	Auto-Negotiation Expansion
7 (7h)	Auto-Negotiation Next Page
8 (8h)	Auto-Negotiation Link Partner Next Page Ability
9 (9h)	1000Base-T Control
10 (Ah)	1000Base-T Status
11 (Bh)	Extended Register – Control
12 (Ch)	Extended Register – Data Write
13 (Dh)	Extended Register – Data Read
14 (Eh)	Reserved
15 (Fh)	Extended – MII Status
<b>Vendor Specific Registers</b>	
16 (10h)	Reserved
17 (11h)	Remote Loopback, LED Mode
18 (12h)	LinkMD <sup>®</sup> – Cable Diagnostic
19 (13h)	Digital PMA/PCS Status
20 (14h)	Reserved
21 (15h)	RXER Counter
22 (16h) – 26 (1Ah)	Reserved

Register Number (Hex)	Description
27 (1Bh)	Interrupt Control/Status
28 (1Ch)	Digital Debug Control 1
29 (1Dh) – 30 (1Eh)	Reserved
31 (1Fh)	PHY Control
<b>Extended Registers</b>	
257 (101h)	Strap Status
258 (102h)	Operation Mode Strap Override
259 (103h)	Operation Mode Strap Status
263 (107h)	Analog Test Register

## Register Description

### IEEE Defined Registers

Address	Name	Description	Mode <sup>(1)</sup>	Default
<b>Register 0 (0h) – Basic Control</b>				
0.15	Reset	1 = Software PHY reset 0 = Normal operation This bit is self-cleared after a '1' is written to it.	RW/SC	0
0.14	Loop-back	1 = Loop-back mode 0 = Normal operation	RW	0
0.13	Speed Select (LSB)	[0.6, 0.13] [1,1] = Reserved [1,0] = 1000Mbps [0,1] = 100Mbps [0,0] = 10Mbps This bit is ignored if auto-negotiation is enabled (register 0.12 = 1).	RW	Hardware Setting
0.12	Auto-Negotiation Enable	1 = Enable auto-negotiation process 0 = Disable auto-negotiation process If enabled, auto-negotiation result overrides settings in register 0.13, 0.8 and 0.6.	RW	1
0.11	Power Down	1 = Power down mode 0 = Normal operation	RW	0
0.10	Isolate	1 = Electrical isolation of PHY from GMII/MII 0 = Normal operation	RW	0
0.9	Restart Auto-Negotiation	1 = Restart auto-negotiation process 0 = Normal operation. This bit is self-cleared after a '1' is written to it.	RW/SC	0
0.8	Duplex Mode	1 = Full-duplex 0 = Half-duplex	RW	Hardware Setting
0.7	Collision Test	1 = Enable COL test 0 = Disable COL test	RW	0

Address	Name	Description	Mode <sup>(1)</sup>	Default
0.6	Speed Select (MSB)	[0.6, 0.13] [1,1] = Reserved [1,0] = 1000Mbps [0,1] = 100Mbps [0,0] = 10Mbps This bit is ignored if auto-negotiation is enabled (register 0.12 = 1).	RW	0
0.5:0	Reserved		RO	00_0000
<b>Register 1 (1h) – Basic Status</b>				
1.15	100Base-T4	1 = T4 capable 0 = Not T4 capable	RO	0
1.14	100Base-TX Full Duplex	1 = Capable of 100Mbps full-duplex 0 = Not capable of 100Mbps full-duplex	RO	1
1.13	100Base-TX Half Duplex	1 = Capable of 100Mbps half-duplex 0 = Not capable of 100Mbps half-duplex	RO	1
1.12	10Base-T Full Duplex	1 = Capable of 10Mbps full-duplex 0 = Not capable of 10Mbps full-duplex	RO	1
1.11	10Base-T Half Duplex	1 = Capable of 10Mbps half-duplex 0 = Not capable of 10Mbps half-duplex	RO	1
1.10:9	Reserved		RO	00
1.8	Extended Status	1 = Extended Status Information in Reg. 15. 0 = No Extended Status Information in Reg. 15.	RO	1
1.7	Reserved		RO	0
1.6	No Preamble	1 = Preamble suppression 0 = Normal preamble	RO	1
1.5	Auto-Negotiation Complete	1 = Auto-negotiation process completed 0 = Auto-negotiation process not completed	RO	0
1.4	Remote Fault	1 = Remote fault 0 = No remote fault	RO/LH	0
1.3	Auto-Negotiation Ability	1 = Capable to perform auto-negotiation 0 = Not capable to perform auto-negotiation	RO	1
1.2	Link Status	1 = Link is up 0 = Link is down	RO/LL	0
1.1	Jabber Detect	1 = Jabber detected 0 = Jabber not detected (default is low)	RO/LH	0
1.0	Extended Capability	1 = Supports extended capabilities registers	RO	1
<b>Register 2 (2h) – PHY Identifier 1</b>				
2.15:0	PHY ID Number	Assigned to the 3rd through 18th bits of the Organizationally Unique Identifier (OUI). Kendin Communication's OUI is 0010A1 (hex)	RO	0022h

Address	Name	Description	Mode <sup>(1)</sup>	Default
<b>Register 3 (3h) – PHY Identifier 2</b>				
3.15:10	PHY ID Number	Assigned to the 19th through 24 <sup>th</sup> bits of the Organizationally Unique Identifier (OUI). Kendin Communication's OUI is 0010A1 (hex)	RO	0001_01
3.9:4	Model Number	Six bit manufacturer's model number	RO	10_0001
3.3:0	Revision Number	Four bit manufacturer's revision number	RO	Indicates silicon revision
<b>Register 4 (4h) – Auto-Negotiation Advertisement</b>				
4.15	Next Page	1 = Next page capable 0 = No next page capability.	RW	0
4.14	Reserved		RO	0
4.13	Remote Fault	1 = Remote fault supported 0 = No remote fault	RW	0
4.12	Reserved		RO	0
4.11:10	Pause	[4.11, 4.10] [0,0] = No PAUSE [1,0] = Asymmetric PAUSE (link partner) [0,1] = Symmetric PAUSE [1,1] = Symmetric & Asymmetric PAUSE (local device)	RW	00
4.9	100Base-T4	1 = T4 capable 0 = No T4 capability	RO	0
4.8	100Base-TX Full-Duplex	1 = 100Mbps full-duplex capable 0 = No 100Mbps full-duplex capability	RW	1
4.7	100Base-TX Half-Duplex	1 = 100Mbps half-duplex capable 0 = No 100Mbps half-duplex capability	RW	1
4.6	10Base-T Full-Duplex	1 = 10Mbps full-duplex capable 0 = No 10Mbps full-duplex capability	RW	1
4.5	10Base-T Half-Duplex	1 = 10Mbps half-duplex capable 0 = No 10Mbps half-duplex capability	RW	1
4.4:0	Selector Field	[00001] = IEEE 802.3	RW	0_0001
<b>Register 5 (5h) – Auto-Negotiation Link Partner Ability</b>				
5.15	Next Page	1 = Next page capable 0 = No next page capability	RO	0
5.14	Acknowledge	1 = Link code word received from partner 0 = Link code word not yet received	RO	0
5.13	Remote Fault	1 = Remote fault detected 0 = No remote fault	RO	0
5.12	Reserved		RO	0

Address	Name	Description	Mode <sup>(1)</sup>	Default
5.11:10	Pause	[5.11, 5.10] [0,0] = No PAUSE [1,0] = Asymmetric PAUSE (link partner) [0,1] = Symmetric PAUSE [1,1] = Symmetric & Asymmetric PAUSE (local device)	RW	00
5.9	100Base-T4	1 = T4 capable 0 = No T4 capability	RO	0
5.8	100Base-TX Full-Duplex	1 = 100Mbps full-duplex capable 0 = No 100Mbps full-duplex capability	RO	0
5.7	100Base-TX Half-Duplex	1 = 100Mbps half-duplex capable 0 = No 100Mbps half-duplex capability	RO	0
5.6	10Base-T Full-Duplex	1 = 10Mbps full-duplex capable 0 = No 10Mbps full-duplex capability	RO	0
5.5	10Base-T Half-Duplex	1 = 10Mbps half-duplex capable 0 = No 10Mbps half-duplex capability	RO	0
5.4:0	Selector Field	[00001] = IEEE 802.3	RO	0_0000
<b>Register 6 (6h) – Auto-Negotiation Expansion</b>				
6.15:5	Reserved		RO	0000_0000_000
6.4	Parallel Detection Fault	1 = Fault detected by parallel detection 0 = No fault detected by parallel detection.	RO/LH	0
6.3	Link Partner Next Page Able	1 = Link partner has next page capability 0 = Link partner does not have next page capability	RO	0
6.2	Next Page Able	1 = Local device has next page capability 0 = Local device does not have next page capability	RO	1
6.1	Page Received	1 = New page received 0 = New page not received yet	RO/LH	0
6.0	Link Partner Auto- Negotiation Able	1 = Link partner has auto-negotiation capability 0 = Link partner does not have auto-negotiation capability	RO	0
<b>Register 7 (7h) – Auto-Negotiation Next Page</b>				
7.15	Next Page	1 = Additional next page(s) will follow 0 = Last page	RW	0
7.14	Reserved		RO	0
7.13	Message Page	1 = Message page 0 = Unformatted page	RW	1
7.12	Acknowledge2	1 = Will comply with message 0 = Cannot comply with message	RW	0
7.11	Toggle	1 = Previous value of the transmitted link code word equaled logic one 0 = Logic zero	RO	0
7.10:0	Message Field	11-bit wide field to encode 2048 messages	RW	000_0000_0001

Address	Name	Description	Mode <sup>(1)</sup>	Default
<b>Register 8 (8h) – Auto-Negotiation Link Partner Next Page Ability</b>				
8.15	Next Page	1 = Additional Next Page(s) will follow 0 = Last page	RO	0
8.14	Acknowledge	1 = Successful receipt of link word 0 = No successful receipt of link word	RO	0
8.13	Message Page	1 = Message page 0 = Unformatted page	RO	0
8.12	Acknowledge2	1 = Able to act on the information 0 = Not able to act on the information	RO	0
8.11	Toggle	1 = Previous value of transmitted link code word equal to logic zero 0 = Previous value of transmitted link code word equal to logic one	RO	0
8.10:0	Message Field		RO	000_0000_0000
<b>Register 9 (9h) – 1000Base-T Control</b>				
9:15:13	Test Mode Bits	Transmitter test mode operations [9.15:13] Mode [000] Normal Operation [001] Test mode 1 –Transmit waveform test [010] Test mode 2 –Transmit jitter test in Master mode [011] Test mode 3 –Transmit jitter test in Slave mode [100] Test mode 4 –Transmitter distortion test [101] Reserved, operations not identified [110] Reserved, operations not identified [111] Reserved, operations not identified	RW	000
9.12	MASTER-SLAVE Manual Config Enable	1 = Enable MASTER-SLAVE Manual configuration value 0 = Disable MASTER-SLAVE Manual configuration value	RW	0
9.11	MASTER-SLAVE Manual Config Value	1 = Configure PHY as MASTER during MASTER-SLAVE negotiation 0 = Configure PHY as SLAVE during MASTER-SLAVE negotiation This bit is ignored if MASTER-SLAVE Manual Config is disabled (register 9.12 = 0).	RW	0
9.10	Port Type	1 = Indicate the preference to operate as multiport device ( <b>MASTER</b> ) 0 = Indicate the preference to operate as single-port device ( <b>SLAVE</b> ) This bit is valid only if the MASTER-SLAVE Manual Config Enable bit is disabled (register 9.12 = 0).	RW	0

Address	Name	Description	Mode <sup>(1)</sup>	Default
9.9	1000Base-T Full-Duplex	1 = Advertise PHY is 1000Base-T full-duplex capable 0 = Advertise PHY is not 1000Base-T full-duplex capable	RW	1
9.8	1000Base-T Half-Duplex	1 = Advertise PHY is 1000Base-T half-duplex capable 0 = Advertise PHY is not 1000Base-T half-duplex capable	RW	Hardware Setting
9.7:0	Reserved	Write as 0, ignore on read	RO	
<b>Register 10 (Ah) – 1000Base-T Status</b>				
10.15	MASTER-SLAVE configuration fault	1 = MASTER-SLAVE configuration fault detected 0 = No MASTER-SLAVE configuration fault detected	RO/LH/SC	0
10.14	MASTER-SLAVE configuration resolution	1 = Local PHY configuration resolved to MASTER 0 = Local PHY configuration resolved to SLAVE	RO	0
10.13	Local Receiver Status	1 = Local Receiver OK (loc_rcvr_status = 1) 0 = Local Receiver not OK (loc_rcvr_status = 0)	RO	0
10.12	Remote Receiver Status	1 = Remote Receiver OK (rem_rcvr_status = 1) 0 = Remote Receiver not OK (rem_rcvr_status = 0)	RO	0
10.11	LP 1000T FD	1 = Link Partner is capable of 1000Base-T full-duplex 0 = Link Partner is not capable of 1000Base-T full-duplex	RO	0
10.10	LP 1000T HD	1 = Link Partner is capable of 1000Base-T half-duplex 0 = Link Partner is not capable of 1000Base-T half-duplex	RO	0
10.9:8	Reserved		RO	00
10.7:0	Idle Error Count	Cumulative count of errors detected when receiver is receiving idles and PMA_TXMODE.indicate = SEND_N. The counter is incremented every symbol period that rxerror_status = ERROR.	RO/SC	0000_0000
<b>Register 11 (Bh) – Extended Register – Control</b>				
11.15	Extended Register – read/write select	1 = Write Extended Register 0 = Read Extended Register	RW	0
11.14:9	Reserved		RW	000_000
11.8	Extended Register – page	Select page for Extended Register	RW	0
11.7:0	Extended Register – address	Select Extended Register Address	RW	0000_0000

Address	Name	Description	Mode <sup>(1)</sup>	Default
<b>Register 12 (Ch) – Extended Register – Data Write</b>				
12.15:0	Extended Register – write	16-bit value to write to Extend Register Address in register 11 (Bh) bits [7:0]	RW	0000_0000_0000_0000
<b>Register 13 (Dh) – Extended Register – Data Read</b>				
13.15:0	Extended Register – read	16-bit value read from Extend Register Address in register 11 (Bh) bits [7:0]	RO	0000_0000_0000_0000
<b>Register 15 (Fh) – Extended – MII Status</b>				
15.15	1000Base-X Full-duplex	1 = PHY able to perform 1000Base-X full-duplex 0 = PHY not able to perform 1000Base-X full-duplex	RO	0
15.14	1000Base-X Half-duplex	1 = PHY able to perform 1000Base-X half-duplex 0 = PHY not able to perform 1000Base-X half-duplex	RO	0
15.13	1000Base-T Full-duplex	1 = PHY able to perform 1000Base-T full-duplex 1000BASE-X 0 = PHY not able to perform 1000Base-T full-duplex	RO	1
15.12	1000Base-T Half-duplex	1 = PHY able to perform 1000Base-T half-duplex 0 = PHY not able to perform 1000Base-T half-duplex	RO	1
15.11:0	Reserved	Ignore when read	RO	-

**Note:**

1. RW = Read/Write.  
RO = Read only.  
SC = Self-cleared.  
LH = Latch high.  
LL = Latch low.

**Vendor Specific Registers**

Address	Name	Description	Mode <sup>(1)</sup>	Default
<b>Register 17 (11h) – Remote Loopback, LED Mode</b>				
17.15:9	Reserved		RW	0000_001
17.8	Remote Loopback	1 = Enable Remote Loopback 0 = Disable Remote Loopback	RW	0
17.7:6	Reserved		RW	11
17.5:4	Reserved		RW	11
17.3	LED Test Enable	1 = Enable LED test mode 0 = Disable LED test mode	RW	0

Address	Name	Description	Mode <sup>(1)</sup>	Default
17.2:1	Reserved		RW	00
17.0	Reserved		RO	0
<b>Register 18 (12h) – LinkMD® – Cable Diagnostic</b>				
18.15	Reserved		RW/SC	0
18.14:8	Reserved		RW	000_0000
18.7:0	Reserved		RO	0000_0000
<b>Register 19 (13h) – Digital PMA/PCS Status</b>				
19.15:3	Reserved		RO/LH	0000_0000_0000_0
19.2	1000Base-T Link Status	1000 Base-T Link Status 1 = Link status is OK 0 = Link status is not OK	RO	0
19.1	100Base-TX Link Status	100 Base-TX Link Status 1 = Link status is OK 0 = Link status is not OK	RO	0
19.0	Reserved		RO	0
<b>Register 21 (15h) – RXER Counter</b>				
21.15:0	RXER Counter	Receive error counter for Symbol Error frames	RO/RC	0000_0000_0000_0000
<b>Register 27 (1Bh) – Interrupt Control/Status</b>				
27.15	Jabber Interrupt Enable	1 = Enable Jabber Interrupt 0 = Disable Jabber Interrupt	RW	0
27.14	Receive Error Interrupt Enable	1 = Enable Receive Error Interrupt 0 = Disable Receive Error Interrupt	RW	0
27.13	Page Received Interrupt Enable	1 = Enable Page Received Interrupt 0 = Disable Page Received Interrupt	RW	0
27.12	Parallel Detect Fault Interrupt Enable	1 = Enable Parallel Detect Fault Interrupt 0 = Disable Parallel Detect Fault Interrupt	RW	0
27.11	Link Partner Acknowledge Interrupt Enable	1 = Enable Link Partner Acknowledge Interrupt 0 = Disable Link Partner Acknowledge Interrupt	RW	0
27.10	Link Down Interrupt Enable	1 = Enable Link Down Interrupt 0 = Disable Link Down Interrupt	RW	0
27.9	Remote Fault Interrupt Enable	1 = Enable Remote Fault Interrupt 0 = Disable Remote Fault Interrupt	RW	0
27.8	Link Up Interrupt Enable	1 = Enable Link Up Interrupt 0 = Disable Link Up Interrupt	RW	0
27.7	Jabber Interrupt	1 = Jabber occurred 0 = Jabber did not occurred	RO/RC	0
27.6	Receive Error Interrupt	1 = Receive Error occurred 0 = Receive Error did not occurred	RO/RC	0

Address	Name	Description	Mode <sup>(1)</sup>	Default
27.5	Page Receive Interrupt	1 = Page Receive occurred 0 = Page Receive did not occurred	RO/RC	0
27.4	Parallel Detect Fault Interrupt	1 = Parallel Detect Fault occurred 0 = Parallel Detect Fault did not occurred	RO/RC	0
27.3	Link Partner Acknowledge Interrupt	1 = Link Partner Acknowledge occurred 0 = Link Partner Acknowledge did not occurred	RO/RC	0
27.2	Link Down Interrupt	1 = Link Down occurred 0 = Link Down did not occurred	RO/RC	0
27.1	Remote Fault Interrupt	1 = Remote Fault occurred 0 = Remote Fault did not occurred	RO/RC	0
27.0	Link Up Interrupt	1 = Link Up occurred 0 = Link Up did not occurred	RO/RC	0
<b>Register 28 (1Ch) – Digital Debug Control 1</b>				
28.15:8	Reserved		RW	0000_0000
28.7	mdi_set	mdi_set has no function when swapoff (reg28.6) is de-asserted. 1 = When swapoff is asserted, if mdi_set is asserted, chip will operate at MDI mode. 0 = When swapoff is asserted, if mdi_set is de-asserted, chip will operate at MDI-X mode.	RW	0
28.6	swapoff	1 = Disable auto crossover function 0 = Enable auto crossover function	RW	0
28.5:1	Reserved		RW	00_000
28.0	PCS Loopback	1 = Enable 10Base-T and 100Base-TX Loopback for register 0h bit 14. 0 = normal function	RW	0
<b>Register 31 (1Fh) – PHY Control</b>				
31.15	Reserved		RW	0
31.14	Interrupt Level	1 = Interrupt pin active high 0 = Interrupt pin active low	RW	0
31.13:12	Reserved		RW	00
31.11:10	Reserved		RO/LH/RC	00
31.9	Enable Jabber	1 = Enable jabber counter 0 = Disable jabber counter	RW	1
31.8:7	Reserved		RW	00
31.6	Speed status 1000Base-T	1 = Indicate chip final speed status at 1000Base-T	RO	0
31.5	Speed status 100Base-TX	1 = Indicate chip final speed status at 100Base-TX	RO	0
31.4	Speed status 10Base-T	1 = Indicate chip final speed status at 10Base-T	RO	0

Address	Name	Description	Mode <sup>(1)</sup>	Default
31.3	Duplex status	Indicate chip duplex status 1 = Full-duplex 0 = Half-duplex	RO	0
31.2	1000Base-T Master/Slave status	1 = Indicate 1000Base-T Master mode 0 = Indicate 1000Base-T Slave mode	RO	0
31.1	Software Reset	1 = Reset chip, except all registers 0 = Disable reset	RW	0
31.0	Link Status Check Fail	1 = Fail 0 = Not Failing	RO	0

**Note:**

- RW = Read/Write.  
RC = Read-cleared  
RO = Read only.  
SC = Self-cleared.  
LH = Latch high.

**Extended Registers**

Address	Name	Description	Mode <sup>(1)</sup>	Default
<b>Register 257 (101h) – Strap Status</b>				
257.15:6	Reserved		RO	
257.5	CLK125_EN status	1 = CLK125_EN strap-in is enabled 0 = CLK125_EN strap-in is disabled	RO	
257.4:0	PHYAD[4:0] status	Strapped-in value for PHY Address	RO	
<b>Register 258 (102h) – Operation Mode Strap Override</b>				
258.15:8	Reserved		RW	
258.7	Tri-state all digital I/Os	1 = Tri-state all digital I/Os for further power saving during software power down	RW	0
258.6:5	Reserved		RW	
258.4	NAND Tree override	1 = Override strap-in for NAND Tree mode	RW	
258.3:2	Reserved		RW	
258.1	GMII / MII override	1 = Override strap-in for GMII / MII mode	RW	
258.0	Reserved		RW	
<b>Register 259 (103h) – Operation Mode Strap Status</b>				
259.15:5	Reserved		RO	
259.4	NAND Tree strap-in status	1 = Strap to NAND tree mode	RO	
259.3:2	Reserved		RO	
259.1	GMII / MII strap-in status	1 = Strap to GMII / MII mode	RO	
259.0	Reserved		RO	

Address	Name	Description	Mode <sup>(1)</sup>	Default
<b>Register 263 (107h) – Analog Test Register</b>				
263.15	LDO disable	1 = LDO controller disable 0 = LDO controller enable	RW	0
263.14:9	Reserved		RW	000_000
263.8	Low frequency oscillator mode	1 = Low frequency oscillator mode enable 0 = Low frequency oscillator mode disable Use for further power saving during software power down.	RW	0
263.7:0	Reserved		RW	0000_0000

**Note:**

1. RW = Read/Write.  
RO = Read only.

### Absolute Maximum Ratings<sup>(1)</sup>

Supply Voltage	
(DVDDL, AVDDL, AVDDL_PLL).....	-0.5V to V <sub>DD</sub> +10%
(AVDDH).....	-0.5V to V <sub>DD</sub> +10%
(DVDDH).....	-0.5V to V <sub>DD</sub> +10%
Input Voltage (all inputs) .....	-0.5V to V <sub>DD</sub> +10%
Output Voltage (all outputs) .....	-0.5V to V <sub>DD</sub> +10%
Lead Temperature (soldering, 10sec.).....	260°C
Storage Temperature (T <sub>s</sub> ) .....	-55°C to +150°C

### Operating Ratings<sup>(2)</sup>

Supply Voltage	
(DVDDL, AVDDL, AVDDL_PLL)....	+1.140V to +1.260V
(AVDDH).....	+3.135V to +3.465V
(DVDDH @ 3.3V) .....	+3.135V to +3.465V
(DVDDH @ 2.5V) .....	+2.375V to +2.625V
Ambient Temperature	
(T <sub>A</sub> Commercial: KSZ9021GN).....	0°C to +70°C
(T <sub>A</sub> Industrial: KSZ9021GNI) .....	-40°C to +85°C
Maximum Junction Temperature (T <sub>J</sub> Max) .....	125°C
Thermal Resistance (θ <sub>JA</sub> ) .....	41.54°C/W
Thermal Resistance (θ <sub>JC</sub> ) .....	19.78°C/W

### Electrical Characteristics<sup>(3)</sup>

Symbol	Parameter	Condition	Min	Typ	Max	Units
<b>Supply Current – Core / Digital I/Os</b>						
I <sub>CORE</sub>	1.2V total of: DVDDL (1.2V digital core) + AVDDL (1.2V analog core) + AVDDL_PLL (1.2V for PLL)	1000Base-T Link-up (no traffic)		522		mA
		1000Base-T Full-duplex @ 100% utilization		555		mA
		100Base-TX Link-up (no traffic)		159		mA
		100Base-TX Full-duplex @ 100% utilization		160		mA
		10Base-T Link-up (no traffic)		7		mA
		10Base-T Full-duplex @ 100% utilization		7		mA
		Power-saving Mode (cable un-plugged)		15		mA
		Software Power Down Mode (register 0.11 =1)		1.3		mA
		Chip Power Down Mode (strap-in pins MODE[3:0] = 0111)		1.2		mA
I <sub>DVDDH_2.5</sub>	2.5V for digital I/Os  (GMII / MII operating @ 2.5V)	1000Base-T Link-up (no traffic)		22		mA
		1000Base-T Full-duplex @ 100% utilization		39		mA
		100Base-TX Link-up (no traffic)		15		mA
		100Base-TX Full-duplex @ 100% utilization		19		mA
		10Base-T Link-up (no traffic)		10		mA
		10Base-T Full-duplex @ 100% utilization		11		mA
		Power-saving Mode (cable un-plugged)		14		mA
		Software Power Down Mode (register 0.11 =1)		8		mA
		Chip Power Down Mode (strap-in pins MODE[3:0] = 0111)		1		mA
I <sub>DVDDH_3.3</sub>	3.3V for digital I/Os  (GMII / MII operating @ 3.3V)	1000Base-T Link-up (no traffic)		32		mA
		1000Base-T Full-duplex @ 100% utilization		57		mA
		100Base-TX Link-up (no traffic)		19		mA
		100Base-TX Full-duplex @ 100% utilization		25		mA
		10Base-T Link-up (no traffic)		13		mA
		10Base-T Full-duplex @ 100% utilization		17		mA
		Power-saving Mode (cable un-plugged)		23		mA
		Software Power Down Mode (register 0.11 =1)		16		mA
		Chip Power Down Mode (strap-in pins MODE[3:0] = 0111)		1		mA

Symbol	Parameter	Condition	Min	Typ	Max	Units
<b>Supply Current – Transceiver</b> (equivalent to current draw through external transformer center taps for PHY transceivers with current-mode transmit drivers)						
I <sub>AVDDH</sub>	3.3V for transceiver	1000Base-T Link-up (no traffic)		74		mA
		1000Base-T Full-duplex @ 100% utilization		73		mA
		100Base-TX Link-up (no traffic)		28		mA
		100Base-TX Full-duplex @ 100% utilization		28		mA
		10Base-T Link-up (no traffic)		35		mA
		10Base-T Full-duplex @ 100% utilization		43		mA
		Power-saving Mode (cable un-plugged)		35		mA
		Software Power Down Mode (register 0.11 =1)		2		mA
		Chip Power Down Mode (strap-in pins MODE[3:0] = 0111)		1		mA
<b>CMOS Inputs</b>						
V <sub>IH</sub>	Input High Voltage	DVDDH = 3.3V	2.0			V
		DVDDH = 2.5V	1.8			V
V <sub>IL</sub>	Input Low Voltage	DVDDH = 3.3V			0.8	V
		DVDDH = 2.5V			0.7	V
I <sub>IN</sub>	Input Current	V <sub>IN</sub> = GND ~ V <sub>DDIO</sub>		-10	10	μA
<b>CMOS Outputs</b>						
V <sub>OH</sub>	Output High Voltage	DVDDH = 3.3V	2.4			V
		DVDDH = 2.5V	2.0			V
V <sub>OL</sub>	Output Low Voltage	DVDDH = 3.3V			0.4	V
		DVDDH = 2.5V			0.4	V
I <sub>oz</sub>	Output Tri-State Leakage				10	μA
<b>LED Outputs</b>						
I <sub>LED</sub>	Output Drive Current	Each LED pin (LED1, LED2)		8		mA
<b>100Base-TX Transmit (measured differentially after 1:1 transformer)</b>						
V <sub>O</sub>	Peak Differential Output Voltage	100Ω termination across differential output	0.95		1.05	V
V <sub>IMB</sub>	Output Voltage Imbalance	100Ω termination across differential output			2	%
t <sub>r</sub> , t <sub>f</sub>	Rise/Fall Time		3		5	ns
	Rise/Fall Time Imbalance		0		0.5	ns
	Duty Cycle Distortion				± 0.25	ns
	Overshoot				5	%
V <sub>SET</sub>	Reference Voltage of I <sub>SET</sub>	R(I <sub>SET</sub> ) = 4.99K		0.535		V
	Output Jitter	Peak-to-peak		0.7	1.4	ns
<b>10Base-T Transmit (measured differentially after 1:1 transformer)</b>						
V <sub>P</sub>	Peak Differential Output Voltage	100Ω termination across differential output	2.2		2.8	V
	Jitter Added	Peak-to-peak			3.5	ns
	Harmonic Rejection	Transmit all-one signal sequence		-31		dB
<b>10Base-T Receive</b>						
V <sub>SQ</sub>	Squelch Threshold	5MHz square wave	300	400		mV

**Notes:**

1. Exceeding the absolute maximum rating may damage the device. Stresses greater than the absolute maximum rating may cause permanent damage to the device. Operation of the device at these or any other conditions above those specified in the operating sections of this specification is not implied. Maximum conditions for extended periods may affect reliability.
2. The device is not guaranteed to function outside its operating rating.
3.  $T_A = 25^\circ\text{C}$ . Specification is for packaged product only.

## Timing Diagrams

### GMII Transmit Timing

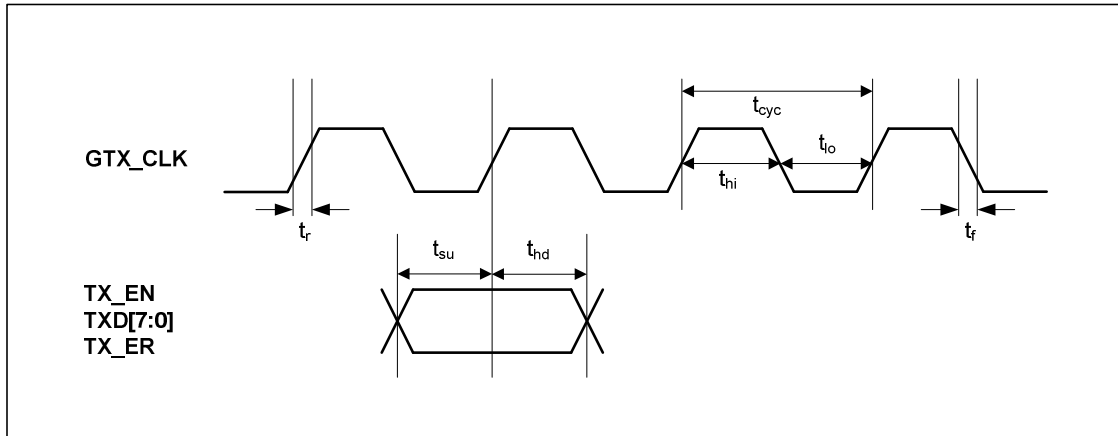
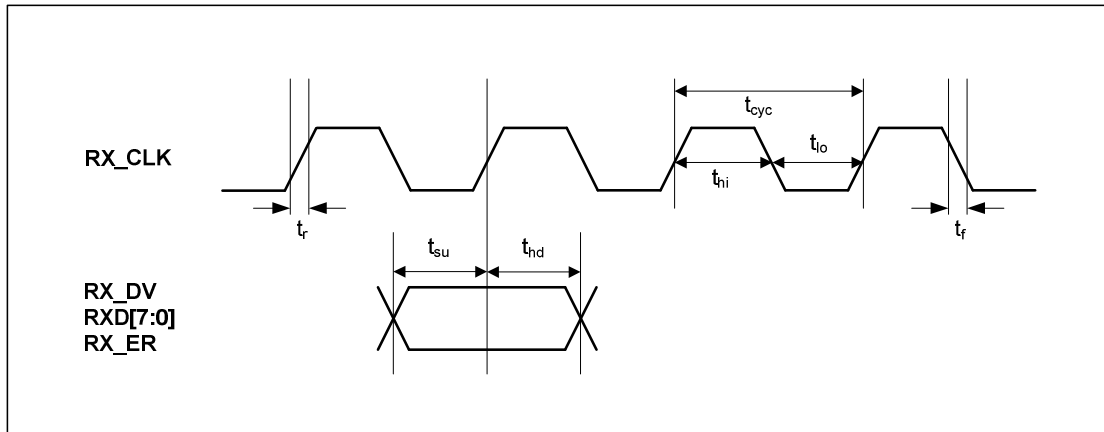

Figure 6. GMII Transmit Timing – Data Input to PHY

Timing Parameter	Description	Min	Typ	Max	Unit
<b>1000Base-T</b>					
$t_{cyc}$	GTX_CLK period	7.5	8.0	8.5	ns
$t_{su}$	TX_EN, TXD[7:0], TX_ER setup time to rising edge of GTX_CLK	2.0			ns
$t_{hd}$	TX_EN, TXD[7:0], TX_ER hold time from rising edge of GTX_CLK	0			ns
$t_{hi}$	GTX_CLK high pulse width	2.5			ns
$t_{lo}$	GTX_CLK low pulse width	2.5			ns
$t_r$	GTX_CLK rise time			1.0	ns
$t_f$	GTX_CLK fall time			1.0	ns

Table 9. GMII Transmit Timing Parameters

**GMII Receive Timing**

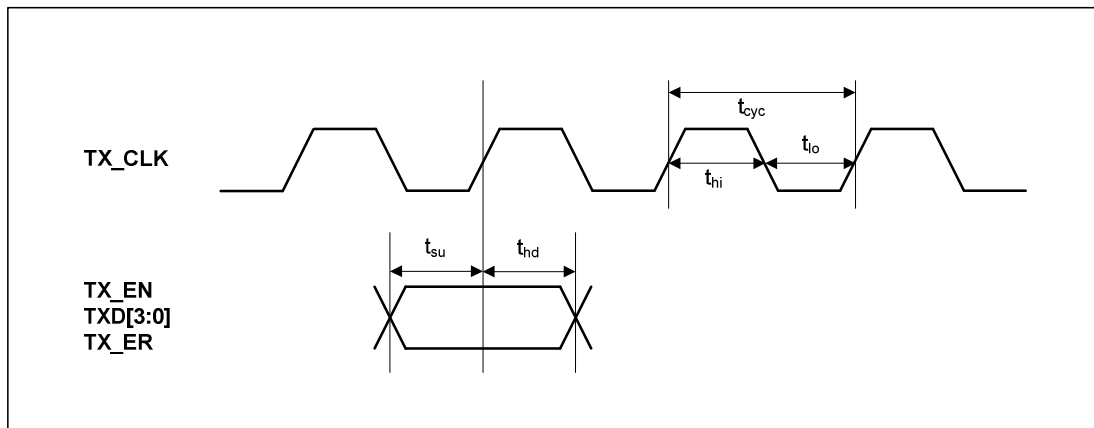

**Figure 7. GMII Receive Timing – Data Input to MAC**

Timing Parameter	Description	Min	Typ	Max	Unit
<b>1000Base-T</b>					
$t_{cyc}$	RX_CLK period	7.5	8.0	8.5	ns
$t_{su}$	RX_DV, RXD[7:0], RX_ER setup time to rising edge of RX_CLK	2.5			ns
$t_{hd}$	RX_DV, RXD[7:0], RX_ER hold time from rising edge of RX_CLK	0.5			ns
$t_{hi}$	RX_CLK high pulse width	2.5			ns
$t_{lo}$	RX_CLK low pulse width	2.5			ns
$t_r$	RX_CLK rise time			1.0	ns
$t_f$	RX_CLK fall time			1.0	ns

**Table 10. GMII Receive Timing Parameters**

**MII Transmit Timing**



**Figure 8. MII Transmit Timing – Data Input to PHY**

Timing Parameter	Description	Min	Typ	Max	Unit
<b>10Base-T</b>					
$t_{cyc}$	TX_CLK period		400		ns
$t_{su}$	TX_EN, TXD[3:0], TX_ER setup time to rising edge of TX_CLK	15			ns
$t_{hd}$	TX_EN, TXD[3:0], TX_ER hold time from rising edge of TX_CLK	0			ns
$t_{hi}$	TX_CLK high pulse width	140		260	ns
$t_{lo}$	TX_CLK low pulse width	140		260	ns
<b>100Base-TX</b>					
$t_{cyc}$	TX_CLK period		40		ns
$t_{su}$	TX_EN, TXD[3:0], TX_ER setup time to rising edge of TX_CLK	15			ns
$t_{hd}$	TX_EN, TXD[3:0], TX_ER hold time from rising edge of TX_CLK	0			ns
$t_{hi}$	TX_CLK high pulse width	14		26	ns
$t_{lo}$	TX_CLK low pulse width	14		26	ns

**Table 11. MII Transmit Timing Parameters**

MII Receive Timing

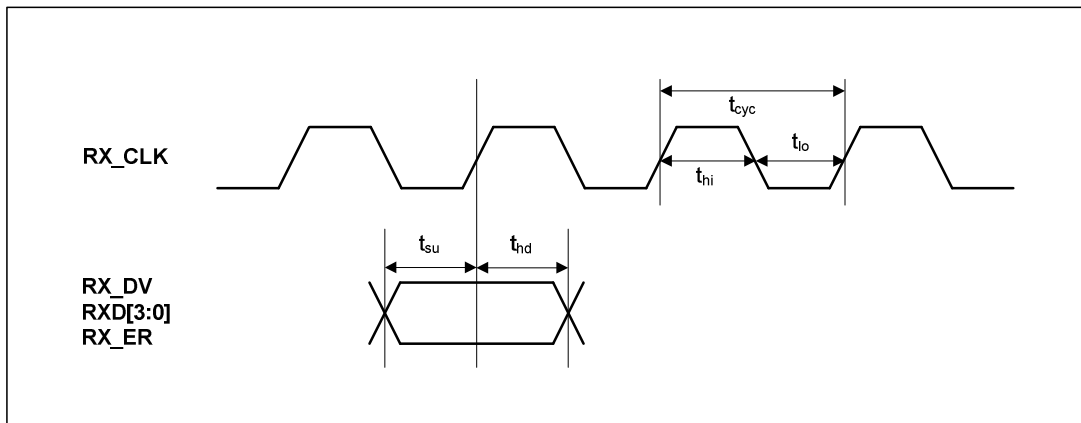
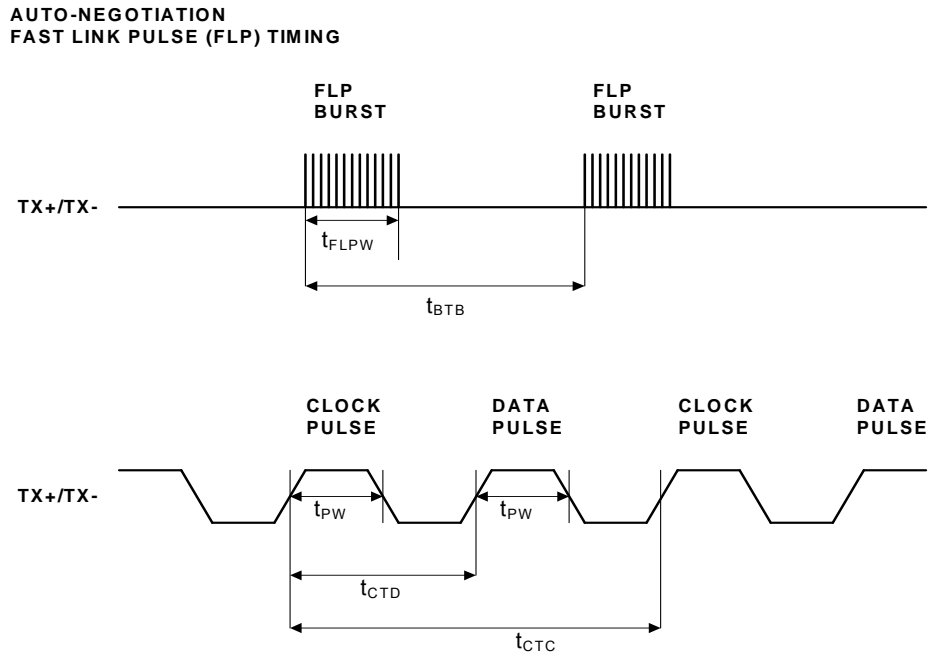

Figure 9. MII Receive Timing – Data Input to MAC

Timing Parameter	Description	Min	Typ	Max	Unit
<b>10Base-T</b>					
$t_{cyc}$	RX_CLK period		400		ns
$t_{su}$	RX_DV, RXD[3:0], RX_ER setup time to rising edge of RX_CLK	10			ns
$t_{hd}$	RX_DV, RXD[3:0], RX_ER hold time from rising edge of RX_CLK	10			ns
$t_{hi}$	RX_CLK high pulse width	140		260	ns
$t_{lo}$	RX_CLK low pulse width	140		260	ns
<b>100Base-TX</b>					
$t_{cyc}$	RX_CLK period		40		ns
$t_{su}$	RX_DV, RXD[3:0], RX_ER setup time to rising edge of RX_CLK	10			ns
$t_{hd}$	RX_DV, RXD[3:0], RX_ER hold time from rising edge of RX_CLK	10			ns
$t_{hi}$	RX_CLK high pulse width	14		26	ns
$t_{lo}$	RX_CLK low pulse width	14		26	ns

Table 12. MII Receive Timing Parameters

**Auto-Negotiation Timing**

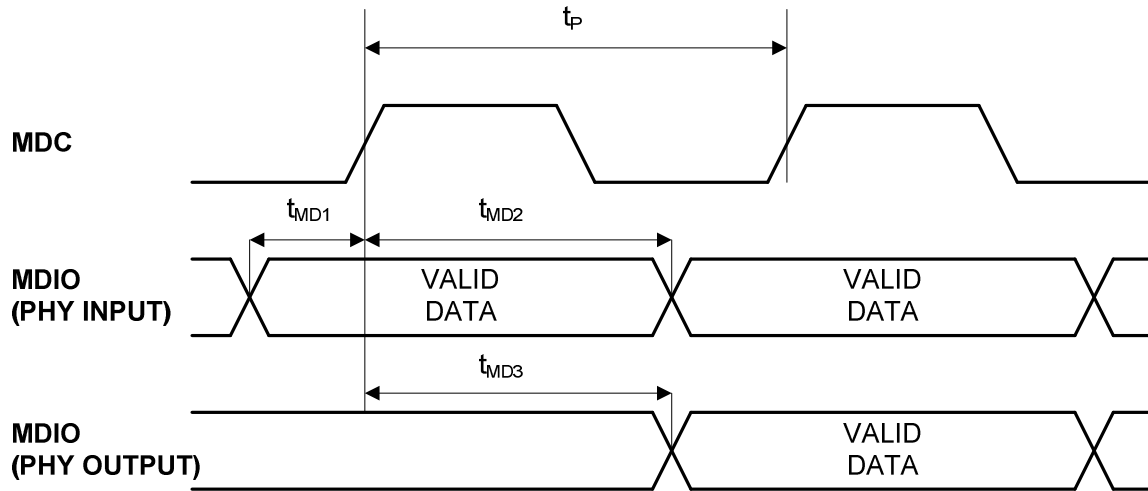

**Figure 10. Auto-Negotiation Fast Link Pulse (FLP) Timing**

Timing Parameter	Description	Min	Typ	Max	Units
$t_{BTB}$	FLP Burst to FLP Burst	8	16	24	ms
$t_{FLPW}$	FLP Burst width		2		ms
$t_{PW}$	Clock/Data Pulse width		100		ns
$t_{CTD}$	Clock Pulse to Data Pulse	55.5	64	69.5	$\mu$ s
$t_{CTC}$	Clock Pulse to Clock Pulse	111	128	139	$\mu$ s
	Number of Clock/Data Pulse per FLP Burst	17		33	

**Table 13. Auto-Negotiation Fast Link Pulse (FLP) Timing Parameters**

**MDC/MDIO Timing**



**Figure 11. MDC/MDIO Timing**

Timing Parameter	Description	Min	Typ	Max	Unit
$t_P$	MDC period		400		ns
$t_{1MD1}$	MDIO (PHY input) setup to rising edge of MDC	10			ns
$t_{MD2}$	MDIO (PHY input) hold from rising edge of MDC	10			ns
$t_{MD3}$	MDIO (PHY output) delay from rising edge of MDC	0			ns

**Table 14. MDC/MDIO Timing Parameters**

### Reset Timing

The recommended KSZ9021GN power-up reset timing is summarized in the following figure and table.

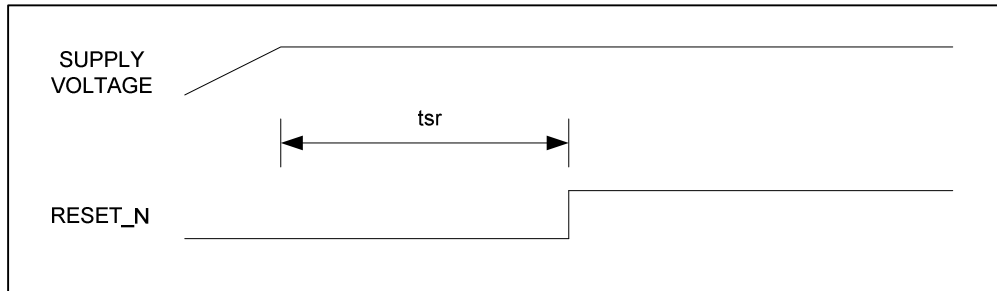

Figure 12. Reset Timing

Parameter	Description	Min	Max	Units
$t_{sr}$	Stable supply voltage to reset high	10		ms

Table 15. Reset Timing Parameters

After the de-assertion of reset, it is recommended to wait a minimum of 100 $\mu$ s before starting programming on the MIIM (MDC/MDIO) Interface.

### Reset Circuit

The following reset circuit is recommended for powering up the KSZ9021GN if reset is triggered by the power supply.

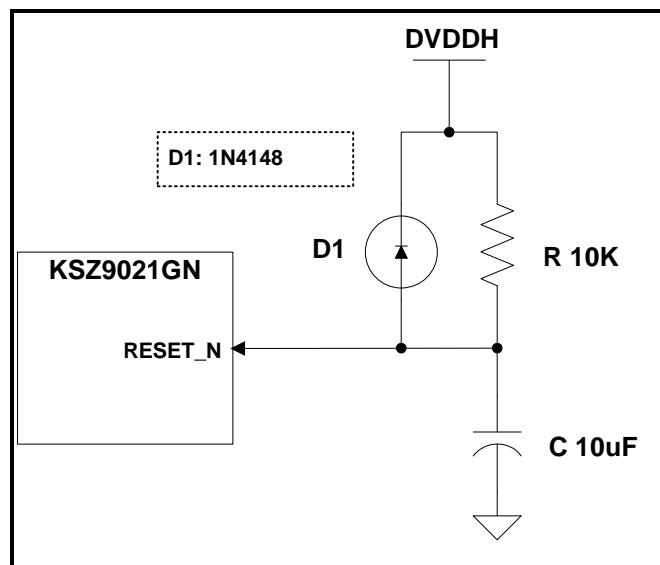

Figure 13. Recommended Reset Circuit

The following reset circuit is recommended for applications where reset is driven by another device (e.g., CPU or FPGA). At power-on-reset, R, C and D1 provide the necessary ramp rise time to reset the KSZ9021GN device. The RST\_OUT\_N from CPU/FPGA provides the warm reset after power up.

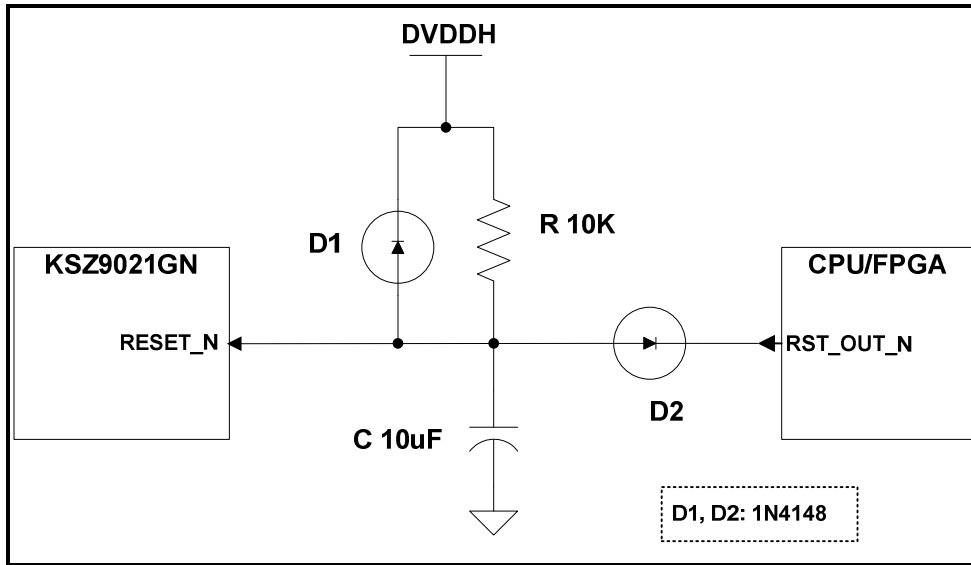

Figure 14. Recommended Reset Circuit for Interfacing with CPU/FPGA Reset Output.

### Reference Circuits – LED Strap-in Pins

The pull-up and pull-down reference circuits for the LED2/PHYAD1 and LED1/PHYAD0 strapping pins are shown in the following figure.

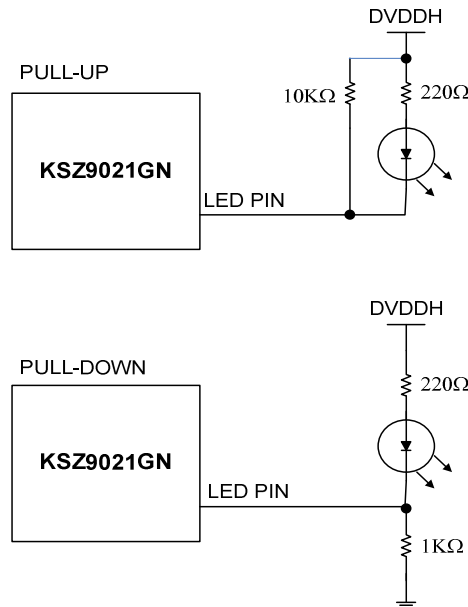

Figure 15. Reference Circuits for LED Strapping Pins

## Reference Clock – Connection and Selection

A crystal or external clock source, such as an oscillator, is used to provide the reference clock for the KSZ9021GN. The reference clock is 25 MHz for all operating modes of the KSZ9021GN.

The following figure and table shows the reference clock connection to XI (pin 61) and XO (pin 60) of the KSZ9021GN, and the reference clock selection criteria.

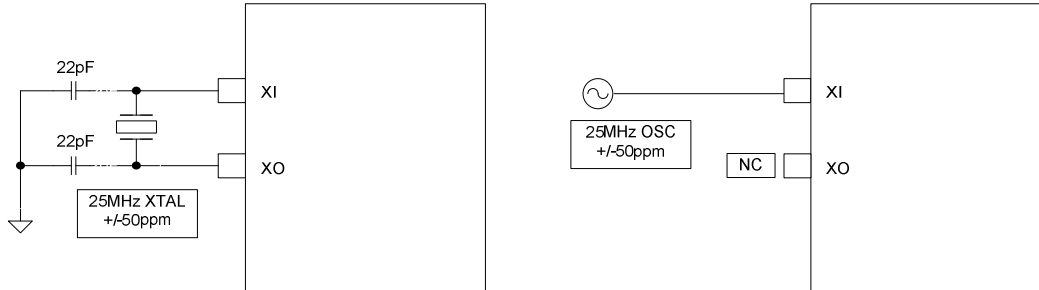

Figure 16. 25MHz Crystal / Oscillator Reference Clock Connection

Characteristics	Value	Units
Frequency	25	MHz
Frequency tolerance (max)	±50	ppm

Table 16. Reference Crystal/Clock Selection Criteria

## Magnetics Specification

A 1:1 isolation transformer is required at the line interface. An isolation transformer with integrated common-mode chokes is recommended for exceeding FCC requirements.

The following tables provide recommended magnetic characteristics and a list of qualified magnetics for the KSZ9021GN.

Parameter	Value	Test Condition
Turns ratio	1 CT : 1 CT	
Open-circuit inductance (min.)	350μH	100mV, 100kHz, 8mA
Insertion loss (max.)	1.0dB	0MHz – 100MHz
HIPOT (min.)	1500Vrms	

Table 17. Magnetics Selection Criteria

Magnetic Manufacturer	Part Number	Auto MDI-X	Number of Port
Pulse	H5007NL	Yes	1
TDK	TLA-7T101LF	Yes	1

Table 18. Qualified Single Port 10/100/1000 Magnetics

**Package Information**

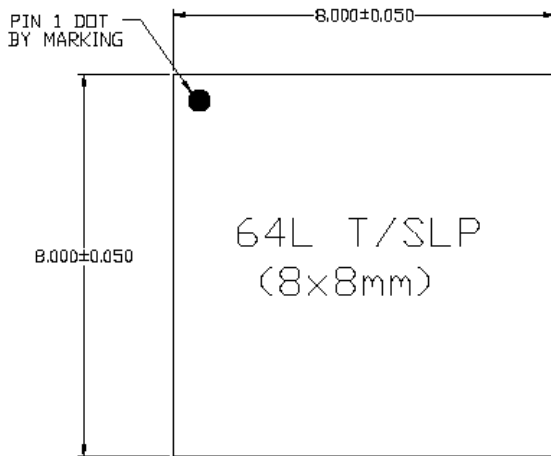

TOP VIEW

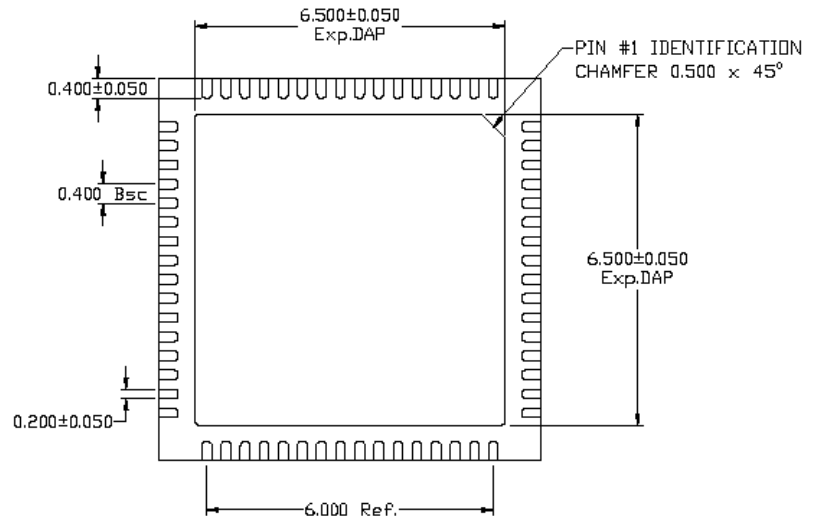

BOTTOM VIEW

**NOTE:**  
 1) TSLP AND SLP SHARE THE SAME EXPOSE OUTLINE BUT WITH DIFFERENT THICKNESS:

		TSLP	SLP
A	MAX.	0.800	0.900
	NOM.	0.750	0.850
	MIN.	0.700	0.800

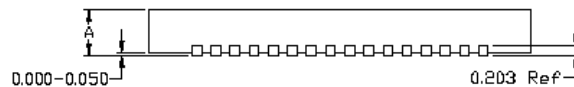

SIDE VIEW

**64-Pin (8mm x 8mm) QFN**

**MICREL, INC. 2180 FORTUNE DRIVE SAN JOSE, CA 95131 USA**

TEL +1 (408) 944-0800 FAX +1 (408) 474-1000 WEB <http://www.micrel.com>

Micrel makes no representations or warranties with respect to the accuracy or completeness of the information furnished in this data sheet. This information is not intended as a warranty and Micrel does not assume responsibility for its use. Micrel reserves the right to change circuitry, specifications and descriptions at any time without notice. No license, whether express, implied, arising by estoppel or otherwise, to any intellectual property rights is granted by this document. Except as provided in Micrel's terms and conditions of sale for such products, Micrel assumes no liability whatsoever, and Micrel disclaims any express or implied warranty relating to the sale and/or use of Micrel products including liability or warranties relating to fitness for a particular purpose, merchantability, or infringement of any patent, copyright or other intellectual property right.

Micrel Products are not designed or authorized for use as components in life support appliances, devices or systems where malfunction of a product can reasonably be expected to result in personal injury. Life support devices or systems are devices or systems that (a) are intended for surgical implant into the body or (b) support or sustain life, and whose failure to perform can be reasonably expected to result in a significant injury to the user. A Purchaser's use or sale of Micrel Products for use in life support appliances, devices or systems is a Purchaser's own risk and Purchaser agrees to fully indemnify Micrel for any damages resulting from such use or sale.

© 2009 Micrel, Incorporated.

# Mouser Electronics

Authorized Distributor

Click to View Pricing, Inventory, Delivery & Lifecycle Information:

[Microchip:](#)

[KSZ9021GN TR](#) [KSZ9021GN](#) [KSZ9021GNI](#) [KSZ9021GN-TR](#)