

Power Monitor KM-N2

Power Monitoring Functions for Control Panels in a Single Unit



- Power Monitor applicable around the globe.
- Solve design, installation, wiring, and commissioning issues with only one unit.
- Compact with a selection of several circuit measurements.



Refer to *Safety Precautions* on page 8.

For the most recent information on models that have been certified for safety standards, refer to your OMRON website.

Ordering Information

Power Monitor

Model	Applicable phase wiring methods	Power supply voltage	Dimensions	Communications
KM-N2-FLK	Single-phase, 2-wire: 100 to 277 VAC Single-phase, 3-wire: 100 to 240 VAC (L-N) or 200 to 480 VAC (L-L) Three-phase, 3-wire: 100 to 277 VAC (L-N) or 173 to 480 VAC (L-L) Three-phase, 4-wire: 100 to 277 VAC (L-N) or 173 to 480 VAC (L-L)	Same as measured circuits: 100 to 277 VAC (L-N) 173 to 480 VAC (L-L)	90 × 65 × 90 mm (W×H×D)	RS-485

KM-N2

Specifications

Ratings

Item	KM-N2-FLK
Applicable phase wiring methods	Single-phase two-wire, single-phase three-wire, three-phase three-wire, and three-phase four-wire
Maximum number of measured circuits*1	Single-phase two-wire: 4 circuits, Single-phase three-wire or three-phase three-wire: 2 circuits, Three-phase four-wire: 1 circuit
Rated input voltages (power supply voltages)	Single-phase, 2-wire: 100 to 277 VAC Single-phase, 3-wire: 100 to 240 VAC (L-N) or 200 to 480 VAC (L-L) Three-phase, 3-wire: 100 to 277 VAC (L-N) or 173 to 480 VAC (L-L) Three-phase, 4-wire: 100 to 277 VAC (L-N) or 173 to 480 VAC (L-L)
Allowable supply voltage range	85% to 115% of rated power supply voltage
Power consumption	7 VA max.
Input current (CT2 primary-side current)*2	General-purpose CT: 1 A or 5 A Rated load: 0.5 VA min.
Rated input frequency	50/60 Hz
Allowable input voltage	85% to 115% of rated power supply voltage
Allowable input current	6 A max.
Ambient operating temperature	-25 to 55°C (with no condensation or icing)
Storage temperature	-25 to 85°C (with no condensation or icing)
Ambient operating humidity	25% to 85%
Storage humidity	25% to 85%
Operating altitude	2,000 m max.
Installation environment	Overvoltage category II, pollution degree 2, measurement category II
Electromagnetic environment	Industrial electromagnetic environment (EN/IEC 61326-1 Table 2)
Compliant standards	EN 61010-2-030, EN 61326-1, and UL 61010-1

Performance

Item	KM-N2-FLK	
Measurement specifications	Active power	IEC 62053-22 class 0.5S (Accuracy $\pm 0.5\%$ F.S. ± 1 digit)*3
	Reactive power	IEC 62053-23 class 2 (Accuracy $\pm 2\%$ F.S. ± 1 digit)*3
	Sampling cycle	80 ms for 50 Hz and 66.7 ms for 60 Hz
Insulation resistance	(1) Between all electrical circuits and the case: 20 M Ω min. (at 500 VDC) (2) Between all power supply and voltage inputs and all communications and pulse output terminals: 20 M Ω max. (at 500 VDC)	
Dielectric strength	(1) Between all electrical circuits and the case: 2,200 VAC for 1 min (2) Between all voltage and current inputs and all communications and pulse output terminals: 2,200 VAC for 1 min	
Vibration resistance	Single amplitude: 0.1 mm, Acceleration: 15 m/s ² , Frequency: 10 to 150 Hz, 10 sweeps for 8 min each along three axes	
Shock resistance	150 m/s ² , 3 times each in 6 directions (up/down, left/right, forward/backward)	
Weight	Approx. 350 g (Power Monitor only)	
Degree of protection	IP20	
Pulse output	Number of outputs	Number of outputs: 4 (photoMOS relay outputs) Used for the total power consumption pulse output.
	Output capacity	50 mA at 40 VDC ON residual voltage: 1.5 V max. (for output current of 50 mA) OFF leakage current: 0.1 mA max.
	Output unit	1, 10, 100, 1k, 5k, 10k, 50k, or 100k (Wh) Pulse ON time: 500 ms (Cannot be changed.)
Commu- nications interface	Communications method	RS-485 (2-wire half-duplex with start-stop synchronization)
	Communications protocols	Modbus (RTU): Binary. CompoWay/F: ASCII
	Baud rate	1.2, 2.4, 4.8, 9.6, 19.2, or 38.4 kbps
	Data length	Data length: 7 or 8 bits Stop bits: 1 or 2 bits Vertical parity: Even, odd, or none
	Maximum transmission distance	1,200 m*3
	Maximum number of connected Power Monitors	Modbus: 99, CompoWay/F: 31
Dimensions (WxDxH)	90 × 65 × 90 mm (excluding protrusions)	
Installation method	DIN Rail mounting	
Accessories	Instruction Manual and Compliance Sheet	

*1. A CT with a different capacity can be specified for each circuit.

*2. The KM-series CTs (the KM20-CTF or KM-NCT Series) cannot be used. Use general-purpose CTs with a secondary-side output of 1 A or 5 A.

*3. The error of the CT or VT is not included. IEC 62053 is an international standard for power metering.

Part Names and Functions

Power Monitor

Front Panel with Terminal Block Covers Removed

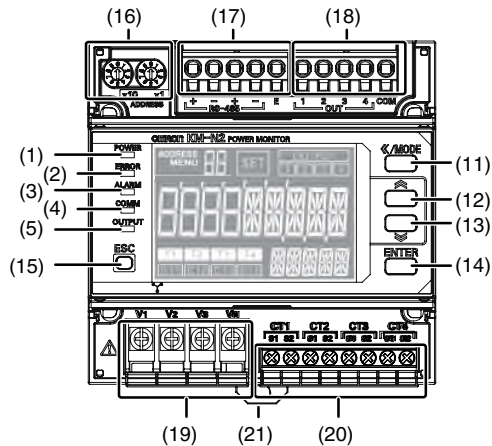

Detailed View of LCD

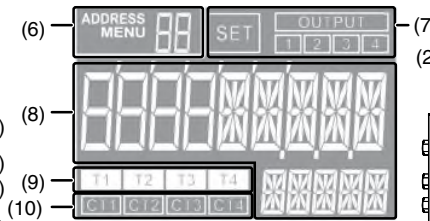

Side View

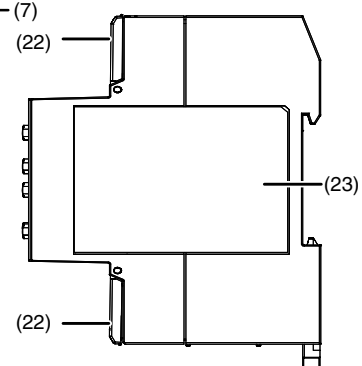

No.	Item	Description	
(1)	Power indicator (green)	Lit when the power supply is turned ON.	
(2)	Error indicator (red)	Flashes when there is an abnormality, such as a failure.	
(3)	Alarm indicator (orange)	Flashes when there is an alarm.	
(4)	Communications indicator (yellow)	Lit during communications.	
(5)	Pulse indicator (yellow)	Lit while pulses are being output from OUT1 (circuit A).	
(6)	Communications address and menu display	When ADDRESS is lit (Measurement Mode), the communications address is being displayed. When MENU is lit (Setting Mode), the menu number is being displayed.	
(7)	Status Indicators	SET	Lit in Setting Mode.
		OUTPUT	Lit while a pulse output is being set up.
		1	Lit while pulses are being output from OUT1.
		2	Lit while pulses are being output from OUT2.
		3	Lit while pulses are being output from OUT3.
(8)	Measured value/set value display	Main display	Displays the measured value or set value.
		Subdisplay	Displays the measurement unit or setting name.
(9)	Tariff display	Displays the tariff number (T1 to T4) a total active power consumption is being saved.	
(10)	CT usage display	Displays the numbers of the CTs (CT1 to CT4) for which measurement or setting operations are in progress.	
(11)	<</MODE Key	Short press: Changes the circuit or moves the digit. Long press: Changes the mode.	
(12)	▲ Key	Increments the item or value.	
(13)	▼ Key	Decrements the item or value.	
(14)	ENTER Key	Enters the item or value.	
(15)	ESC Key	Cancel	
(16)	Rotary switches	Set the communications address for circuit A. The left switch (x10) sets the tens place and the right switch (x1) sets the ones place.	
(17)	RS-485 communications terminals	RS-485 + (1)	RS-485 + terminal
		RS-485 - (1)	RS-485 - terminal
		RS-485 + (2)	RS-485 + terminal for crossover wiring
		RS-485 - (2)	RS-485 - terminal for crossover wiring
		RS-485 E	RS-485 terminating resistance terminal
(18)	Pulse output terminals	OUT1	Pulse output terminal for circuit A
		OUT2	Pulse output terminal for circuit B
		OUT3	Pulse output terminal for circuit C
		OUT4	Pulse output terminal for circuit D
		COM	Pulse output common terminal
(19)	Voltage input terminals	Terminal used to input the power supply voltage. These terminals are also used for the measured voltage inputs.	
(20)	CT input terminals	Terminals used to connect the CT cables for CT1 to CT4	
(21)	DIN hook	Hook used to mount the Power Monitor to a DIN Track	
(22)	Terminal block covers	Sealed terminal block covers	
(23)	Terminal arrangement label	Label that provides information, such as the model number, power supply voltage, terminal arrangement, and serial number	

KM-N2

Connection Wiring Diagrams

Single-phase, Two-wire Circuit

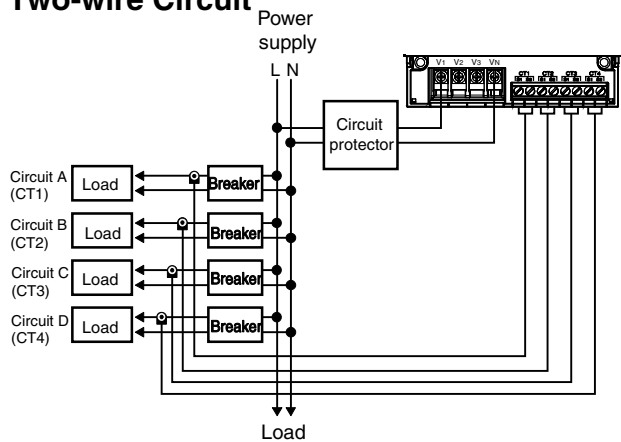

Single-phase, Two-wire Circuit with Voltage Selected

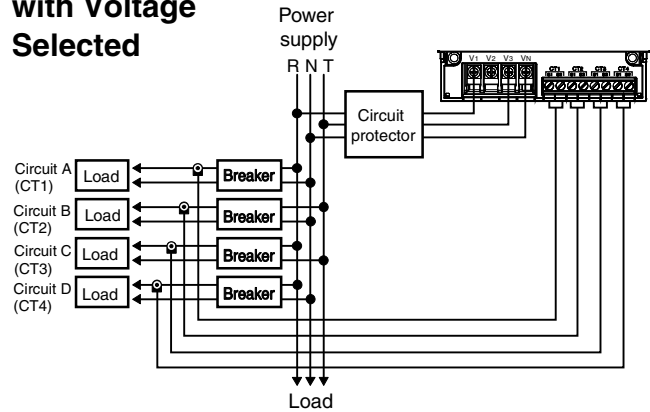

Single-phase, Three-wire Circuit

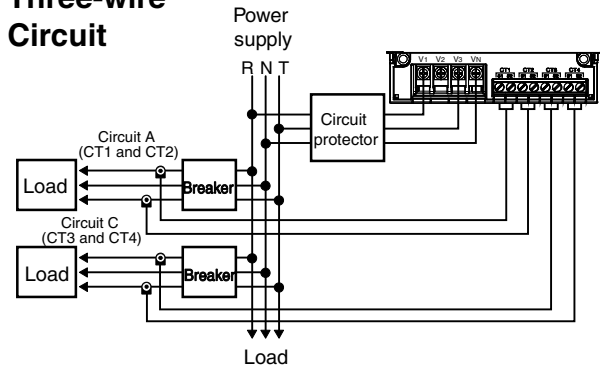

Single-phase, Three-wire Circuit with Voltage Selected

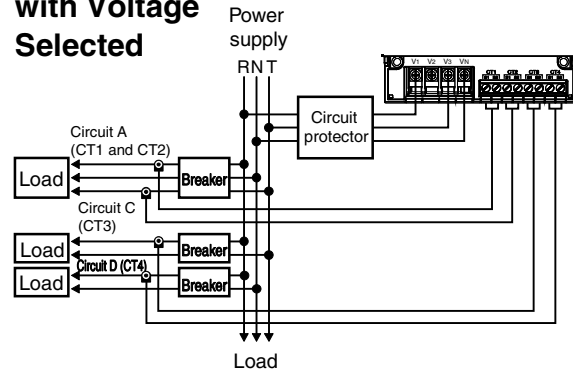

Three-phase, Three-wire Circuit

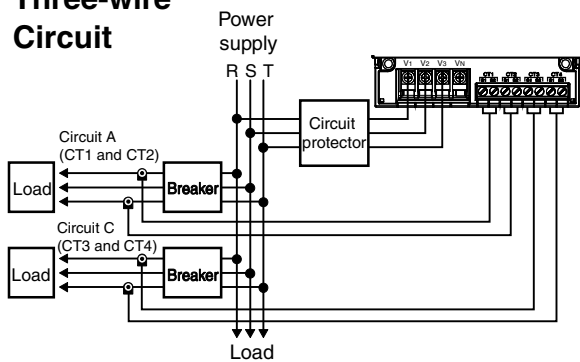

Three-phase, Four-wire Circuit

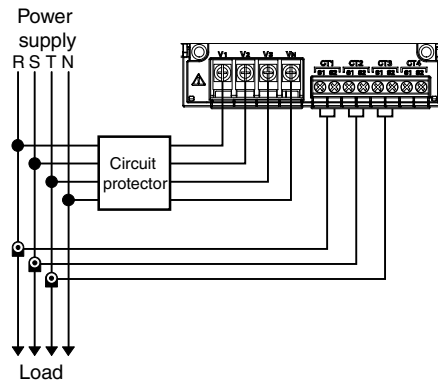

Output Stage Circuit Diagrams

Pulse Output Circuit Diagrams

NPN Output Connection Diagram

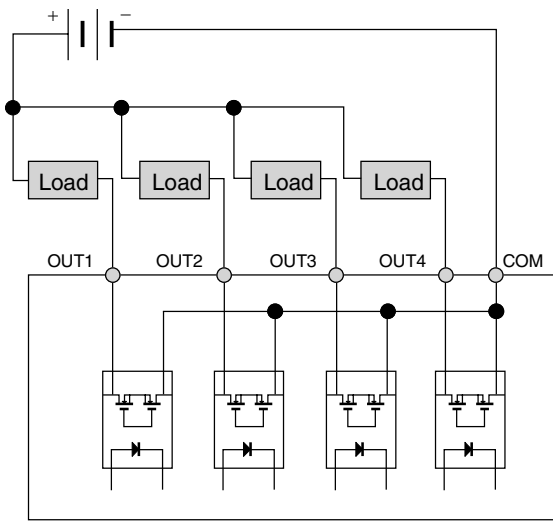

PNP Output Connection Diagram

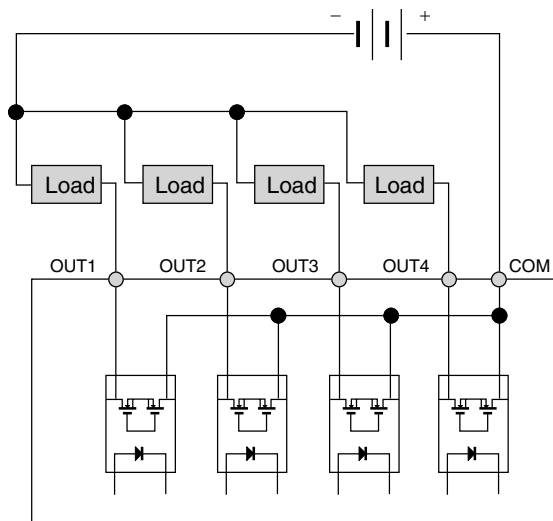

The Power Monitor provides four pulse output terminals. One common is used, terminal 5.

- The terminal block has push-in terminals. Refer also to *Push-In Plus Terminal Blocks (RS-485 Communications Terminals and Pulse Output Terminals)* on page 9 when you wire the pulse outputs.
- Never connect an external power supply directly between an output terminal and the common. Always connect a load.
- Use AWG24 to AWG14 (cross-sectional area: 0.2 to 2.0 mm²) wires to connect to the pulse output terminals.
- You can use solid wires, stranded wires, or ferrules. The recommended wire stripping length for solid wires or stranded wires is 8 to 10 mm. (However, if you use AWG14 wires, always use a stripping length of 10 mm.)
- Wire signal lines and power lines separately to prevent the influences of noise.
- The outputs are assigned as follows and cannot be changed: OUT1 is for circuit A, OUT2 is for circuit B, OUT3 is for circuit C, and OUT4 is for circuit D.

RS-485 Communications Wiring Diagram

The connection configuration is 1:1 or 1:N. For a 1:N configuration, you can connect up to 99 KM-N2 Power Monitors with Modbus and up to 31 with CompoWay/F.

- The terminal block has push-in terminals. Refer also to *Push-In Plus Terminal Blocks (RS-485 Communications Terminals and Pulse Output Terminals)* on page 9 when you wire communications.

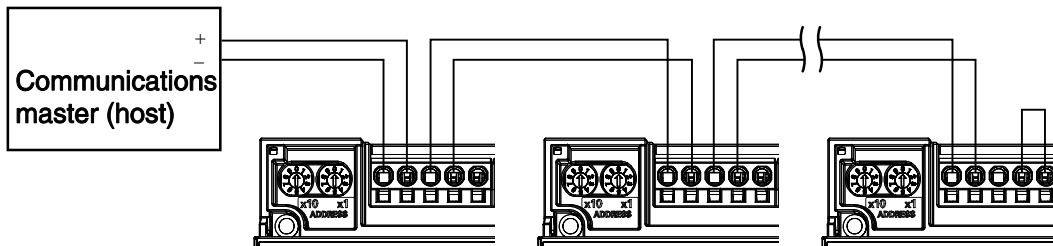

- The KM-N2 does not have a FG terminal. Connect only the positive and negative lines for RS-485.
- Use twisted-pair cables.
- Use AWG24 to AWG14 (cross-sectional area: 0.2 to 2.0 mm²) wires to connect to the RS-485 terminals.
- You can use solid wires, stranded wires, or ferrules. The recommended wire stripping length for solid wires or stranded wires is 8 to 10 mm. (However, if you use AWG14 wires, always use a stripping length of 10 mm.)
- Wire the RS-485 communications lines and power lines separately to prevent the influences of noise.
- The maximum transmission distance is 1,200 m.
- Always test communications on the actual system regardless of the transmission distances and number of connected Power Monitors.
- Always close the terminal block covers before you use the Power Monitor.

Power Supply/Voltage Input Terminals

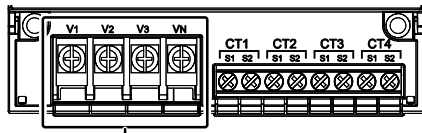

Voltage input terminals

Phase wiring method	Voltage input terminals			
	V ₁	V ₂	V ₃	V _N
Three-phase, four-wire	R	S	T	N
Single-phase, two-wire	L	-	-	N
Single-phase, three-wire	R	-	T	N
Three-phase, three-wire	R	S	T	-

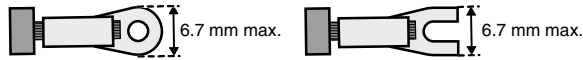

CT Terminals

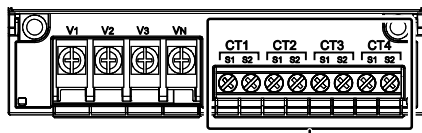

CT input terminals

Phase wiring method	Phase wiring method abbreviation	Measured circuits			
		Circuit A	Circuit B	Circuit C	Circuit D
Three-phase, four-wire	3P4W	CT1, CT2, CT3	-	-	-
Single-phase, two-wire	1P2W	CT1	CT2	CT3	CT4
Single-phase, three-wire	1P3W	CT1, CT2	-	CT3, CT4	-
Three-phase, three-wire	3P3W	CT1, CT2	-	CT3, CT4	-
Single-phase, two-wire circuit with voltage selected	1P2W2	CT1	CT2	CT3	CT4
Single-phase, two-wire composite	1P3W2	CT1, CT2	-	CT3	CT4

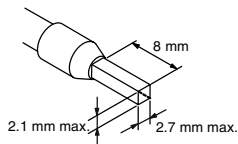

Communications Terminals and Address Setting Switches

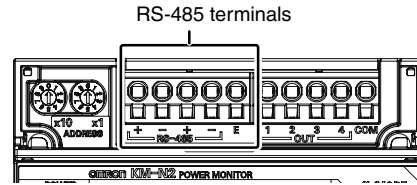

Terminal No.	Terminal name	Description
1	RS-485 +	RS-485 + terminal
2	RS-485 -	RS-485 - terminal
3	RS-485 +	RS-485 + terminal for crossover wiring
4	RS-485 -	RS-485 - terminal for crossover wiring
5	RS-485 E	RS-485 terminal resistance terminal (Terminal resistance is connected internally if this terminal is connected to terminal 4.)

Rotary switch for tens place

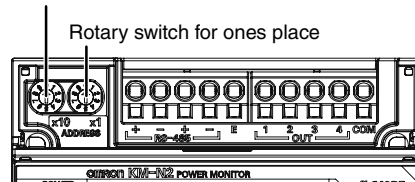

Rotary switch for ones place

Dimensions

Power Monitor

KM-N2-FLK

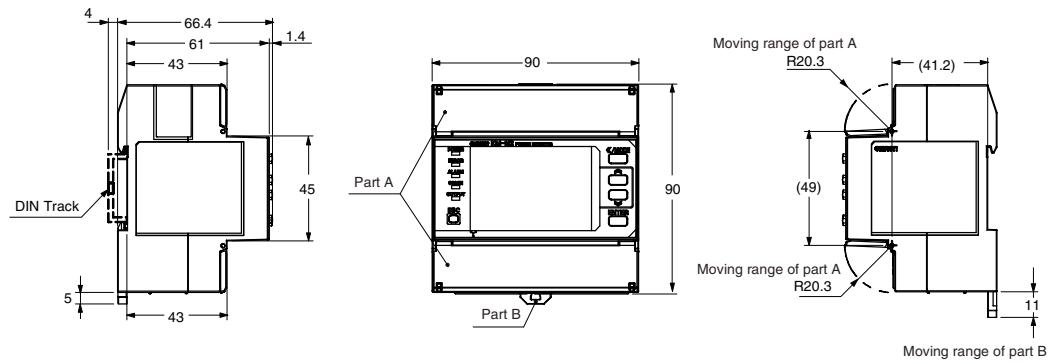





Safety Precautions

Warning Indications

 CAUTION	Indicates a potentially hazardous situation which, if not avoided, may result in minor or moderate injury or in property damage.
Precautions for Safe Use	Supplementary comments on what to do or avoid doing, to use the product safely.
Precautions for Correct Use	Supplementary comments on what to do or avoid doing, to prevent failure to operate, malfunction or undesirable effect on product performance.

Meaning of Product Safety Symbols

	Used for general mandatory action precautions for which there is no specified symbol.
	Used to warn of the risk of explosion under specific conditions.
	Used to warn of the risk of electric shock under specific conditions.
	Used for general prohibitions for which there is no specific symbol.
	Use to indicate prohibition when there is a risk of minor injury from electrical shock or other source if the product is disassembled.

Caution

Property damage may occasionally occur due to fire.
Tighten terminal screws to the specified tightening torque.
Confirm that there is no looseness in the screws after tightening them.
M3.5 screws: 0.8 N·m
M3 screws: 0.5 to 0.6 N·m



Minor or moderate bodily harm or property damage may occasionally occur due to explosion.
Do not use the Power Monitor near inflammable or explosive gas.



Destruction or rupture may occasionally occur.
Make sure that the power supply voltages and loads are within specifications and ratings.



Electrical shock may occasionally occur.
Do not touch any of the terminals while the power is being supplied.



Electric shock may occasionally occur.
Always turn OFF the power supply to the circuit where a CT is mounted before you connect the CT terminals on the Power Monitor.



Electrical shock, minor injury, fire, or equipment malfunction may occasionally occur.
Do not apply a current that exceeds the maximum current for the CT secondary side to the CT input terminals.



Electrical shock, minor injury, fire, or equipment malfunction may occasionally occur.
Do not disassemble, repair, or modify the Power Monitor.



* CT: Current transformer

Precautions for Safe Use

Observe the following precautions to ensure the safe usage of the KM-N2.

- Do not store, install, or use the Power Monitor in the following locations.
 - Locations that are greatly affected by vibration or shock
 - Unstable locations
 - Locations where the specified range of temperature or humidity would be exceeded
 - Locations that are subject to rapid changes in temperature or humidity where condensation or icing may occur
 - Outdoors or locations that are subject to direct sunlight, wind, or rain
 - Locations that are affected by static electricity or noise
 - Locations that are affected by electric or magnetic fields
 - Locations that are subject to flooding or oil
 - Locations that are subject to splashing brine
- Locations that are subject to corrosive gas (particularly sulfide or ammonia gas)**
 - Locations that are excessively dusty or dirty
 - Locations with miscible liquids
- Use AWG24 to AWG14 wires to connect the power supply and voltage input terminals.
- Use AWG18 to AWG14 wires with a heat resistance of 85°C to connect to the CT terminals.
- Use AWG24 to AWG14 wires to connect the communications terminals.
- Check all terminal numbers before wiring. Do not connect anything to unused terminals.
- Check the specifications and wiring and make sure there are no mistakes before you turn ON the power supply.
- Read and understand the Operation Manual before attempting to install, use, or maintain the Power Monitor.
- Understand the user manuals when you set the Power Monitor.**
- Do not pull on the cables.
- Install and suitably label a switch or circuit breaker that is appropriate for the voltage that is being used and complies with the relevant standards for your country so that the operator can immediately turn OFF the power supply. (USA: Use a UL-listed switch or circuit breaker, Canada: Use a cUL-listed switch or circuit breaker, Other countries: Use a switch or circuit breaker that complies with IEC 60947-1 and IEC 60947-3 or with other relevant standards.)
We recommend that you use a breaker or switch with a rated current of 0.3 to 1 A and an instantaneous tripping capacity of 10 to 14 times the rated current.
- Always check the wiring and confirm that it is correct before turning ON the power supply. Incorrect or improper wiring may result in electrical shock, injury, accidents, failure, or malfunction.
- Do not touch any of the terminals while the power is being supplied.
- Do not install the Power Monitors near sources of heat, such as devices with coils or windings.
- When you install the DIN Tracks, make sure that the screws are tightened securely. Mount the Power Monitor securely to the DIN Track. If the Power Monitor is loose, vibration or shock can cause the DIN Track, Power Monitor, or wires to become disconnected.
- Use DIN Tracks with a width of 35 mm (OMRON PFP-50N/100N).**
- If you mount the Power Monitor on DIN Track, slide the DIN hook until it securely and audibly locks in place.

- To prevent inductive noise, wire the lines connected to the Power Monitor separately from power lines carrying high voltages or currents. Do not wire in parallel with or in the same cable as power lines. Other measures for reducing noise include running lines in separate ducts and using twisted-pair cables.
- The Power Monitor is a Class A product (for use in industrial environments). In residential environment areas, it may cause radio interference. If it causes radio interference, the user may be required to take adequate measures to reduce interference.

CT Terminals

- Always use ferrules.

Recommended wire sizes	Stripping length	
	With ferrules	Without ferrules
0.8 to 2.0 mm ² (AWG18 to AWG14)	10 mm	---

Push-In Plus Terminal Blocks

- Do not wire anything to the release holes.
- Do not tilt or twist a flat-blade screwdriver while it is inserted into a release hole on the terminal block. The terminal block may be damaged.
- Insert a flat-blade screwdriver into the release holes at an angle. The terminal block may be damaged if you insert the screwdriver straight in.
- Do not allow the flat-blade screwdriver to fall out while it is inserted into a release hole.
- Do not bend a wire past its natural bending radius or pull on it with excessive force. Doing so may cause the wire disconnection.
- Do not insert more than one wire into each terminal insertion hole.
- To prevent wiring materials from smoking or ignition, use the wiring materials given in the following table.

Recommended wire gauge	Stripping length	
	Ferrules used	Ferrules not used
0.25 to 1.5mm ² /AWG24 to 16	10 mm	8 mm

Note: Please use Ferrules with UL certification (R/C).

Precautions for Correct Use

- This Power Monitor is not a Special Measuring Instrument that has passed testing by a specified body under the Measurement Act of Japan. It cannot be used to certify power consumption under Japanese law.
- Make sure that all settings are set suitably for the measurement targets.
- Mount the Power Meter to a DIN Track.
- When using the Power Monitor in an Overvoltage Category III environment, externally install varistors between the power supply and voltage measurement inputs to the Power Monitor.
- Do not use the Power Monitor for measurement on the secondary side of an inverter.
- Make sure the rated voltage is reached within 2 seconds after the power is turned ON.
- Do not use solvents, such as paint thinners, to clean the Power Monitor. Use commercially available alcohol instead.
- OMRON's KM-series CTs (e.g., the KM20-CTF or KM-NCT Series) cannot be used. Use CTs with a secondary-side output of 1 A or 5 A.
- To comply with standards, always use ferrules when you connect to the input terminals on CTs.
- The total power consumption and other data is saved every 5 minutes. When the power supply to the Power Monitor is turned OFF, the last 5 minutes worth of data may not have been saved.
- When discarding the Power Meter, properly dispose of it as industrial waste according to all applicable local ordinances.

Push-In Plus Terminal Blocks (RS-485 Communications Terminals and Pulse Output Terminals)

1. Connecting Wires to the Push-In Plus Terminal Block Part Names of the Terminal Block

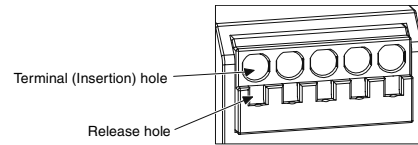

Connecting Wires with Ferrules

Insert the ferrule straight into the terminal block until the end strikes the terminal block.

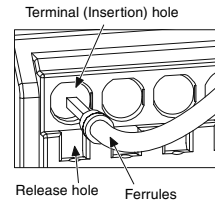

- If a wire is difficult to connect because it is too thin, use a flat-blade screwdriver in the same way as when connecting stranded wire.

Connecting Stranded Wires

Use the following procedure to connect the wires to the terminal block.

- Hold a flat-blade screwdriver at an angle and insert it into the release hole. The angle should be between 10° and 12°. If the flat-blade screwdriver is inserted correctly, you will feel the spring in the release hole.
- With the flat-blade screwdriver still inserted into the release hole, insert the wire into the terminal hole until it strikes the terminal block.
- Remove the flat-blade screwdriver from the release hole.

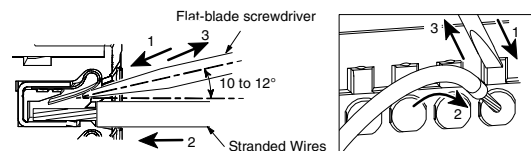

Checking Connections

- After the insertion, pull gently on the wire to make sure that it will not come off and the wire is securely fastened to the terminal block.
- To prevent short circuits, insert the stripped part of a stranded or solid wire or the conductor part of a ferrule until it is hidden inside the terminal insertion hole. (See the following diagram.)

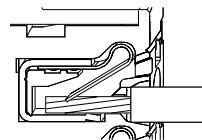

2. Removing Wires from the Push-In Plus Terminal Block

Use the following procedure to remove wires from the terminal block. The same method is used to remove stranded wires and ferrules.

1. Hold a flat-blade screwdriver at an angle and insert it into the release hole.
2. With the flat-blade screwdriver still inserted into the release hole, remove the wire from the terminal insertion hole.
3. Remove the flat-blade screwdriver from the release hole.

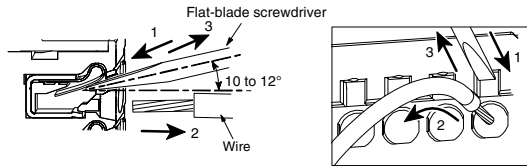

3. Recommended Ferrules and Crimp Tools

Recommended Ferrules

Applicable wire		Ferrule Conduct or length (mm)	Recommended ferrules		
(mm ²)	(AWG)		Phoenix Contact product	Weidmuller product	Wago product
0.25	24	8	AI0.25-8	H0.25/12	FE-0.25-8N-YE
0.34	22	8	AI0.34-8	H0.34/12	FE-0.34-8N-TQ
0.5	20	8	AI0.5-8	H0.5/14	FE-0.5-8N-WH
0.75	18	8	AI0.75-8	H0.75/14	FE-0.75-8N-GY
1	18	8	AI1-8	H1.0/14	FE-1.0-8N-RD
1.5	16	8	AI1.5-8	H1.5/14	FE-1.5-8N-BK
Recommended crimp tool			CRIMPFOX6 CRIMPFOX6-F CRIMPFOX10S	PZ6 roto	Variocrimp4

- *1. Make sure that the outer diameter of the wire coating is smaller than the inner diameter of the insulation sleeve of the recommended ferrule.
- *2. Make sure that the ferrule processing dimensions conform to the following figures.

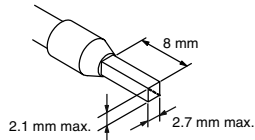

Recommended Flat-blade Screwdriver

Use a flat-blade screwdriver to connect and remove wires.

Use the following flat-blade screwdriver.

The following table shows manufacturers and models as of 2015/Dec.

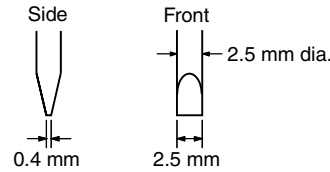

Model	Manufacturer
XW4Z-00B	Omron
ESD0.40X2.5	Wera
SZF 0.4X2.5	Phoenix Contact
0.4X2.5X75 302	Wiha
AEF.2.5X75	Facom
210-719	Wago
SDI 0.4X2.5X75	Weidmuller

Terms and Conditions of Sale

1. **Offer; Acceptance.** These terms and conditions (these "**Terms**") are deemed part of all quotes, agreements, purchase orders, acknowledgments, price lists, catalogs, manuals, brochures and other documents, whether electronic or in writing, relating to the sale of products or services (collectively, the "**Products**") by Omron Electronics LLC and its subsidiary companies ("**Omron**"). Omron objects to any terms or conditions proposed in Buyer's purchase order or other documents which are inconsistent with, or in addition to, these Terms.
2. **Prices; Payment Terms.** All prices stated are current, subject to change without notice by Omron. Omron reserves the right to increase or decrease prices on any unshipped portions of outstanding orders. Payments for Products are due net 30 days unless otherwise stated in the invoice.
3. **Discounts.** Cash discounts, if any, will apply only on the net amount of invoices sent to Buyer after deducting transportation charges, taxes and duties, and will be allowed only if (i) the invoice is paid according to Omron's payment terms and (ii) Buyer has no past due amounts.
4. **Interest.** Omron, at its option, may charge Buyer 1-1/2% interest per month or the maximum legal rate, whichever is less, on any balance not paid within the stated terms.
5. **Orders.** Omron will accept no order less than \$200 net billing.
6. **Governmental Approvals.** Buyer shall be responsible for, and shall bear all costs involved in, obtaining any government approvals required for the importation or sale of the Products.
7. **Taxes.** All taxes, duties and other governmental charges (other than general real property and income taxes), including any interest or penalties thereon, imposed directly or indirectly on Omron or required to be collected directly or indirectly by Omron for the manufacture, production, sale, delivery, importation, consumption or use of the Products sold hereunder (including customs duties and sales, excise, use, turnover and license taxes) shall be charged to and remitted by Buyer to Omron.
8. **Financial.** If the financial position of Buyer at any time becomes unsatisfactory to Omron, Omron reserves the right to stop shipments or require satisfactory security or payment in advance. If Buyer fails to make payment or otherwise comply with these Terms or any related agreement, Omron may (without liability and in addition to other remedies) cancel any unshipped portion of Products sold hereunder and stop any Products in transit until Buyer pays all amounts, including amounts payable hereunder, whether or not then due, which are owing to it by Buyer. Buyer shall in any event remain liable for all unpaid accounts.
9. **Cancellation; Etc.** Orders are not subject to rescheduling or cancellation unless Buyer indemnifies Omron against all related costs or expenses.
10. **Force Majeure.** Omron shall not be liable for any delay or failure in delivery resulting from causes beyond its control, including earthquakes, fires, floods, strikes or other labor disputes, shortage of labor or materials, accidents to machinery, acts of sabotage, riots, delay in or lack of transportation or the requirements of any government authority.
11. **Shipping; Delivery.** Unless otherwise expressly agreed in writing by Omron:
 - a. Shipments shall be by a carrier selected by Omron; Omron will not drop ship except in "break down" situations.
 - b. Such carrier shall act as the agent of Buyer and delivery to such carrier shall constitute delivery to Buyer;
 - c. All sales and shipments of Products shall be FOB shipping point (unless otherwise stated in writing by Omron), at which point title and risk of loss shall pass from Omron to Buyer; provided that Omron shall retain a security interest in the Products until the full purchase price is paid;
 - d. Delivery and shipping dates are estimates only; and
 - e. Omron will package Products as it deems proper for protection against normal handling and extra charges apply to special conditions.
12. **Claims.** Any claim by Buyer against Omron for shortage or damage to the Products occurring before delivery to the carrier must be presented in writing to Omron within 30 days of receipt of shipment and include the original transportation bill signed by the carrier noting that the carrier received the Products from Omron in the condition claimed.
13. **Warranties.** (a) **Exclusive Warranty.** Omron's exclusive warranty is that the Products will be free from defects in materials and workmanship for a period of twelve months from the date of sale by Omron (or such other period expressed in writing by Omron). Omron disclaims all other warranties, express or implied. (b) **Limitations.** OMRON MAKES NO WARRANTY OR REPRESENTATION, EXPRESS OR IMPLIED, ABOUT NON-INFRINGEMENT, MERCHANTABILITY OR FITNESS FOR A PARTICULAR PURPOSE OF THE PRODUCTS. BUYER ACKNOWLEDGES THAT IT ALONE HAS DETERMINED THAT THE PRODUCTS WILL SUITABLY MEET THE REQUIREMENTS OF THEIR INTENDED USE. Omron further disclaims all warranties and responsibility of any type for claims or expenses based on infringement by the Products or otherwise of any intellectual property right. (c) **Buyer Remedy.** Omron's sole obligation hereunder shall be, at Omron's election, to (i) replace (in the form originally shipped with Buyer responsible for labor charges for removal or replacement thereof) the non-complying Product, (ii) repair the non-complying Product, or (iii) repay or credit Buyer an amount equal to the purchase price of the non-complying Product; provided that in no event shall Omron be responsible for warranty, repair, indemnity or any other claims or expenses regarding the Products unless Omron's analysis confirms that the Products were properly handled, stored, installed and maintained and not subject to contamination, abuse, misuse or inappropriate modification. Return of any Products by Buyer must be approved in writing by Omron before shipment. Omron Companies shall not be liable for the suitability or unsuitability or the results from the use of Products in combination with any electrical or electronic components, circuits, system assemblies or any other materials or substances or environments. Any advice, recommendations or information given orally or in writing, are not to be construed as an amendment or addition to the above warranty. See <http://www.omron247.com> or contact your Omron representative for published information.
14. **Limitation on Liability; Etc.** OMRON COMPANIES SHALL NOT BE LIABLE FOR SPECIAL, INDIRECT, INCIDENTAL, OR CONSEQUENTIAL DAMAGES, LOSS OF PROFITS OR PRODUCTION OR COMMERCIAL LOSS IN ANY WAY CONNECTED WITH THE PRODUCTS, WHETHER SUCH CLAIM IS BASED IN CONTRACT, WARRANTY, NEGLIGENCE OR STRICT LIABILITY. Further, in no event shall liability of Omron Companies exceed the individual price of the Product on which liability is asserted.
15. **Indemnities.** Buyer shall indemnify and hold harmless Omron Companies and their employees from and against all liabilities, losses, claims, costs and expenses (including attorney's fees and expenses) related to any claim, investigation, litigation or proceeding (whether or not Omron is a party) which arises or is alleged to arise from Buyer's acts or omissions under these Terms or in any way with respect to the Products. Without limiting the foregoing, Buyer (at its own expense) shall indemnify and hold harmless Omron and defend or settle any action brought against such Companies to the extent based on a claim that any Product made to Buyer specifications infringed intellectual property rights of another party.
16. **Property; Confidentiality.** Any intellectual property in the Products is the exclusive property of Omron Companies and Buyer shall not attempt to duplicate it in any way without the written permission of Omron. Notwithstanding any charges to Buyer for engineering or tooling, all engineering and tooling shall remain the exclusive property of Omron. All information and materials supplied by Omron to Buyer relating to the Products are confidential and proprietary, and Buyer shall limit distribution thereof to its trusted employees and strictly prevent disclosure to any third party.
17. **Export Controls.** Buyer shall comply with all applicable laws, regulations and licenses regarding (i) export of products or information; (ii) sale of products to "forbidden" or other proscribed persons; and (iii) disclosure to non-citizens of regulated technology or information.
18. **Miscellaneous.** (a) **Waiver.** No failure or delay by Omron in exercising any right and no course of dealing between Buyer and Omron shall operate as a waiver of rights by Omron. (b) **Assignment.** Buyer may not assign its rights hereunder without Omron's written consent. (c) **Law.** These Terms are governed by the law of the jurisdiction of the home office of the Omron company from which Buyer is purchasing the Products (without regard to conflict of law principles). (d) **Amendment.** These Terms constitute the entire agreement between Buyer and Omron relating to the Products, and no provision may be changed or waived unless in writing signed by the parties. (e) **Severability.** If any provision hereof is rendered ineffective or invalid, such provision shall not invalidate any other provision. (f) **Setoff.** Buyer shall have no right to set off any amounts against the amount owing in respect of this invoice. (g) **Definitions.** As used herein, "including" means "including without limitation"; and "Omron Companies" (or similar words) mean Omron Corporation and any direct or indirect subsidiary or affiliate thereof.

Certain Precautions on Specifications and Use

1. **Suitability of Use.** Omron Companies shall not be responsible for conformity with any standards, codes or regulations which apply to the combination of the Product in the Buyer's application or use of the Product. At Buyer's request, Omron will provide applicable third party certification documents identifying ratings and limitations of use which apply to the Product. This information by itself is not sufficient for a complete determination of the suitability of the Product in combination with the end product, machine, system, or other application or use. Buyer shall be solely responsible for determining appropriateness of the particular Product with respect to Buyer's application, product or system. Buyer shall take application responsibility in all cases but the following is a non-exhaustive list of applications for which particular attention must be given: (i) Outdoor use, uses involving potential chemical contamination or electrical interference, or conditions or uses not described in this document. (ii) Use in consumer products or any use in significant quantities. (iii) Energy control systems, combustion systems, railroad systems, aviation systems, medical equipment, amusement machines, vehicles, safety equipment, and installations subject to separate industry or government regulations. (iv) Systems, machines and equipment that could present a risk to life or property. Please know and observe all prohibitions of use applicable to this Product. NEVER USE THE PRODUCT FOR AN APPLICATION INVOLVING SERIOUS RISK TO LIFE OR PROPERTY OR IN LARGE QUANTITIES WITHOUT ENSURING THAT THE SYSTEM AS A WHOLE HAS BEEN DESIGNED TO ADDRESS THE RISKS, AND THAT THE OMRON'S PRODUCT IS PROPERLY RATED AND INSTALLED FOR THE INTENDED USE WITHIN THE OVERALL EQUIPMENT OR SYSTEM.
2. **Programmable Products.** Omron Companies shall not be responsible for the user's programming of a programmable Product, or any consequence thereof.
3. **Performance Data.** Data presented in Omron Company websites, catalogs and other materials is provided as a guide for the user in determining suitability and does not constitute a warranty. It may represent the result of Omron's test conditions, and the user must correlate it to actual application requirements. Actual performance is subject to the Omron's Warranty and Limitations of Liability.
4. **Change in Specifications.** Product specifications and accessories may be changed at any time based on improvements and other reasons. It is our practice to change part numbers when published ratings or features are changed, or when significant construction changes are made. However, some specifications of the Product may be changed without any notice. When in doubt, special part numbers may be assigned to fix or establish key specifications for your application. Please consult with your Omron's representative at any time to confirm actual specifications of purchased Product.
5. **Errors and Omissions.** Information presented by Omron Companies has been checked and is believed to be accurate; however, no responsibility is assumed for clerical, typographical or proofreading errors or omissions.

OMRON AUTOMATION AND SAFETY • THE AMERICAS HEADQUARTERS • Chicago, IL USA • 847.843.7900 • 800.556.6766 • www.omron247.com

OMRON CANADA, INC. • HEAD OFFICE

Toronto, ON, Canada • 416.286.6465 • 866.986.6766 • www.omron247.com

OMRON ELECTRONICS DE MEXICO • HEAD OFFICE

México DF • 52.55.59.01.43.00 • 01-800-226-6766 • mela@omron.com

OMRON ELECTRONICS DE MEXICO • SALES OFFICE

Apodaca, N.L. • 52.81.11.56.99.20 • 01-800-226-6766 • mela@omron.com

OMRON ELETRÔNICA DO BRASIL LTDA • HEAD OFFICE

São Paulo, SP, Brasil • 55.11.2101.6300 • www.omron.com.br

OMRON ARGENTINA • SALES OFFICE

Cono Sur • 54.11.4783.5300

OMRON CHILE • SALES OFFICE

Santiago • 56.9.9917.3920

OTHER OMRON LATIN AMERICA SALES

54.11.4783.5300

OMRON EUROPE B.V. • Wegalaan 67-69, NL-2132 JD, Hoofddorp, The Netherlands. • +31 (0) 23 568 13 00 • www.industrial.omron.eu

Authorized Distributor:

Automation Control Systems

- Machine Automation Controllers (MAC) • Programmable Controllers (PLC)
- Operator interfaces (HMI) • Distributed I/O • Software

Drives & Motion Controls

- Servo & AC Drives • Motion Controllers & Encoders

Temperature & Process Controllers

- Single and Multi-loop Controllers

Sensors & Vision

- Proximity Sensors • Photoelectric Sensors • Fiber-Optic Sensors
- Amplified Photomicrosensors • Measurement Sensors
- Ultrasonic Sensors • Vision Sensors

Industrial Components

- RFID/Code Readers • Relays • Pushbuttons & Indicators
- Limit and Basic Switches • Timers • Counters • Metering Devices
- Power Supplies

Safety

- Laser Scanners • Safety Mats • Edges and Bumpers • Programmable Safety Controllers • Light Curtains • Safety Relays • Safety Interlock Switches