

K3G097-AK36-55

EC dual centrifugal fan

forward curved, dual inlet
with housing, Automotive



ebm-papst Mulfingen GmbH & Co. KG

Bachmühle 2

D-74673 Mulfingen

Phone: +49(0)7938/81-0

Fax: +49(0)7938/81-110

info1@de.ebmpapst.com

www.ebmpapst.com

Nominal data

Type	K3G097-AK36-55		
Motor	M3G074-CF		
Nominal voltage	VDC	13	
Nominal voltage range	VDC	9 .. 15	
Speed	min ⁻¹	3740	
Power input	W	385	
Max. ambient temperature	°C	70	

ml = max. load · me = max. efficiency · rfa = running at free air · cs = customer specs · cu = customer unit
Subject to alterations

EC dual centrifugal fan

forward curved, dual inlet
with housing, Automotive

Technical features

Size	97 mm
Operation mode	S1
Direction of rotation	Clockwise, seen on rotor
Humidity class	F3-2
Insulation class	"B"
Cable exit	Variable
Cooling bore / aperture	Rotor-side
Motor bearing	Ball bearing
Mass	2.6 kg
Housing material	PP plastic, color: black (in accordance with UL 94 HB)
Material of impeller	PA plastic
Motor protection	Reverse polarity and locked-rotor protection
Type of protection	IP 24 KM

EC dual centrifugal fan

forward curved, dual inlet
with housing, Automotive

Product drawing

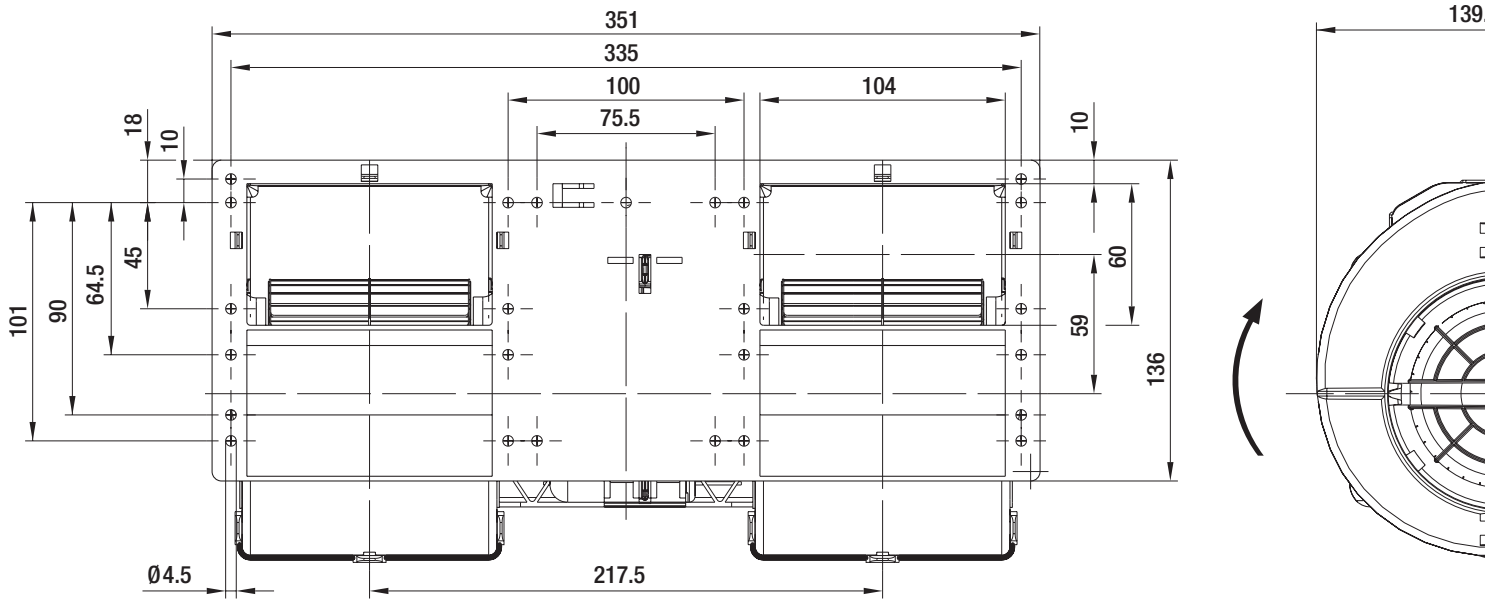

EC dual centrifugal fan

forward curved, dual inlet
with housing, Automotive

Connection screen

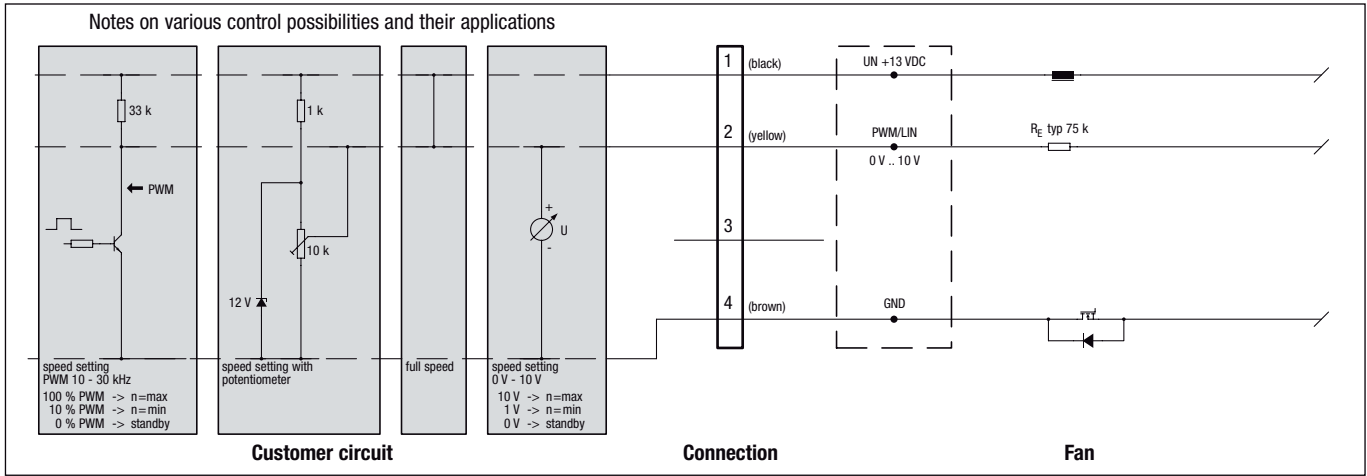

Charts: Air flow

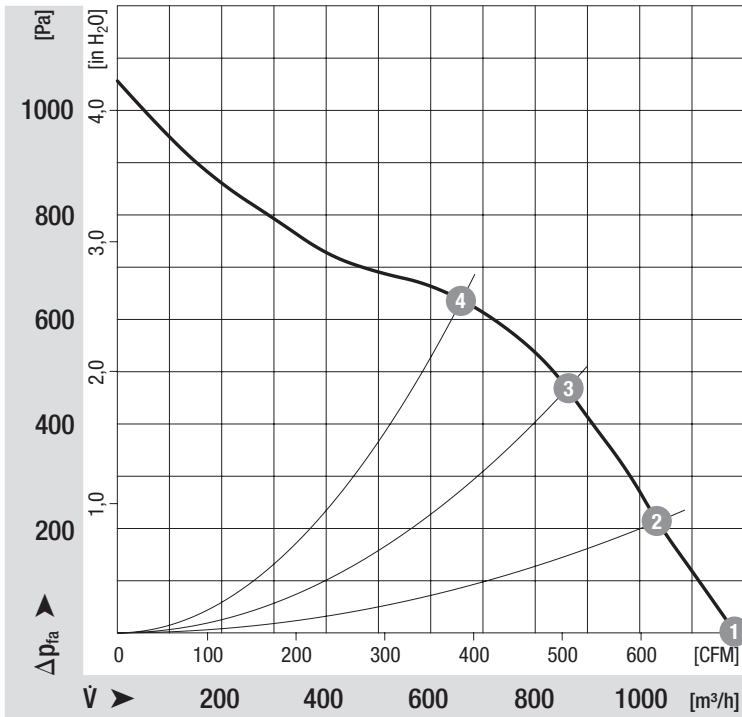

Measured values

	n	P ₁	η _{Ges}
	min ⁻¹	W	%
1	3740	385	34
2	4015	356	41
3	4475	341	46
4	4835	292	47