

NEW

# 28+Gbps 0.5mm pitch Board to Board Connector

## IT9 Series



### Mechanical features

- 3row or 4row 0.5mm pitch SMT array
- Number of contacts : 84pos, 224pos.
- Mating length : 2.0mm
- High density
  - 50 Differential pairs / linear inch (224pos.)
- Blade variation
  - Differential signal blade (GSSGSSG...)
  - Power & low signal blade (SSSS...)
- Large mating guide  $\pm 1.6\text{mm}$
- Multiple connectors are allowed on the same PCB
- Robustness (Large retention pegs)

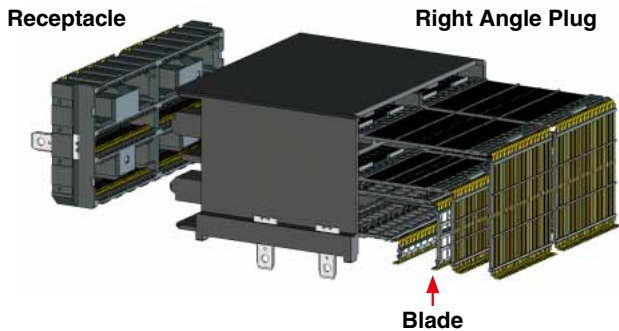

### Signal integrity features

#### ● Insertion Loss-to-Crosstalk-Ratio (ICR)

The insertion loss-to-crosstalk ratio (ICR) with 5-aggressor differential FEXT meets the IEEE802.3ap specification for 28Gbps with plenty of margins.

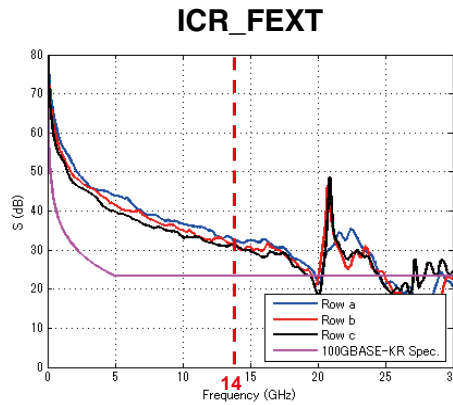
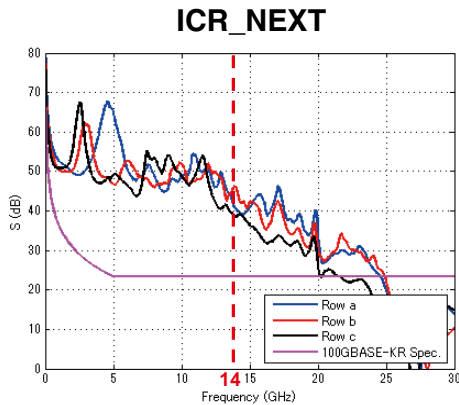

### Transmission blade variation

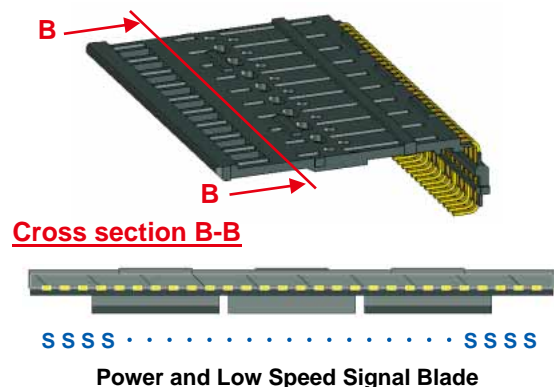
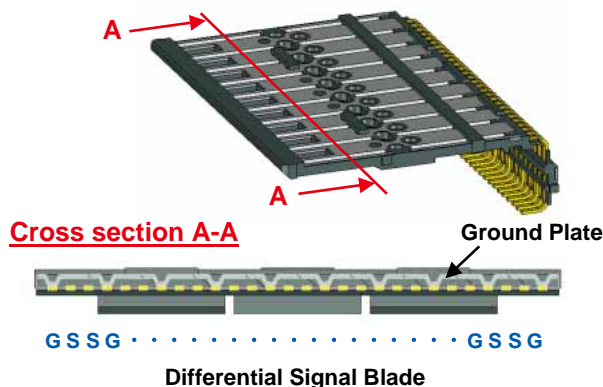

In cases where the application will demand a high level of reliability, such as automotive, please contact a company representative for further information.

Sep. 1. 2020 Copyright 2020 HIROSE ELECTRIC CO., LTD. All Rights Reserved.



## Pin Assignment

84pos. : IT9M2-84P-0.5SH3 – IT9M2-84S-0.5SV3

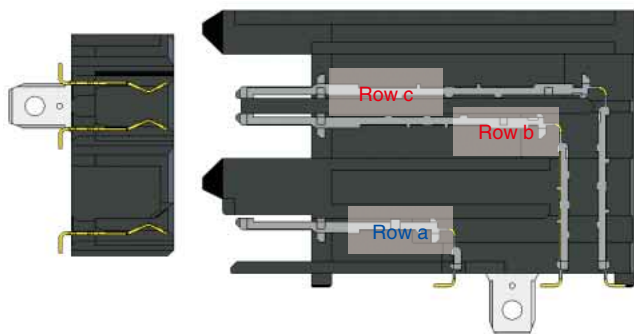

Number of Contacts	Column	Pin Number																											
		28	27	26	25	24	23	22	21	20	19	18	17	16	15	14	13	12	11	10	9	8	7	6	5	4	3	2	1
84	Row c	G	S	S	G	S	S	G	S	S	G	S	S	G	S	S	G	S	S	G	S	S	G	S	S	G	S	S	G
	Row b	G	S	S	G	S	S	G	S	S	G	S	S	G	S	S	G	S	S	G	S	S	G	S	S	G	S	S	G
	Row a	U	U	U	U	U	U	U	U	U	U	U	U	U	U	U	U	U	U	U	U	U	U	U	U	U	U	U	U
Row c : For High Speed Signal Row b : For High Speed Signal Row a : For Power and Low Speed Signal														S : Differential Signal Pin (36 Pins / 18 Pairs) G : Dedicated Ground Pin (20 Pins) U : Universal Pin (28 Pins)															

224pos. : IT9M2-224P-0.5SH4 – IT9M2-224S-0.5SV4

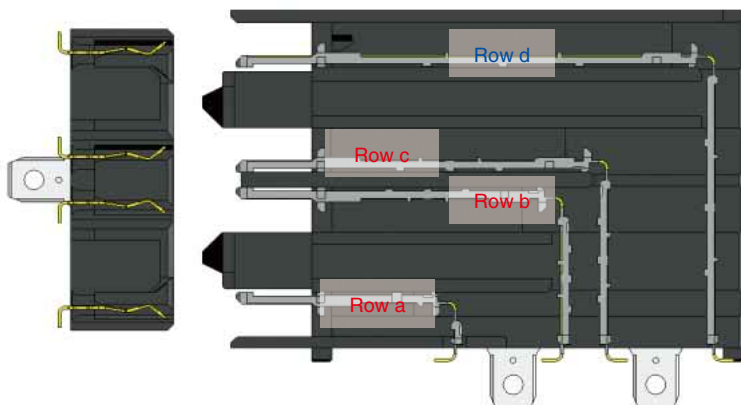

Number of Contacts	Column	Pin Number																											
		28	27	26	25	24	23	22	21	20	19	18	17	16	15	14	13	12	11	10	9	8	7	6	5	4	3	2	1
224	Row d	U	U	U	U	U	U	U	U	U	U	U	U	U	U	U	U	U	U	U	U	U	U	U	U	U	U	U	U
	Row c	G	S	S	G	S	S	G	S	S	G	S	S	G	S	S	G	S	S	G	S	S	G	S	S	G	S	S	G
	Row b	G	S	S	G	S	S	G	S	S	G	S	S	G	S	S	G	S	S	G	S	S	G	S	S	G	S	S	G
	Row a	G	S	S	G	S	S	G	S	S	G	S	S	G	S	S	G	S	S	G	S	S	G	S	S	G	S	S	G
	Column	56	55	54	53	52	51	50	49	48	47	46	45	44	43	42	41	40	39	38	37	36	35	34	33	32	31	30	29
	Row d	U	U	U	U	U	U	U	U	U	U	U	U	U	U	U	U	U	U	U	U	U	U	U	U	U	U	U	U
	Row c	G	S	S	G	S	S	G	S	S	G	S	S	G	S	S	G	S	S	G	S	S	G	S	S	G	S	S	G
	Row b	G	S	S	G	S	S	G	S	S	G	S	S	G	S	S	G	S	S	G	S	S	G	S	S	G	S	S	G
	Row a	G	S	S	G	S	S	G	S	S	G	S	S	G	S	S	G	S	S	G	S	S	G	S	S	G	S	S	G
	Row d : For Power and Low Speed Signal Row c : For High Speed Signal Row b : For High Speed Signal Row a : For High Speed Signal														S : Differential Signal Pin (108 Pins / 54 Pairs) G : Dedicated Ground Pin (60 Pins) U : Universal Pin (56 Pins)														

## Signal Integrity

### Pin assignment

#### Via-Connector-via

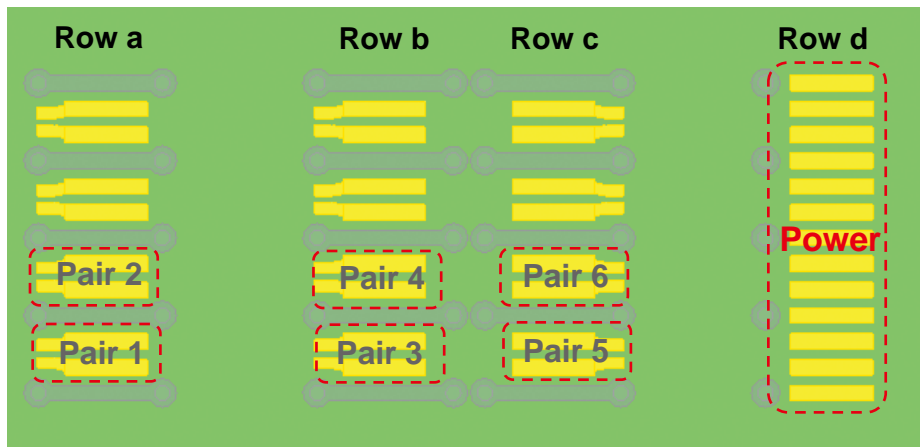

### Insertion Loss and Return Loss

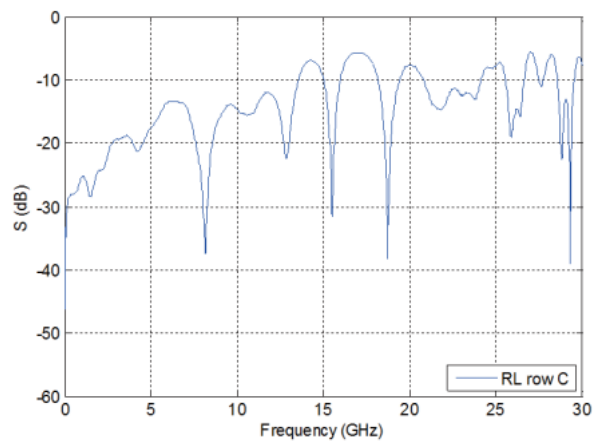
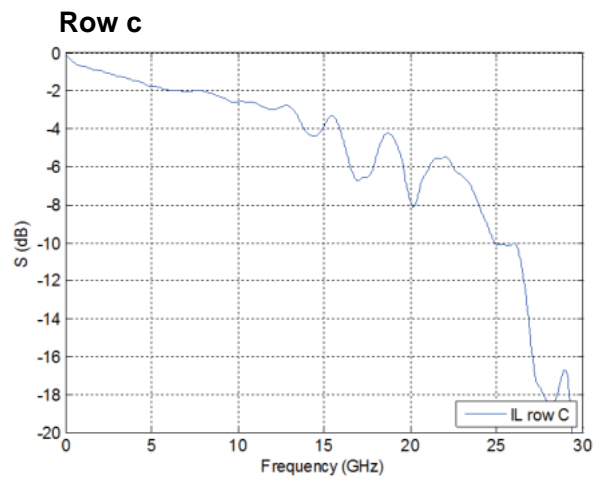
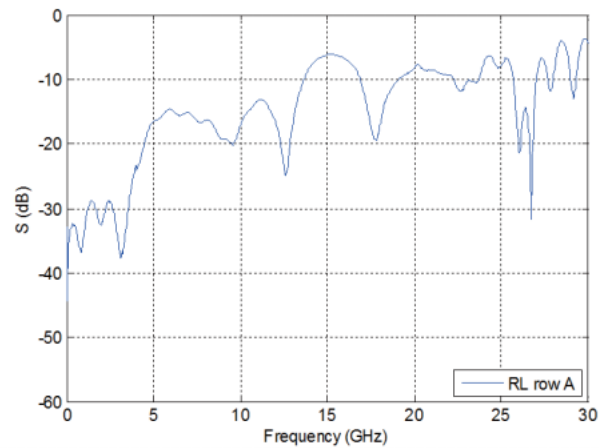
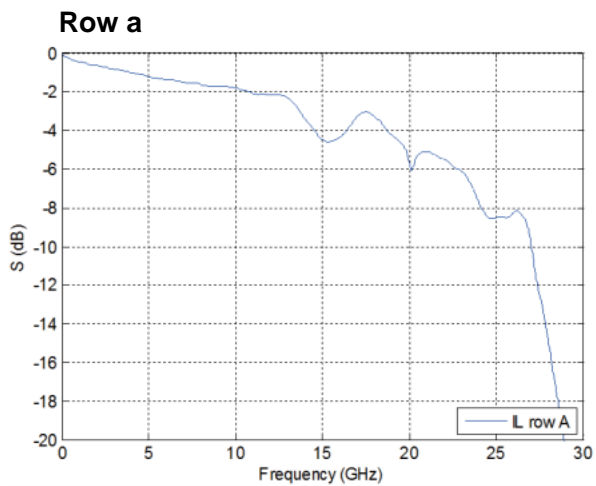

● Pin assignment

Via-Connector-via

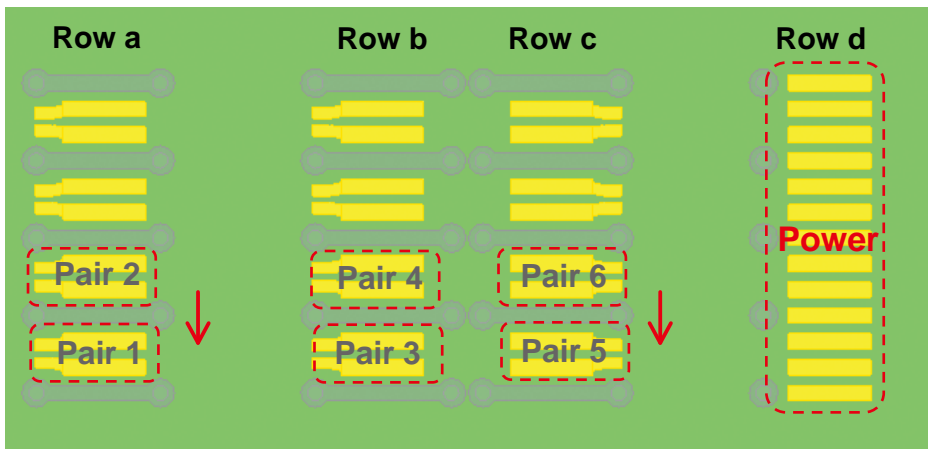

● Crosstalk

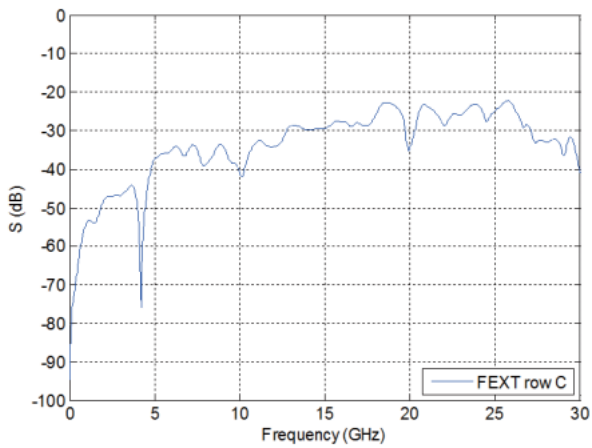
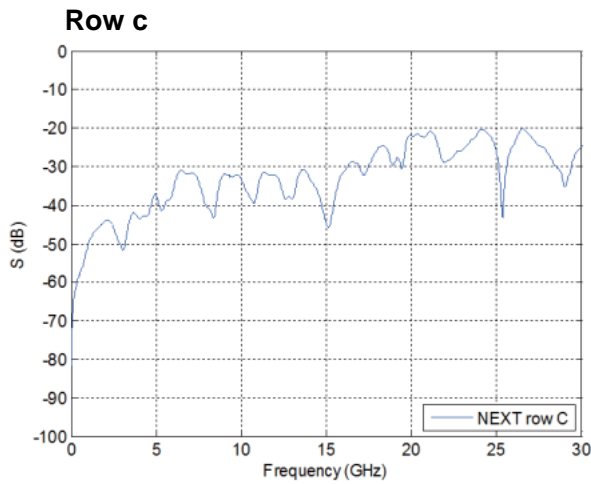
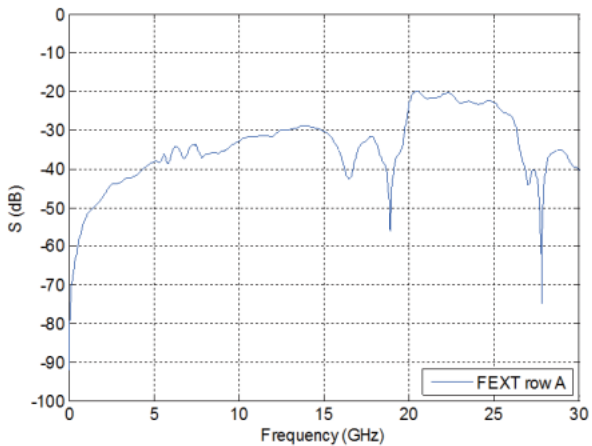
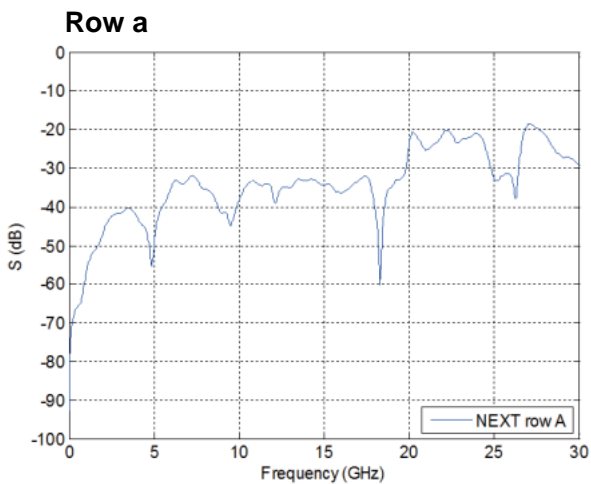

Sep. 1. 2020 Copyright 2020 HIROSE ELECTRIC CO., LTD. All Rights Reserved.

### ● Insertion-loss-to-crosstalk ratio (ICR)

The insertion-loss-to-crosstalk ratio (ICR) with 5-aggressor meets the extrapolated IEEE 802.3ap specification to 14GHz with plenty of margins.

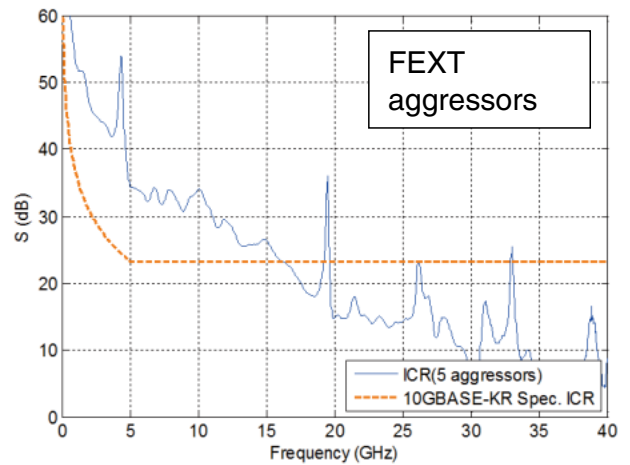
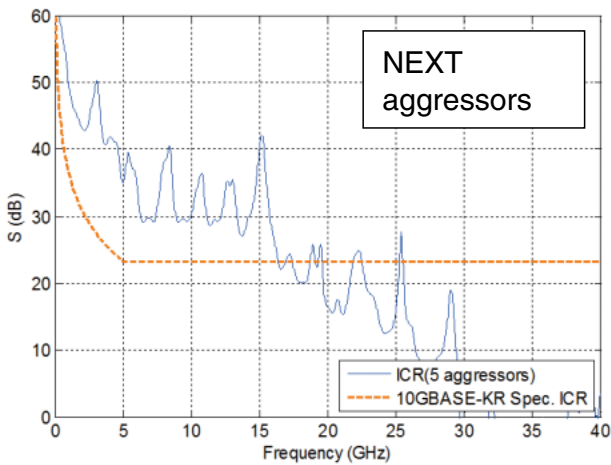
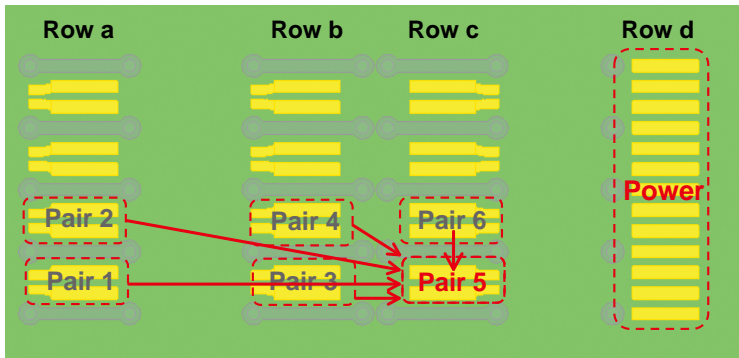
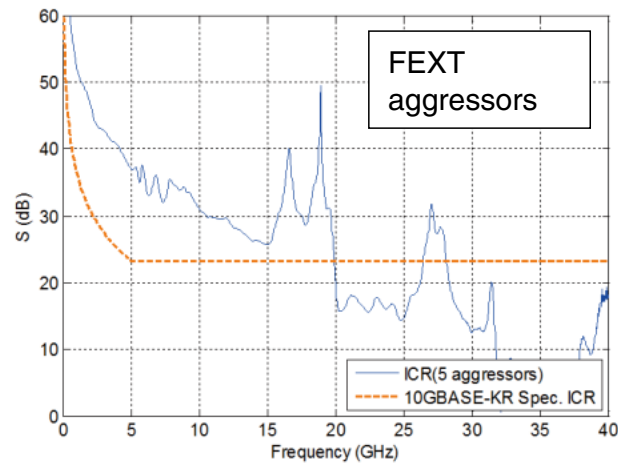
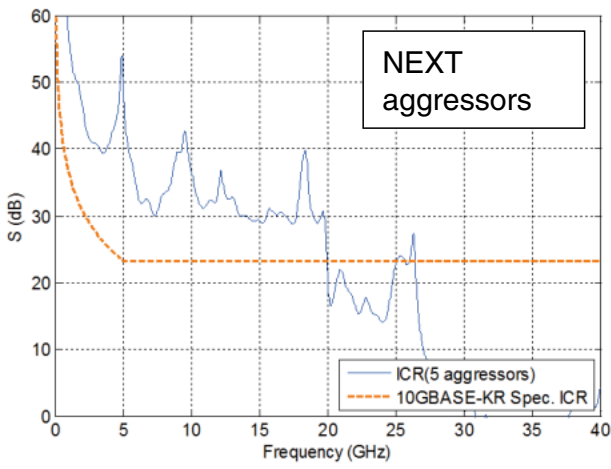
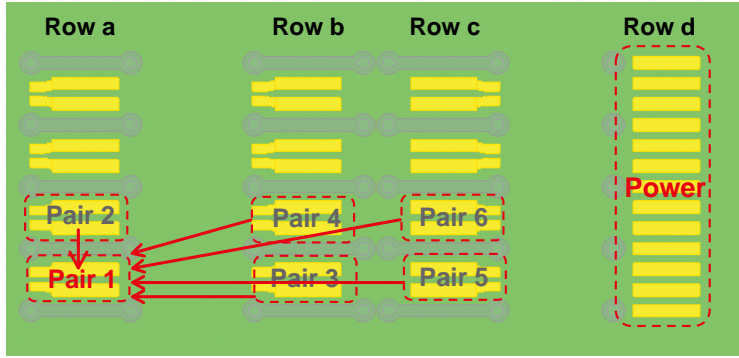

Sep. 1. 2020 Copyright 2020 HIROSE ELECTRIC CO., LTD. All Rights Reserved.

## ■ Receptacle

### ● 3row type : IT9M2-84S-0.5SV3

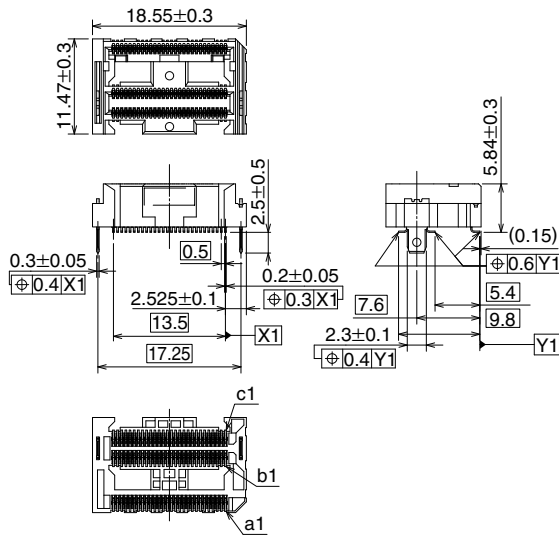

### ● 4row type : IT9M2-224S-0.5SV4

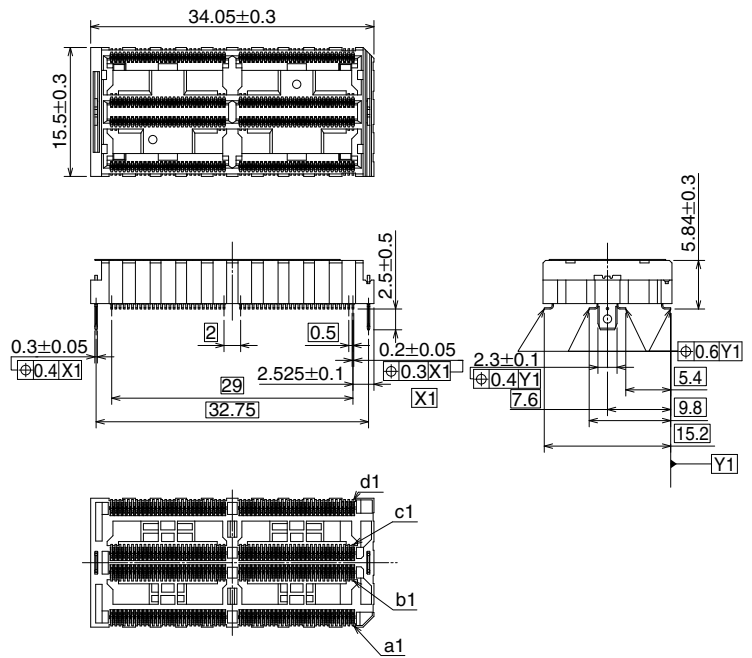
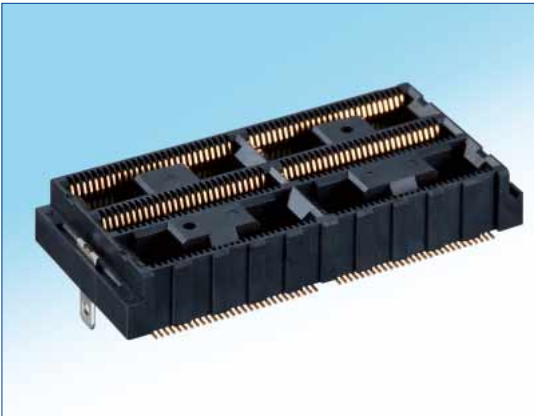

Part No.	HRS No.	No. of Contacts
IT9M2-84S-0.5SV3	636-1610-0	84
IT9M2-224S-0.5SV4	636-1611-0	224

## ■ Right angle plug

### ● 3row type : IT9M2-84P-0.5SH3

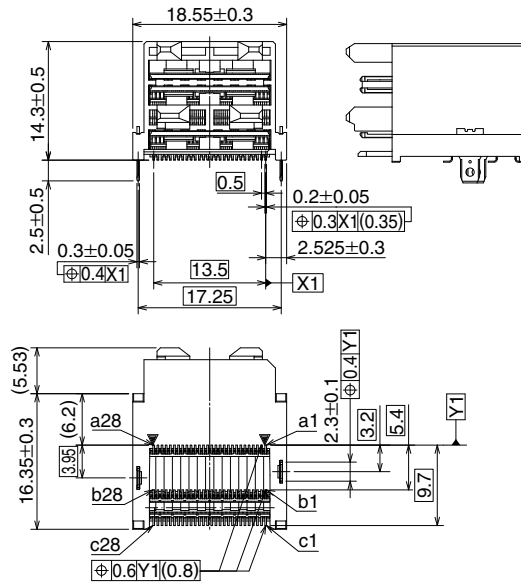

### ● 4row type : IT9M2-224P-0.5SH4

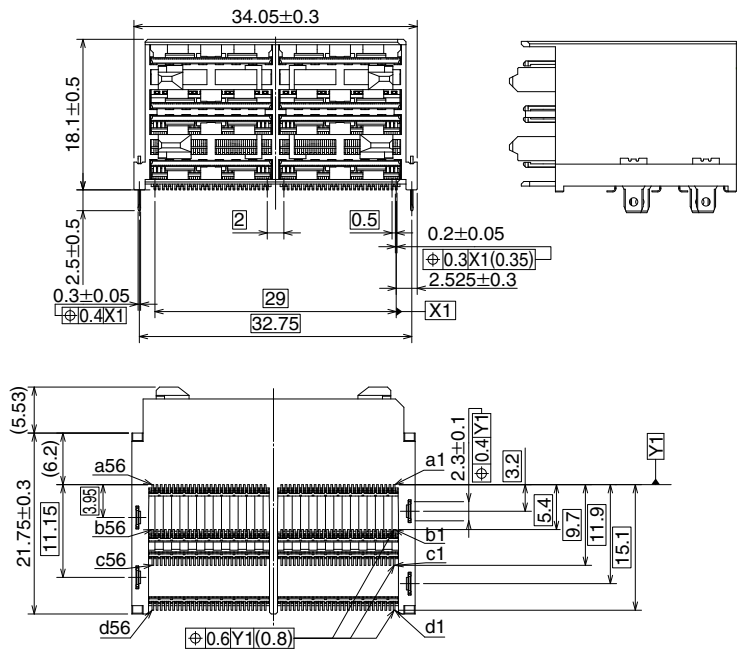

Part No.	HRS No.	No. of Contacts
IT9M2-84P-0.5SH3	636-1606-0	84
IT9M2-224P-0.5SH4	636-1607-0	224

## Recommended PCB Mouting Pattern

(Stencil thickness : t=0.13mm)

### ● Receptacle

IT9M2-84S-0.5SV3

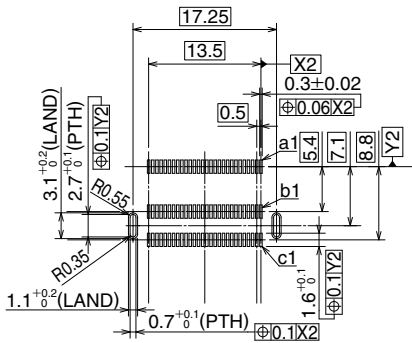

IT9M2-224S-0.5SV4

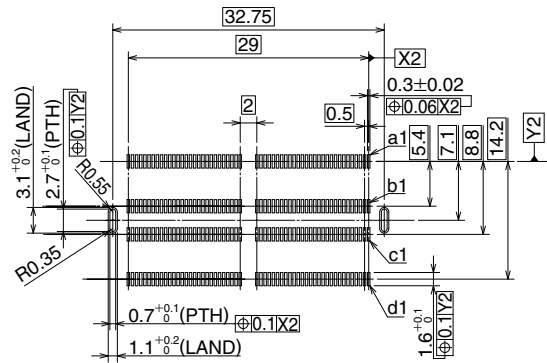

### ● Right angle plug

IT9M2-84P-0.5SH3

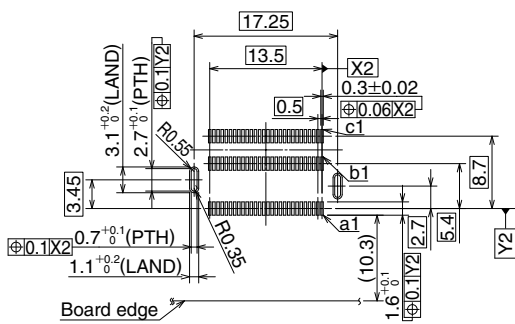

IT9M2-224P-0.5SH4

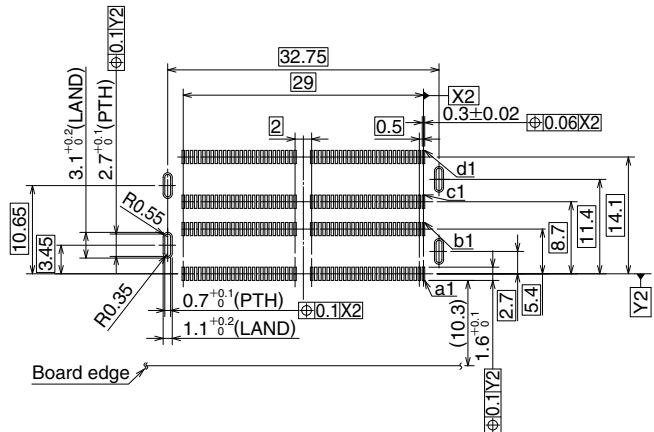

## ■ Processing recommendations

### ● Mating Alignment Requirements

Maximum mating guidance is up to  $\pm 1.6\text{mm}$  in both longitudinal and lateral directions.

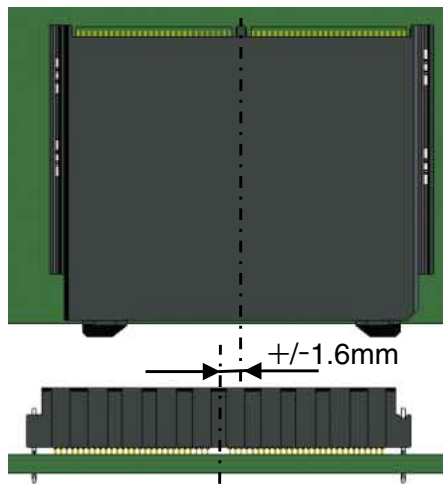

Longitudinal

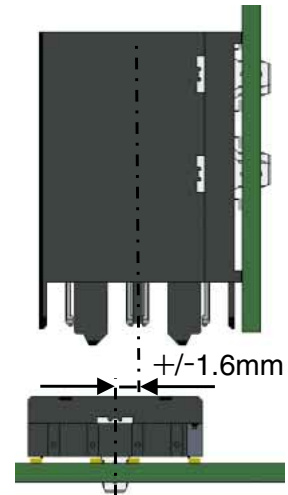

Lateral

These values do not include the influence of misalignment in other axis nor rotation / inclination in the same time, except for the misalignment in the single axis shown in each figure.

### ● Mating Angle Requirements

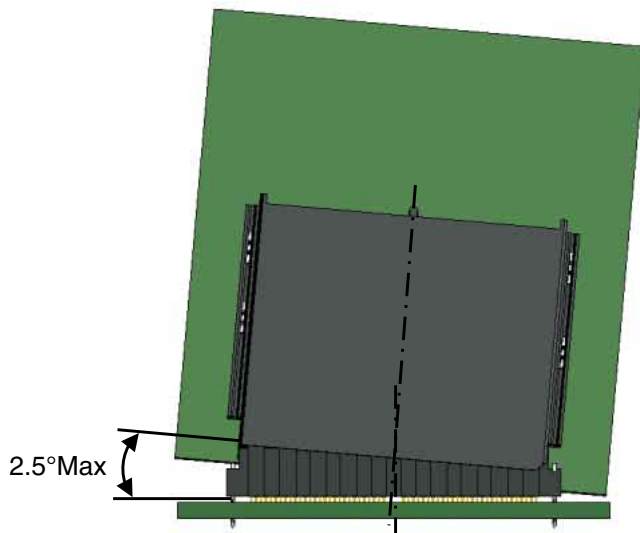

Longitudinal

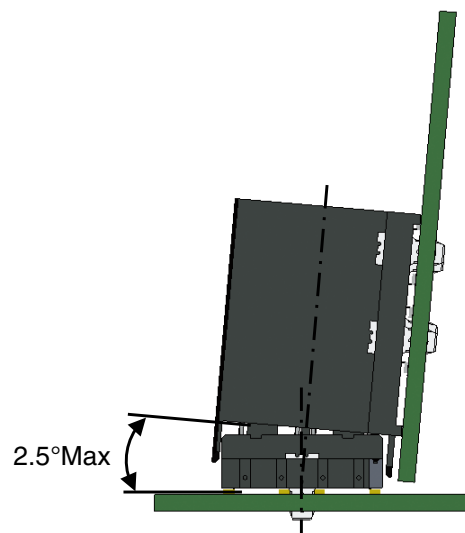

Lateral

## Mounting Temperature Profile (Reference)

Profile Feature	Condition	Note
Preheat/Soak Temperature Min (T <sub>smin</sub> ) Temperature Max (T <sub>smax</sub> ) Time (t <sub>s</sub> ) from (T <sub>smin</sub> to T <sub>smax</sub> )	150°C 200°C 60-120 seconds	Soak requirements should be determined by board design, oven capability, and paste activation requirements. Caution- "oversoaking" may exhaust flux and affect soldering.
Ramp-up rate (TL to T <sub>p</sub> )	3°C/second max.	Other components may limit ramp rate to 2°C/sec.
Liquidous temperature (T <sub>L</sub> ) Time (t <sub>L</sub> ) maintained above T <sub>L</sub>	217°C 60-150 seconds	Shorter t <sub>L</sub> may require higher peak temperature.
Peak package body temperature (T <sub>p</sub> )	245°C max.	Cooler peak temperatures may require longer t <sub>L</sub> . For users T <sub>p</sub> must not exceed the classification temp (T <sub>C</sub> ) of 250°C.
Time (t <sub>p</sub> )* within 5°C of the specified classification temperature (T <sub>c</sub> )	30 seconds max.	
Ramp-down rate (T <sub>p</sub> to T <sub>L</sub> )	6°C/second max.	
Package Body Exposure Limit at Maximum Temperature	5 seconds	Adjust profile if maximum exposure limits approached or exceeded.

All temperatures refer to the center of the connector body, measured on the connector body surface that is facing up during assembly reflow. Reflow profiles in this document are based according to IPC/JEDEC J-STD-020D.1 and are for preconditioning. Actual board assembly profiles should be developed based on specific process needs and board designs and should not exceed the parameters in the table above.

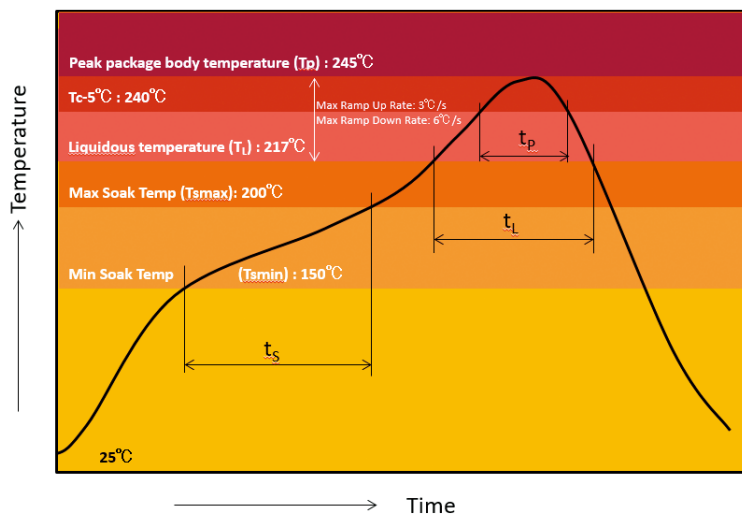

Different solder pastes have different thermal performance characteristics. Consult with paste manufacturer for optimum profile setting.

**USA:**

**HIROSE ELECTRIC (U.S.A.), INC. HEADQUARTERS CHICAGO OFFICE**  
2300 Warrenville Road, Suite 150,  
Downers Grove, IL 60515  
Phone : +1-630-282-6700  
<http://www.hirose.com/us/>

**USA:**

**HIROSE ELECTRIC (U.S.A.), INC. SAN JOSE OFFICE**  
2841 Junction Ave, Suite 200  
San Jose, CA. 95134  
Phone : +1-408-253-9640  
Fax : +1-408-253-9641  
<http://www.hirose.com/us/>

**USA:**

**HIROSE ELECTRIC (U.S.A.), INC. DETROIT OFFICE (AUTOMOTIVE)**  
17197 N. Laurel Park Drive, Suite 253,  
Livonia, MI 48152  
Phone : +1-734-542-9963  
Fax : +1-734-542-9964  
<http://www.hirose.com/us/>

**USA:**

**HIROSE ELECTRIC (U.S.A.), INC. BOSTON OFFICE**  
300 Brickstone Square Suite 201,  
Andover, MA 01810  
Phone : +1-978-662-5255

**THE NETHERLANDS:**

**HIROSE ELECTRIC EUROPE B.V.**  
Hogehillweg #8 1101 CC Amsterdam Z-0  
Phone : +31-20-6557460  
Fax : +31-20-6557469  
<http://www.hirose.com/eu/>

**GERMANY:**

**HIROSE ELECTRIC EUROPE B.V. GERMAN BRANCH**  
Schoenbergstr. 20, 73760 ostfildern  
Phone : +49-711-456002-1  
Fax : +49-711-456002-299  
<http://www.hirose.com/eu/>

**GERMANY:**

**HIROSE ELECTRIC EUROPE B.V. NUREMBERG OFFICE**  
Neumeyerstrasse 22-26, 90411 Nurnberg  
Phone : +49-911 32 68 89 63  
Fax : +49-911 32 68 89 69  
<http://www.hirose.com/eu/>

**GERMANY:**

**HIROSE ELECTRIC EUROPE B.V. HANOVER OFFICE**  
Bayernstr. 3, Haus C 30855 Langenhagen, Germany  
Phone : +49-511 97 82 61 30  
Fax : +49-511 97 82 61 35  
<http://www.hirose.com/eu/>

**FRANCE:**

**HIROSE ELECTRIC EUROPE B.V. PARIS OFFICE**  
130 Avenue Joseph Kessel, Bat E, 78960  
Voisins le Bretonneux, France  
Phone : +33-1-85764886  
Fax : +33-1-85764823  
<http://www.hirose.com/eu/>

**UNITED KINGDOM:**

**HIROSE ELECTRIC EUROPE BV (UK BRANCH)**  
4 Newton Court, Kelvin Drive, Knowlhill,  
Milton Keynes, MK5 8NH  
Phone : +44-1908 202050  
Fax : +44-1908 202058  
<http://www.hirose.com/eu/>

**CHINA:**

**HIROSE ELECTRIC (CHINA) CO., LTD. (SHANGHAI, HEADQUARTERS)**  
18, Enterprise Center Tower 2, 209# Gong He  
Road, Jing'an District, Shanghai, CHINA 200070  
Phone : +86-21-6391-3355  
Fax : +86-21-6391-3335  
<http://www.hirose.com/cn/>

**CHINA:**

**HIROSE ELECTRIC (CHINA) CO., LTD. BEIJING BRANCH**  
A1001, Ocean International Center, Building 56# East 4th  
Ring Middle Road, ChaoYang District, Beijing, 100025  
Phone : +86-10-5165-9332  
Fax : +86-10-5908-1381  
<http://www.hirose.com/cn/>

**CHINA:**

**HIROSE ELECTRIC (CHINA) CO., LTD. SHENZHEN BRANCH**  
Room 09-13, 19/F, Office Tower Shun Hing Square, Di Wang Commercial Centre,  
5002 Shen Nan Dong Road, Shenzhen City, Guangdong Province, 518008  
Phone : +86-755-8207-0851  
Fax : +86-755-8207-0873  
<http://www.hirose.com/cn/>

**HONG KONG:**

**HIROSE ELECTRIC HONGKONG TRADING CO., LTD.**  
Room 1001, West Wing, Tsim Sha Tsui Centre, 66  
Mody Road, Tsim Sha Tsui East, Kowloon, Hong Kong  
Phone : +852-2803-5338  
Fax : +852-2591-6560  
<http://www.hirose.com/hk/>

**TAIWAN:**

**HIROSE ELECTRIC TAIWAN CO., LTD.**  
103 8F, No.87, Zhengzhou Rd., Taipei  
Phone : +886-2-2555-7377  
Fax : +886-2-2555-7355  
<http://www.hirose.com/tw/>

**KOREA:**

**HIROSE KOREA CO., LTD.**  
143, Gongdan 1-daero, Siheung-si,  
Gyeonggi-do, 15084, Korea  
Phone : +82-31-496-7000  
Fax : +82-31-496-7100  
<http://www.hirose.co.kr/>

**SINGAPORE:**

**HIROSE ELECTRIC SINGAPORE PTE. LTD.**  
03, Anson Road, #20-01, Springleaf Tower,  
Singapore 079909  
Phone : +65-6324-6113  
Fax : +65-6324-6123  
<http://www.hirose.com/sg/>

**INDIA:**

**HIROSE ELECTRIC SINGAPORE PTE. LTD. DELHI LIAISON OFFICE**  
Office NO.552, Regus-Green Boulevard, Level5, Tower C,  
Sec62, Plot B-9A, Block B, Noida, 201301, Uttar Pradesh, India  
Phone : +91-12-660-8018  
Fax : +91-120-4804949  
<http://www.hirose.com/sg/>

**INDIA:**

**HIROSE ELECTRIC SINGAPORE PTE. LTD. BANGALORE LIAISON OFFICE**  
Unit No-403, 4th Floor, No-84, Barton Centre, Mahatma  
Gandhi (MG) Road, Bangalore 560 001, Karnataka, India  
Phone : +91-80-4120 1907  
Fax : +91-80-4120 9908  
<http://www.hirose.com/sg/>

**MALAYSIA:**

**PENANG REPRESENTATIVE OFFICE**  
73-3-1, Ideal@The One, Jalan Mahsuri, Bayan  
Lepas Penang, 11950, Malaysia  
Phone : +604-648-5536  
<http://www.hirose.com/sg/>

**THAILAND:**

**BANGKOK OFFICE (REPRESENTATIVE OFFICE)**  
Unit 4703, 47th FL., 1 Empire Tower, South Sathorn  
Road, Yannawa, Sathorn, Bangkok 10120 Thailand  
Phone : +66-2-686-1255  
Fax : +66-2-686-3433  
<http://www.hirose.com/sg/>

**HIROSE ELECTRIC CO., LTD.**

2-6-3, Nakagawa Chuoh, Tsuzuki-Ku, Yokohama-Shi 224-8540, JAPAN  
TEL: +81-45-620-3526 Fax: +81-45-591-3726  
<http://www.hirose.com>  
<http://www.hirose-connectors.com>