

Jun.1.2023 Copyright 2023 HIROSE ELECTRIC CO., LTD. All Rights Reserved.  
In case of consideration for using Automotive equipment / device which demand high reliability, kindly contact our sales window correspondents.

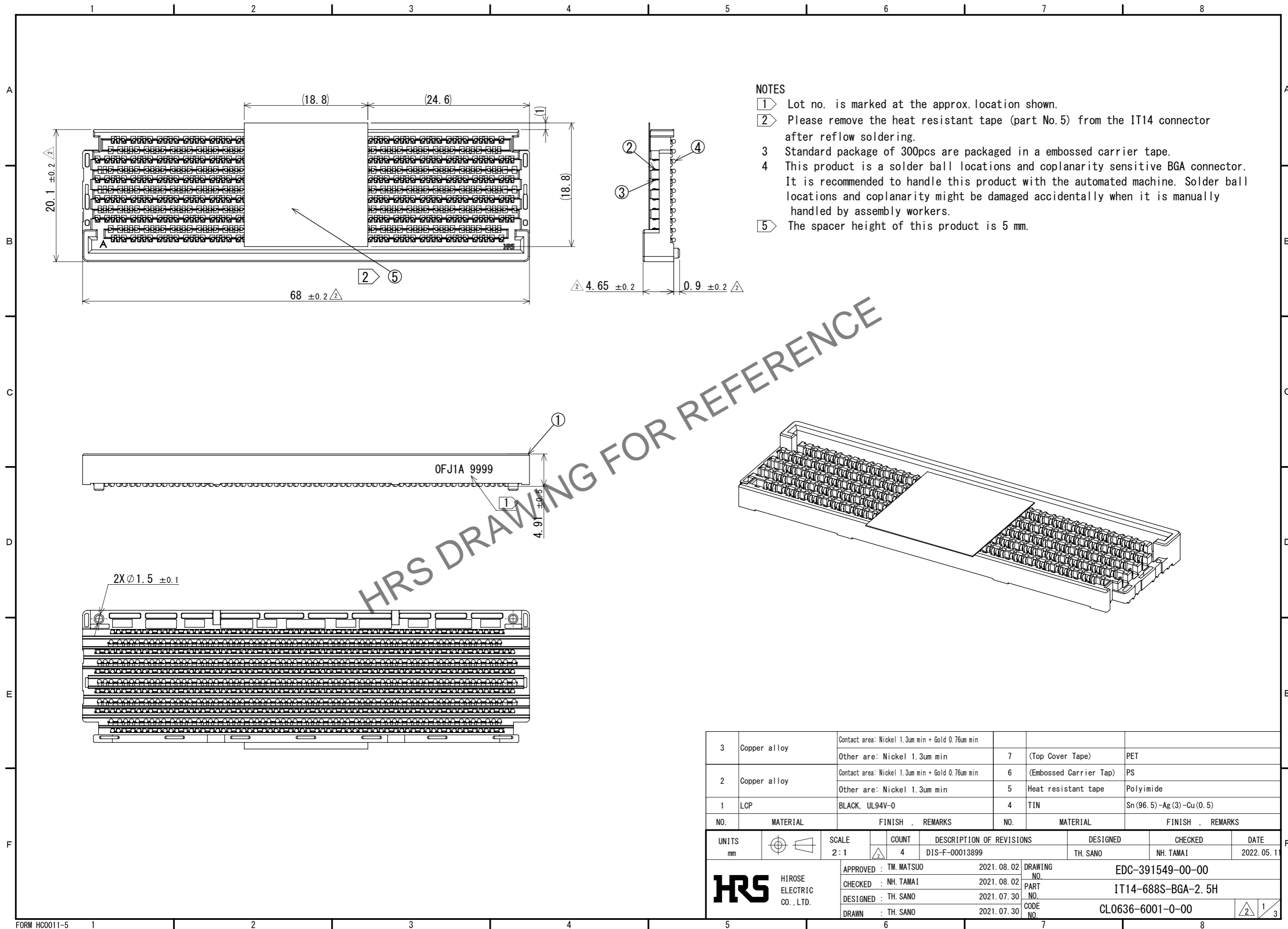

**NOTES**

- ① Lot no. is marked at the approx. location shown.
- ② Please remove the heat resistant tape (part No.5) from the IT14 connector after reflow soldering.
- ③ Standard package of 300pcs are packaged in a embossed carrier tape.
- ④ This product is a solder ball locations and coplanarity sensitive BGA connector. It is recommended to handle this product with the automated machine. Solder ball locations and coplanarity might be damaged accidentally when it is manually handled by assembly workers.
- ⑤ The spacer height of this product is 5 mm.

3	Copper alloy	Contact area: Nickel 1.3um min + Gold 0.76um min						
		Other are: Nickel 1.3um min	7	(Top Cover Tape)	PET			
2	Copper alloy	Contact area: Nickel 1.3um min + Gold 0.76um min	6	(Embossed Carrier Tap)	PS			
		Other are: Nickel 1.3um min	5	Heat resistant tape	Polyimide			
1	LCP	BLACK, UL94V-0	4	TIN	Sn (96.5) -Ag (3) -Cu (0.5)			
NO.	MATERIAL	FINISH	REMARKS	NO.	MATERIAL	FINISH	REMARKS	
UNITS		SCALE	COUNT	DESCRIPTION OF REVISIONS		DESIGNED	CHECKED	DATE
mm		2:1	4	DIS-F-00013899		TH. SANO	NH. TAMAI	2022.05.11
<b>HRS</b> HIROSE ELECTRIC CO., LTD.		APPROVED :	TM. MATSUO	2021.08.02	DRAWING NO.		EDC-391549-00-00	
		CHECKED :	NH. TAMAI	2021.08.02	PART NO.		IT14-688S-BGA-2.5H	
		DESIGNED :	TH. SANO	2021.07.30	CODE NO.		CL0636-6001-0-00	
		DRAWN :	TH. SANO	2021.07.30				

Jun.1.2023 Copyright 2023 HIROSE ELECTRIC CO., LTD. All Rights Reserved.  
 In case of consideration for using Automotive equipment / device which demand high reliability, kindly contact our sales window correspondents.

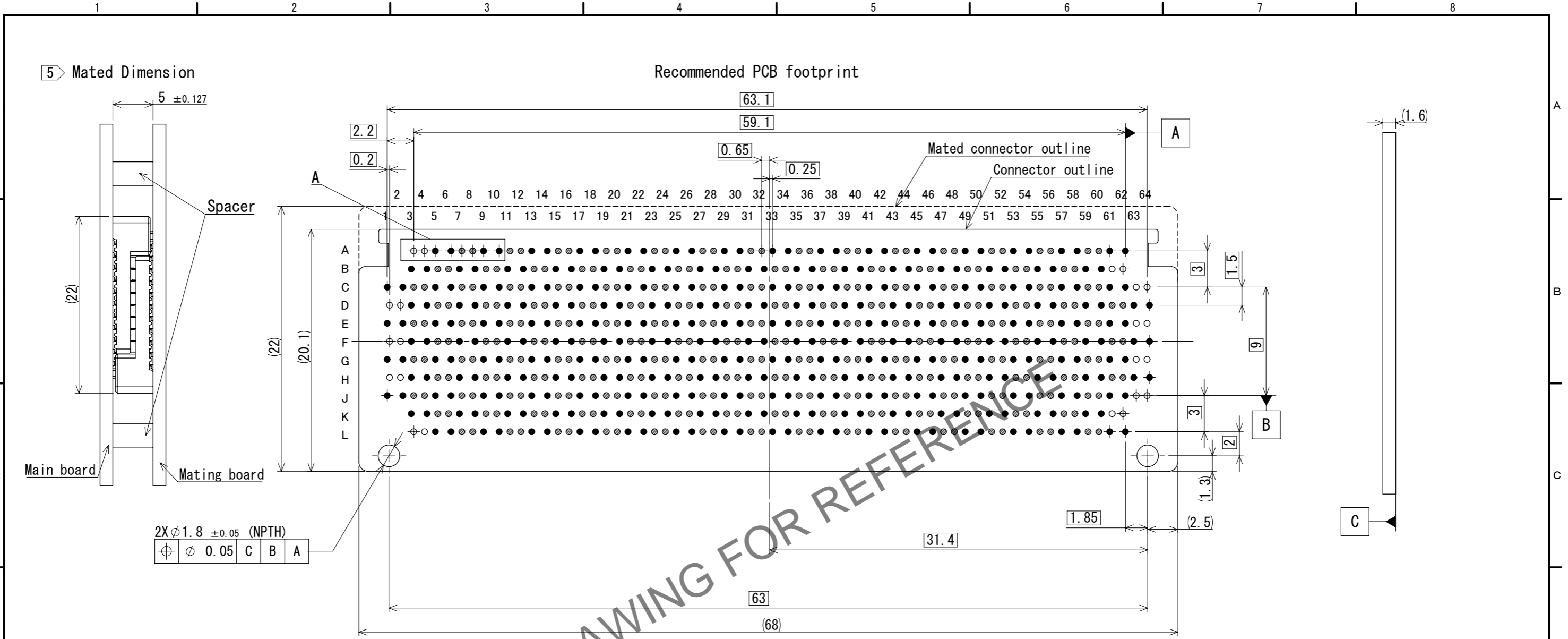

HRS DRAWING FOR REFERENCE

PIN MAPPING (Main board - Mating board)										
/	/	A3-L3	A4-L4	A5-L5	----	A60-L60	A61-L61	A62-L62	/	/
/	/	B3-K3	B4-K4	B5-K5	----	B60-K60	B61-K61	B62-K62	/	/
C1-J1	C2-J2	C3-J3	C4-J4	C5-J5	----	C60-J60	C61-J61	C62-J62	C63-J63	C64-J64
D1-H1	D2-H2	D3-H3	D4-H4	D5-H5	----	D60-H60	D61-H61	D62-J62	D63-H63	D64-H64
E1-G1	E2-G2	E3-G3	E4-G4	E5-G5	----	E60-G60	E61-G61	E62-G62	E63-G63	E64-G64
F1-F1	F2-F2	F3-F3	F4-F4	F5-F5	----	F60-F60	F61-F61	F62-F62	F63-F63	F64-F64
G1-E1	G2-E2	G3-E3	G4-E4	G5-E5	----	G60-E60	G61-E61	G62-E62	G63-E63	G64-E64
H1-D1	H2-D2	H3-D3	H4-D4	H5-D5	----	H60-D60	H61-D61	H62-D62	H63-D63	H64-D64
J1-C1	J2-C2	J3-C3	J4-C4	J5-C5	----	J60-C60	J61-C61	J62-C62	J63-C63	J64-C64
/	/	K3-B3	K4-B4	K5-B5	----	K60-B60	K61-B61	K62-B62	/	/
/	/	L3-A3	L4-A4	L5-A5	----	L60-A60	L61-A61	L62-A62	/	/

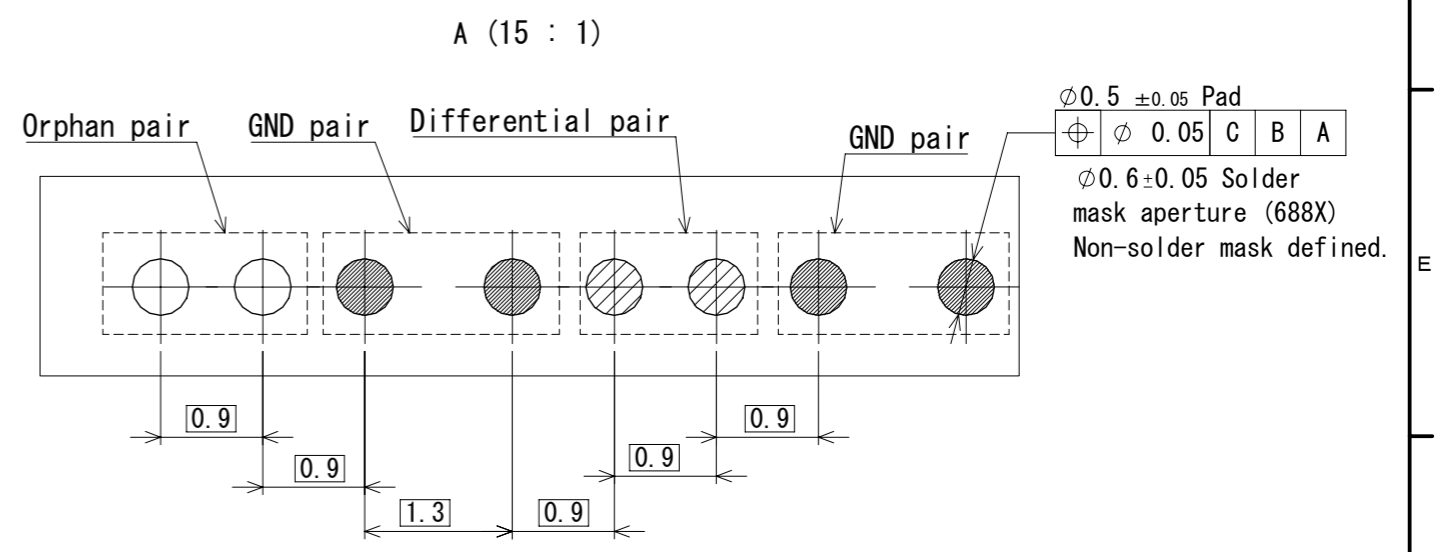

	UNITS mm	SCALE 2:1	COUNT 4	DESCRIPTION OF REVISIONS DIS-F-00013899	DESIGNED TH. SANO	CHECKED NH. TAMAI	DATE 2022.05.11
	APPROVED : TM. MATSUO      2021.08.02		DRAWING NO.      EDC-391549-00-00		PART NO.      IT14-688S-BGA-2.5H		CODE NO.      CL0636-6001-0-00
CHECKED : NH. TAMAI      2021.08.02		DESIGNED : TH. SANO      2021.07.30		DRAWN : TH. SANO      2021.07.30		<div style="display: flex; justify-content: space-between;"> <span>2</span> <span>3</span> </div>	

Jun.1.2023 Copyright 2023 HIROSE ELECTRIC CO., LTD. All Rights Reserved.  
 In case of consideration for using Automotive equipment / device which demand high reliability, kindly contact our sales window correspondents.

### Drawing for packaging

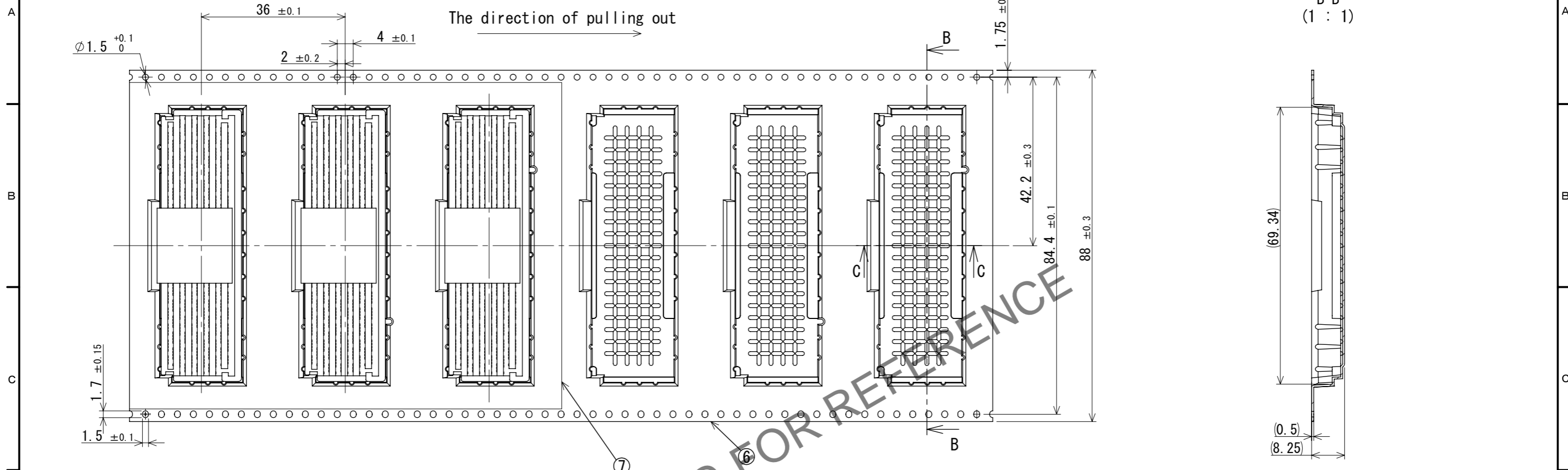

B-B  
(1 : 1)

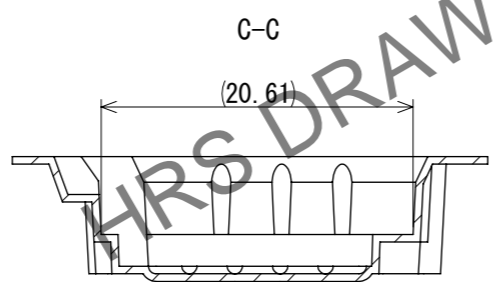

Detail of reel (Free)

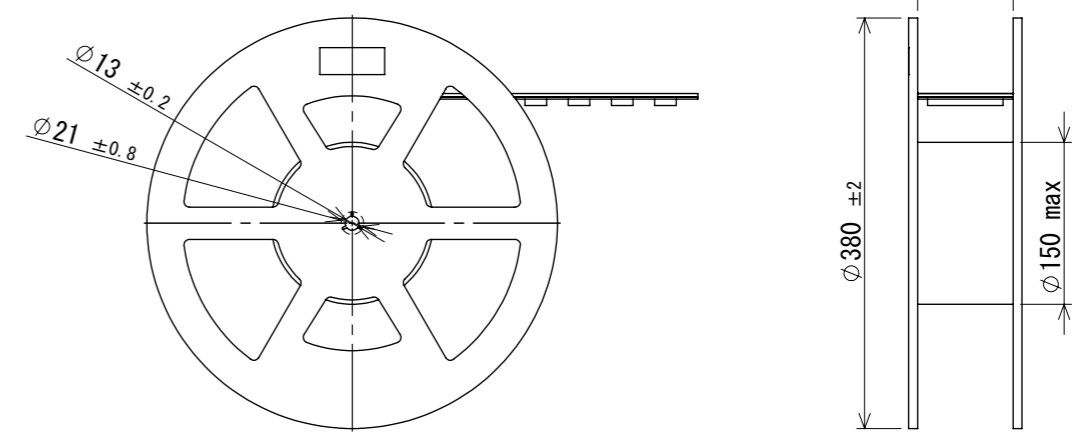

### Tape leader and trailer dimensions

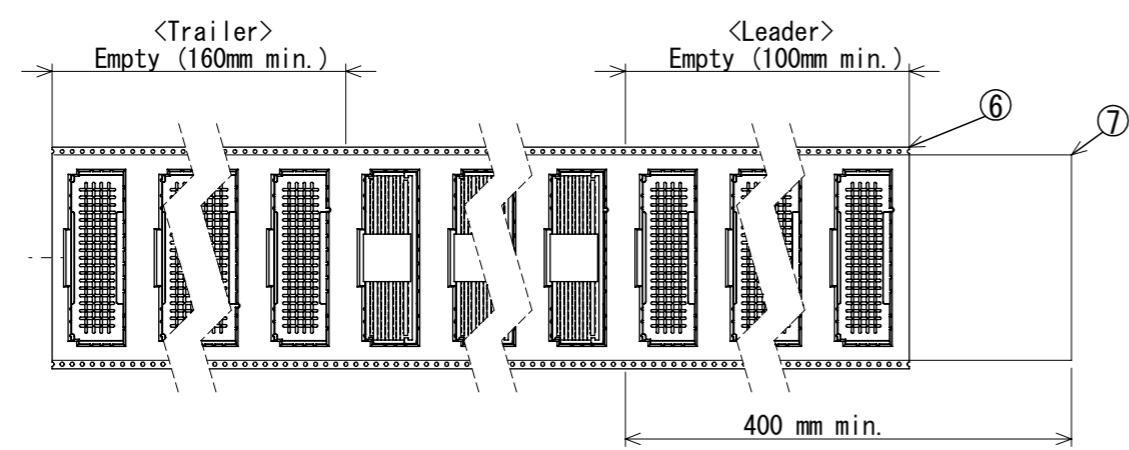

UNITS	SCALE	COUNT	DESCRIPTION OF REVISIONS	DESIGNED	CHECKED	DATE
mm	2:1	4	DIS-F-00013899	TH. SANO	NH. TAMAI	2022.05.11
APPROVED : TM. MATSUO			2021.08.02	DRAWING NO. EDC-391549-00-00		
CHECKED : NH. TAMAI			2021.08.02	PART NO. IT14-688S-BGA-2.5H		
DESIGNED : TH. SANO			2021.07.30	CODE NO. CL0636-6001-0-00		
DRAWN : TH. SANO			2021.07.30	3/3		



HIROSE ELECTRIC CO., LTD.