

## INA12x-HT Precision, Low-Power Instrumentation Amplifiers

### 1 Features

- Low Offset Voltage: 25  $\mu\text{V}$  Typical
- Low Input Bias Current: 50 nA Typical <sup>(1)</sup>
- High CMR: 95 dB Typical<sup>(1)</sup>
- Inputs Protected to  $\pm 40\text{ V}$
- Wide Supply Range:  $\pm 2.25\text{ V}$  to  $\pm 18\text{ V}$
- Low Quiescent Current: 2 mA Typical<sup>(1)</sup>

### 2 Applications

- Bridge Amplifiers
- Thermocouple Amplifiers
- RTD Sensor Amplifiers
- Medical Instrumentation
- Data Acquisition
- Supports Extreme Temperature Applications:
  - Controlled Baseline
  - One Assembly/Test Site
  - One Fabrication Site
  - Available in Extreme Temperature Ranges ( $-55^{\circ}\text{C}$  to  $210^{\circ}\text{C}$ ) <sup>(2)</sup>
  - Extended Product Life Cycle
  - Extended Product-Change Notification
  - Product Traceability

### 3 Description

The INA128-HT and INA129-HT are low-power, general-purpose instrumentation amplifiers offering excellent accuracy. The versatile three-operational-amplifier design and small size make them ideal for a wide range of applications. Current-feedback input circuitry provides wide bandwidth even at high gain. A single external resistor sets any gain from 1 to 10000. The INA128-HT provides an industry-standard gain equation; the INA129-HT gain equation is compatible with the AD620.

The INA128-HT and INA129-HT are laser trimmed for very low offset voltage (25  $\mu\text{V}$  Typ) and high common-mode rejection (93 dB at  $G \geq 100$ ). These devices operate with power supplies as low as  $\pm 2.25\text{ V}$ , and quiescent current of 2 mA, typically. Internal input protection can withstand up to  $\pm 40\text{ V}$  without damage.

Texas Instruments' high-temperature products use highly optimized silicon (die) solutions with design and process enhancements to maximize performance over extended temperatures.

The INA129-HT is available in 8-pin ceramic DIP and 8-pin ceramic surface-mount packages, specified for the  $-55^{\circ}\text{C}$  to  $210^{\circ}\text{C}$  temperature range. The INA128-HT is available in an 8-pin SOIC-8 surface-mount package, specified for the  $-55^{\circ}\text{C}$  to  $175^{\circ}\text{C}$  temperature range.

#### Device Information<sup>(1)</sup>

PART NUMBER	PACKAGE	BODY SIZE (NOM)
INA128-HT	SOIC (8)	4.90 mm x 3.91 mm
INA129-HT	CFP (8)	6.90 mm x 5.65 mm
	CDIP SB (8)	11.81 mm x 7.49 mm

- (1) Typical values for  $210^{\circ}\text{C}$  application.  
 (2) Custom temperature ranges available.

- (1) For all available packages, see the orderable addendum at the end of the data sheet.

### 4 Simplified Schematic

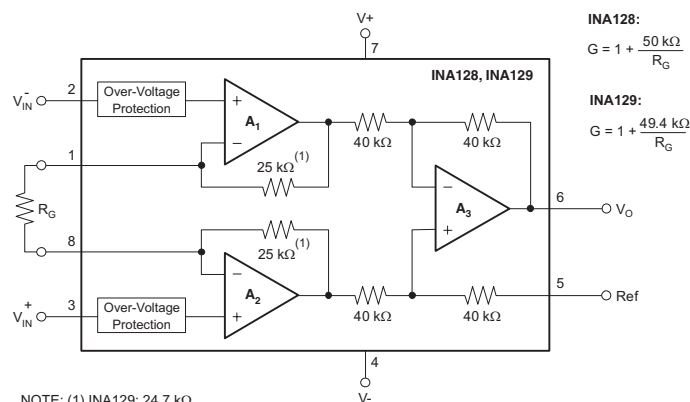

## Table of Contents

<b>1 Features</b> .....	<b>1</b>	8.3 Feature Description.....	<b>14</b>
<b>2 Applications</b> .....	<b>1</b>	8.4 Device Functional Modes.....	<b>15</b>
<b>3 Description</b> .....	<b>1</b>	<b>9 Application and Implementation</b> .....	<b>16</b>
<b>4 Simplified Schematic</b> .....	<b>1</b>	9.1 Application Information.....	<b>16</b>
<b>5 Revision History</b> .....	<b>2</b>	9.2 Typical Application .....	<b>16</b>
<b>6 Pin Configuration and Functions</b> .....	<b>3</b>	<b>10 Power Supply Recommendations</b> .....	<b>20</b>
<b>7 Specifications</b> .....	<b>5</b>	10.1 Low Voltage Operation .....	<b>20</b>
7.1 Absolute Maximum Ratings .....	<b>5</b>	<b>11 Layout</b> .....	<b>22</b>
7.2 ESD Ratings .....	<b>5</b>	11.1 Layout Guidelines .....	<b>22</b>
7.3 Recommended Operating Conditions.....	<b>5</b>	11.2 Layout Example .....	<b>22</b>
7.4 Thermal Information: INA128-HT.....	<b>5</b>	<b>12 Device and Documentation Support</b> .....	<b>23</b>
7.5 Electrical Characteristics: INA128-HT.....	<b>6</b>	12.1 Device Support.....	<b>23</b>
7.6 Electrical Characteristics: INA129-HT.....	<b>8</b>	12.2 Related Links .....	<b>23</b>
7.7 Typical Characteristics.....	<b>11</b>	12.3 Trademarks .....	<b>23</b>
<b>8 Detailed Description</b> .....	<b>14</b>	12.4 Electrostatic Discharge Caution.....	<b>23</b>
8.1 Overview .....	<b>14</b>	12.5 Glossary .....	<b>23</b>
8.2 Functional Block Diagram .....	<b>14</b>	<b>13 Mechanical, Packaging, and Orderable Information</b> .....	<b>23</b>

## 5 Revision History

### Changes from Revision E (July 2013) to Revision F

Page

- Added *ESD Ratings* table, *Feature Description* section, *Device Functional Modes*, *Application and Implementation* section, *Power Supply Recommendations* section, *Layout* section, *Device and Documentation Support* section, and *Mechanical, Packaging, and Orderable Information* section .....
- Deleted *Ordering Information* table; for all available packages, see the package option addendum .....

## 6 Pin Configuration and Functions

**D, HKJ, or JDJ Package**  
8-Pin SOIC, CFP, or CDIP SB  
Top View

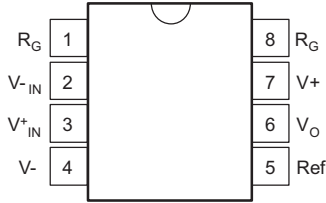

**HKQ Package**  
8-Pin CFP  
Top View

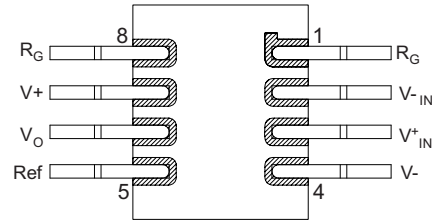

HKQ as formed or HKJ mounted dead bug

### Pin Functions

PIN		I/O	DESCRIPTION
NAME	NO.		
Ref	5	I	Output voltage reference
RG	1, 8	O	Gain resistor connection
V+	7	Power	Positive power supply voltage from 2.25 V to 18 V
V-	4	Power	Negative power supply voltage from -2.25 V to -18 V
V+IN	3	I	Non-inverting input voltage
V-IN	2	I	Inverting input voltage
VO	6	O	Output voltage

### Bare Die Information

DIE THICKNESS	BACKSIDE FINISH	BACKSIDE POTENTIAL	BOND PAD METALLIZATION COMPOSITION
15 mils	Silicon with backgrind	GND	Al-Si-Cu (0.5%)

Origin

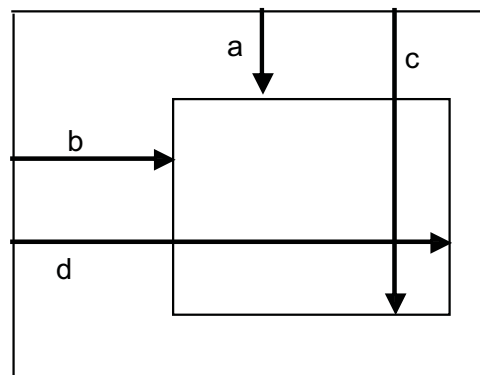

**INA128-HT, INA129-HT**

SBOS501F –JANUARY 2010–REVISED FEBRUARY 2015

www.ti.com

**Bond Pad Coordinates in Mils**

DESCRIPTION	PAD NUMBER	a	b	c	d
NC	1	-57.4	-31.1	-53.3	-27
V <sub>-IN</sub>	2	-9.85	-31.4	-5.75	-27.3
V <sub>+IN</sub>	3	25.05	-31.4	29.15	-27.3
V-	4	56.2	-34.3	60.3	-30.2
Ref	5	53.75	-17.6	57.85	-11
V <sub>O</sub>	6	50.35	27.8	56.95	31.9
V+	7	7.75	30.2	11.85	34.3
NC	8	-57.4	28.4	-53.3	32.5
R <sub>G</sub> <sup>(1)</sup>	9	-57.4	13.4	-53.3	20
R <sub>G</sub> <sup>(1)</sup>	10	-57.5	2.7	-53.4	9.3
R <sub>G</sub> <sup>(1)</sup>	11	-57.5	-7.9	-53.4	-1.3
R <sub>G</sub> <sup>(1)</sup>	12	-57.4	-18.6	-53.3	-12

(1) Pads 9 and 10 must both be bonded to a common point and correspond to package pin 8. Pads 11 and 12 must both be bonded to a common point and correspond to package pin 1.

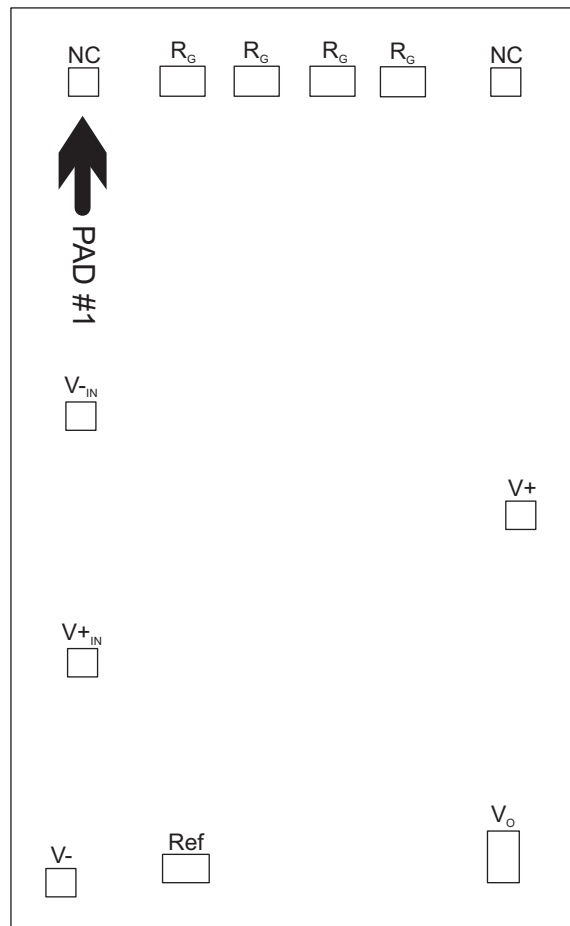

## 7 Specifications

### 7.1 Absolute Maximum Ratings

over operating free-air temperature range (unless otherwise noted) <sup>(1)</sup>

		MIN	MAX	UNIT
Voltage	Supply		±18	V
	Analog input		±40	
Current	Output short-circuit (to ground)	Continuous		
Operating temperature	HKJ, HKQ, KGD and JD packages	–55	210	°C
	D package	–55	175	
Storage temperature, T <sub>stg</sub>	HKJ, HKQ, KGD and JD packages	–55	210	°C
	D package	–55	175	

(1) Stresses beyond those listed under *Absolute Maximum Ratings* may cause permanent damage to the device. These are stress ratings only, which do not imply functional operation of the device at these or any other conditions beyond those indicated under *Recommended Operating Conditions*. Exposure to absolute-maximum-rated conditions for extended periods may affect device reliability.

### 7.2 ESD Ratings

		VALUE	UNIT
<b>A. INA218-HT (D, HKJ, or JDJ Package)</b>			
V <sub>(ESD)</sub> Electrostatic discharge	Human-body model (HBM), per ANSI/ESDA/JEDEC JS-001 <sup>(1)</sup>	±2000	V
	Charged-device model (CDM), per JEDEC specification JESD22-C101 <sup>(2)</sup>	±50	
<b>B. INA129-HT (HKQ Package)</b>			
V <sub>(ESD)</sub> Electrostatic discharge	Human-body model (HBM), per ANSI/ESDA/JEDEC JS-001 <sup>(1)</sup>	±4000	V
	Charged-device model (CDM), per JEDEC specification JESD22-C101 <sup>(2)</sup>	±200	

(1) JEDEC document JEP155 states that 500-V HBM allows safe manufacturing with a standard ESD control process.

(2) JEDEC document JEP157 states that 250-V CDM allows safe manufacturing with a standard ESD control process.

### 7.3 Recommended Operating Conditions

over operating free-air temperature range (unless otherwise noted)

	MIN	NOM	MAX	UNIT
V power supply	±2.25	±15	±18	V
Input common-mode voltage range for V <sub>O</sub> = 0	V – 2 V		V + –2 V	
T <sub>A</sub> operating temperature INA128-HT	–55		175	°C
T <sub>A</sub> operating temperature INA129-HT	–55		210	°C

### 7.4 Thermal Information: INA128-HT

THERMAL METRIC <sup>(1)</sup>		INA128-HT	UNIT
		D [SOIC]	
		8 PINS	
R <sub>θJA</sub>	Junction-to-ambient thermal resistance	110	°C/W
R <sub>θJC(top)</sub>	Junction-to-case (top) thermal resistance	57	
R <sub>θJB</sub>	Junction-to-board thermal resistance	54	
ψ <sub>JT</sub>	Junction-to-top characterization parameter	11	
ψ <sub>JB</sub>	Junction-to-board characterization parameter	53	

(1) For more information about traditional and new thermal metrics, see the *IC Package Thermal Metrics* application report, [SPRA953](#).

# INA128-HT, INA129-HT

SBOS501F – JANUARY 2010 – REVISED FEBRUARY 2015

www.ti.com

## 7.5 Electrical Characteristics: INA128-HT

over operating free-air temperature range (unless otherwise noted)

PARAMETER	TEST CONDITIONS	$T_A = -55^\circ\text{C to } +125^\circ\text{C}$			$T_A = 175^\circ\text{C}^{(1)}$			UNIT
		MIN	TYP	MAX	MIN	TYP	MAX	
<b>INPUT</b>								
<b>OFFSET VOLTAGE, RTI</b>								
Initial	$T_A = 25^\circ\text{C}$		$\pm 25$ $\pm 100/\text{G}$	$\pm 125$ $\pm 1000/\text{G}$				$\mu\text{V}$
vs temperature	$T_A = T_{\text{MIN}} \text{ to } T_{\text{MAX}}$		$\pm 0.2$ $\pm 5/\text{G}$	$\pm 1$ $\pm 20/\text{G}$			$\pm 3.5$ $\pm 80/\text{G}$	$\mu\text{V}/^\circ\text{C}$
vs power supply	$V_S = \pm 2.25 \text{ V to } \pm 18 \text{ V}$			$\pm 2$ $\pm 200/\text{G}$			$\pm 5$ $\pm 500/\text{G}$	$\mu\text{V}/\text{V}$
Long-term stability			$\pm 1 \pm 3/\text{G}$			$\pm 1 \pm 3/\text{G}$		$\mu\text{V}/\text{mo}$
Impedance, differential			$10^{10} \parallel 2$			$10^{10} \parallel 2$		$\Omega \parallel \text{pF}$
Common mode			$10^{11} \parallel 9$			$10^{11} \parallel 9$		$\Omega \parallel \text{pF}$
Common mode voltage range <sup>(2)</sup>	$V_O = 0 \text{ V}$	$(V+) - 2$	$(V+) - 1.4$		$(V+) - 2$	$(V+) - 1.4$		V
		$(V-) + 2$	$(V-) + 1.7$		$(V-) + 2$	$(V-) + 1.7$		V
Safe input voltage				$\pm 40$			$\pm 40$	V
Common-mode rejection	$V_{\text{CM}} = \pm 13 \text{ V},$ $\Delta R_S = 1 \text{ k}\Omega$							dB
	G = 1	58	86		58	75		
	G = 10	78	106		78	85		
	G = 100	99	125		99	110		
	G = 1000	113	130		113	120		
<b>CURRENT</b>								
Bias current			$\pm 2$	$\pm 10$			$\pm 45$	nA
vs temperature			$\pm 30$			$\pm 550$		$\text{pA}/^\circ\text{C}$
Offset Current			$\pm 1$	$\pm 10$			$\pm 45$	nA
vs temperature			$\pm 30$			$\pm 550$		$\text{pA}/^\circ\text{C}$
<b>NOISE</b>								
Noise voltage, RTI	G = 1000, $R_S = 0 \Omega$							
f = 10 Hz			10			10		$\text{nV}/\sqrt{\text{Hz}}$
f = 100 Hz			8			8		$\text{nV}/\sqrt{\text{Hz}}$
f = 1 kHz			8			8		$\text{nV}/\sqrt{\text{Hz}}$
$f_B = 0.1 \text{ Hz to } 10 \text{ Hz}$			0.2			0.8		$\mu\text{V}_{\text{PP}}$
Noise current								
f = 10 Hz			0.9					$\text{pA}/\sqrt{\text{Hz}}$
f = 1 kHz			0.3					$\text{pA}/\sqrt{\text{Hz}}$
$f_B = 0.1 \text{ Hz to } 10 \text{ Hz}$			30					$\text{pA}_{\text{PP}}$

- (1) Minimum and maximum parameters are characterized for operation at  $T_A = 175^\circ\text{C}$ , but may not be production tested at that temperature. Production test limits with statistical guardbands are used to ensure high temperature performance.
- (2) Input common-mode range varies with output voltage — see typical curves.

**Electrical Characteristics: INA128-HT (continued)**

over operating free-air temperature range (unless otherwise noted)

PARAMETER	TEST CONDITIONS	T <sub>A</sub> = -55°C to +125°C			T <sub>A</sub> = 175°C <sup>(1)</sup>			UNIT	
		MIN	TYP	MAX	MIN	TYP	MAX		
<b>GAIN</b>									
Gain equation		1 + (50 kΩ/R <sub>G</sub> )			1 + (50 kΩ/R <sub>G</sub> )			V/V	
Range of gain		1		10000	1		10000	V/V	
Gain error	G = 1		±0.01	±0.1		±0.1%	±0.5%		
	G = 10		±0.02	±0.5		±0.5%	±1%		
	G = 100		±0.05	±0.7		±0.7%	±1.5%		
	G = 1000		±0.5	±2.5		±2%	±4%		
Gain vs temperature <sup>(3)</sup>	G = 1		±1	±10		±75		ppm/°C	
50-kΩ resistance <sup>(3)(4)</sup>			±25	±100		±75		ppm/°C	
Nonlinearity	V <sub>O</sub> = ±13.6 V, G = 1		±0.0001	±0.001			±0.008	% of FSR	
	G = 10		±0.0003	±0.002			±0.01		
	G = 100		±0.0005	±0.002			±0.01		
	G = 1000		±0.001	See <sup>(5)</sup>		±0.6	See <sup>(5)</sup>		
<b>OUTPUT</b>									
Voltage	Positive	R <sub>L</sub> = 10 kΩ	(V+) - 1.4	(V+) - 0.9	(V+) - 1.4	(V+) - 0.9		V	
	Negative	R <sub>L</sub> = 10 kΩ	(V-) + 1.4	(V-) + 0.8	(V-) + 1.4	(V-) + 0.8			
Load capacitance stability				1000		1000		pF	
Short-circuit current				+6/-15		+6/-15		mA	
<b>FREQUENCY RESPONSE</b>									
Bandwidth, -3 dB	G = 1			1300			1100	kHz	
	G = 10			700			700		
	G = 100			200			190		
	G = 1000			20			17.5		
Slew rate	V <sub>O</sub> = ±10 V, G = 10			4			4	V/μs	
Settling time, 0.01%	G = 1			7			7	μs	
	G = 10			7			7		
	G = 100			9			9		
	G = 1000			80			80		
Overload recovery	50% overdrive			4			4	μs	
<b>POWER SUPPLY</b>									
Voltage range			±2.25	±15	±18	±2.25	±15	±18	V
Current, total	V <sub>IN</sub> = 0 V			±0.7	±1			±1	mA
<b>TEMPERATURE RANGE</b>									
Specification				-55				175	°C
Operating				-55				175	°C

(3) Specified by wafer test.

(4) Temperature coefficient of the 50-kΩ term in the gain equation.

(5) Nonlinearity measurements in G = 1000 are dominated by noise. Typical nonlinearity is ±0.001%.

## 7.6 Electrical Characteristics: INA129-HT

over operating free-air temperature range (unless otherwise noted)

PARAMETER	TEST CONDITIONS	$T_A = -55^\circ\text{C to } +125^\circ\text{C}$			$T_A = 210^\circ\text{C}^{(1)}$			UNIT
		MIN	TYP	MAX	MIN	TYP	MAX	
<b>INPUT</b>								
<b>OFFSET VOLTAGE, RTI</b>								
Initial	$T_A = 25^\circ\text{C}$		$\pm 25$ $\pm 100/\text{G}$	$\pm 125$ $\pm 1000/\text{G}$				$\mu\text{V}$
vs temperature	$T_A = T_{\text{MIN}}$ to $T_{\text{MAX}}$		$\pm 0.2$ $\pm 5/\text{G}$	$\pm 1$ $\pm 20/\text{G}$		$\pm 1$ $\pm 850/\text{G}$		$\mu\text{V}/^\circ\text{C}$
vs power supply	$V_S = \pm 2.25\text{ V to } \pm 18\text{ V}$		$\pm 0.2$ $\pm 20/\text{G}$	$\pm 2$ $\pm 200/\text{G}$		$\pm 20$ $\pm 1000/\text{G}$		$\mu\text{V}/\text{V}$
Long-term stability			$\pm 1$ $\pm 3/\text{G}$			$\pm 1$ $\pm 3/\text{G}$		$\mu\text{V}/\text{mo}$
Impedance, differential			$10^{10} \parallel 2$			$10^{10} \parallel 2$		$\Omega \parallel \text{pF}$
Common mode			$10^{11} \parallel 9$			$10^{11} \parallel 9$		$\Omega \parallel \text{pF}$
Common mode voltage range <sup>(2)</sup>	$V_O = 0\text{ V}$	$(V+) - 2$	$(V+) - 1.4$		$(V+) - 2$	$(V+) - 1.4$		V
		$(V-) + 2$	$(V-) + 1.7$		$(V-) + 2$	$(V-) + 1.7$		V
Safe input voltage				$\pm 40$		$\pm 40$		V
Common-mode rejection	$V_{\text{CM}} = \pm 13\text{ V,}$ $\Delta R_S = 1\text{ k}\Omega$							dB
	G = 1	58	86		53			
	G = 10	78	106		69			
	G = 100	99	125		89			
	G = 1000	113	130		95			
<b>CURRENT</b>								
Bias current			$\pm 2$	$\pm 10$		$\pm 50$		nA
vs temperature			$\pm 30$			$\pm 600$		$\text{pA}/^\circ\text{C}$
Offset Current			$\pm 1$	$\pm 10$		$\pm 50$		nA
vs temperature			$\pm 30$			$\pm 600$		$\text{pA}/^\circ\text{C}$
<b>NOISE</b>								
Noise voltage, RTI	G = 1000, $R_S = 0\ \Omega$							
f = 10 Hz			10			25		$\text{nV}/\sqrt{\text{Hz}}$
f = 100 Hz			8			20		$\text{nV}/\sqrt{\text{Hz}}$
f = 1 kHz			8			20		$\text{nV}/\sqrt{\text{Hz}}$
$f_B = 0.1\text{ Hz to } 10\text{ Hz}$			0.2			2		$\mu\text{V}_{\text{PP}}$
Noise current								
f = 10 Hz			0.9					$\text{pA}/\sqrt{\text{Hz}}$
f = 1 kHz			0.3					$\text{pA}/\sqrt{\text{Hz}}$
$f_B = 0.1\text{ Hz to } 10\text{ Hz}$			30					$\text{pA}_{\text{PP}}$

- (1) Minimum and maximum parameters are characterized for operation at  $T_A = 210^\circ\text{C}$ , but may not be production tested at that temperature. Production test limits with statistical guardbands are used to ensure high temperature performance.
- (2) Input common-mode range varies with output voltage — see typical curves.

**Electrical Characteristics: INA129-HT (continued)**

over operating free-air temperature range (unless otherwise noted)

PARAMETER	TEST CONDITIONS	T <sub>A</sub> = -55°C to +125°C			T <sub>A</sub> = 210°C <sup>(1)</sup>			UNIT	
		MIN	TYP	MAX	MIN	TYP	MAX		
<b>GAIN</b>									
Gain equation		$1 + (49.4 \text{ k}\Omega/R_G)$			$1 + (49.4 \text{ k}\Omega/R_G)$			V/V	
Range of gain		1		10000	1		10000	V/V	
Gain error	G = 1		±0.01%	±0.1%		±1.1%			
	G = 10		±0.02%	±0.5%		±2.6%			
	G = 100		±0.05%	±0.7%		±13.5%			
	G = 1000		±0.5%	±2.5%		±65.5%			
Gain vs temperature <sup>(3)</sup>	G = 1		±1	±10		±100		ppm/°C	
49.4-kΩ resistance <sup>(3)(4)</sup>			±25	±100		±100		ppm/°C	
Nonlinearity	V <sub>O</sub> = ±13.6 V, G = 1		±0.0001	±0.001		±0.1		% of FSR	
	G = 10		±0.0003	±0.002		±0.2			
	G = 100		±0.0005	±0.002		±0.7			
	G = 1000		±0.001	See <sup>(5)</sup>		±2.4	See <sup>(5)</sup>		
<b>OUTPUT</b>									
Voltage	Positive	R <sub>L</sub> = 10kΩ	(V+) - 1.4	(V+) - 0.9	(V+) - 1.4	(V+) - 0.9		V	
	Negative	R <sub>L</sub> = 10kΩ	(V-) + 1.4	(V-) + 0.8	(V-) + 1.4	(V-) + 0.8			
Load capacitance stability				1000		1000		pF	
Short-circuit current				+6/-15		+12/-5		mA	
<b>FREQUENCY RESPONSE</b>									
Bandwidth, -3 dB	G = 1			1300		850		kHz	
	G = 10			700		400			
	G = 100			200		50			
	G = 1000			20		7.5			
Slew rate	V <sub>O</sub> = ±10 V, G = 10			4		4		V/μs	
Settling time, 0.01%	G = 1			7		10		μs	
	G = 10			7		10			
	G = 100			9		30			
	G = 1000			80		150			
Overload recovery	50% overdrive			4		4		μs	
<b>POWER SUPPLY</b>									
Voltage range			±2.25	±15	±18	±2.25	±15	±18	V
Current, total	V <sub>IN</sub> = 0 V			±0.7	±1		±2		mA
<b>TEMPERATURE RANGE</b>									
Specification			-55		+125			210	°C
Operating			-55		+125			210	°C

(3) Specified by wafer test.

(4) Temperature coefficient of the 49.4-kΩ term in the gain equation.

(5) Nonlinearity measurements in G = 1000 are dominated by noise. Typical nonlinearity is ±0.001%.

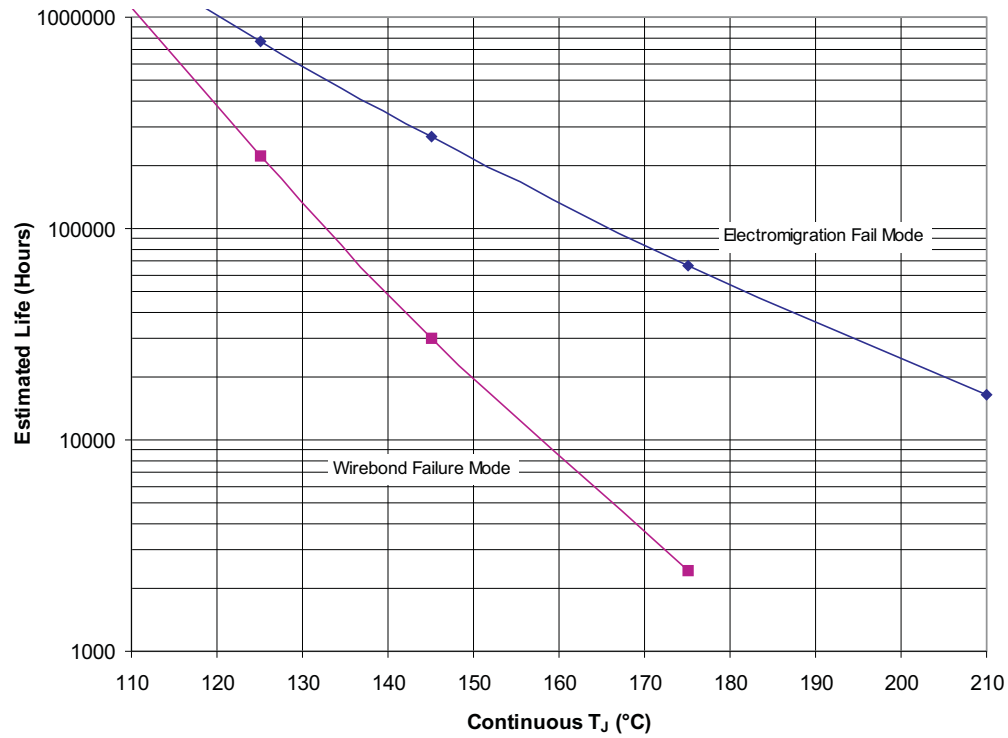

- (1) See the data sheet for absolute maximum and minimum recommended operating conditions.
- (2) The predicted operating lifetime vs. junction temperature is based on reliability modeling using electromigration as the dominant failure mechanism affecting device wearout for the specific device process and design characteristics.
- (3) Wirebond lifetime is only applicable for D package.

**Figure 1. INA128HD, INA129SKGD1, and INA129SKGD2 Operating Life Derating Chart**

### 7.7 Typical Characteristics

At  $T_A = 25^\circ\text{C}$ ,  $V_S = \pm 15\text{ V}$ , unless otherwise noted.

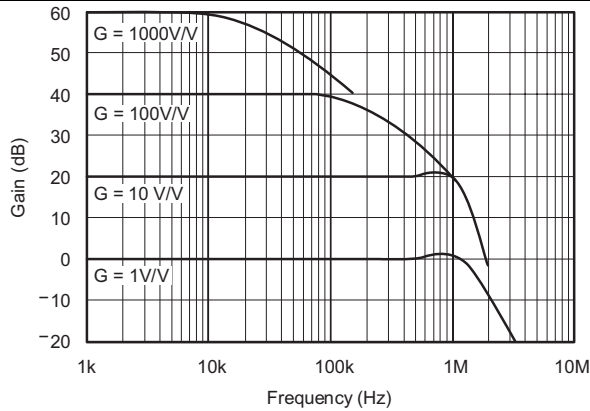

Figure 2. Gain vs Frequency

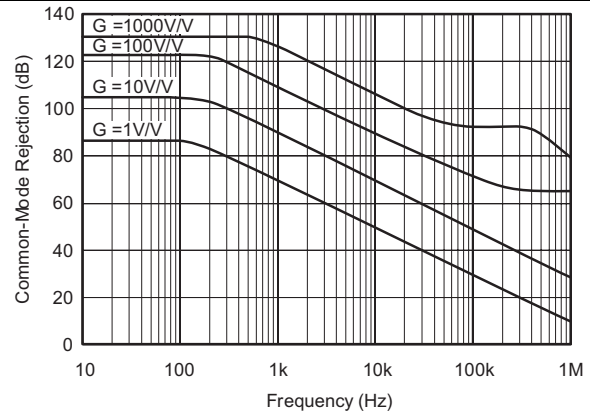

Figure 3. Common-Mode Rejection vs Frequency

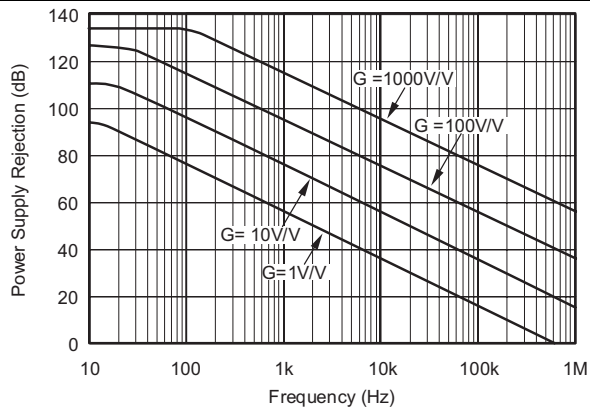

Figure 4. Positive Power-Supply Rejection vs Frequency

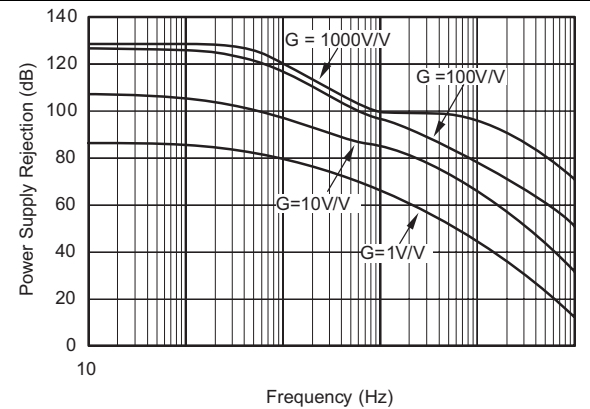

Figure 5. Negative Power-Supply Rejection vs Frequency

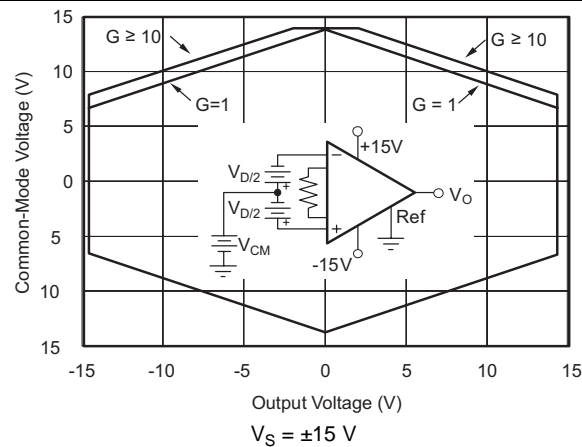

Figure 6. Input Common-Mode Range vs Output Voltage

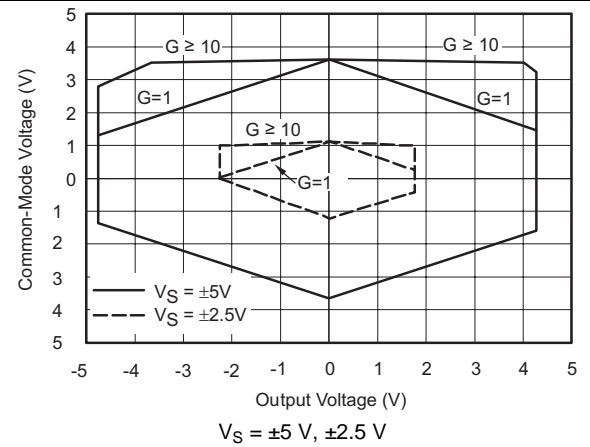

Figure 7. Input Common-Mode Range vs Output Voltage

Typical Characteristics (continued)

At  $T_A = 25^\circ\text{C}$ ,  $V_S = \pm 15\text{ V}$ , unless otherwise noted.

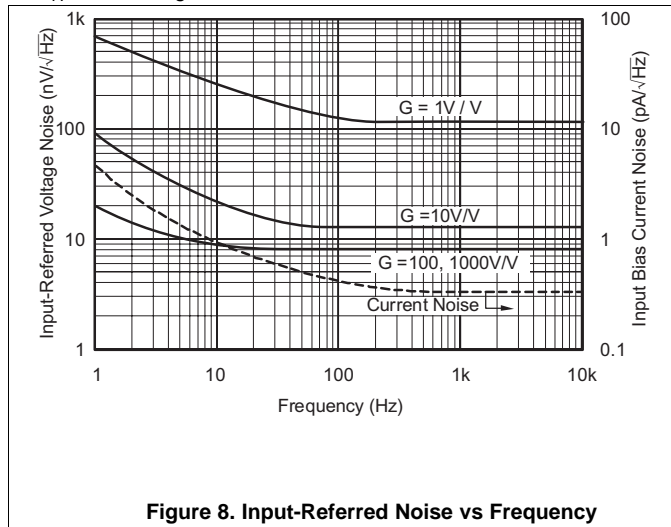

Figure 8. Input-Referred Noise vs Frequency

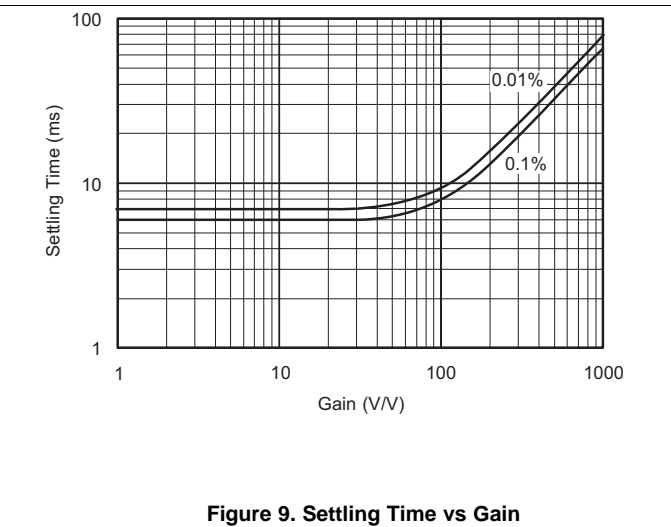

Figure 9. Settling Time vs Gain

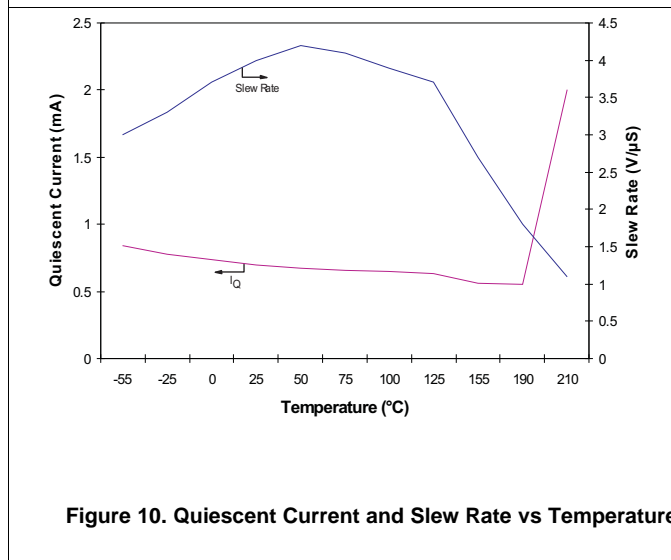

Figure 10. Quiescent Current and Slew Rate vs Temperature

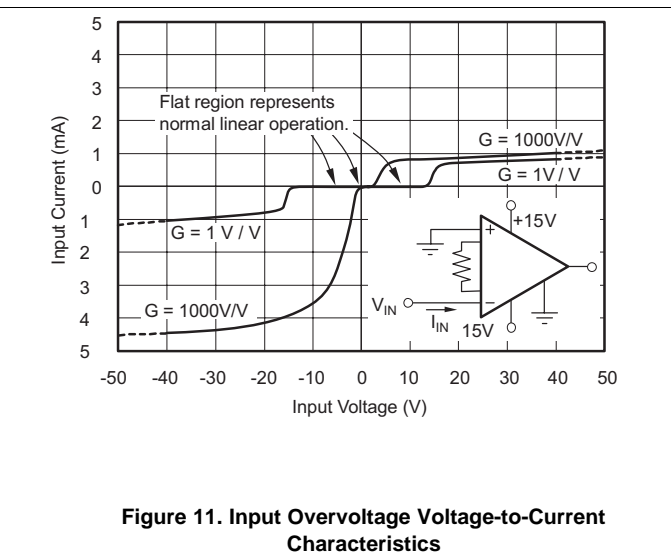

Figure 11. Input Overvoltage Voltage-to-Current Characteristics

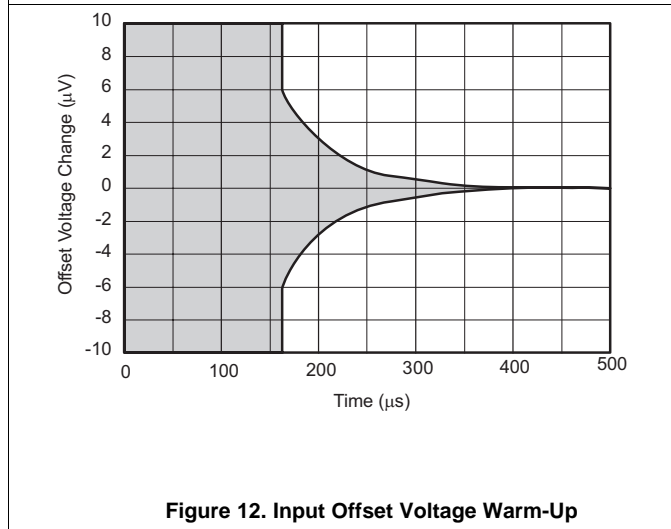

Figure 12. Input Offset Voltage Warm-Up

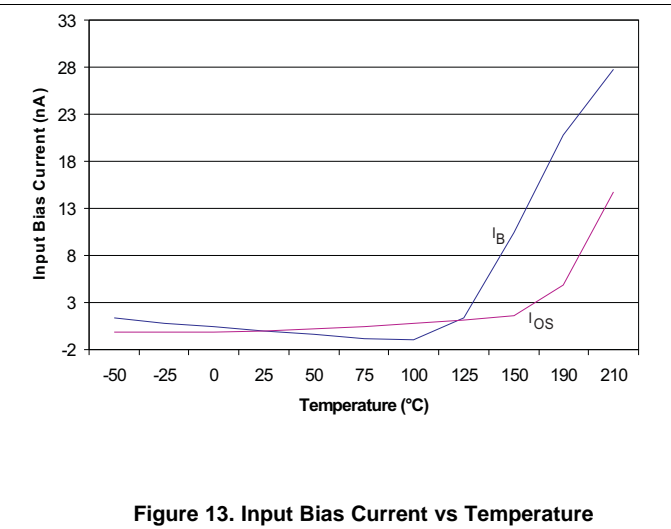

Figure 13. Input Bias Current vs Temperature

Typical Characteristics (continued)

At  $T_A = 25^\circ\text{C}$ ,  $V_S = \pm 15\text{ V}$ , unless otherwise noted.

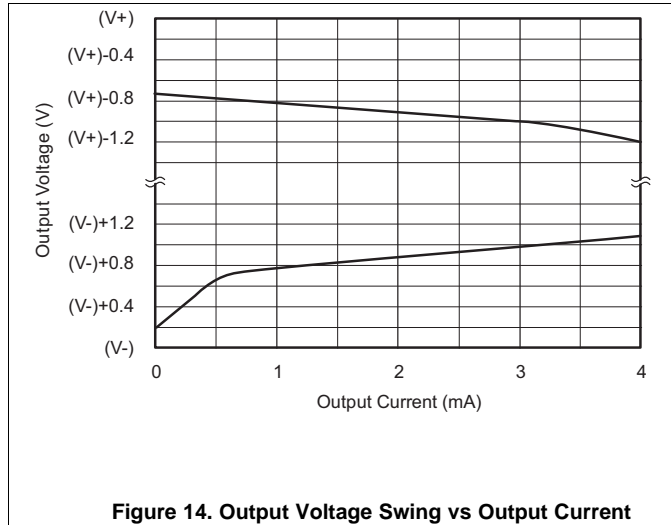

Figure 14. Output Voltage Swing vs Output Current

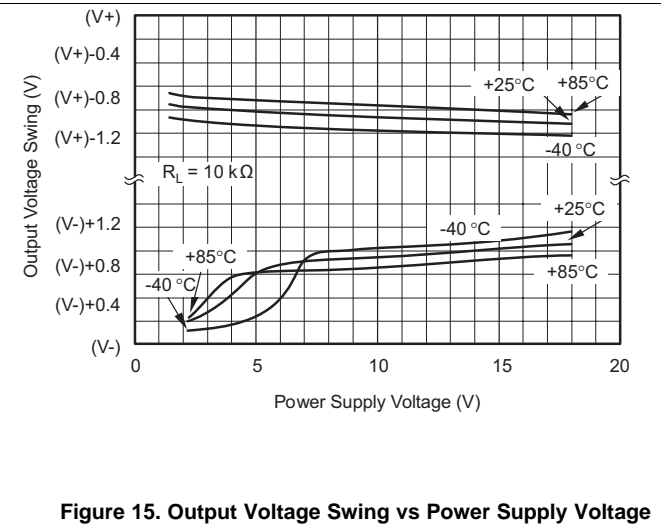

Figure 15. Output Voltage Swing vs Power Supply Voltage

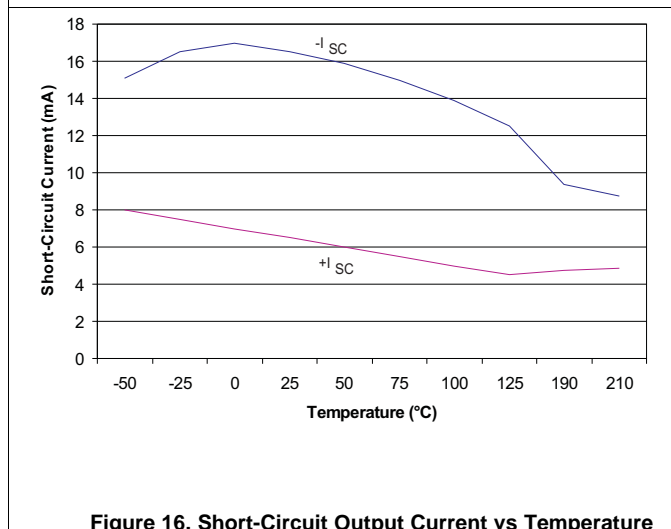

Figure 16. Short-Circuit Output Current vs Temperature

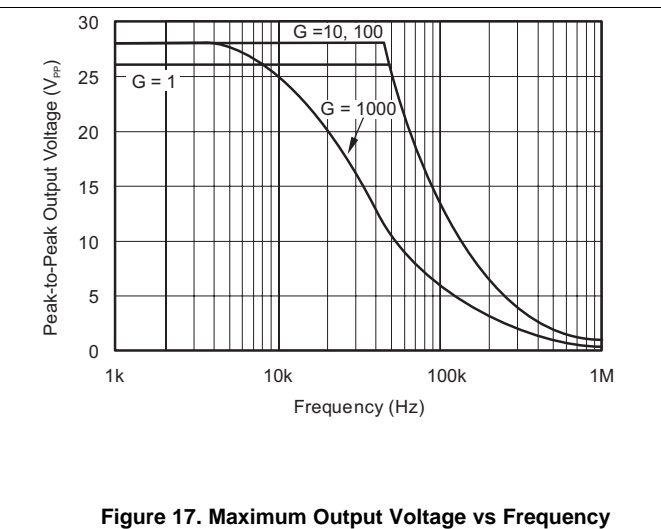

Figure 17. Maximum Output Voltage vs Frequency

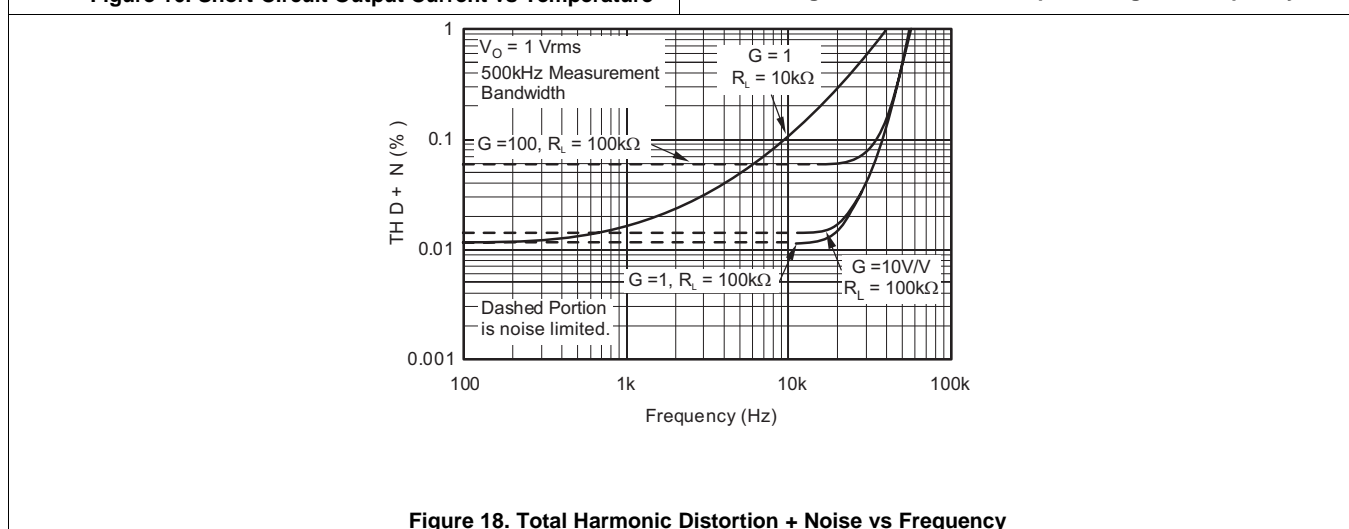

Figure 18. Total Harmonic Distortion + Noise vs Frequency

## 8 Detailed Description

### 8.1 Overview

The INA12x instrumentation amplifier is a type of differential amplifier that has been outfitted with input protection circuit and input buffer amplifiers, which eliminate the need for input impedance matching and make the amplifier particularly suitable for use in measurement and test equipment. Additional characteristics of the INA12x include a very low DC offset, low drift, low noise, very high open-loop gain, very high common-mode rejection ratio, and very high input impedances. The INA12x is used where great accuracy and stability of the circuit both short and long term are required.

### 8.2 Functional Block Diagram

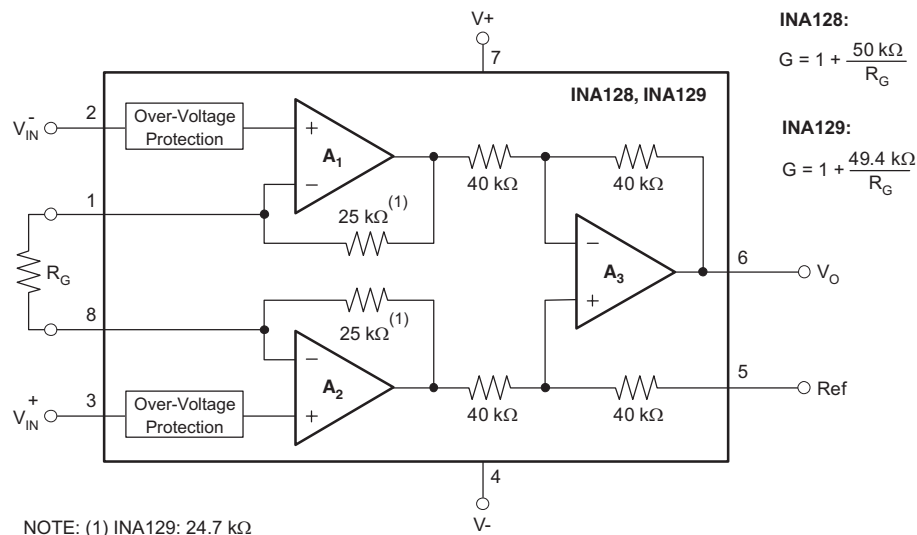

### 8.3 Feature Description

The INA128-HT and INA129-HT are low power, general-purpose instrumentation amplifiers offering excellent accuracy. The versatile three-operational-amplifier design and small size make the amplifiers ideal for a wide range of applications. Current-feedback input circuitry provides wide bandwidth, even at high gain. A single external resistor sets any gain from 1 to 10,000. The INA128-HT and INA129-HT are laser trimmed for very low offset voltage (25  $\mu\text{V}$  typical) and high common-mode rejection (93 dB at  $G \geq 100$ ). These devices operate with power supplies as low as  $\pm 2.25$  V, and quiescent current of 2 mA, typically. The internal input protection can withstand up to  $\pm 40$  V without damage.

## 8.4 Device Functional Modes

### 8.4.1 Noise Performance

The INA128-HT and INA129-HT provide very low noise in most applications. Low-frequency noise is approximately 2  $\mu$ VPP measured from 0.1 Hz to 10 Hz ( $G \geq 100$ ). This provides dramatically improved noise when compared to state-of-the-art, chopper-stabilized amplifiers.

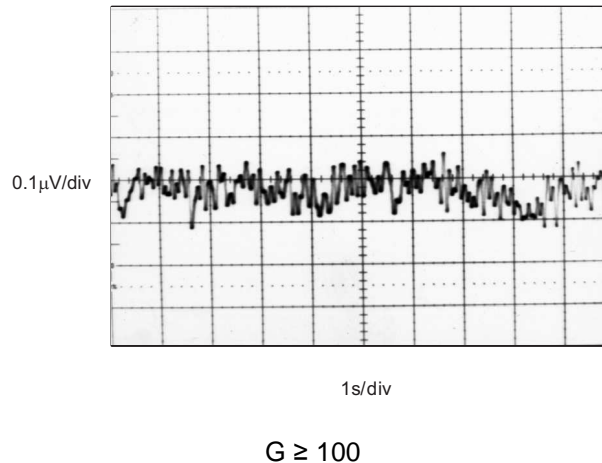

**Figure 19. 0.1-Hz to 10-Hz Input-Referred Voltage Noise**

### 8.4.2 Input Common-Mode Range

The linear input voltage ranges of the input circuitry of the INA128-HT and INA129-HT are from approximately 1.4 V below the positive supply voltage to 1.7 V above the negative supply. As a differential input voltage causes the output voltage increase, however, the linear input range will be limited by the output voltage swing of amplifiers A1 and A2. So the linear common-mode input range is related to the output voltage of the complete amplifier. This behavior also depends on supply voltage (see [Figure 6](#) and [Figure 7](#)).

Input-overload can produce an output voltage that appears normal. For example, if an input overload condition drives both input amplifiers to their positive output swing limit, the difference voltage measured by the output amplifier will be near zero. The output of A3 will be near 0 V even though both inputs are overloaded.

## 9 Application and Implementation

### NOTE

Information in the following applications sections is not part of the TI component specification, and TI does not warrant its accuracy or completeness. TI's customers are responsible for determining suitability of components for their purposes. Customers should validate and test their design implementation to confirm system functionality.

### 9.1 Application Information

The INA12x measures small differential voltage with high common-mode voltage developed between the non-inverting and inverting input. The high-input voltage protection circuit in conjunction with high input impedance make the INA12x suitable for a wide range of applications. The ability to set the reference pin to adjust the functionality of the output signal offers additional flexibility that is practical for multiple configurations.

### 9.2 Typical Application

Figure 20 shows the basic connections required for operation of the INA128-HT and INA129-HT. Applications with noisy or high impedance power supplies may require decoupling capacitors close to the device pins as shown.

The output is referred to the output reference (Ref) pin that is normally grounded. This must be a low-impedance connection to assure good common-mode rejection. A resistance of 8 Ω in series with the Ref pin will cause a typical device to degrade.

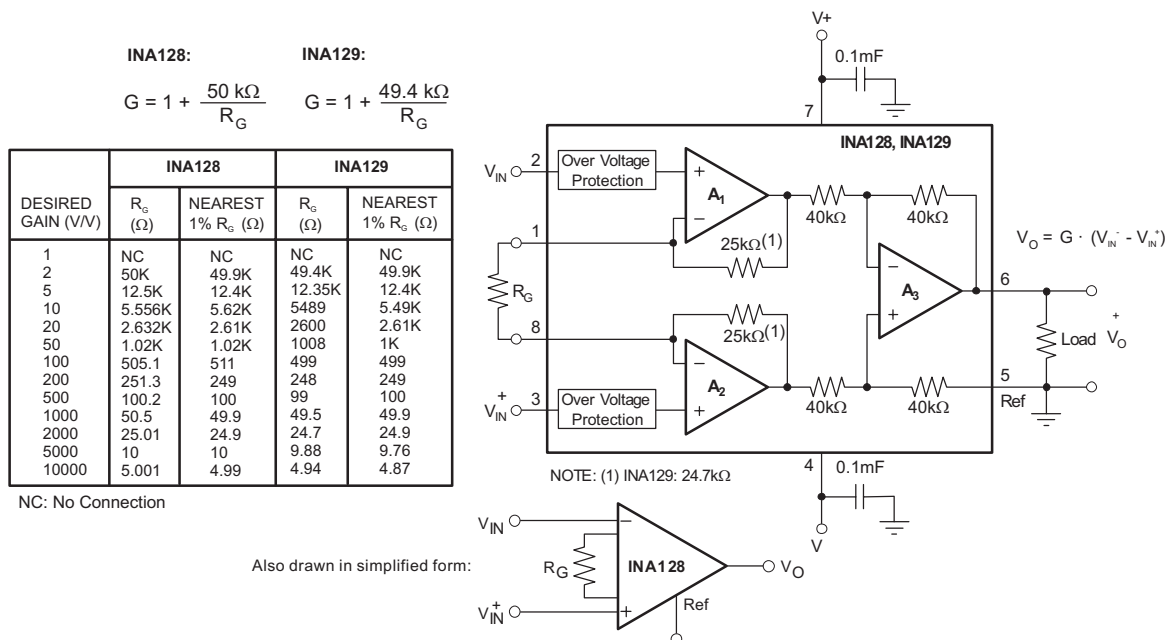

**Figure 20. Basic Connections**

#### 9.2.1 Design Requirements

The device can be configured to monitor the input differential voltage when the gain of the input signal is set by the external resistor R<sub>G</sub>. The output signal references to the Ref pin. The most common application is where the output is referenced to ground when no input signal is present by connecting the Ref pin to ground, as Figure 20 shows. When the input signal increases, the output voltage at the OUT pin increases, too.

## Typical Application (continued)

### 9.2.2 Detailed Design Procedure

#### 9.2.2.1 Setting the Gain

Gain is set by connecting a single external resistor,  $R_G$ , between pins 1 and 8.

INA128-HT:

$$G = 1 + \frac{50 \text{ k}\Omega}{R_G} \quad (1)$$

INA129-HT:

$$G = 1 + \frac{49.4 \text{ k}\Omega}{R_G} \quad (2)$$

Commonly used gains and resistor values are shown in [Figure 20](#).

The 50-k $\Omega$  term in [Equation 1](#) (49.4-k $\Omega$  in [Equation 2](#)) comes from the sum of the two internal feedback resistors of A1 and A2. These on-chip metal film resistors are laser trimmed to accurate absolute values. The accuracy and temperature coefficient of these internal resistors are included in the gain accuracy and drift specifications of the INA128-HT and INA129-HT.

The stability and temperature drift of the external gain setting resistor,  $R_G$ , also affects gain. The  $R_G$  contribution to gain accuracy and drift can be directly inferred from [Equation 2](#). Low resistor values required for high gain can make wiring resistance important. Sockets add to the wiring resistance which will contribute additional gain error (possibly an unstable gain error) in gains of approximately 100 or greater.

#### 9.2.2.2 Dynamic Performance

[Figure 2](#) shows that, despite its low quiescent current, the INA128-HT and INA129-HT achieve wide bandwidth, even at high gain. This is due to the current-feedback topology of the input stage circuitry. Settling time also remains excellent at high gain.

#### 9.2.2.3 Offset Trimming

The INA128-HT and INA129-HT are laser trimmed for low offset voltage and offset voltage drift. Most applications require no external offset adjustment. [Figure 21](#) shows an optional circuit for trimming the output offset voltage. The voltage applied to Ref terminal is summed with the output. The operational amplifier buffer provides low impedance at the Ref terminal to preserve good common-mode rejection.

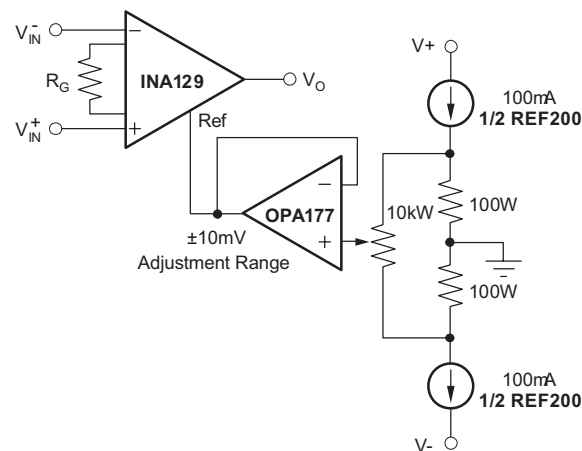

(1) [OPA177](#) and [REF200](#) are not tested or characterized at 210°C.

**Figure 21. Optional Trimming of Output Offset Voltage**

## Typical Application (continued)

### 9.2.2.4 Input Bias Current Return Path

The input impedances of the INA128-HT and INA129-HT are extremely high (approximately  $10^{10} \Omega$ ). However, a path must be provided for the input bias current of both inputs. This input bias current is approximately  $\pm 50 \text{ nA}$ . High input impedance means that this input bias current changes very little with varying input voltage.

Input circuitry must provide a path for this input bias current for proper operation. [Figure 22](#) shows various provisions for an input bias current path. Without a bias current path, the inputs will float to a potential which exceeds the common-mode range, and the input amplifiers will saturate.

If the differential source resistance is low, the bias current return path can be connected to one input (see the thermocouple example in [Figure 22](#)). With higher source impedance, using two equal resistors provides a balanced input with possible advantages of lower input offset voltage due to bias current and better high-frequency common-mode rejection.

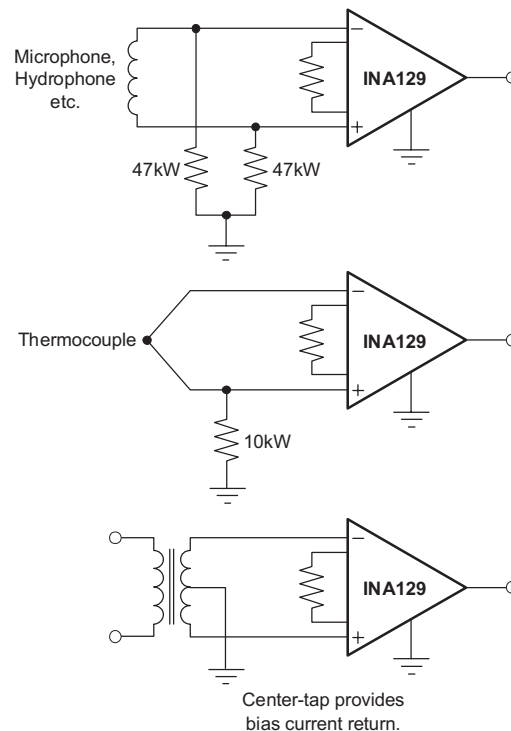

**Figure 22. Providing an Input Common-Mode Current Path**

Typical Application (continued)

9.2.3 Application Curves

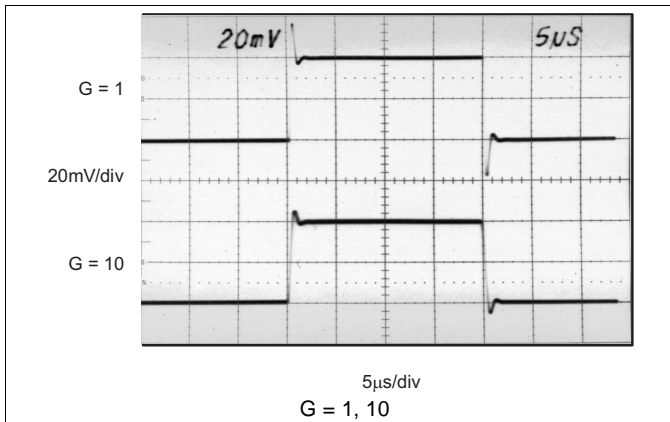

Figure 23. Small Signal

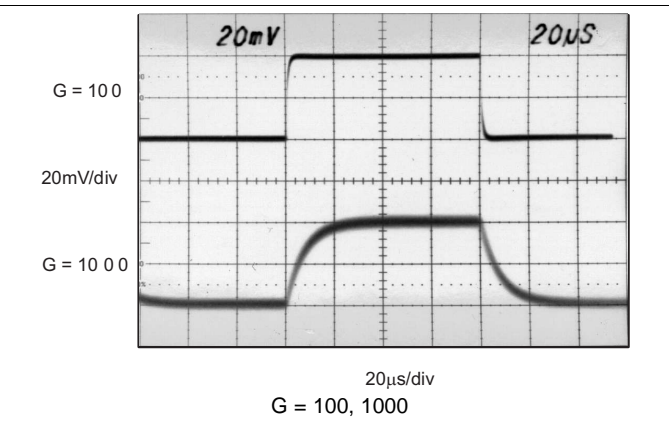

Figure 24. Small Signal

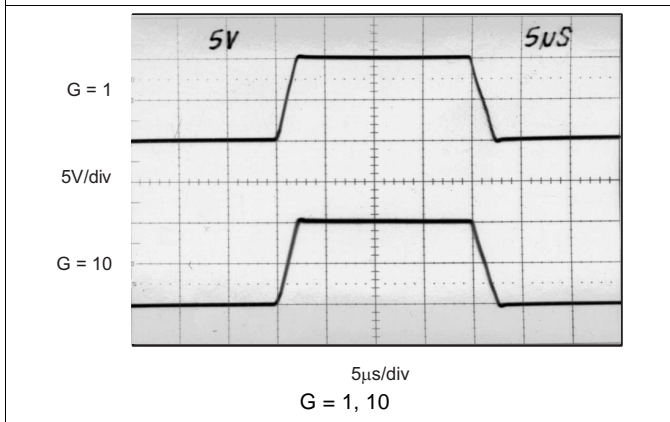

Figure 25. Large Signal

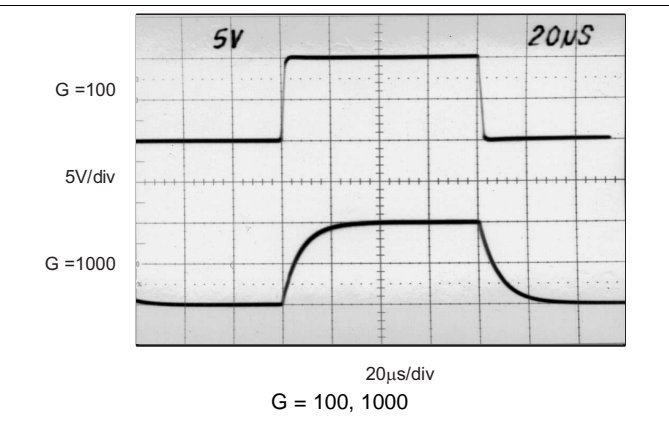

Figure 26. Large Signal

## 10 Power Supply Recommendations

The minimum power supply voltage for INA12x is  $\pm 2.25$  V and the maximum power supply voltage is  $\pm 18$  V. This minimum and maximum range covers a wide range of power supplies; but for optimum performance,  $\pm 15$  V is recommended. TI recommends adding a bypass capacitor at the input to compensate for the layout and power supply source impedance.

### 10.1 Low Voltage Operation

The INA128-HT and INA129-HT can be operated on power supplies as low as  $\pm 2.25$  V. Performance remains excellent with power supplies ranging from  $\pm 2.25$  V to  $\pm 18$  V. Most parameters vary only slightly throughout this supply voltage range.

Operation at very low supply voltage requires careful attention to assure that the input voltages remain within their linear range. Voltage swing requirements of internal nodes limit the input common-mode range with low power supply voltage. [Figure 6](#) and [Figure 7](#) show the range of linear operation for  $\pm 15$  V,  $\pm 5$  V, and  $\pm 2.5$  V supplies.

(1) OPA130 is not tested or characterized at 210°C.

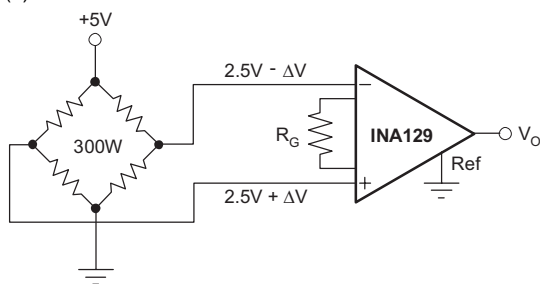

**Figure 27. Bridge Amplifier**

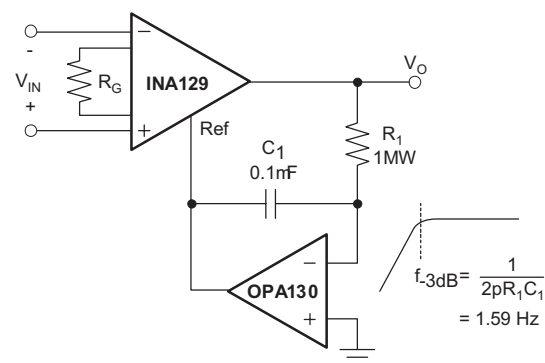

**Figure 28. AC-Coupled Instrumentation Amplifier**

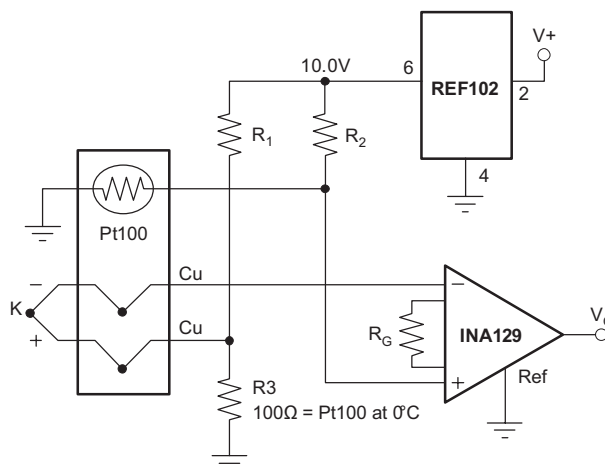

ISA TYPE	MATERIAL	SEEBECK COEFFICIENT (mV/°C)	R <sub>1</sub> , R <sub>2</sub>
E	+Chromel -Constantan	58.5	66.5kΩ
J	+Iron -Constantan	50.2	76.8kΩ
K	+Chromel -Alumel	39.4	97.6kΩ
T	+Copper -Constantan	38	102kΩ

(1) REF102 is not tested or characterized at 210°C.

**Figure 29. Thermocouple Amplifier With RTD Cold-Junction Compensation**

Low Voltage Operation (continued)

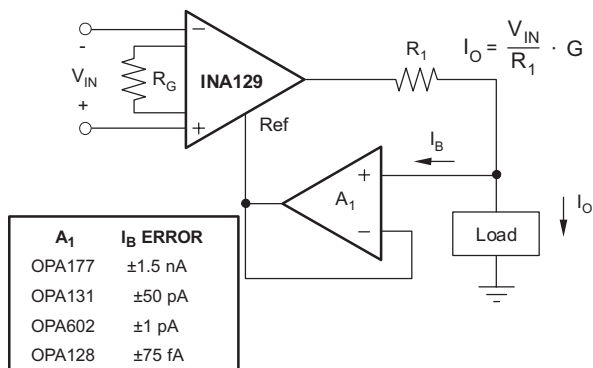

(1) OPA177, OPA131, OPA602, and OPA128 are not tested or characterized at 210°C.

Figure 30. Differential Voltage-to-Current Converter

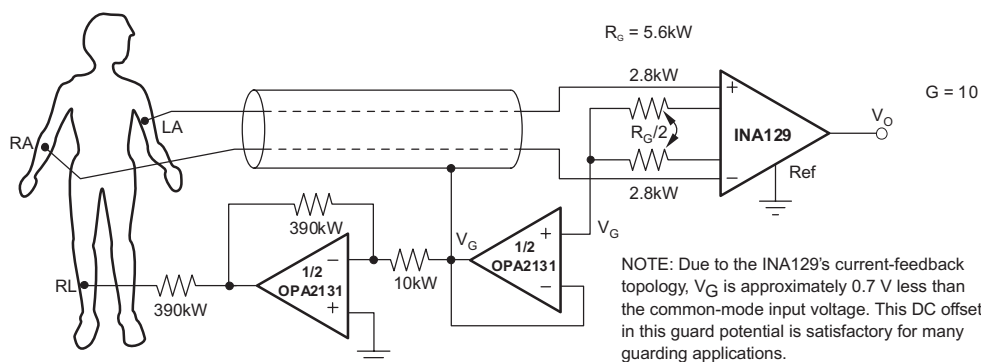

(1) OPA2131 is not tested or characterized at 210°C.

Figure 31. ECG Amplifier With Right-Leg Drive

## 11 Layout

### 11.1 Layout Guidelines

Place the power-supply bypass capacitor as closely as possible to the supply and ground pins. The recommended value of this bypass capacitor is 0.1  $\mu\text{F}$  to 1  $\mu\text{F}$ . If necessary, additional decoupling capacitance can be added to compensate for noisy or high-impedance power supplies. These decoupling capacitors must be placed between the power supply and INA12x device.

The gain resistor must be placed close to pin 1 and pin 8. This placement limits the layout loop and minimizes any noise coupling into the part.

### 11.2 Layout Example

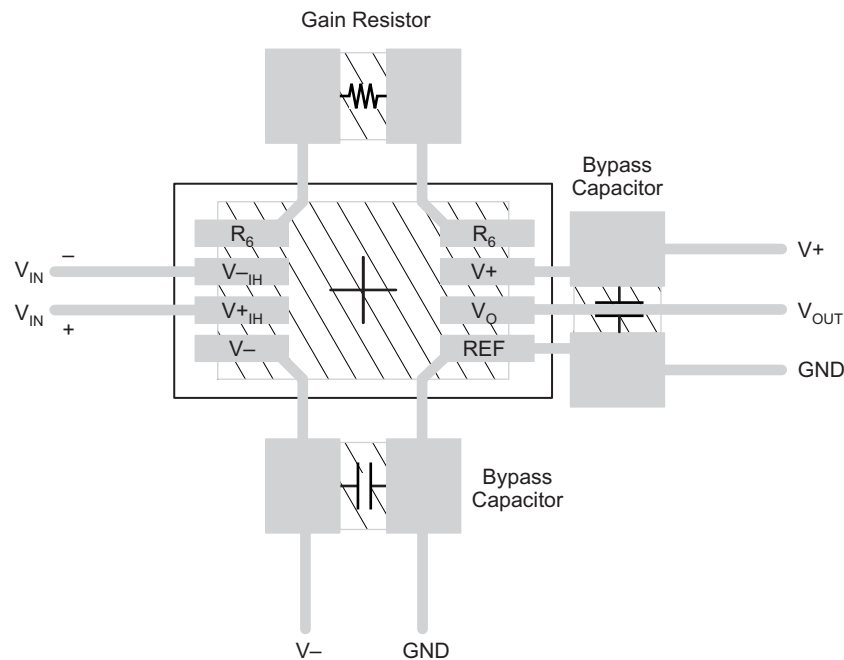

**Figure 32. Recommended Layout**

## 12 Device and Documentation Support

### 12.1 Device Support

#### 12.1.1 Development Support

**Table 1. Design Kits and Evaluation Modules**

NAME	PART NUMBER	TYPE
<a href="#">DIP Adapter Evaluation Module</a>	DIP-ADAPTER-EVM	Evaluation Modules and Boards
<a href="#">Universal Instrumentation Amplifier Evaluation Module</a>	INAEVM	Evaluation Modules and Boards

**Table 2. Development Tools**

NAME	PART NUMBER	TYPE
<a href="#">Calculate Input Common-Mode Range of Instrumentation Amplifiers</a>	INA-CMV-CALC	Calculation Tools
<a href="#">SPICE-Based Analog Simulation Program</a>	TINA-TI	Circuit Design and Simulation

### 12.2 Related Links

[Table 3](#) lists quick access links. Categories include technical documents, support and community resources, tools and software, and quick access to sample or buy.

**Table 3. Related Links**

PARTS	PRODUCT FOLDER	SAMPLE & BUY	TECHNICAL DOCUMENTS	TOOLS & SOFTWARE	SUPPORT & COMMUNITY
INA128-HT	<a href="#">Click here</a>	<a href="#">Click here</a>	<a href="#">Click here</a>	<a href="#">Click here</a>	<a href="#">Click here</a>
INA129-HT	<a href="#">Click here</a>	<a href="#">Click here</a>	<a href="#">Click here</a>	<a href="#">Click here</a>	<a href="#">Click here</a>

### 12.3 Trademarks

All trademarks are the property of their respective owners.

### 12.4 Electrostatic Discharge Caution



These devices have limited built-in ESD protection. The leads should be shorted together or the device placed in conductive foam during storage or handling to prevent electrostatic damage to the MOS gates.

### 12.5 Glossary

[SLYZ022](#) — *TI Glossary*.

This glossary lists and explains terms, acronyms, and definitions.

## 13 Mechanical, Packaging, and Orderable Information

The following pages include mechanical, packaging, and orderable information. This information is the most current data available for the designated devices. This data is subject to change without notice and revision of this document. For browser-based versions of this data sheet, refer to the left-hand navigation.

## PACKAGING INFORMATION

Orderable Device	Status (1)	Package Type	Package Drawing	Pins	Package Qty	Eco Plan (2)	Lead/Ball Finish (6)	MSL Peak Temp (3)	Op Temp (°C)	Device Marking (4/5)	Samples
INA128HD	ACTIVE	SOIC	D	8	50	Green (RoHS & no Sb/Br)	CU NIPDAU	Level-3-260C-168 HR	-55 to +175	128HD	<a href="#">Samples</a>
INA129SHKJ	ACTIVE	CFP	HKJ	8	1	TBD	Call TI	N / A for Pkg Type	-55 to 210	INA129S HKJ	<a href="#">Samples</a>
INA129SHKQ	ACTIVE	CFP	HKQ	8	1	TBD	AU	N / A for Pkg Type	-55 to 210	INA129S HKQ	<a href="#">Samples</a>
INA129SJD	ACTIVE	CDIP SB	JDJ	8	1	TBD	POST-PLATE	N / A for Pkg Type	-55 to 210	INA129SJD	<a href="#">Samples</a>
INA129SKGD1	ACTIVE	XCEPT	KGD	0	180	TBD	Call TI	N / A for Pkg Type	-55 to 210		<a href="#">Samples</a>

(1) The marketing status values are defined as follows:

**ACTIVE:** Product device recommended for new designs.

**LIFEBUY:** TI has announced that the device will be discontinued, and a lifetime-buy period is in effect.

**NRND:** Not recommended for new designs. Device is in production to support existing customers, but TI does not recommend using this part in a new design.

**PREVIEW:** Device has been announced but is not in production. Samples may or may not be available.

**OBSOLETE:** TI has discontinued the production of the device.

(2) Eco Plan - The planned eco-friendly classification: Pb-Free (RoHS), Pb-Free (RoHS Exempt), or Green (RoHS & no Sb/Br) - please check <http://www.ti.com/productcontent> for the latest availability information and additional product content details.

**TBD:** The Pb-Free/Green conversion plan has not been defined.

**Pb-Free (RoHS):** TI's terms "Lead-Free" or "Pb-Free" mean semiconductor products that are compatible with the current RoHS requirements for all 6 substances, including the requirement that lead not exceed 0.1% by weight in homogeneous materials. Where designed to be soldered at high temperatures, TI Pb-Free products are suitable for use in specified lead-free processes.

**Pb-Free (RoHS Exempt):** This component has a RoHS exemption for either 1) lead-based flip-chip solder bumps used between the die and package, or 2) lead-based die adhesive used between the die and leadframe. The component is otherwise considered Pb-Free (RoHS compatible) as defined above.

**Green (RoHS & no Sb/Br):** TI defines "Green" to mean Pb-Free (RoHS compatible), and free of Bromine (Br) and Antimony (Sb) based flame retardants (Br or Sb do not exceed 0.1% by weight in homogeneous material)

(3) MSL, Peak Temp. - The Moisture Sensitivity Level rating according to the JEDEC industry standard classifications, and peak solder temperature.

(4) There may be additional marking, which relates to the logo, the lot trace code information, or the environmental category on the device.

(5) Multiple Device Markings will be inside parentheses. Only one Device Marking contained in parentheses and separated by a "~" will appear on a device. If a line is indented then it is a continuation of the previous line and the two combined represent the entire Device Marking for that device.

<sup>(6)</sup> Lead/Ball Finish - Orderable Devices may have multiple material finish options. Finish options are separated by a vertical ruled line. Lead/Ball Finish values may wrap to two lines if the finish value exceeds the maximum column width.

**Important Information and Disclaimer:**The information provided on this page represents TI's knowledge and belief as of the date that it is provided. TI bases its knowledge and belief on information provided by third parties, and makes no representation or warranty as to the accuracy of such information. Efforts are underway to better integrate information from third parties. TI has taken and continues to take reasonable steps to provide representative and accurate information but may not have conducted destructive testing or chemical analysis on incoming materials and chemicals. TI and TI suppliers consider certain information to be proprietary, and thus CAS numbers and other limited information may not be available for release.

In no event shall TI's liability arising out of such information exceed the total purchase price of the TI part(s) at issue in this document sold by TI to Customer on an annual basis.

**OTHER QUALIFIED VERSIONS OF INA128-HT, INA129-HT :**

- Catalog: [INA128](#), [INA129](#)
- Enhanced Product: [INA129-EP](#)

NOTE: Qualified Version Definitions:

- Catalog - TI's standard catalog product
- Enhanced Product - Supports Defense, Aerospace and Medical Applications

# MECHANICAL DATA

HKJ (R-CDFP-F8)

CERAMIC DUAL FLATPACK

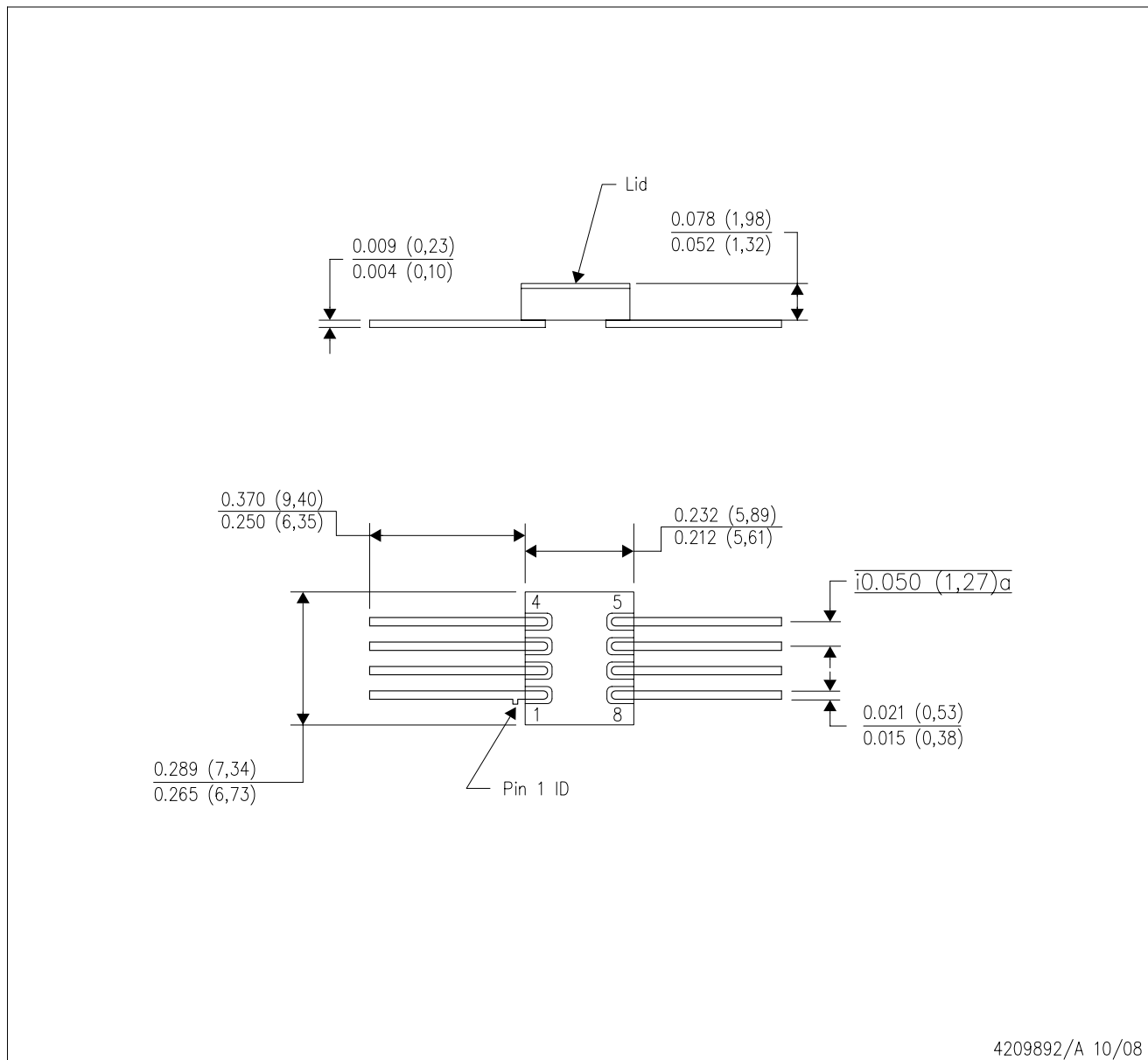

- NOTES:
- A. All linear dimensions are in inches (millimeters).
  - B. This drawing is subject to change without notice.
  - C. This package can be hermetically sealed with a metal lid.
  - D. The terminals will be gold plated.

# MECHANICAL DATA

HKQ (R-CDFP-G8)

CERAMIC GULL WING

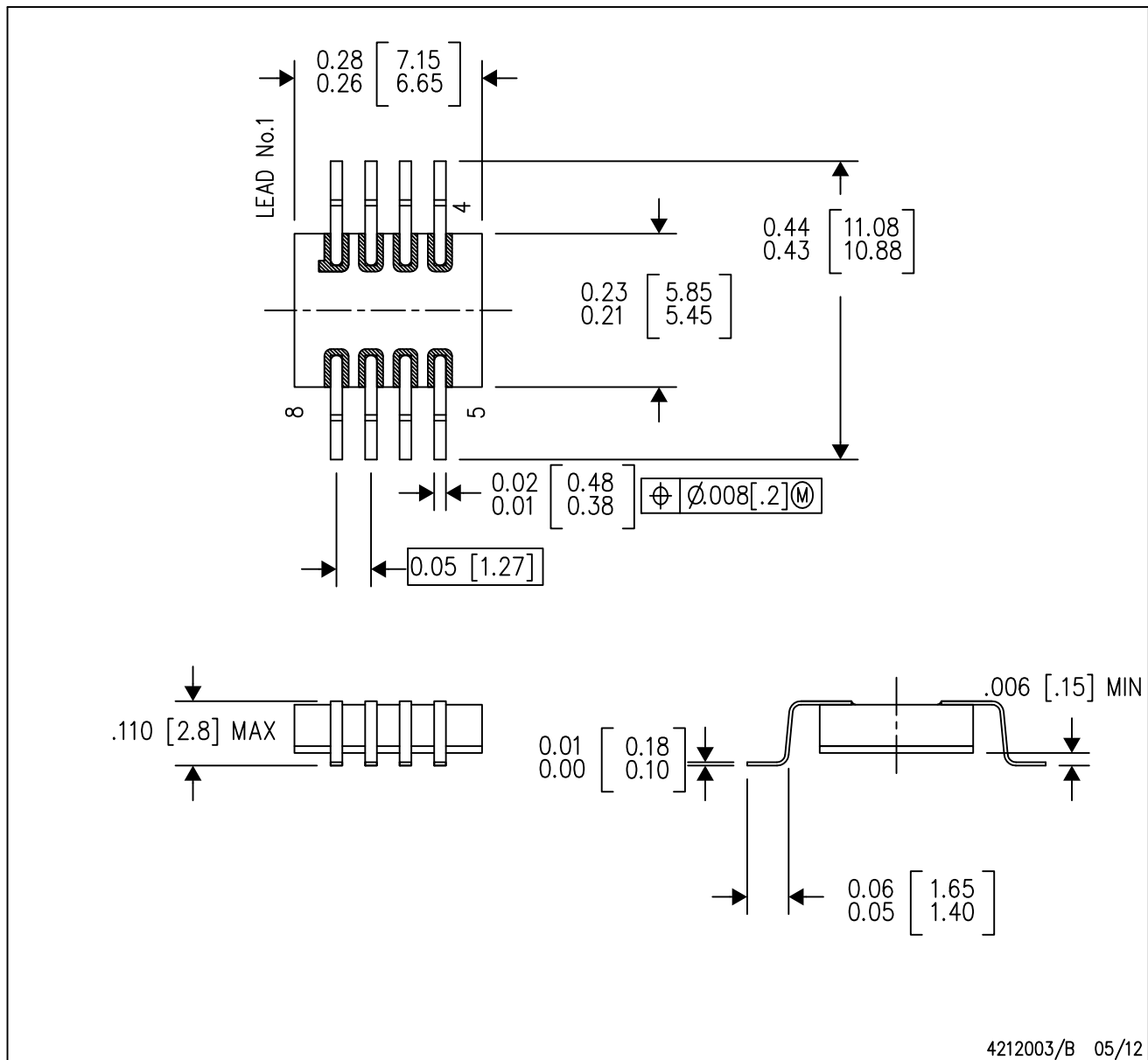

- NOTES:
- All linear dimensions are in inches (millimeters).
  - This drawing is subject to change without notice.
  - This package can be hermetically sealed with a metal lid.
  - The terminals will be gold plated.
  - Lid is not connected to any lead.

JDJ (R-CDIP-T8)

CERAMIC DUAL IN-LINE PACKAGE

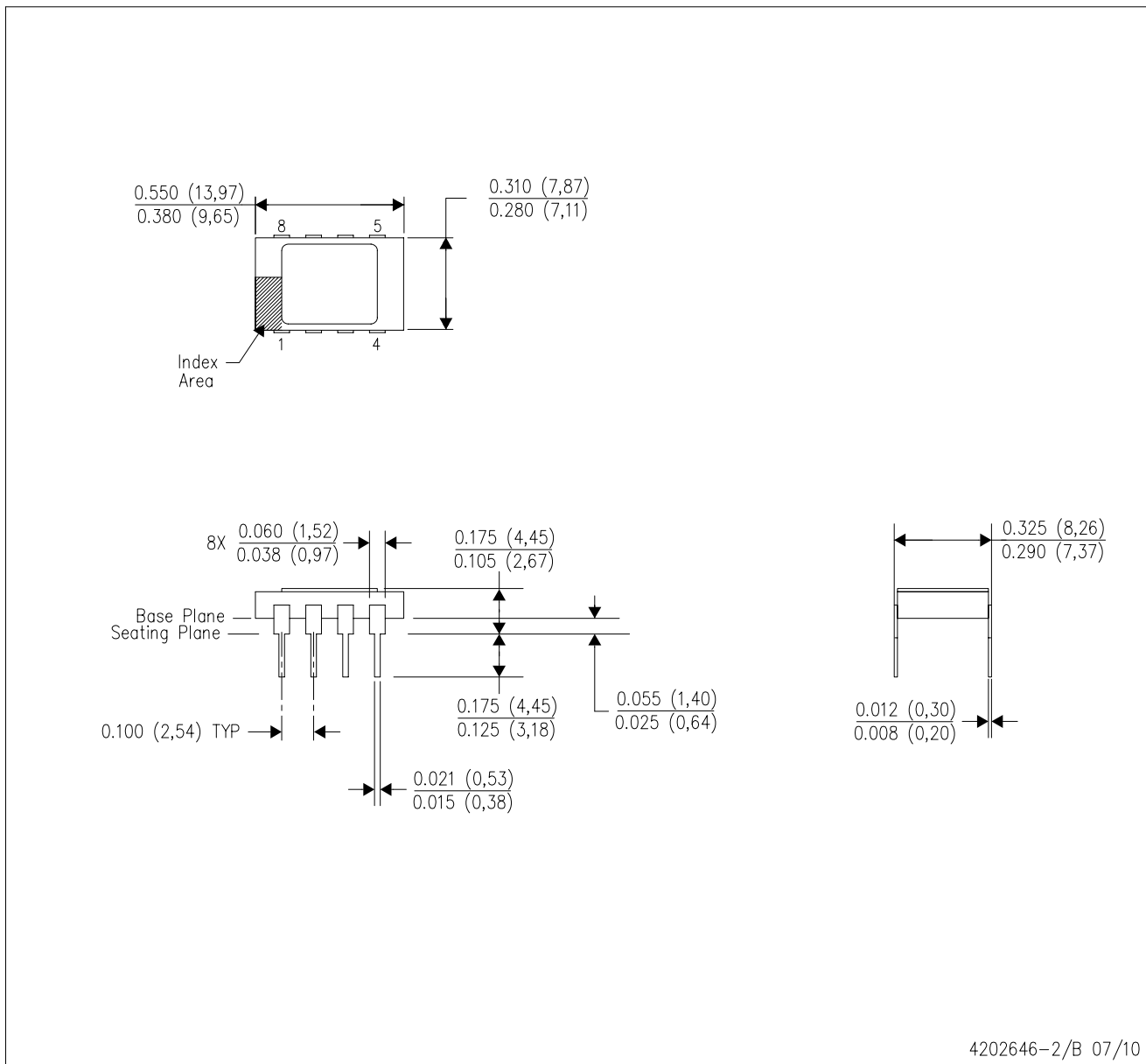

- NOTES:
- All linear dimensions are in inches (millimeters).
  - This drawing is subject to change without notice.
  - Ceramic quad flatpack with flat leads brazed to non-conductive tie bar carrier.
  - This package is hermetically sealed with a metal lid.
  - The leads are gold plated and can be solderdipped.
  - Leads not shown for clarity purposes.
  - Lid and heat sink are connected to GND leads.



D (R-PDSO-G8)

PLASTIC SMALL OUTLINE

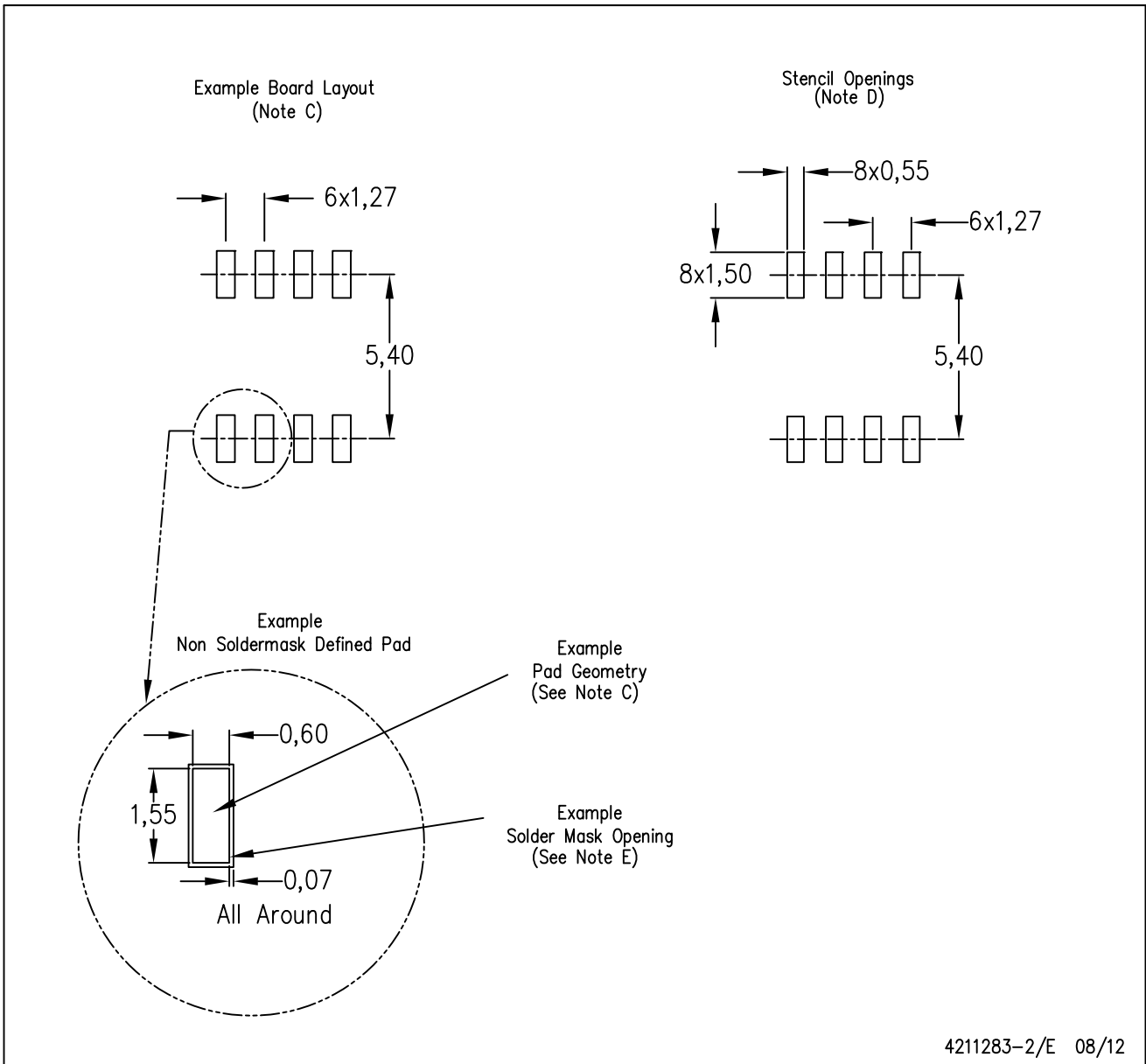

- NOTES:
- A. All linear dimensions are in millimeters.
  - B. This drawing is subject to change without notice.
  - C. Publication IPC-7351 is recommended for alternate designs.
  - D. Laser cutting apertures with trapezoidal walls and also rounding corners will offer better paste release. Customers should contact their board assembly site for stencil design recommendations. Refer to IPC-7525 for other stencil recommendations.
  - E. Customers should contact their board fabrication site for solder mask tolerances between and around signal pads.

## IMPORTANT NOTICE

Texas Instruments Incorporated and its subsidiaries (TI) reserve the right to make corrections, enhancements, improvements and other changes to its semiconductor products and services per JESD46, latest issue, and to discontinue any product or service per JESD48, latest issue. Buyers should obtain the latest relevant information before placing orders and should verify that such information is current and complete. All semiconductor products (also referred to herein as "components") are sold subject to TI's terms and conditions of sale supplied at the time of order acknowledgment.

TI warrants performance of its components to the specifications applicable at the time of sale, in accordance with the warranty in TI's terms and conditions of sale of semiconductor products. Testing and other quality control techniques are used to the extent TI deems necessary to support this warranty. Except where mandated by applicable law, testing of all parameters of each component is not necessarily performed.

TI assumes no liability for applications assistance or the design of Buyers' products. Buyers are responsible for their products and applications using TI components. To minimize the risks associated with Buyers' products and applications, Buyers should provide adequate design and operating safeguards.

TI does not warrant or represent that any license, either express or implied, is granted under any patent right, copyright, mask work right, or other intellectual property right relating to any combination, machine, or process in which TI components or services are used. Information published by TI regarding third-party products or services does not constitute a license to use such products or services or a warranty or endorsement thereof. Use of such information may require a license from a third party under the patents or other intellectual property of the third party, or a license from TI under the patents or other intellectual property of TI.

Reproduction of significant portions of TI information in TI data books or data sheets is permissible only if reproduction is without alteration and is accompanied by all associated warranties, conditions, limitations, and notices. TI is not responsible or liable for such altered documentation. Information of third parties may be subject to additional restrictions.

Resale of TI components or services with statements different from or beyond the parameters stated by TI for that component or service voids all express and any implied warranties for the associated TI component or service and is an unfair and deceptive business practice. TI is not responsible or liable for any such statements.

Buyer acknowledges and agrees that it is solely responsible for compliance with all legal, regulatory and safety-related requirements concerning its products, and any use of TI components in its applications, notwithstanding any applications-related information or support that may be provided by TI. Buyer represents and agrees that it has all the necessary expertise to create and implement safeguards which anticipate dangerous consequences of failures, monitor failures and their consequences, lessen the likelihood of failures that might cause harm and take appropriate remedial actions. Buyer will fully indemnify TI and its representatives against any damages arising out of the use of any TI components in safety-critical applications.

In some cases, TI components may be promoted specifically to facilitate safety-related applications. With such components, TI's goal is to help enable customers to design and create their own end-product solutions that meet applicable functional safety standards and requirements. Nonetheless, such components are subject to these terms.

No TI components are authorized for use in FDA Class III (or similar life-critical medical equipment) unless authorized officers of the parties have executed a special agreement specifically governing such use.

Only those TI components which TI has specifically designated as military grade or "enhanced plastic" are designed and intended for use in military/aerospace applications or environments. Buyer acknowledges and agrees that any military or aerospace use of TI components which have **not** been so designated is solely at the Buyer's risk, and that Buyer is solely responsible for compliance with all legal and regulatory requirements in connection with such use.

TI has specifically designated certain components as meeting ISO/TS16949 requirements, mainly for automotive use. In any case of use of non-designated products, TI will not be responsible for any failure to meet ISO/TS16949.

### Products

Audio	<a href="http://www.ti.com/audio">www.ti.com/audio</a>
Amplifiers	<a href="http://amplifier.ti.com">amplifier.ti.com</a>
Data Converters	<a href="http://dataconverter.ti.com">dataconverter.ti.com</a>
DLP® Products	<a href="http://www.dlp.com">www.dlp.com</a>
DSP	<a href="http://dsp.ti.com">dsp.ti.com</a>
Clocks and Timers	<a href="http://www.ti.com/clocks">www.ti.com/clocks</a>
Interface	<a href="http://interface.ti.com">interface.ti.com</a>
Logic	<a href="http://logic.ti.com">logic.ti.com</a>
Power Mgmt	<a href="http://power.ti.com">power.ti.com</a>
Microcontrollers	<a href="http://microcontroller.ti.com">microcontroller.ti.com</a>
RFID	<a href="http://www.ti-rfid.com">www.ti-rfid.com</a>
OMAP Applications Processors	<a href="http://www.ti.com/omap">www.ti.com/omap</a>
Wireless Connectivity	<a href="http://www.ti.com/wirelessconnectivity">www.ti.com/wirelessconnectivity</a>

### Applications

Automotive and Transportation	<a href="http://www.ti.com/automotive">www.ti.com/automotive</a>
Communications and Telecom	<a href="http://www.ti.com/communications">www.ti.com/communications</a>
Computers and Peripherals	<a href="http://www.ti.com/computers">www.ti.com/computers</a>
Consumer Electronics	<a href="http://www.ti.com/consumer-apps">www.ti.com/consumer-apps</a>
Energy and Lighting	<a href="http://www.ti.com/energy">www.ti.com/energy</a>
Industrial	<a href="http://www.ti.com/industrial">www.ti.com/industrial</a>
Medical	<a href="http://www.ti.com/medical">www.ti.com/medical</a>
Security	<a href="http://www.ti.com/security">www.ti.com/security</a>
Space, Avionics and Defense	<a href="http://www.ti.com/space-avionics-defense">www.ti.com/space-avionics-defense</a>
Video and Imaging	<a href="http://www.ti.com/video">www.ti.com/video</a>

### TI E2E Community

[e2e.ti.com](http://e2e.ti.com)