



Part Number
Key Word



Site Search

TOP

NEWS RELEASE

CONNECTOR SEARCH

CATALOG



SAMPLE

STOCK CHECK

[TOP](#) > [IL-Z-6S-S125C3](#)

Product List

Product Name	IL-Z-6S-S125C3
Series Name	IL-Z Series
Lead free	Yes
Contact pitch (mm)	1.25
Connector types	Socket housing
Number of contacts	6
PCB side connector styles	-
PCB mounting method	-
SMT	-
Termination styles	Crimp
Mating side contact finish	-
Mouting side contact length (mm)	

Remarks	Contact sell separately
Related Documents	 409Kbytes  102Kbytes  209Kbytes
Pair	

Notice:

1. The values specified in this web site are only for reference. The products and their specifications are subject to change without notice. Contact our sales staff for further information before considering or ordering any of our products.
For purchase, a product specification must be agreed upon.
2. Users are requested to provide protection circuits and redundancy circuits to ensure safety of the equipment, and sufficiently review the suitability of JAE's products to the equipment.
3. The products presented in this web site are designed for the uses recommended below. We strongly suggest you contact our sales staff when considering use of any of the products in any other way than the recommended applications or for a specific use that requires an extremely high reliability.

(1) Applications that require consultation:

- (i) Please contact us if you are considering use involving a quality assurance program that you specify or that is peculiar to the industry, such as:
Automotive electrical components, train control, telecommunications devices (mainline), traffic light control, electric power, combustion control, fire prevention or security systems, disaster evention equipment, etc.

(ii) We may separately give you our support with a quality assurance program that you specify, when you think of a use such as :

Aviation or space equipment, submarine repeaters, nuclear power control systems, medical equipment for life support, etc.

(2) Recommended applications include:

Computers, office appliances, telecommunications devices (terminals, mobile units), measuring equipment, audiovisual equipment, home electric appliances, factory automation equipment, etc

0221770
(DRAWING NO.) 台要図

版数 REV.	年月日 DATE	DCN NO.	変更内容 DESCRIPTION	製図 DR.	担当 CHK.	査閲 APPD.	承認 APPD.
4	1999.10.1	44824	再トレース	高橋	斎藤(雄)	—	用印

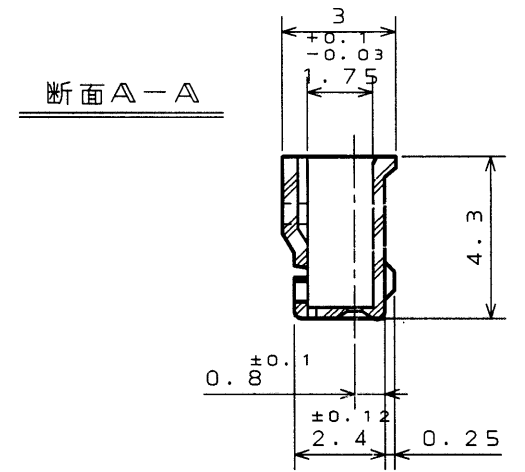
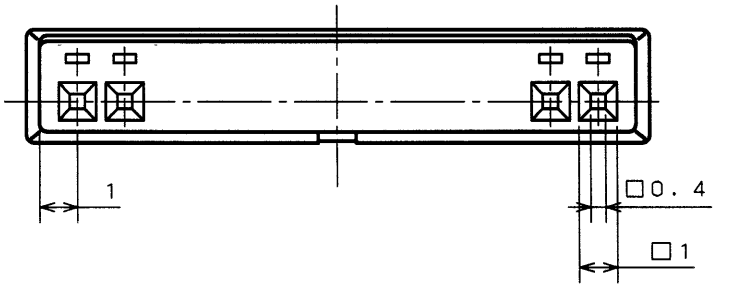
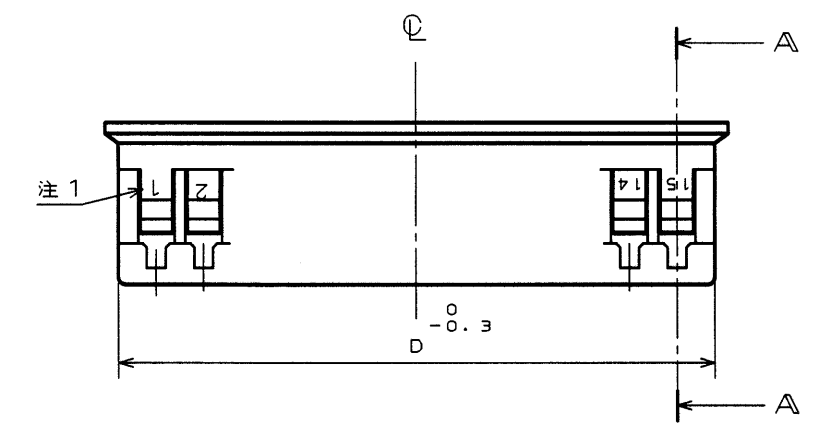
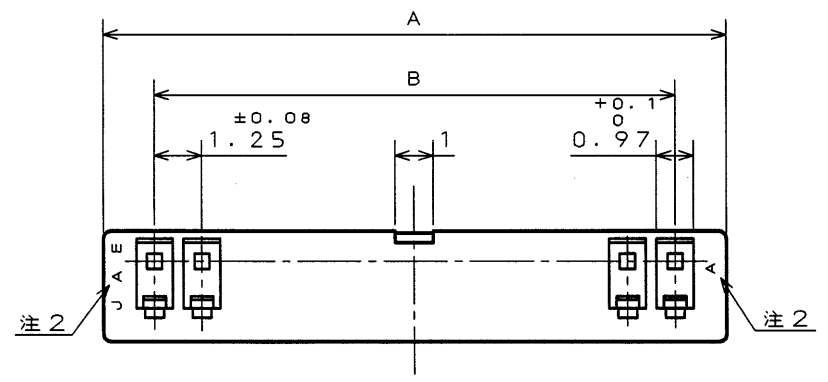

命名法



表 1

名称	芯数	A ±0.25	B ±0.15	D -0.3
IL-Z-2S-S125C3-*	2	3.95	1.25	3.25
↑	↑	↑	↑	↑
3	3	5.2	2.5	4.5
4	4	6.45	3.75	5.75
5	5	7.7	5	7
6	6	8.95	6.25	8.25
7	7	10.2	7.5	9.5
8	8	11.45	8.75	10.75
9	9	12.7	10	12
10	10	13.95	11.25	13.25
11	11	15.2	12.5	14.5
12	12	16.45	13.75	15.75
13	13	17.7	15	17
14	14	18.95	16.25	18.25
↓	↓	↓	↓	↓
IL-Z-15S-S125C3-*	15	20.2	17.5	19.5

注 1 端子NO. (1~15)ヲ浮キ出ス。
注 2 社標及ピCavマークヲ浮キ出ス。

1	インシュレータ	1	15%ガラス入り 6-6ナイロン	仕上 FINISH	備考 REMARKS
符号 NO.	名称 DESCRIPTION	個数 QTY.	材料 MATERIAL		
仕様書 (SPECIFICATION)		第1版 (ORIGINAL DATE) 1987.2.19		JAE-CONNECTOR.COM	
一般公差 (GENERAL TOLERANCE)		製図 DR.	村野	名称 (TITLE) ソケットハウジング	
寸法 (DIMENSION)	角度 (ANGLES)	担当 CHK.	遠藤 小菅	JAE JAPAN AVIATION ELECTRONICS INDUSTRY, LTD.	
. ±0.3	×° ±	査閲 APPD.	鈴木	図面番号 (DRAWING NO.) SJ021770	
.× ±0.2	×°× ±	承認 APPD.	市村 藤野	版数 (REV.) 4	
.×× ±0.1					
.××× ±					

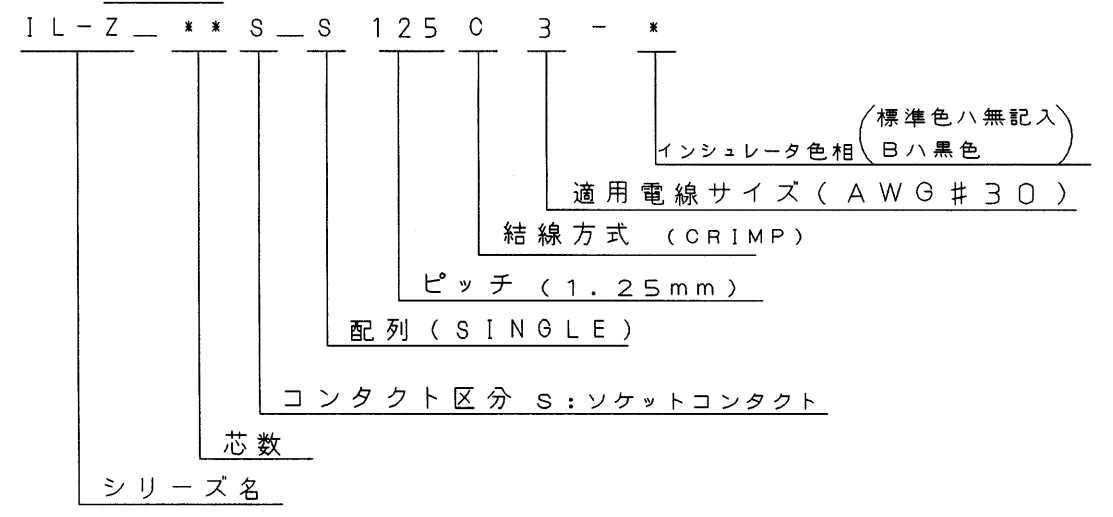
DCF-O-212D(98.02)

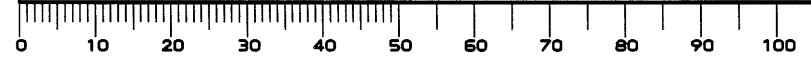

JAE Connector Div. Proprietary.
Copyright © Japan Aviation Electronics Industry, Ltd.

本図面は日本航空電子工業(株)の所有する情報を含むもので当社の許可なく複製を禁止する。
THIS DRAWING CONTAINS INFORMATION THAT IS PROPRIETARY TO JAE AND CAN NOT BE REPRODUCED WITHOUT WRITTEN CONSENT OF JAE.

JAPAN AVIATION ELECTRONICS IND., LTD. CONNECTOR DIVISION 日本航空電子工業株式会社 コネクタ事業部 THIS SPECIFICATION TABLE CANNOT BE REPRODUCED WITHOUT WRITTEN CONSENT OF JAE. この製品規格表は日本航空電子工業株式会社の 許可のない限り複写を禁じます。		SPECIFICATION TABLE 製品規格表		Connector Specification No. JACS-1266-0	
				Connector Series Name 品名 IL-Z series connector	
				Applicable Drawing No. 製品図面 Pinheader: SJ021769, SJ021832 Housing: SJ021770 Contact : SJ021771	
				TK C	
Rev. 版数	Date 発行日	DCN No	Drawn by 担当	Checked by 査閲	Approved by 承認
1	7 Jul. 1988	-	Kosuge	-	Fujio
4	16 Nov. 1999	45130	Takahashi	-	Amemiya
5	27 Jan. 2003	51426	<i>Takahashi</i>	-	<i>S. Kashiwagi</i>
Standard data 定格					
Applicable wire 適合電線		AWG #28 to #32			
Rated current 電流		1A per contact AC,DC 各 1A/1 端子当り			
Rated voltage 電圧		200V AC,DC 200V			
Operating temperature range 使用温度範囲		- 40 °C to + 70 °C			
Note 備考 This specification covers the requirements for IL-Z series connector, which consists of Pinheader mated with the crimped contacts assembled in the housing, unless otherwise specified. 特に規定のない場合は、圧着ソケットコンタクトをハウジングに入れ、ピンヘッダとの嵌合についての性能を規定する					
Item		Procedure 試験方法		Requirement 規定	
MECHANICAL 機械的性能					
Examination of product 構造寸法表示		Visual, dimensional and functional inspection.		Meets requirements of product drawing. 図面と相違のないこと	
Material & finish 材料仕上加工法				Meets requirements of product drawing. 図面と相違のないこと	
Connector mating force 総合挿入力		Measure force necessary to mate between the counterpart connectors. 適合コネクタ間にて挿入を行う		Fig-1 表-1	
Connector unmating force 総合抜去力		Measure force necessary to unmate between the counterpart connectors. 適合コネクタ間にて抜去を行う		Fig-1 表-1	
Contact extraction force 単体抜去力		Extract the 0.35mm square steel pin from the socket contact. □0.35 スティールとソケット コンタクト間にて抜去を行う		0.3N Min. (without the lock part) 0.3N 以上 (LOCK 部を除く)	
Durability 寿命試験		Mate and unmate the connector for 50 cycles. 50 回の挿抜を行う。		Contact resistance: 40mΩ (Max.) 接触抵抗: 40mΩ 以下	

Item	Procedure 試験方法	Requirement 規定								
Vibration 耐振性	Subject specimens to 10 ~ 55 Hz at 1.5mm amplitude, 2hours in each of 3axes, 6hours in total 全振巾 1.5mm , 10~55Hz 各 2h 計 3 軸 6h	No electrical discontinuity more than 1 μ s . No damage. 1 μ s 以上の電氣的瞬断がないこと。 部品に機械的欠陥がないこと。								
Shock 耐衝撃性	490m/s ² Applying an appropriate holder is allowed in Vibration test and Shock test. 衝撃試験: 490m/s ² 3 軸 (振動 & 衝撃試験に於いては、取付けに適当なホルダーを使用してもよい)									
Contact retention コンタクト保持力	Measure the contact retention with Tensile strength tester. 引張試験機にてコンタクト保持力を測定	5N per contact Min. 1 本 5N 以上								
Tensile strength (Crimped connections) 圧着強度	Measure the tensile strength of the crimped contact. (Do not crimp insulation part.) 引張試験機にてソケットコンタクト芯線圧着部の引張強度を測定する(被覆部は圧着しない)	<table border="1"> <thead> <tr> <th>AWG#</th> <th>28</th> <th>30</th> <th>32</th> </tr> </thead> <tbody> <tr> <td>Spec. N min.</td> <td>14</td> <td>10</td> <td>6</td> </tr> </tbody> </table> <p>Note) As for unspecified wire sizes in this specification, specify define values with clients. 注)本仕様書に規定しない電線サイズについては、得意先と調整し規格値を設定する</p>	AWG#	28	30	32	Spec. N min.	14	10	6
AWG#	28	30	32							
Spec. N min.	14	10	6							
ELECTRICAL 電氣的性能										
Voltage proof 耐電圧	Apply the specified voltage between adjacent contacts. 近接コンタクト間に規格電圧を印加	500V AC r.m.s. No breakdown caused for 1 minute. AC 500V r.m.s.1 分間異常のないこと								
Insulation resistance 絶縁抵抗	Apply 500V DC between adjacent contacts and measure its resistance within 1 minute. 近接コンタクト間に 500V DC を印加し 1 分以内で測定	100M Ω (Min.) 100M Ω 以上								
Contact resistance 接触抵抗	Measure it with low voltage less than 20mV and 1mA 20V、1mA にて測定	20m Ω (Max.) 20m Ω 以下								
ENVIRONMENTAL 環境的性能										
Rapid change of temperature 熱衝撃	Subject specimens to continuous 5 cycles between -55 $^{\circ}$ C and +85 $^{\circ}$ C 30minutes each. 熱衝撃試験 -55 $^{\circ}$ C~+85 $^{\circ}$ C連続 5 サイクル	Insulation resistance: 50M Ω (Min.) Voltage proof: 250V AC r.m.s. , 1 minute. No breakdown. Contact resistance: 40m Ω (Max.)								
Damp heat , steady state 耐湿性	Subject specimens to 40 $^{\circ}$ C at 90-95% RH for 96 hours. (Fig. 3) 湿度試験 40 $^{\circ}$ C 90~95%RH 96h (図 3)	絶縁抵抗:50M Ω 以上 耐電圧AC250Vr.m.s. 1分間異常ないこと 接触抵抗:40m Ω 以下								
Solderability 半田付け性	After dipping in the flux for 5 to 10 seconds, dip in Sn:Pb=60:40 solder of 230 $^{\circ}$ C \pm 5 $^{\circ}$ C for 3 \pm 0.5 seconds. 適合フラックスに 5~10 秒浸漬し、Sn:Pb=60:40 半田 230 \pm 5 $^{\circ}$ Cに 3 \pm 0.5 秒浸漬する。	Wet Solder Coverage: 95% (Min). 浸した部分の 95%以上が、半田で覆われていること								
Resistance to soldering heat, solder bath method 半田耐熱性	Leave the connector in the 260 $^{\circ}$ C \pm 5 $^{\circ}$ C chamber for 5 seconds. 260 \pm 5 $^{\circ}$ Cの恒温槽に 5 秒間放置する	Contact retention: 5N Min. コンタクト保持力 5N 以上								
Dry heat (High temperature) 耐熱性	Subject specimens to 70 $^{\circ}$ C for 96 hours 耐熱試験: 70 $^{\circ}$ C, 96h	Contact resistance: 40m Ω Min. 接触抵抗 40m Ω 以下								

Item	Procedure 試験方法	Requirement 規定
Corrosion, salt mist 耐腐食性	Subject specimens to 5% salt concentration at 35 °C for 48 hours. 塩水噴霧試験 塩水濃度 5% 35°C 48h	There should be no corrosion detrimental to contact connection. Contact resistance: 40mΩ (Max.) コンタクトの接触上有害な腐食が生じないこと 接触抵抗:40mΩ 以下

Fig. 1 Total mating / unmating force 表-1 総合挿入抜去力

Pin 芯数	Connector mating force "N" (Max.) 総合挿入力 N 以下	Connector unmating force "N" (Min.) 総合抜去力 N 以上
2	20	5.0
3	25	5.5
4	30	6.0
5	35	6.5
6	40	7.0
7	45	7.5
8	50	8.0
9	55	8.5
10	60	9.0
11	65	9.5
12	70	10.0
13	75	10.5
14	80	11.0
15	85	11.5