

# Low Dropout Positive Voltage Regulator

## Description



The IL1117C is a series of low dropout voltage regulators which can provide up to 1A of output current. The IL1117C is available in eight fixed voltage, 1.5, 1.8, 2.5, 2.85, 3.0, 3.3, 3.5 and 5.0V. Additionally it is also available in adjustable version. On chip precision trimming adjusts the reference/ output voltage to within  $\pm 2\%$ . Current limit is also trimmed to ensure specified output current and controlled short-circuit current.

The IL1117C series is available in SOT-223, TO-252, SOT-89 packages.

A minimum of 10uF tantalum capacitor is required at the output to improve the transient response and Stability.

### Features

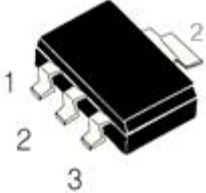
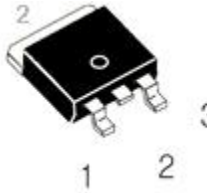
- Dropout Voltage – 1.2V (Typical)
- Reference/Output Voltage Trimmed to  $\pm 2\%$
- Maximum Input Voltage – 15V
- Adjustable Output Voltage or Fixed  
1.2V, 1.25V, 1.5V, 1.8V, 2.5V, 2.85V, 3.3V, 5V
- Line Regulation typically at 0.2% max
- Load Regulation typically at 0.4% max
- Current Limiting and Thermal Protection
- Standard 3-Pin Power Packages
- Operating Junction Temperature Range  
-40 to +125°C
- MSL (Moisture Sensitive Level) 3

<p>SOT-223</p>  <p>IL1117C-xxET</p>	<p>TO-252</p>  <p>IL1117C-xxD0T</p>
<p>SOT-89</p>  <p>IL1117C-xxPT</p>	<p>1. ADJ/GND 2. Output 3. Input</p> <p>Pin#2 connected with heat sink</p>

## Applications

- Post Regulator for switching DC/DC Converter
- High Efficiency Linear Regulator
- Battery Chargers
- PC Add on Card
- Motherboard clock supplies
- LCD Monitor
- Set-top Box

## ORDERING INFORMATION

Device	Package	Packing
IL1117C-xxET	SOT-223	Tape & Reel
IL1117C-xxD0T	TO-252	Tape & Reel
IL1117C-xxPT	SOT-89	Tape & Reel

## Absolute Maximum Ratings

Symbol	Description	Max	Units
VIN	Input Voltage	15	V
PD	Internally Limited (Note 1)		W
TJ	Operating Junction Temperature Range (* in case of IL1117C-1.2ET)	-40 to 125 (* 0 to 150)	°C
Ts	Storage Temperature Range	-50 to 150	°C
ΘJA	Thermal Resistance Junction-to-Ambient (SOT-223)	170	°C/W
ΘJA	Thermal Resistance Junction-to-Ambient (TO-252)	115	°C/W
ΘJA	Thermal Resistance Junction-to-Ambient (SOT-89)	250	°C/W
ΘJC	Thermal Resistance Junction-to-Case (SOT-223)	40	°C/W
ΘJC	Thermal Resistance Junction-to-Case (TO-252)	25	°C/W
ΘJC	Thermal Resistance Junction-to-Case (SOT-89)	65	°C/W
ESD	ESD HBM Protection max level (Note 2)	±2000	V

\* Stresses beyond those listed under “absolute maximum ratings” may cause permanent damage to the device.

These are stress ratings only and functional operation of the device at these or any other conditions beyond those indicated under “recommended operating conditions” is not implied.

Exposure to absolute-maximum-rated conditions for extended periods may affect device reliability.

Note 1: The maximum power dissipation is a function of  $T_{J(MAX)}$ ,  $\Theta_{JA}$  and  $T_A$ . The maximum allowable power dissipation at ambient temperature is  $PD = (T_{J(MAX)} - T_A)/\Theta_{JA}$ .

Note 2: For testing purposes, ESD was applied using human body model, 1.5kΩ in series with 100pF.

**Electrical Characteristics**

T<sub>J</sub> = -40°C to +125°C unless otherwise specified

PARAMETER	CONDITIONS	MIN	TYP	MAX	UNIT
<b>OUTPUT VOLTAGE</b>					
IL1117C-1.25 (Adjustable)	I <sub>o</sub> = 10mA to I <sub>FULLLOAD</sub> <sup>1)</sup> Vin = 2.75 to 12.0V	1.225	1.250	1.275	V
IL1117C-1.5	I <sub>o</sub> = 10mA to I <sub>FULLLOAD</sub> , Vin = 3.0 to 12.0V	1.470	1.500	1.530	
IL1117C-1.8	I <sub>o</sub> = 10mA to I <sub>FULLLOAD</sub> , Vin = 3.3 to 12.0V	1.764	1.800	1.836	
IL111C-2.5	I <sub>o</sub> = 10mA to I <sub>FULLLOAD</sub> , Vin = 4.0 to 12.0V	2.450	2.500	2.550	
IL1117C-2.85	I <sub>o</sub> = 10mA to I <sub>FULLLOAD</sub> , Vin = 4.35 to 12.0V	2.793	2.850	2.907	
IL1117C-3.0	I <sub>o</sub> = 10mA to I <sub>FULLLOAD</sub> , Vin = 4.5 to 12.0V	2.940	2.850	3.060	
IL1117C-3.3	I <sub>o</sub> = 10mA to I <sub>FULLLOAD</sub> , Vin = 4.8 to 12.0V	3.234	3.300	3.366	
IL1117C-3.5	I <sub>o</sub> = 10mA to I <sub>FULLLOAD</sub> , Vin = 5.5 to 12.0V	3.430	3.500	3.570	
L1117C-5.0	I <sub>o</sub> = 10mA to I <sub>FULLLOAD</sub> , Vin = 6.5 to 15.0V	4.900	5.000	5.100	
<b>LINE REGULATION</b>					
IL1117C-1.25 (Adjustable)	I <sub>o</sub> = 10mA, Vin = 2.75 to 12.0V		0.1	0.3	%
IL1117C-1.5	I <sub>o</sub> = 10mA, Vin = 3.0 to 12.0V		1.0	10.0	mV
IL1117C-1.8	I <sub>o</sub> = 10mA, Vin = 3.3 to 12.0V		1.2	10.0	mV
IL111C-2.5	I <sub>o</sub> = 10mA, Vin = 4.0 to 12.0V		1.0	10.0	mV
IL1117C-2.85	I <sub>o</sub> = 10mA, Vin = 4.35 to 12.0V		2.0	10.0	mV
IL1117C-3.0	I <sub>o</sub> = 10mA, Vin = 4.5 to 12.0V		2.0	10.0	mV
IL1117C-3.3	I <sub>o</sub> = 10mA, Vin = 4.8 to 12.0V		3.0	10.0	mV
IL1117C-3.5	I <sub>o</sub> = 10mA, Vin = 5.0 to 12.0V		3.0	10.0	mV
L1117C-5.0	I <sub>o</sub> = 10mA, Vin = 6.5 to 15.0V		7.0	15.0	mV
<b>LOAD REGULATION</b>					
IL1117C-1.25 (Adjustable)	I <sub>o</sub> = 10mA to 1.0A, Vin = 3.25V		0.2	0.5	%
IL1117C-1.5	I <sub>o</sub> = 10mA to 1.0A, Vin = 3.5V		0.2	12.0	mV
IL1117C-1.8	I <sub>o</sub> = 10mA to 1.0A, Vin = 3.8V		2.0	12.0	mV
IL111C-2.5	I <sub>o</sub> = 10mA to 1.0A, Vin = 4.5V		2.0	12.0	mV
IL1117C-2.85	I <sub>o</sub> = 10mA to 1.0A, Vin = 4.85V		2.0	12.0	mV
IL1117C-3.0	I <sub>o</sub> = 10mA to 1.0A, Vin = 5.0V		2.0	12.0	mV
IL1117C-3.3	I <sub>o</sub> = 10mA to 1.0A, Vin = 5.3V		2.0	12.0	mV
IL1117C-3.5	I <sub>o</sub> = 10mA to 1.0A, Vin = 5.5V		2.0	15.0	mV
L1117C-5.0	I <sub>o</sub> = 10mA to 1.0A, Vin = 7.0V		14.0	20.0	mV
<b>DROPOUT VOLTAGE</b> <sup>2)</sup>					
All Models	I <sub>o</sub> = 1A (T <sub>J</sub> = 25°C)		1.20	1.40	V
	I <sub>o</sub> = 1A (T <sub>J</sub> = -40°C to +125°C)		1.20	1.55	V
Current Limit	V <sub>in</sub> - V <sub>o</sub> = 5V (T <sub>J</sub> = 25°C)	1000	1500		mA
Minimum Load Current Adjustable Models	V <sub>in</sub> = 13.75V		2	7	mA
Quiescent Current	V <sub>in</sub> - V <sub>o</sub> = 1.5V		5.2	10	mA
Adjust Pin Current	I <sub>o</sub> = 10mA, V <sub>in</sub> - V <sub>o</sub> = 1.4 to 10V		56	80	uA
Adjust Pin Current Change	I <sub>o</sub> = 10mA to 1A, V <sub>in</sub> - V <sub>o</sub> = 1.4 to 10V		0.5	5	uA
Temperature Drift	T <sub>J</sub> = -40°C to +125°C		0.5		%
RMS Output Noise	Bandwidth of 10Hz to 10kHz at 25°C		0.003		%V <sub>o</sub>
Ripple Rejection Ratio	120Hz input Ripple(CADJ for ADJ) = 25uF V <sub>in</sub> - V <sub>o</sub> = 5V, I <sub>o</sub> = 1.0A T <sub>J</sub> = -40°C to +125°C	60	72		dB

NOTES:

1) IFULL LOAD, A, - current limit is a function of input-to-output (max 1A),

Defines as:  $I_{FULL\ LOAD} = P_{D\ MAX} / (V_{in} - V_o)$ , where

$P_{D\ MAX}$  – maximum operation power dissipation defines as  $P_{D\ MAX} = (T_J - T_A) / \Theta_{J-A}$ ,

$T_J$  – maximum operation junction temperature, 125°C;

$T_A$  – maximum operation ambient temperature, °C;

$\Theta_{J-A}$  – thermal resistance junction- to-ambient, °C/W.

2) The dropout voltage is the input/output differential at which the circuit ceases to regulate against further reduction in input voltage. It is measured when the output voltage has dropped at 100mV from the nominal value obtained at  $V_{IN} = V_{OUT} + 1.5V$ .

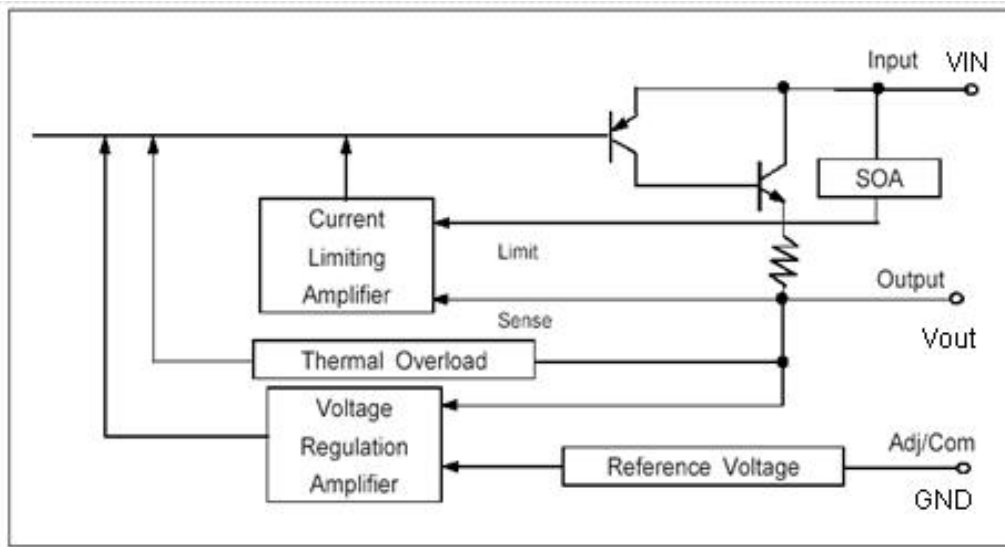

Block Diagram

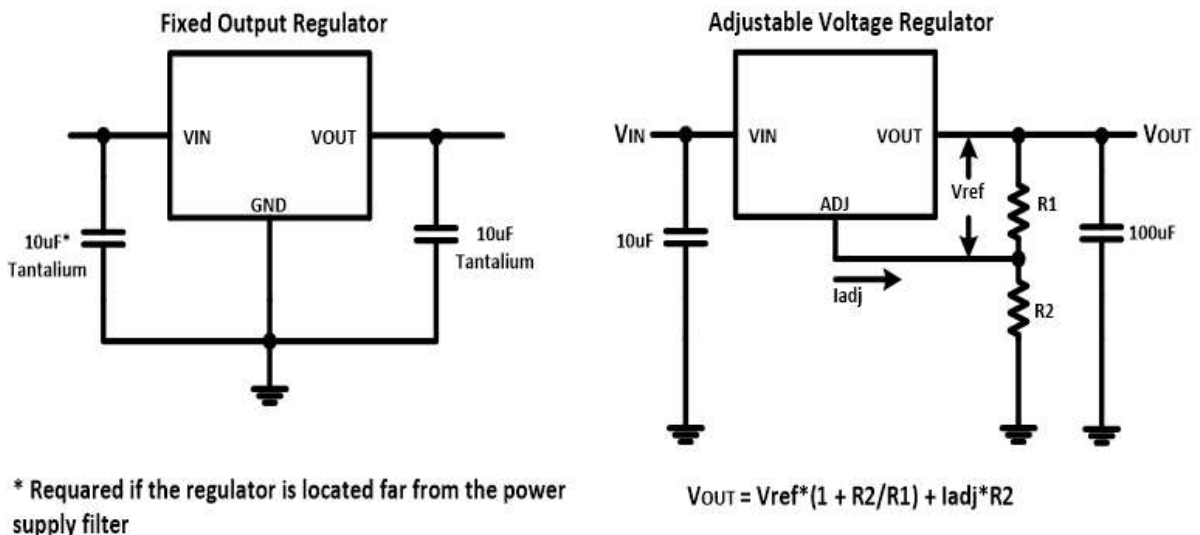

\* Required if the regulator is located far from the power supply filter

Application Schematic

Typical Performances Characteristics

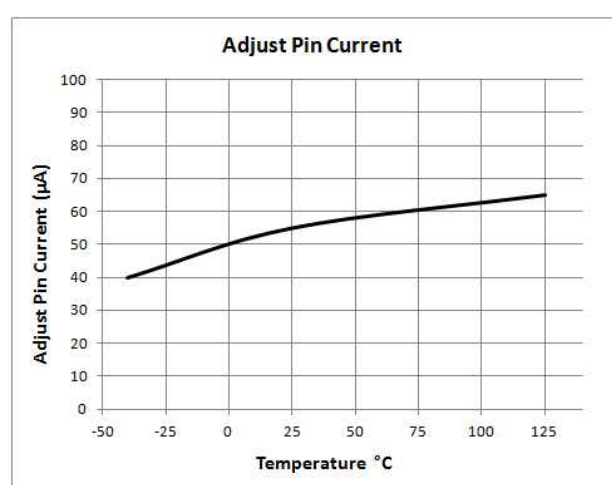
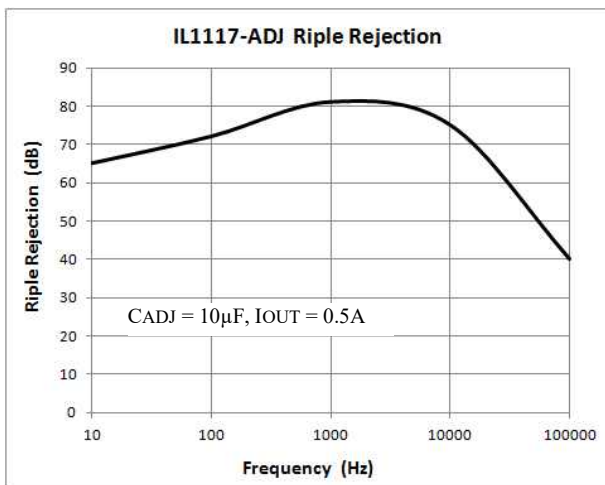
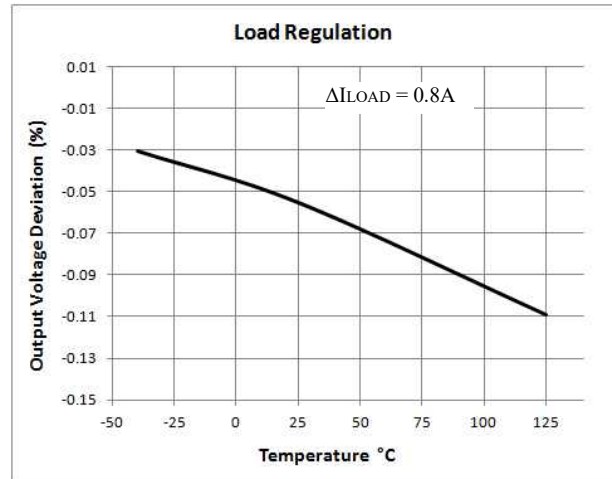
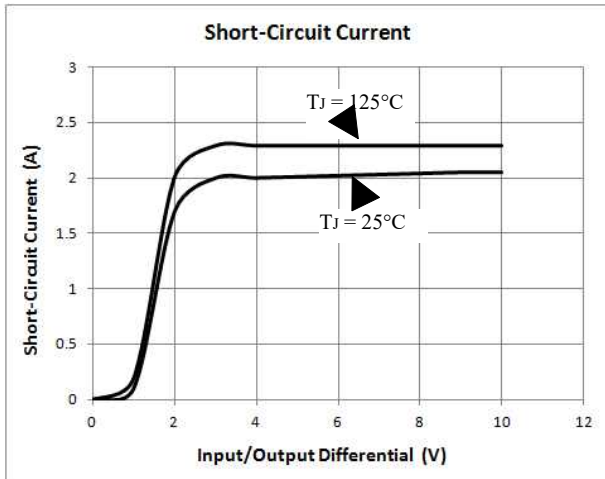
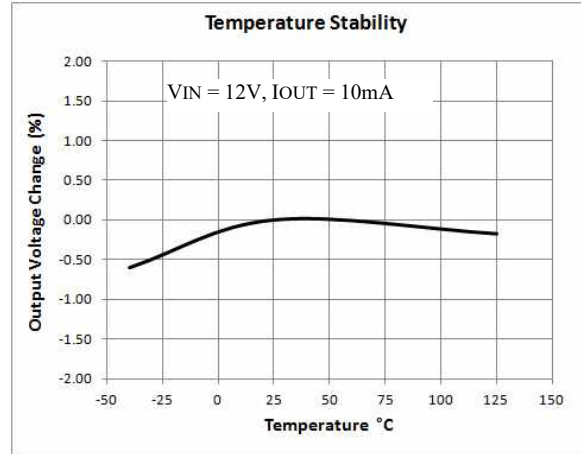
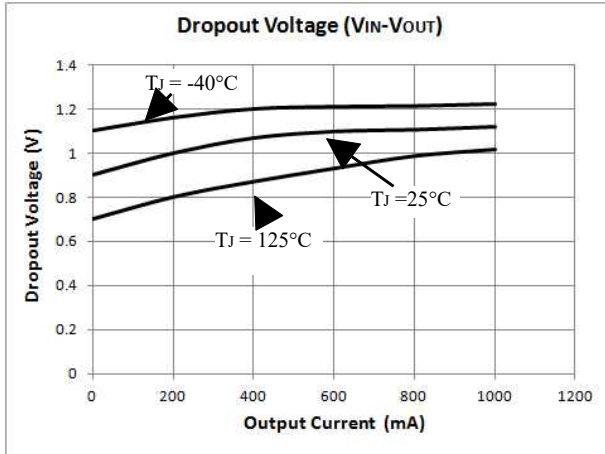

Typical Performance Characteristics (continue)

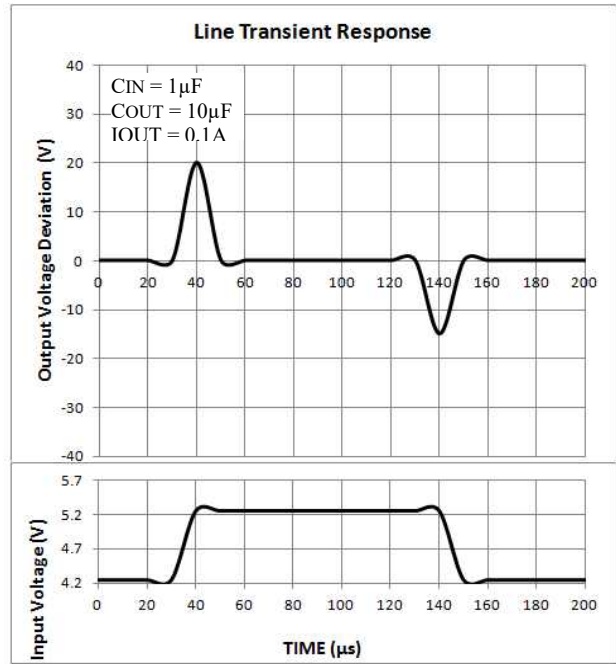
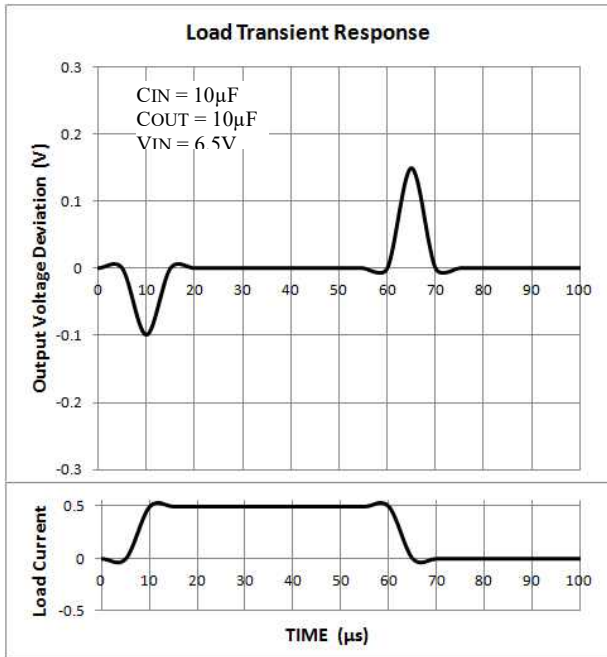

## Application Information

### Output voltage adjustment

Like most regulators, the IL1117C regulates the output by comparing the output voltage to an internally generated reference voltage. On the adjustable version as shown in Fig.4, the  $V_{REF}$  is available externally as 1.25V between  $V_{OUT}$  and ADJ. The voltage ratio formed by R1 and R2 should be set to conduct 10mA (minimum output load).

The output voltage is given by the following equation:

$$V_{OUT} = V_{REF} \cdot (1 + R2/R1) + I_{ADJ} \cdot R2$$

On fixed versions of IL1117C, the voltage divider is provided internally.

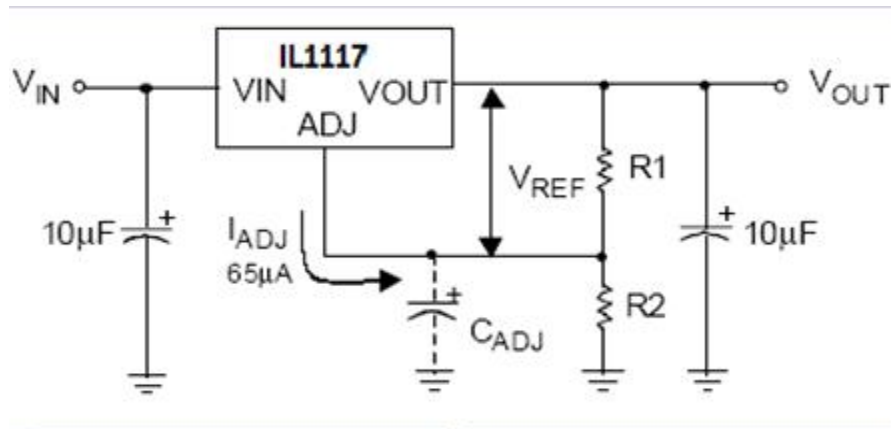

Fig.4. Basic Adjustable Regulator

### Input Bypass Capacitor

An input capacitor is recommended. A 10µF tantalum on the input is a suitable input bypassing for almost all applications.

### Adjust Terminal Bypass Capacitor

The adjust terminal can be bypassed to ground with a bypass capacitor ( $C_{ADJ}$ ) to improve ripple rejection. This bypass capacitor prevents ripple from being amplified as the output voltage is increased. At any ripple frequency, the impedance of the  $C_{ADJ}$  should be less than R1 to prevent the ripple from being amplified:

$$1 / (2\pi \cdot f_{RIPPLE} \cdot C_{ADJ}) < R1$$

The R1 is the resistor between the output and the adjust pin. Its value is normally in the range of 100- 200Ω. For example, with  $R1 = 124\Omega$  and  $f_{RIPPLE} = 120\text{Hz}$ , the  $C_{ADJ}$  should be  $> 11\mu\text{F}$ .

### Output Capacitor

IL1117C requires a capacitor from  $V_{OUT}$  to GND to provide compensation feedback to the internal gain stage. This is to ensure stability at the output terminal. Typically, 10µF tantalum or 50µF aluminum electrolytic is sufficient.

Note: The ESR is typically 1.0 Ω.

The output capacitor does not have a theoretical upper limit and increasing its value will increase stability.  $C_{OUT} = 100\mu\text{F}$  or more is typical for high current regulator design.

### Load Regulation

When the adjustable regulator is used (Fig.5), the best load regulation is accomplished when the top of the resistor divider (R1) is connected directly to the output pin of the IL1117S. When so connected,  $R_P$  is not multiplied by the divider ratio. For Fixed output version, the top of R1 is internally connected to the output and ground pins can be connected to low side of the load.

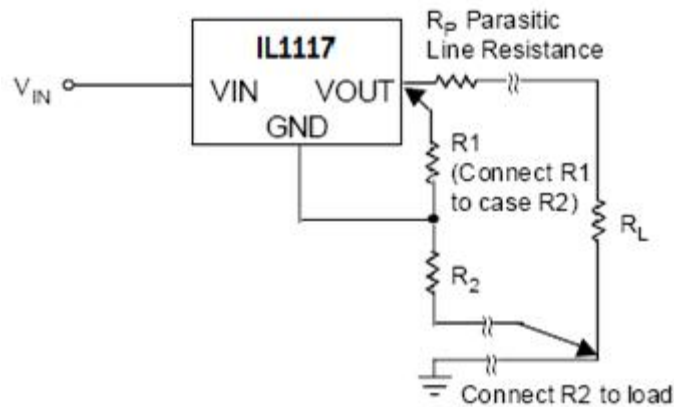

Fig.5. Best Load Regulation Using Adjustable Output Regulator

**Thermal Protection**

IL1117C has thermal protection which limits junction temperature to 150°C. However, device functionality is only guaranteed to a maximum junction temperature of +125°C. The power dissipation and junction temperature for IL1117S in package are given by

$$P_D = (V_{IN} - V_{OUT}) \times I_{OUT}$$

$$T_{JUNCTION} = T_{AMBIENT} + (P_D \times \theta_{JA})$$

Note: T<sub>J</sub> must not exceed 125°C

**Current Limit Protection**

IL1117C is protected against overload conditions. Current protection is triggered at typically 1.8A.

**Thermal Consideration**

The IL1117C series contain thermal limiting circuitry designed to protect itself from over-temperature conditions. Even for normal load conditions, maximum junction temperature ratings must not be exceeded. As mention in thermal protection section, we need to consider all sources of thermal resistance between junction and ambient. It includes junction-to-case, case-to-heat-sink interface, and heat sink thermal resistance itself.

Junction-to-case thermal resistance is specified from the IC junction to the bottom of the case directly below the die. Proper mounting is required to ensure the best possible thermal flow from this area of the package to the heat sink. The case of all devices in this series is electrically connected to the output. Therefore, if the case of the device must be electrically isolated, a thermally conductive spacer is recommended.

**Heatsink Requirements**

The IL1117C series have internal thermal shutdown to protect the device from over-heat. Under all possible operating conditions, the junction temperature must be within the range of 0°C to 125°C. A heatsink may be required depending on the maximum power dissipation and maximum ambient temperature of the application. To determine if a heatsink is needed, the power dissipated by the regulator, P<sub>D</sub>, must be calculated:

$$I_{IN} = I_L + I_G$$

$$P_D = (V_{IN} - V_{OUT}) \times I_L + V_{IN} \times I_G$$

The next parameter which must be calculated is the maximum allowable temperature rise, T<sub>R(MAX)</sub>:

$$T_{R(MAX)} = T_{J(MAX)} - T_{A(MAX)}$$

Where T<sub>J(MAX)</sub> is the maximum allowable junction temperature (125°C), and T<sub>A(MAX)</sub> is the maximum ambient temperature which will be encountered in the application.

Using the calculated values for T<sub>R(MAX)</sub> and P<sub>D</sub>, the maximum allowable value for the junction-to ambient thermal resistance (θ<sub>JA</sub>) can be calculated:

$$\theta_{JA} = T_{R(MAX)} / P_D$$

If the maximum allowable value for  $\Theta_{JA}$  is found to be  $\geq 170^{\circ}\text{C/W}$  for SOT-223 package or  $\geq 115^{\circ}\text{C/W}$  for TO-252 package or  $\geq 250^{\circ}\text{C/W}$  for SO-89 package, no heat sink is needed since the package alone will dissipate enough heat to satisfy these requirements. If the calculated value for  $\Theta_{JA}$  falls below these limits, a heatsink is required.

As design aid, Table 1 shows the value of the  $\Theta_{JA}$  of SOT-223, TO-252 and SOT-89 for different heatsink area. The copper patterns that used to measure these  $\Theta_{JA}$  are shown on the Figure 6.

TABLE1. Thermal Resistance values for different packages and Copper Areas.

PKG	OZ	Thermal Resistance	Copper Area, mm <sup>2</sup>			
			100mm <sup>2</sup>	200mm <sup>2</sup>	300mm <sup>2</sup>	500mm <sup>2</sup>
SOT-223	1OZ	$\Theta_{J-A}$ , $^{\circ}\text{C/W}$	105	72	66	63
	2OZ	$\Theta_{J-A}$ , $^{\circ}\text{C/W}$	95	66	56	50
SOT-89	1OZ	$\Theta_{J-A}$ , $^{\circ}\text{C/W}$	150	92	73	66
	2OZ	$\Theta_{J-A}$ , $^{\circ}\text{C/W}$	120	82	62	57
TO-252	1OZ	$\Theta_{J-A}$ , $^{\circ}\text{C/W}$	80	62	53	43
	2OZ	$\Theta_{J-A}$ , $^{\circ}\text{C/W}$	69	53	42	36

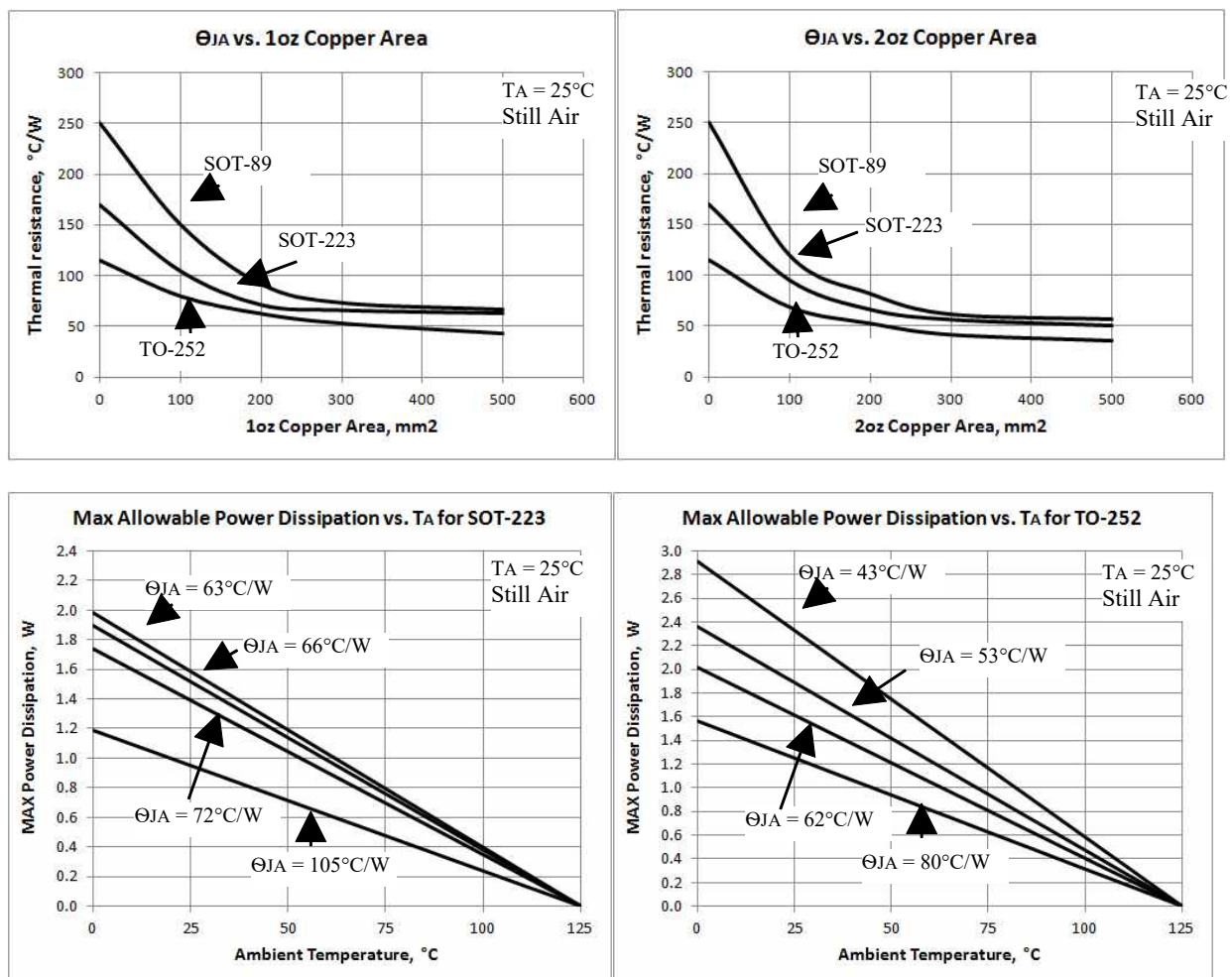

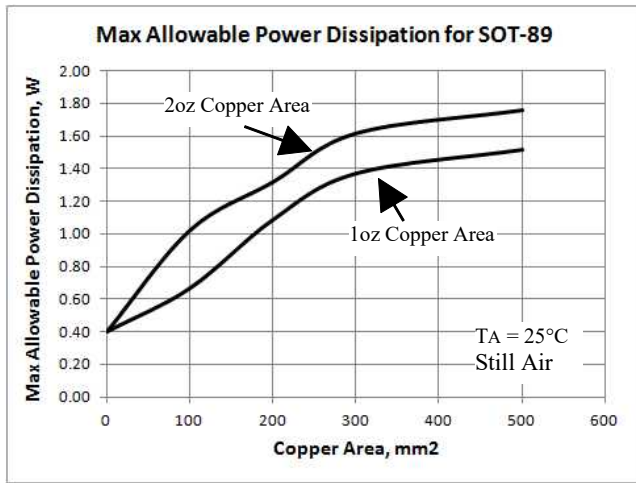
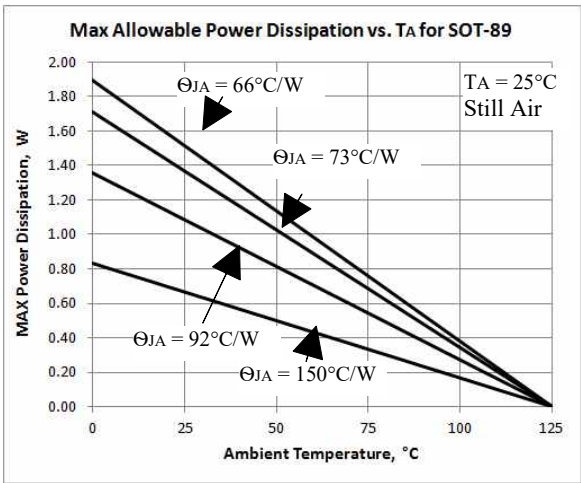
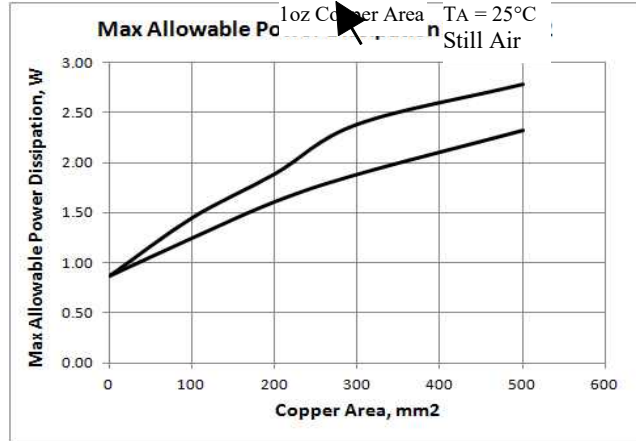
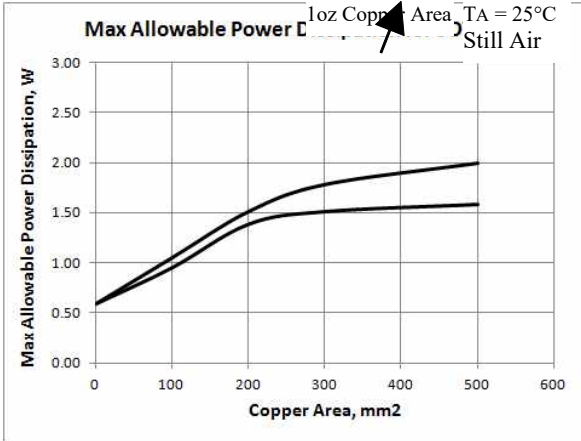

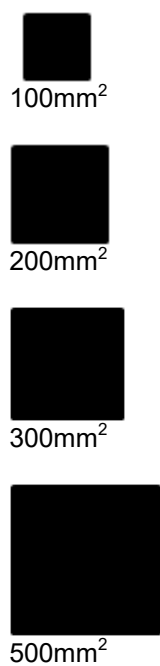
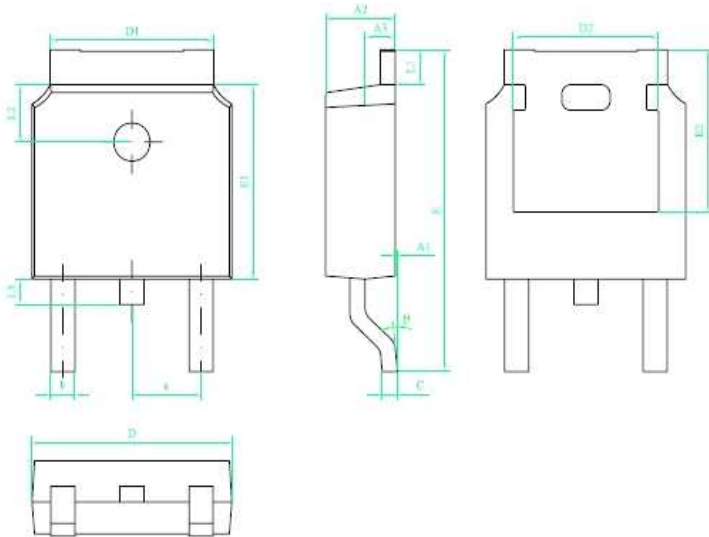

Fig.6. Top View of the Thermal Test Pattern in Actual Scale

Package Dimensions

TO-252-3L Package



Symbol	Dimension in Millimeters		
	Min	Typ	Max
A1	0.00		0.10
A2	2.20	2.30	2.40
A3	0.90	1.00	1.10
b	0.75		0.85
c	0.50		0.60
D	6.50	6.60	6.70
D1	5.30	5.40	5.50
D2	4.70	4.80	4.90
E	9.90	10.10	10.30
E1	6.00	6.10	6.20
E2	5.20	5.30	5.40
e	2.20	2.29	2.40
L1	0.90		1.25
L2	1.70	1.80	1.90
L3	0.60	0.80	1.00
⊙	0.00		8.00

SOT-223-3L Package

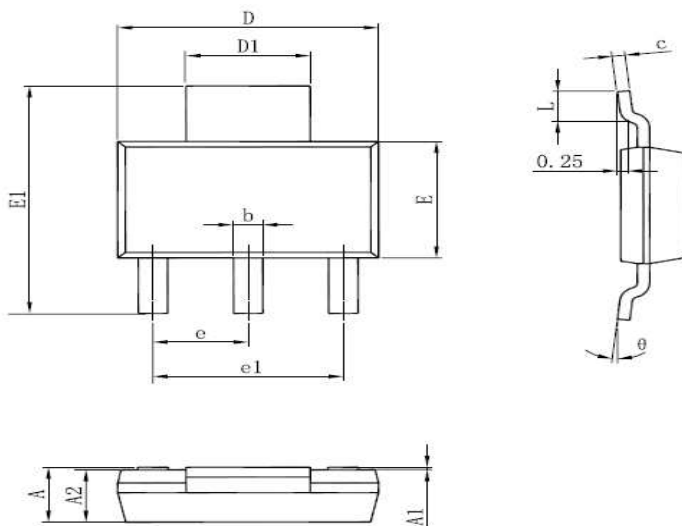

Symbol	Dimension in Millimeters		
	Min	Typ	Max
A	1.52		1.80
A1	0.02		0.10
A2	1.50		1.70
b	0.66		0.81
c	0.24		0.32
D	6.30		6.50
D1	2.90		3.10
E	3.30		3.70
E1	6.83		7.07
e	2.300 (BSC)		
e1	4.50		4.70
L	0.90		1.15
⊙	0.00		10.00

SOT-89-3L Package

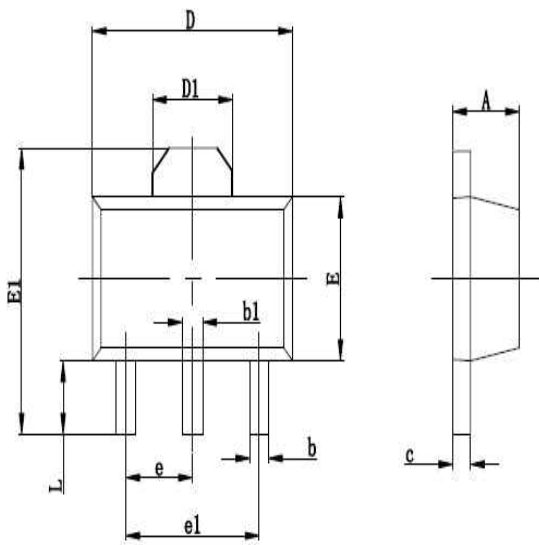

Symbol	Dimension in Millimeters		
	Min	Typ	Max
A	1.40		1.60
b	0.35		0.52
b1	0.40		0.58
c	0.35		0.44
D	4.40		4.60
D1	1.550REF		
E	2.35		2.55
E1	3.94		4.25
e	1.500 (BSC)		
e1	3.000 (BSC)		
⊙	0.90		1.10