

iC-HG

3 A LASER SWITCH



Rev B1, Page 1/20

FEATURES

- Six channel laser switch from CW up to 200 MHz
- CW operation with up to 500 mA per channel
- Pulsed operation with up to 1.5 A per channel
- Spike-free switching of the laser current
- 6 x 1 channels with TTL inputs
- 3 x 2 channels with LVDS inputs
- Operates as six independent voltage-controlled current sinks
- Outputs (LDKx) are 12 V capable for blue/green laser diodes
- Fast and slow switching mode
- Simple current control at pins Clx
- Clx voltage < 3 V for full CW current
- Wide supply voltage range from 3 to 5.5 V
- All channels can be paralleled for up to 3 A CW and 9 A pulsed operation
- Multiple iC-HG can be connected in parallel for higher currents
- Open drain error output
- Thermal shutdown

APPLICATIONS

- Pump lasers
- Laser projection
- Laser TV
- Data transmission
- TOF camera lighting

PACKAGES

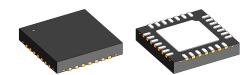

QFN28 5 mm x 5 mm

BLOCK DIAGRAM

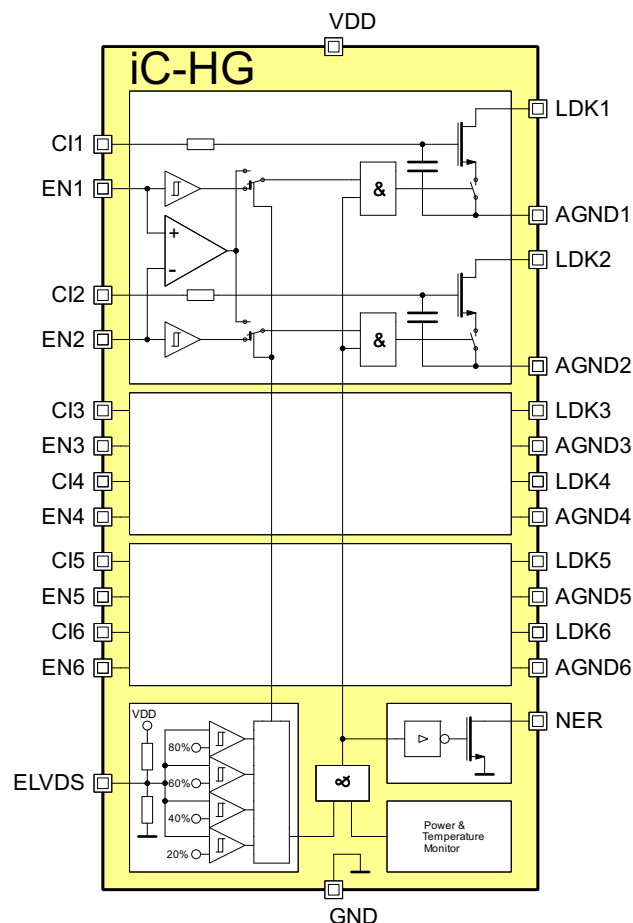

iC-HG

3 A LASER SWITCH



Rev B1, Page 2/20

DESCRIPTION

Six channel Laser Switch iC-HG enables the spike-free switching of laser diodes with well-defined current pulses at frequencies ranging from DC to 200 MHz.

The diode current is determined by the voltages at pins Clx.

The six fast switches are controlled independently via TTL inputs. Input ELVDS = hi selects LVDS type inputs and three channel mode. *TTL slow switch mode* is selected with 30% VDD and *LVDS slow switch mode* with 70% VDD at input ELVDS.

The laser diode can thus be turned on and off or switched between different current levels (LDKx connected) defined by the voltages at Clx.

Each channel can be operated up to 500 mA CW and 1500 mA pulsed current depending on the frequency, duty cycle and heat dissipation.

The integrated thermal shutdown feature protects the iC-HG from damage by excessive temperature.

PACKAGING INFORMATION QFN28 5 mm x 5 mm to JEDEC

PIN CONFIGURATION QFN28 5 mm x 5 mm

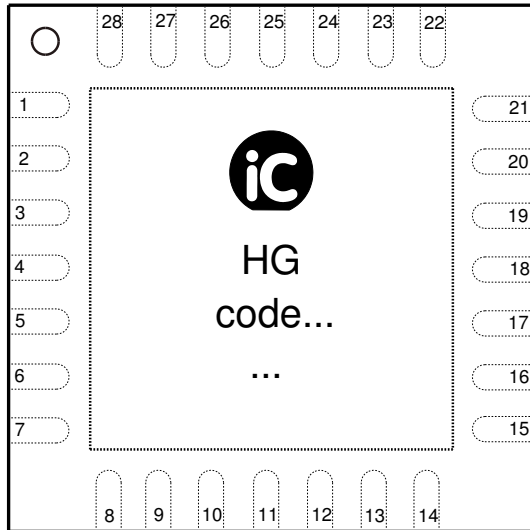

PIN FUNCTIONS

No.	Name	Function
1	CI1	Current control voltage channel 1
2	CI2	Current control voltage channel 2
3	CI3	Current control voltage channel 3
4	GND	Ground
5	CI4	Current control voltage channel 4
6	CI5	Current control voltage channel 5
7	CI6	Current control voltage channel 6
8	AGND6	Analog ground channel 6
9	LDK6	Laser diode cathode channel 6
10	AGND5	Analog ground channel 5
11	LDK5	Laser diode cathode channel 5
12	AGND4	Analog ground channel 4
13	LDK4	Laser diode cathode channel 4
14	EN6	TTL switching input channel 6 Negative LVDS Input channel 5 and 6
15	EN5	TTL switching input channel 5 Positive LVDS Input channel 5 and 6
16	EN4	TTL switching input channel 4 Negative LVDS Input channel 3 and 4
17	EN3	TTL switching input channel 3 Positive LVDS Input channel 3 and 4
18	VDD	Supply voltage
19	ELVDS	TTL/LVDS Fast/Slow Input selector
20	EN2	TTL switching input channel 2 Negative LVDS Input channel 1 and 2
21	EN1	TTL switching input channel 1 Positive LVDS Input channel 1 and 2
22	NER	Error monitor output
23	LDK3	Laser diode cathode channel 3
24	AGND3	Analog ground channel 3
25	LDK2	Laser diode cathode channel 2
26	AGND2	Analog ground channel 2
27	LDK1	Laser diode cathode channel 1
28	AGND1	Analog ground channel 1

The *Thermal Pad* is to be connected to a *Ground Plane* (GND, AGND1...6) on the PCB.

Only pin 1 marking on top or bottom defines the package orientation (Ⓢ HG label and coding is subject to change).

PACKAGE DIMENSIONS QFN28-5x5

All dimensions given in mm.
This package falls within JEDEC MO-220-VHHD-1.

RECOMMENDED PCB-FOOTPRINT

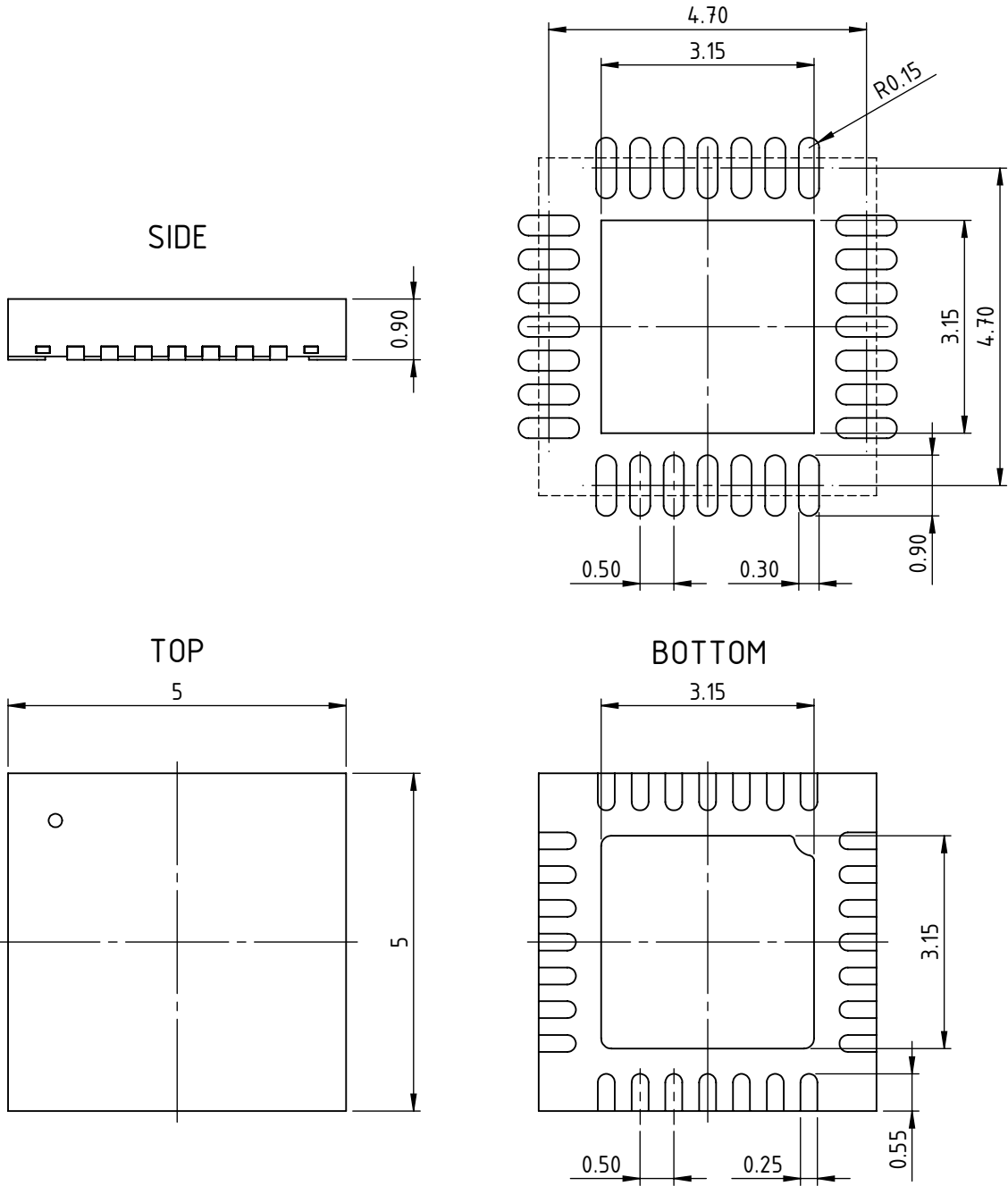

ABSOLUTE MAXIMUM RATINGS

Beyond these values damage may occur; device operation is not guaranteed.

Item No.	Symbol	Parameter	Conditions	Limits		Unit
				Min.	Max.	
G001	VDD	Voltage at VDD		-0.3	6	V
G002	I(VDD)	Current in VDD		-10	750	mA
G003	V(CI)	Voltage at CI1...6		-0.3	6	V
G004	V()	Voltage at EN1...6, AGND1...6, ELVDS, NER		-0.3	6	V
G005	V(LDK)	Voltage at LDK1...6		-0.3	12	V
G006	I(LDK)	Current in LDK1...6	DC current	-10	600	mA
G007	I(AGND)	Current in AGND1...6	DC current	-600	10	mA
G008	I()	Current in CI1...6, EN1...6, ELVDS		-10	10	mA
G009	I(NER)	Current in NER		-10	20	mA
G010	Vd()	ESD Susceptibility at all pins	HBM 100 pF discharged through 1.5 k Ω		2	kV
G011	T _j	Operating Junction Temperature		-40	125	°C
G012	T _s	Storage Temperature Range		-40	150	°C

THERMAL DATA

Item No.	Symbol	Parameter	Conditions	Limits			Unit
				Min.	Typ.	Max.	
T01	T _a	Operating Ambient Temperature Range (extended range on request)		-25		85	°C
T02	R _{thja}	Thermal Resistance Chip/Ambient	Mounted onto the Evaluation Board HG1D		25		K/W
T03	R _{thjTP}	Thermal Resistance Chip/Thermal Pad			4		K/W

All voltages are referenced to ground unless otherwise stated.

All currents flowing into the device pins are positive; all currents flowing out of the device pins are negative.

ELECTRICAL CHARACTERISTICS

Operating Conditions: VDD = 3.0...5.5 V, AGND1...6 = GND, Tj = -40...125 °C unless otherwise stated

Item No.	Symbol	Parameter	Conditions				Unit
				Min.	Typ.	Max.	
Total Device (x = 1...6)							
001	VDD	Permissible Supply Voltage		3		5.5	V
002	I(VDD)	Supply Current in VDD	CW operation			10	mA
003	I(VDD)	Supply Current in VDD	pulsed operation, f(ENx) = 200 MHz			700	mA
004	V(LDKx)	Permissible Voltage at LDKx		-0.3		12	V
005	V(NER)	Permissible Voltage at NER		-0.3		5.5	V
006	Vc(hi)	Clamp Voltage hi at LDKx	I(LDK) = 10 mA	12.1		18	V
007	Vc(NER)	Clamp Voltage hi at NER	I(NER) = 1 mA	7	15	18	V
008	Vc(Clx)hi	Clamp Voltage hi at Clx	Vc(Clx) = V(Clx) – VDD; I(CI) = 10 mA, other pins open	0.3		1.6	V
009	Vc(hi)	Clamp Voltage hi at ENx, ELVDS	Vc() = V() – VDD; I() = 1 mA, other pins open	0.8		3	V
010	Vc(lo)	Clamp Voltage lo at VDD, LDKx, Clx, ENx, AGNDx, ELVDS, NER	I() = -10 mA, other pins open	-1.6		-0.3	V
Laser Control LDK1...6, Cl1...6 (x = 1...6)							
101	Icw(LDKx)	Permissible CW Current in LDKx (per channel)				500	mA
102	Vs(LDKx)	Saturation Voltage at LDKx	I(LDKx) = 450 mA, V(Clx) = V(Clx)@I(LDKx) = 500 mA			1.5	V
103	I0(LDKx)	Leakage Current in LDKx	ENx = lo, V(LDKx) = 12 V			100	µA
104	tr()	LDKx Current Rise Time Fast	Iop(LDKx) = 500 mA, I(LDKx): 10% → 90% Iop, V(ELVDS) = 0 V or VDD			1	ns
105	tf()	LDKx Current Fall Time Fast	Iop(LDKx) = 500 mA, I(LDKx): 90% → 10% Iop, V(ELVDS) = 0 V or VDD			1	ns
106	tr()	LDKx Current Rise Time Slow	Iop(LDKx) = 500 mA, I(LDKx): 10% → 90% Iop, V(ELVDS) = 30% VDD or 70% VDD, VDD = 5 V	5	10	40	ns
107	tf()	LDKx Current Fall Time Slow	Iop(LDKx) = 500 mA, I(LDKx): 90% → 10% Iop, V(ELVDS) = 30% VDD or 70% VDD, VDD = 5 V	5	10	40	ns
108	tr()	LDKx Current Rise Time Slow	Iop(LDKx) = 500 mA, I(LDKx): 10% → 90% Iop, V(ELVDS) = 30% VDD or 70% VDD, VDD = 3.3 V	10	30	90	ns
109	tf()	LDKx Current Fall Time Slow	Iop(LDKx) = 500 mA, I(LDKx): 90% → 10% Iop, V(ELVDS) = 30% VDD or 70% VDD, VDD = 3.3 V	10	30	90	ns
110	tp()	Propagation Delay Fast V(ENx) → I(LDKx)	V(ELVDS) = 0 V or VDD, Differential LVDS Rise and Fall Time < 0.5 ns	3	5	14	ns
111	CR()	Current Matching all Channels		0.9		1.1	
112	V(Clx)	Permissible Voltage at Clx		-0.3		VDD	V
113	Vt(Clx)	Threshold Voltage at Clx	I(LDKx) < 5 mA	0.5		1.2	V
114	V(Clx)	Operating Voltage at Clx	I(LDKx) = 500 mA, V(LDKx) > 1.8 V		2	2.9	V
115	Ipd(Clx)	Pull-Down Current at Clx	V(Clx) = 0.5...5.5 V	1	2.5	5	µA
116	C(Clx)	Capacity at Clx	V(Clx) = 2 V	500	635	760	pF
117	Vc(LDKx)	Clamp Voltage at LDKx	I(LDKx) = 100 mA, tclamp < 1 ms, tclamp/T < 1:100	12.5		20	V
118	tskc()	Channel to Channel Skew				160*	ps
119	tskp()	Part to Part Skew	best to worst			4*	ns
Input EN1...6 (x = 1...6)							
201	Vt(TTL)hi	Input Threshold Voltage hi	V(ELVDS) < 35% VDD, TTL			2	V
202	Vt(TTL)lo	Input Threshold Voltage lo	V(ELVDS) < 35% VDD, TTL	0.8			V
203	Vhys(TTL)	Hysteresis	Vhys() = Vt(hi) – Vt(lo); V(ELVDS) < 35% VDD, TTL	50			mV
204	I(ENx)	Pulldown Current	V(ELVDS) < 35% VDD, V() = 0.8 V...VDD, TTL	4	30	80	µA

* Projected values by simulation

ELECTRICAL CHARACTERISTICS

Operating Conditions: VDD = 3.0...5.5 V, AGND1...6 = GND, Tj = -40...125 °C unless otherwise stated

Item No.	Symbol	Parameter	Conditions	Min.	Typ.	Max.	Unit
205	R(ENx)	Differential Input Impedance at ENx	V(ELVDS) > 65% VDD, V(ENx) < VDD – 1.4 V, LVDS	14		28	kΩ
206	Vdiff	Differential Voltage	Vdiff = V(EN1,3,5) – V(EN2,4,6) ; V(ELVDS) > 65% VDD, LVDS	200			mV
207	V()	Input Voltage Range	V(ELVDS) > 65% VDD, LVDS	0.6		VDD – 1.4	V
Input ELVDS							
301	V(ELVDS)	Voltage at ELVDS	ELVDS open	48	50	52	%VDD
302	Ri(ELVDS)			35	50	70	kΩ
303	Vt(ELVDS)	Threshold Voltage TTL Fast to TTL Slow		16	20	24	%VDD
304	Vt(ELVDS)	Threshold Voltage TTL Slow to Error		36	40	44	%VDD
305	Vt(ELVDS)	Threshold Voltage Error to LVDS Slow		56	60	64	%VDD
306	Vt(ELVDS)	Threshold Voltage LVDS Slow to LVDS Fast		74	80	84	%VDD
307	Vhys()	Hysteresis		10	25	50	mV
Output NER							
401	Vsat(NER)	Saturation Voltage at NER	ELVDS open, I(NER) = 2 mA			0.6	V
402	I(NER)	Current in NER	ELVDS open, V(NER) > 0.6 V	3	9	20	mA
Overtemperature							
501	Toff	Overtemperature Shutdown	rising temperature	130		170	°C
502	Ton	Overtemperature Release	falling temperature	120		160	°C
503	Thys	Hysteresis	Toff – Ton	5			°C
Power On							
601	VON	Power On Voltage VDD	rising voltage			2.9	V
602	VOFF	Power Down Voltage VDD	falling voltage	1.5			V
603	Vhys	Hysteresis		50		500	mV

CONFIGURATION INPUT ELVDS

Pin ELVDS selects between 6 channel TTL mode or 3 channel LVDS mode and chooses slow or fast switching speed. The unconnected pin ELVDS is an error condition signaled at pin NER with the laser current disabled.

Pin ELVDS connected to GND selects the six channel fast TTL mode. Pin ELVDS connected to 30% VDD selects the six channel slow TTL mode. Pin ELVDS

connected to 70% VDD selects the three channel slow LVDS mode. Pin ELVDS connected to VDD selects the three channel fast LVDS mode.

An easy way to set the slow operation mode for TTL and LVDS mode is to connect a voltage divider at pin ELVDS. Figure 1 shows the recommended voltage divider for slow TTL mode and Figure 2 shows the recommended voltage divider for slow LVDS mode.

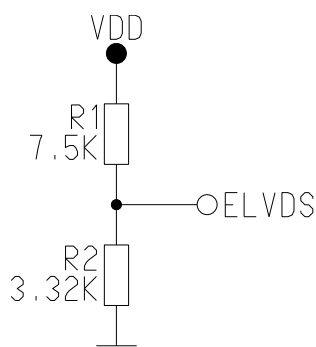

Figure 1: TTL Slow

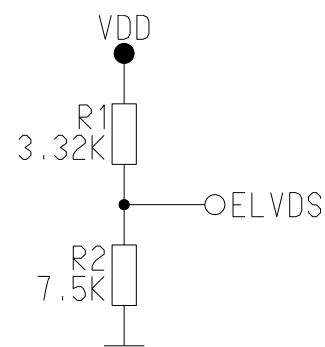

Figure 2: LVDS Slow

DIGITAL INPUTS EN1...6

EN1...6 are the digital switching inputs. With pin ELVDS set to 6 channel TTL mode, each pin ENx enables the current sink at the respective LDKx. With pin ELVDS set to 3 channel LVDS mode, the odd ENx pins are the positive and the even ENx pins are the negative LVDS inputs. EN1 and EN2 control LDK1 and LDK2, EN3 and EN4 control LDK3 and LDK4 and EN5

and EN6 control LDK5 and LDK6. For correct LVDS operation 100Ω terminating resistors between the respective EPx and ENx pins, very close to the inputs, are strongly recommended. Input pins from unused channels have to be connected to GND (TTL operation) resp. EPx to GND and ENx to VDD (LVDS operation).

ANALOG CURRENT CONTROL VOLTAGE INPUTS C11...6

The voltage at pins C11...6 sets the current in pins LDK1...6. Figures 3 and 4 show the temperature dependency of the current in a single LDKx output versus the voltage at C1x for a *typical* device. Figures 5 and

6 show the min., typ. and max. variations between devices at 27 °C temperature. The voltage at pins LDKx is 2.5 V.

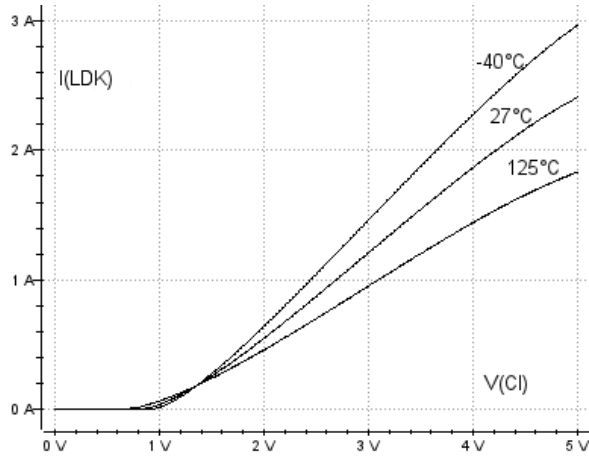

Figure 3: I(LDKx) vs. V(C1x) at VDD = 5 V

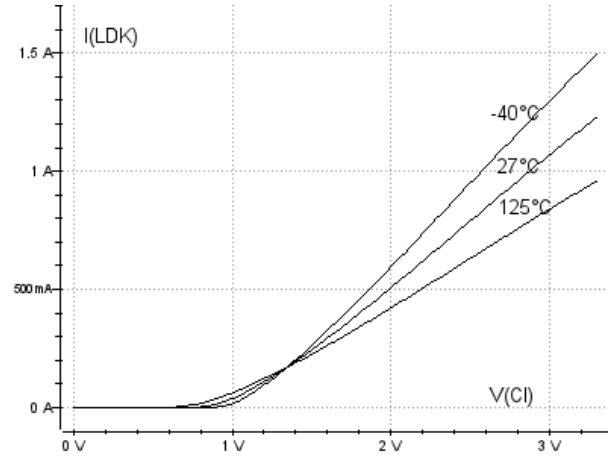

Figure 4: I(LDKx) vs. V(C1x) at VDD = 3.3 V

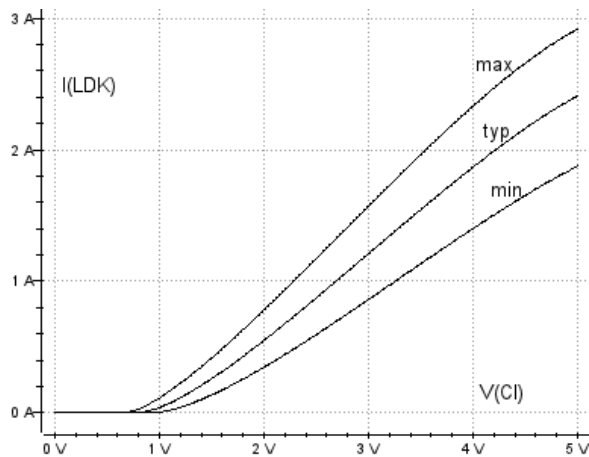

Figure 5: I(LDKx) vs. V(C1x) at VDD = 5 V

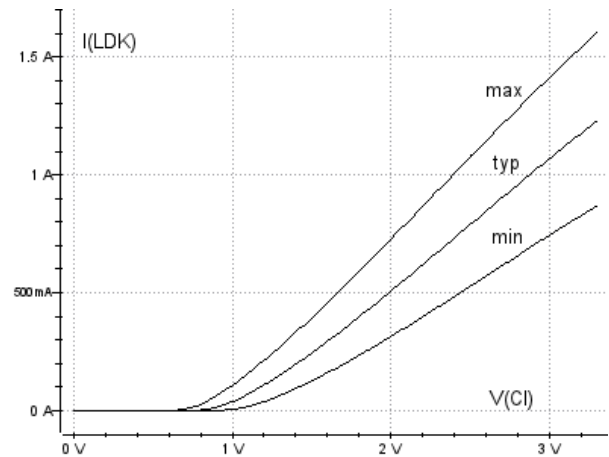

Figure 6: I(LDKx) vs. V(C1x) at VDD = 3.3 V

LASER OUTPUTS LDK1...6

LDK1...6 are the current outputs for the laser diode cathode. For high speed operation, connect the laser diode as close as possible to this pins to minimize the inductance. To ensure a high switching speed, it is important to minimise the inductance of the whole current loop (cf. Figure 7, marked red) consisting of iC-HG (pins LDKx and AGNDx), the laser diode (anode and cathode), the backup capacitors as well as the enclosed area. It may still be necessary though to use an R/C snubber network for damping L/C oscillations.

Depending on the residual inductance in the laser current path and the actual laser current, fast free-wheeling diodes from LDKx to VLDA may be required (cf. Figure 8, diode D1) to protect the outputs. The anode of the free-wheeling diode should be close to the to be protected LDKx output and the cathode close to the backup capacitors at VLDA for the free-wheeling current to be dumped into, when switching the respective channel off.

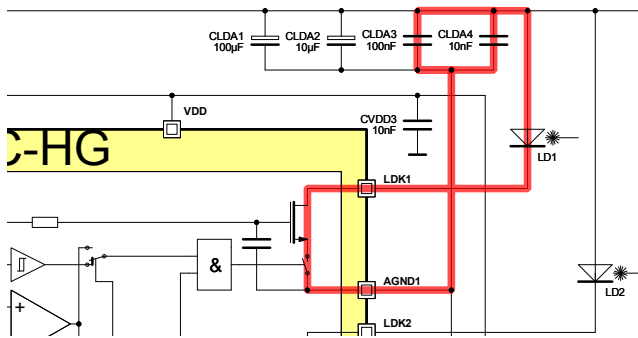

Figure 7: Current loop

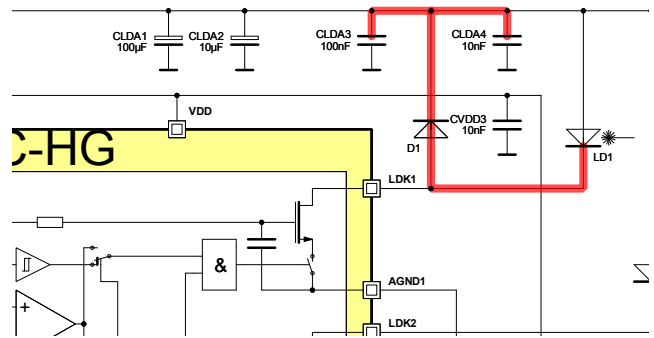

Figure 8: Free-wheeling diode

PULSED OPERATION

The current for pulsed operation may be higher than for CW operation. Therefore the RMS current of the pulse train has to be considered.

With $I_{CW_{max}}$ from Electrical Characteristics No. 101 and pulses $< 10 \mu s$. So for a single channel operated with a 50% duty cycle, the max. laser current becomes

$$I_{pulse_{max}} = I_{CW_{max}} \cdot \sqrt{\frac{repetition\ time(T)}{pulse\ time(t)}} \quad (1)$$

$$I_{pulse_{max}} = 500\ mA \cdot \sqrt{2} = 707\ mA$$

ANALOG GROUNDS AGND1...6

AGND1...6 are the ground pins for the channels. It is recommended to connect all AGND1...6 pins to GND.

ERROR OUTPUT NER

The open drain pin NER is a low-active error output. Signalled errors are ELVDS open or at 50% VDD, VDD undervoltage and thermal shutdown.

THERMAL SHUTDOWN

iC-HG is protected by an integrated thermal shutdown feature. When the shutdown temperature is reached all channels are disabled. Falling temperature after this shutdown will unconditionally enable all channels again. Necessary precaution to prevent damage of the

laser may be to also disable any external control circuits for the laser output power or current control during thermal shutdown. The error signal at pin NER can be used to e.g. disable the control circuit.

APPLICATION EXAMPLES

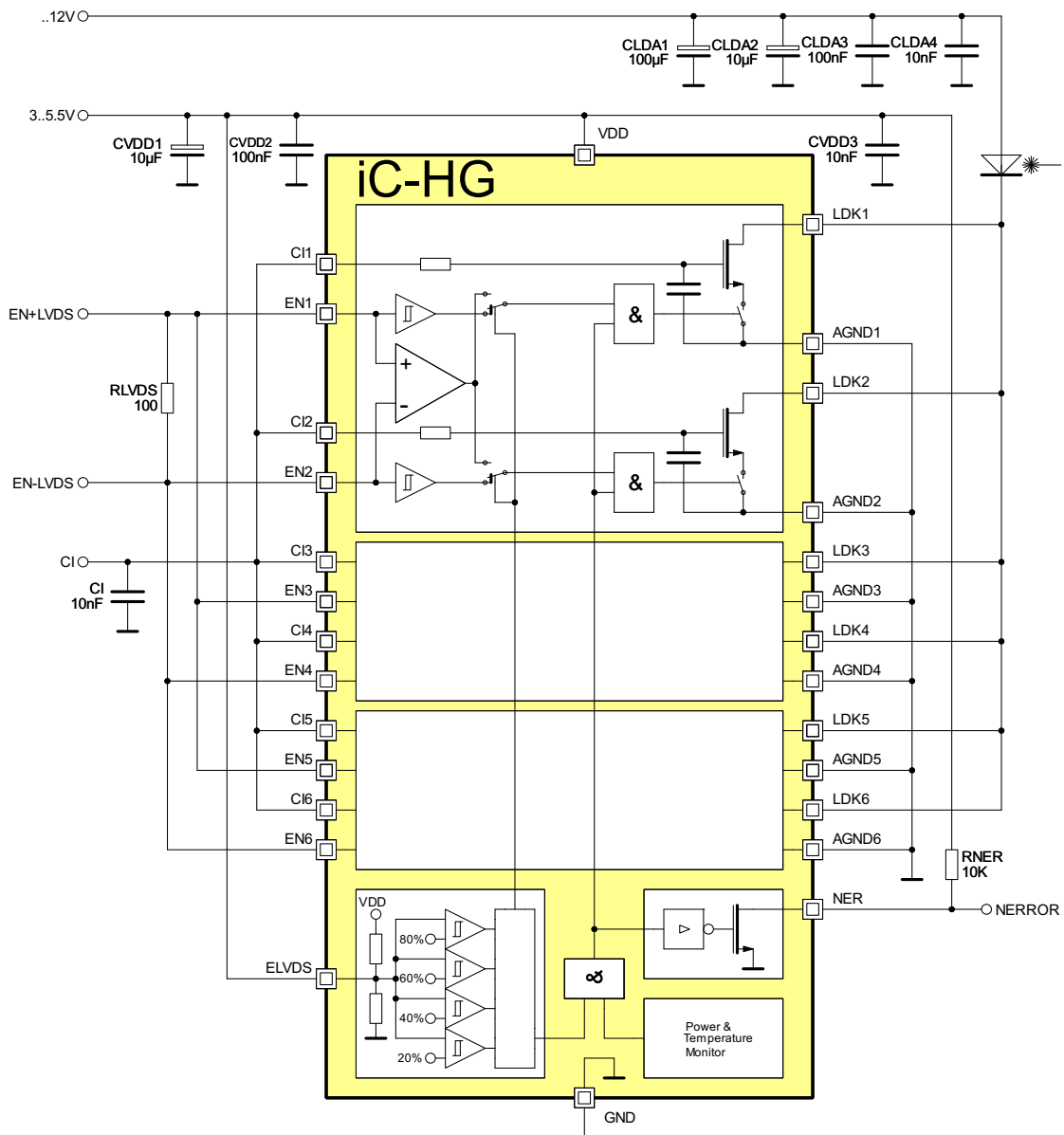

Figure 9: 1 channel LVDS fast

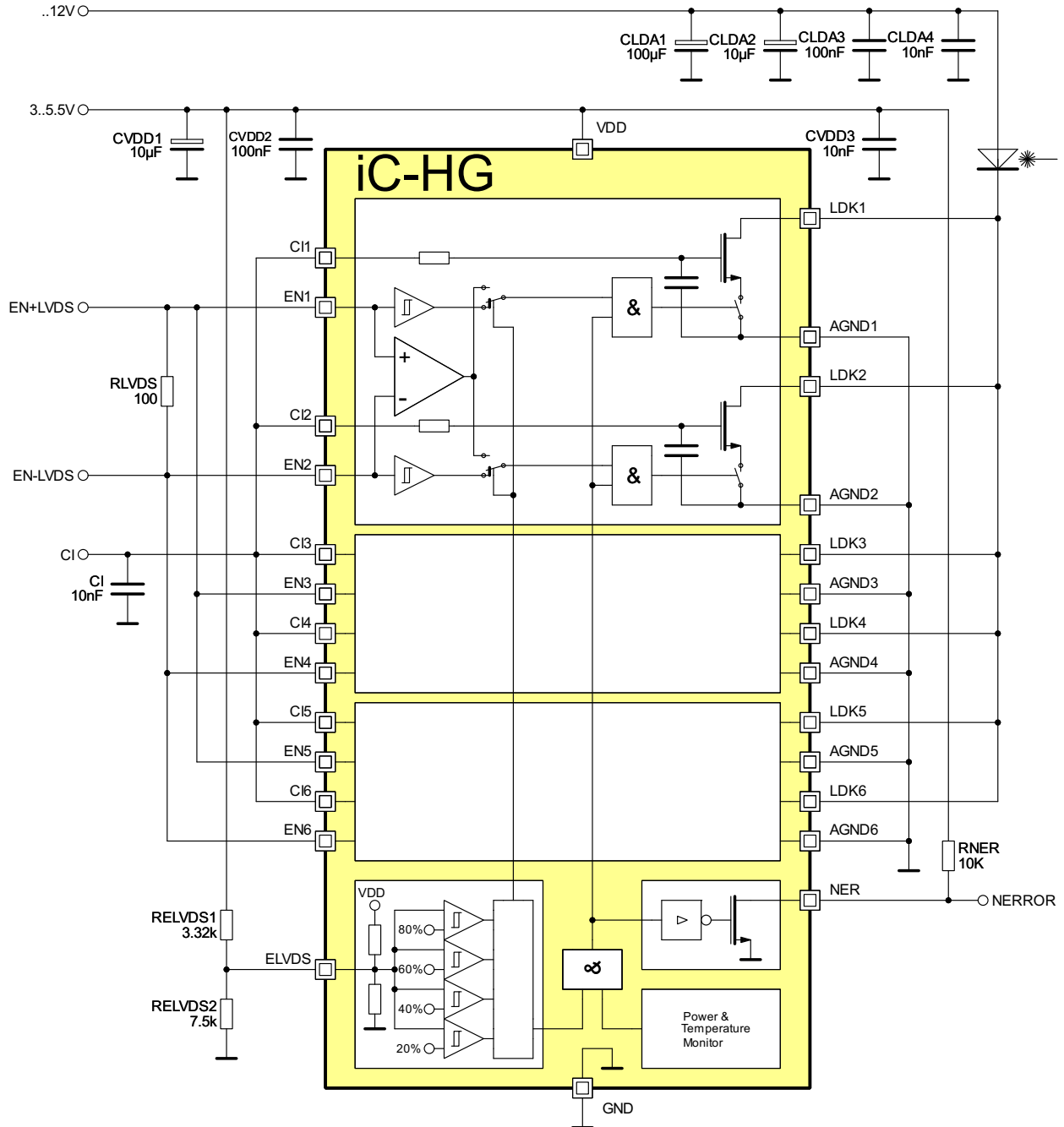

Figure 10: 1 channel LVDS slow

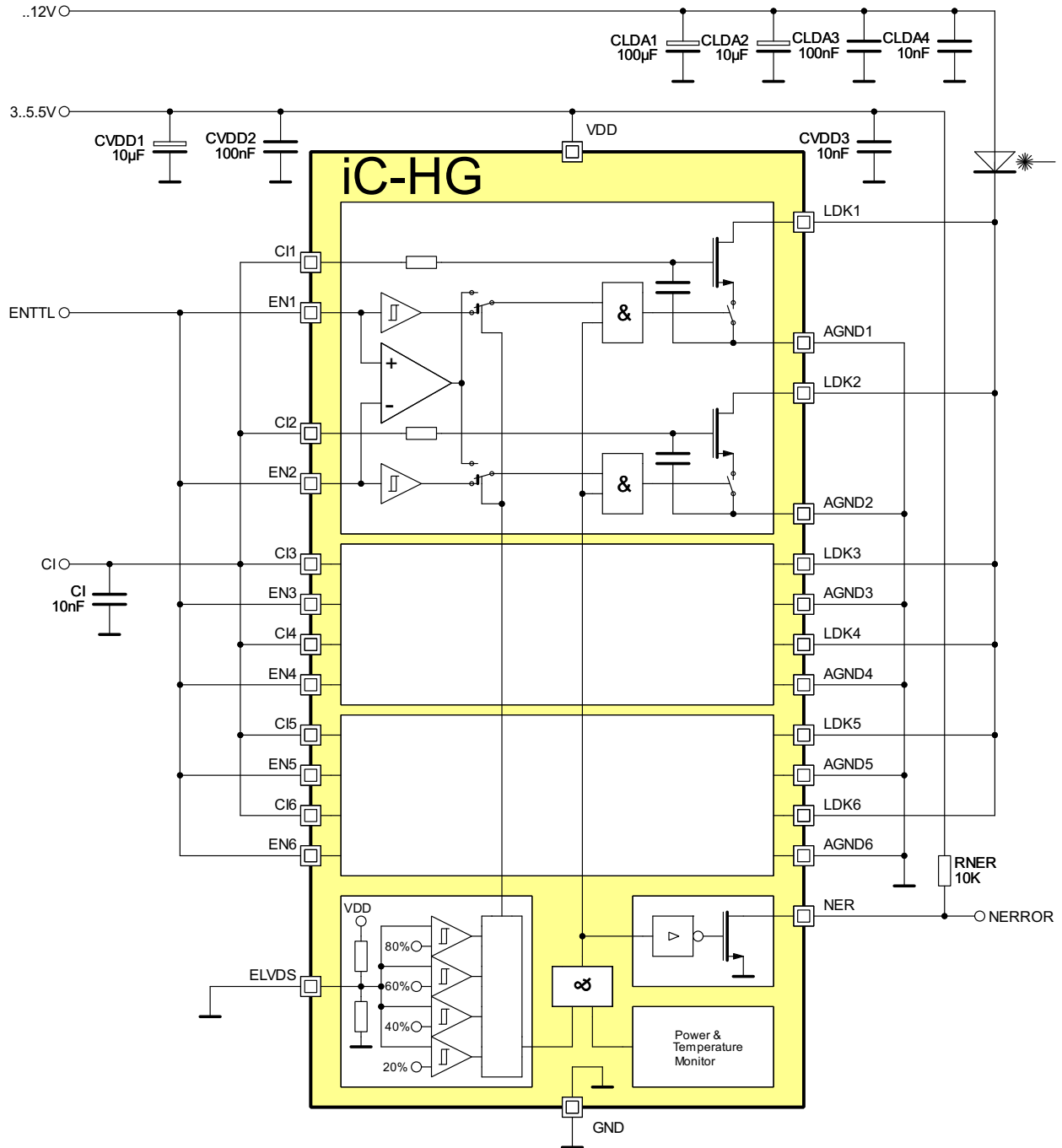

Figure 11: 1 channel TTL fast

iC-HG

3 A LASER SWITCH



Rev B1, Page 14/20

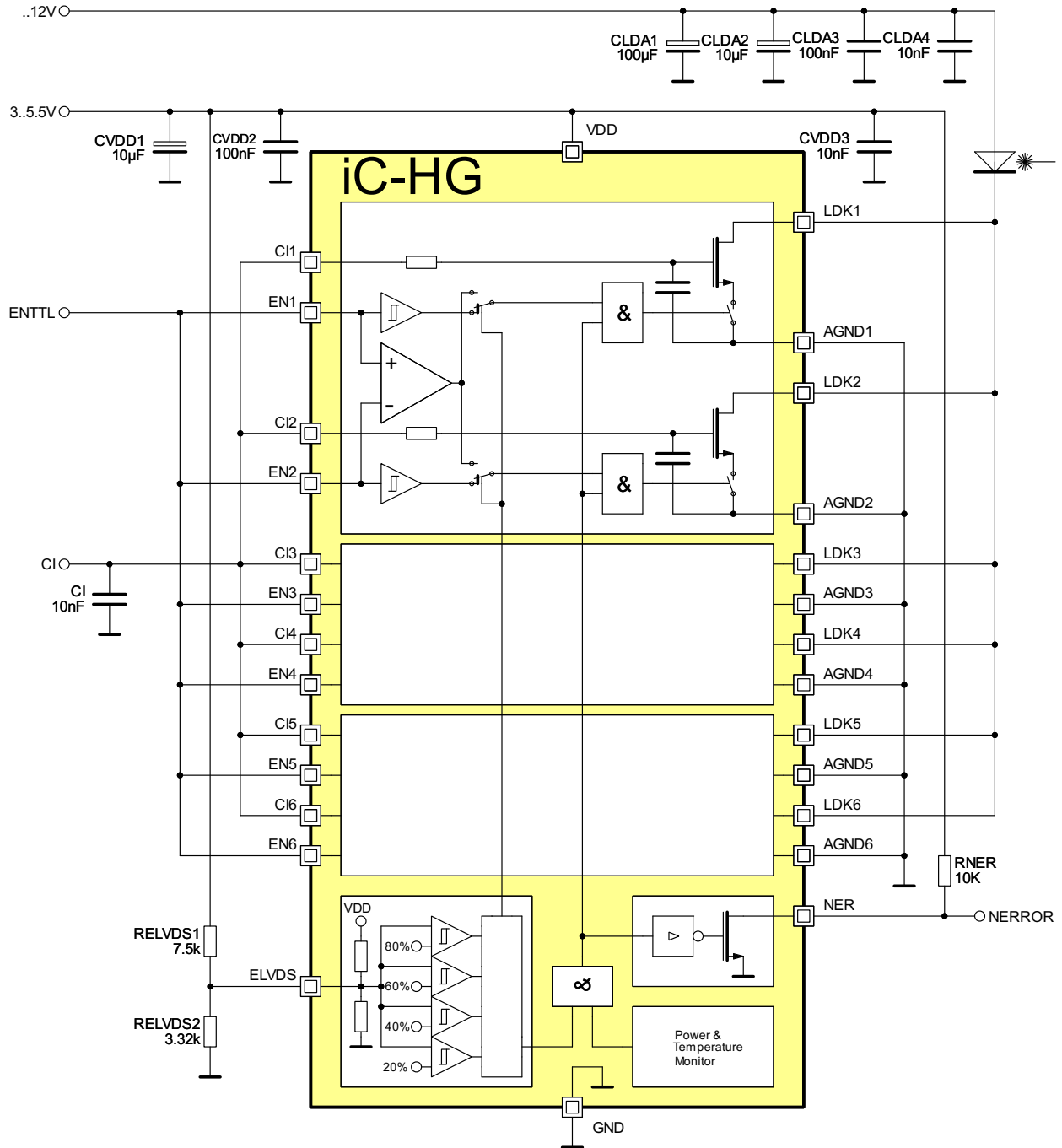

Figure 12: 1 channel TTL slow

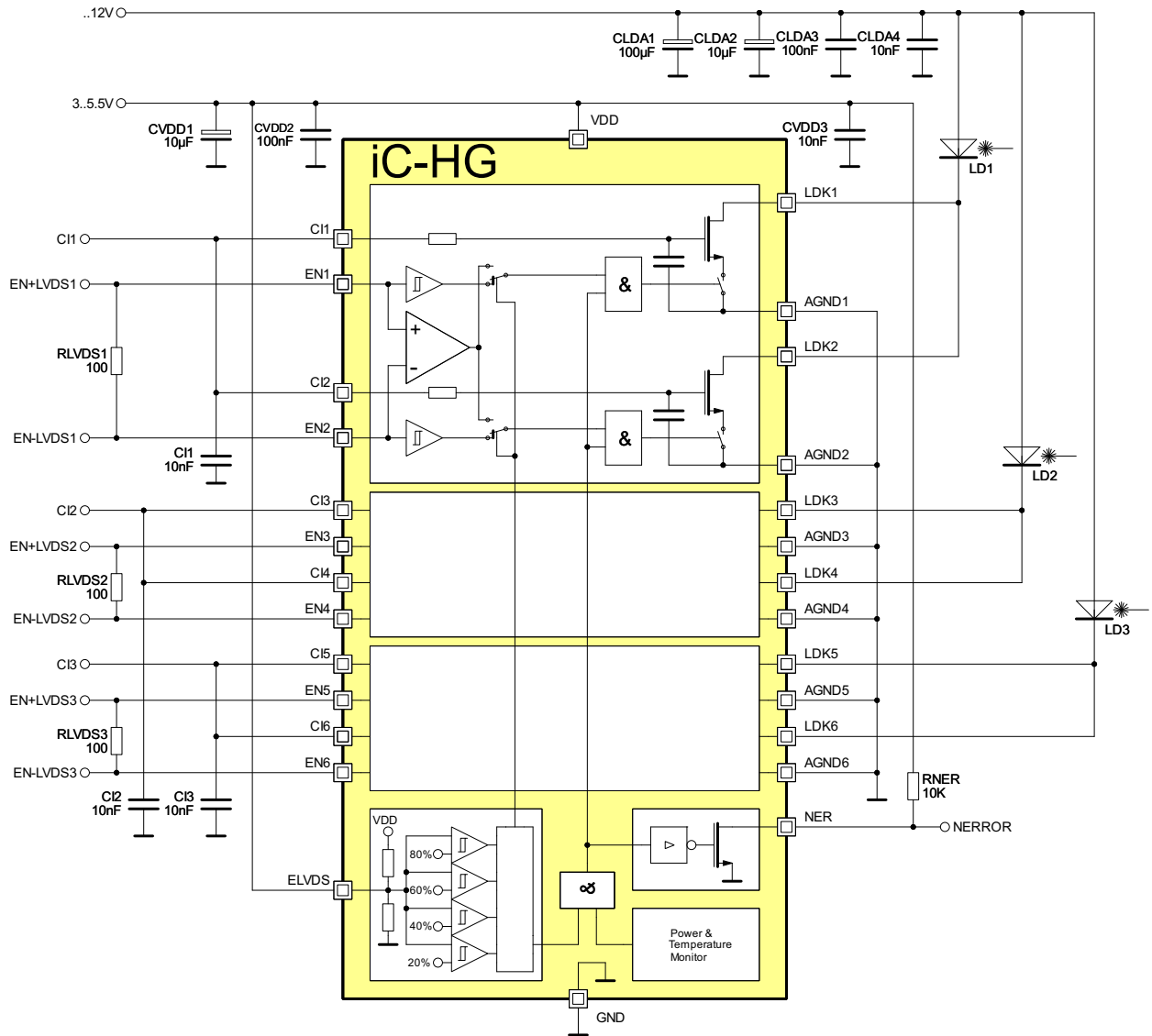

Figure 13: 3 channel LVDS fast

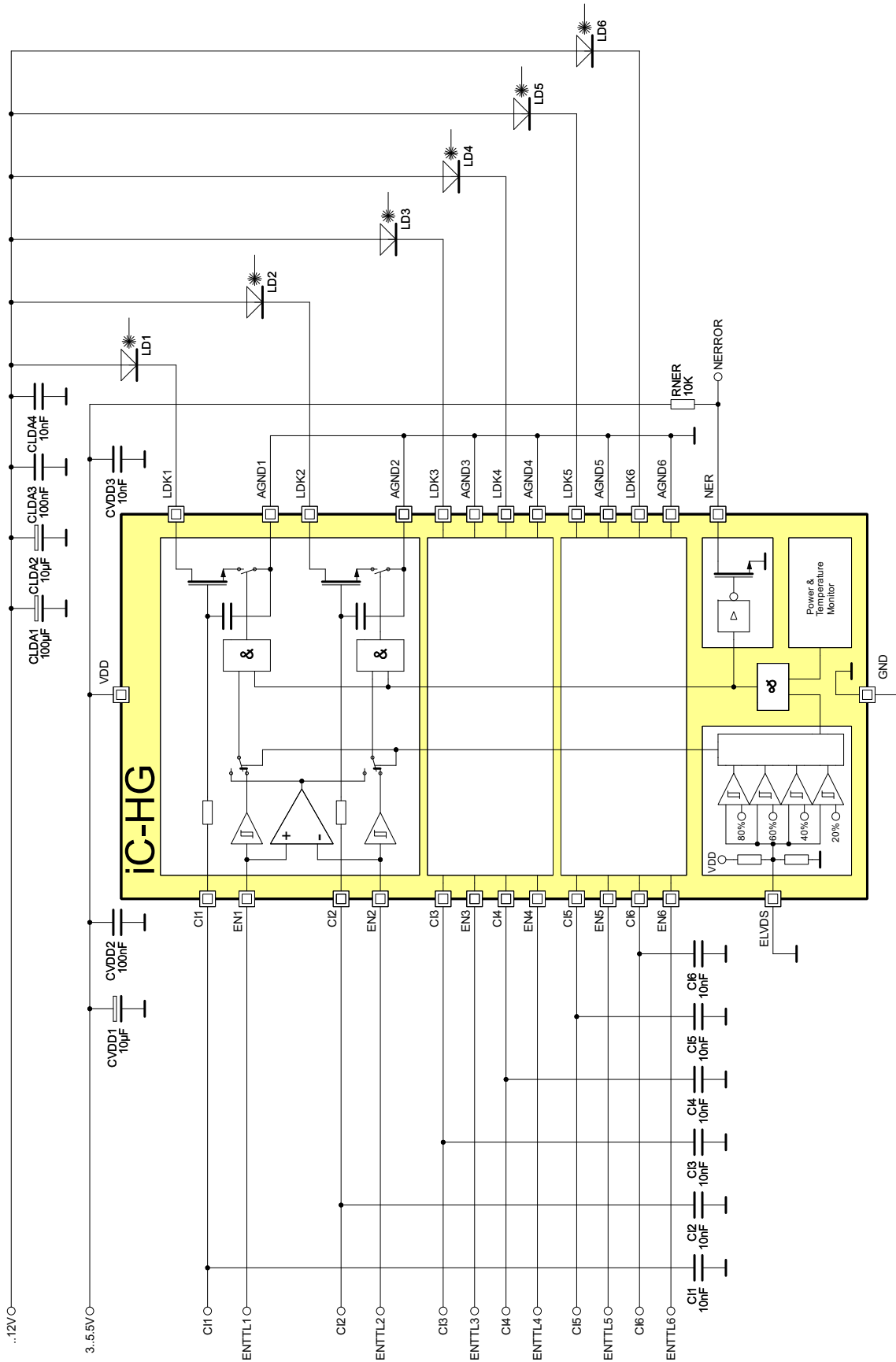

Figure 14: 6 channel TTL fast

EVALUATION BOARD

iC-HG comes with an evaluation board for test purpose. Figures 15 and 16 show both the schematic and the component side of the evaluation board.

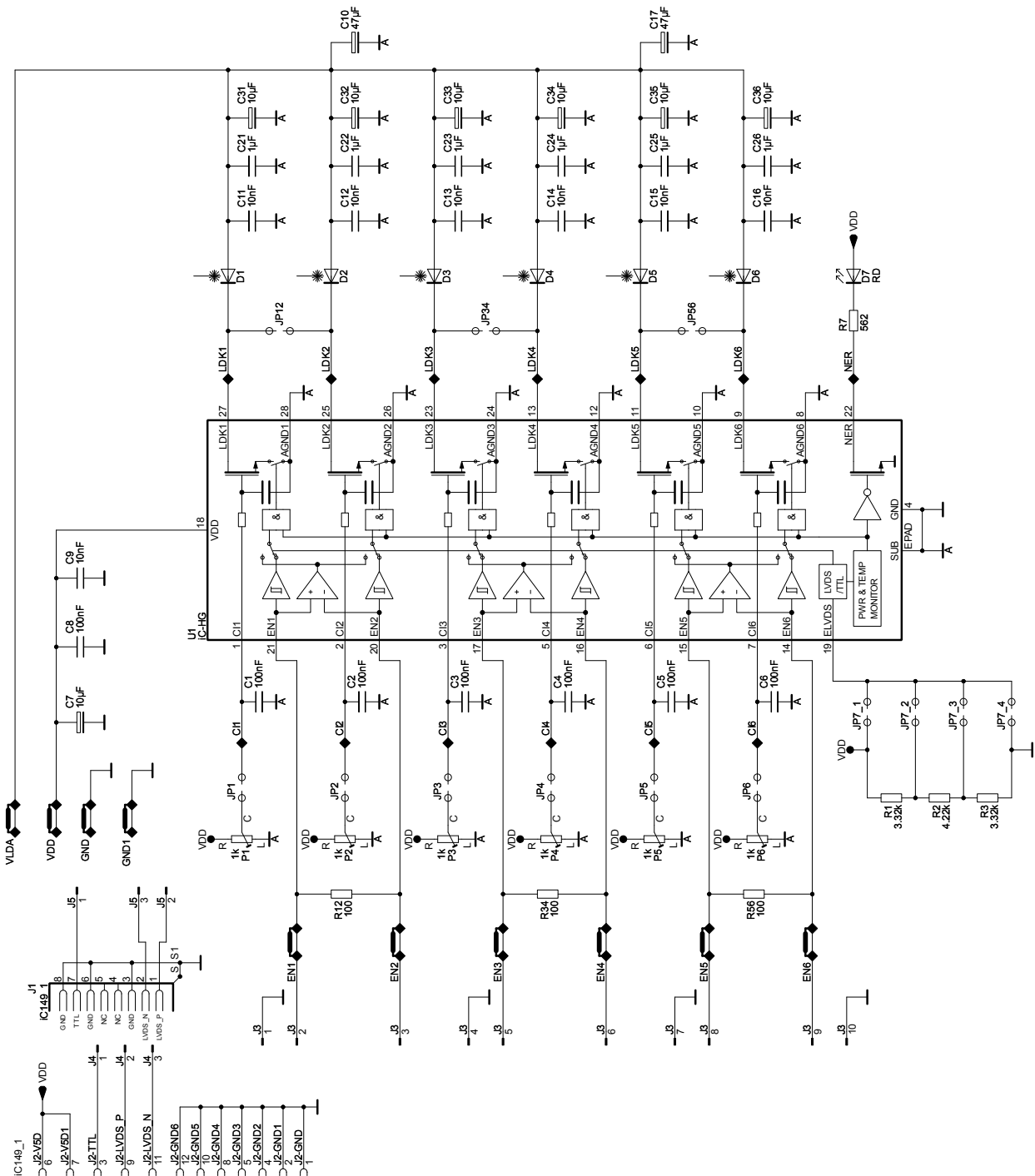

Figure 15: Schematic of the evaluation board

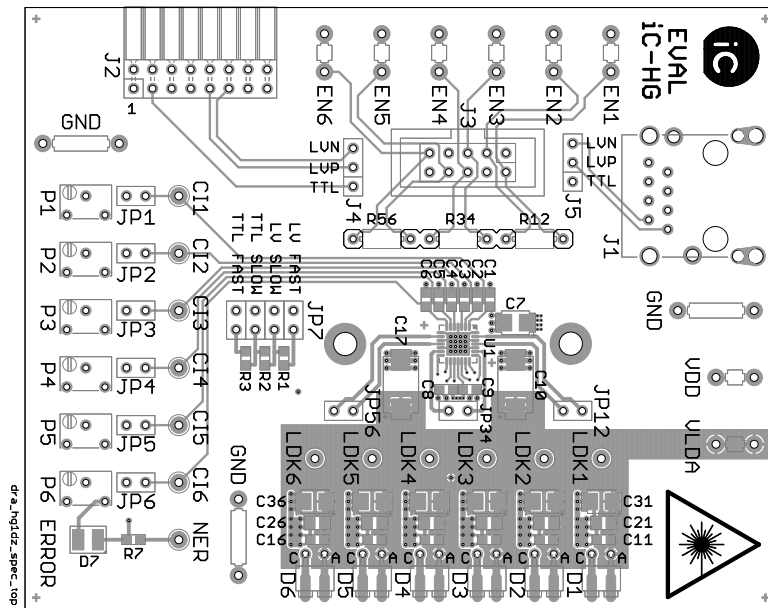

Figure 16: Evaluation board (component side)

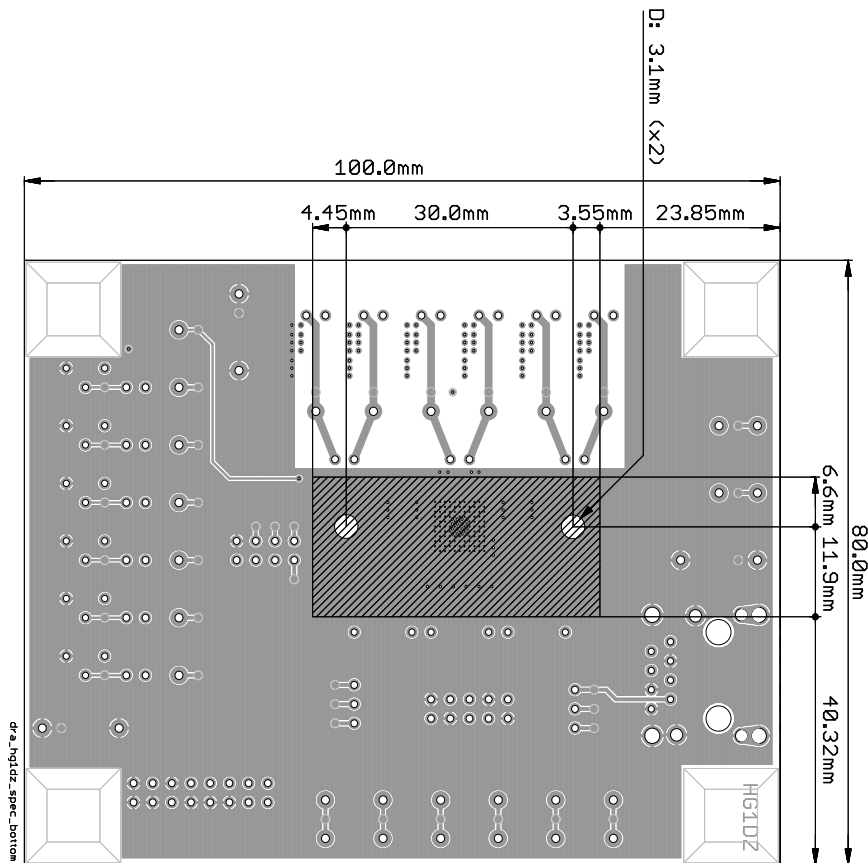

Figure 17: Evaluation board (solder side) with mounting option for heat sink

iC-HG

3 A LASER SWITCH



Rev B1, Page 19/20

iC-Haus expressly reserves the right to change its products and/or specifications. An info letter gives details as to any amendments and additions made to the relevant current specifications on our internet website www.ichaus.de/infoletter; this letter is generated automatically and shall be sent to registered users by email.

Copying – even as an excerpt – is only permitted with iC-Haus' approval in writing and precise reference to source.

iC-Haus does not warrant the accuracy, completeness or timeliness of the specification and does not assume liability for any errors or omissions in these materials.

The data specified is intended solely for the purpose of product description. No representations or warranties, either express or implied, of merchantability, fitness for a particular purpose or of any other nature are made hereunder with respect to information/specification or the products to which information refers and no guarantee with respect to compliance to the intended use is given. In particular, this also applies to the stated possible applications or areas of applications of the product.

iC-Haus conveys no patent, copyright, mask work right or other trade mark right to this product. iC-Haus assumes no liability for any patent and/or other trade mark rights of a third party resulting from processing or handling of the product and/or any other use of the product.

iC-HG

3 A LASER SWITCH



Rev B1, Page 20/20

ORDERING INFORMATION

Type	Package	Options	Order Designation
iC-HG	QFN28 5 mm x 5 mm General Purpose Evaluation Board		iC-HG QFN28 iC-HG EVAL HG1D
	Host adapter for high-speed modules		iC-HG EVAL HG2D
	Host adapter for high-speed modules	with heat-sink assembly kit	iC-HG EVAL HG2D-HSK
	High-speed module for C-mount laser diodes		iC-HG iCSY HG2M
	High-speed module for TO type laser diodes		iC-HG iCSY HG8M

For technical support, information about prices and terms of delivery please contact:

iC-Haus GmbH
Am Kuemmerling 18
D-55294 Bodenheim
GERMANY

Tel.: +49 (61 35) 92 92-0
Fax: +49 (61 35) 92 92-192
Web: <http://www.ichaus.com>
E-Mail: sales@ichaus.com

Appointed local distributors: http://www.ichaus.com/sales_partners