

**Harvatek Surface Mount LED Data Sheet
HT-150 Series**

Official Product	Product: HT-150 Series			Data Sheet No.
Tentative Product	*****			HT-150 Series
Specifications are subject to change without notice. Data and drawings herein are copyrighted.		June 18, 2013	Version of 1.0	Page 1/24

DISCLAIMER..... 3

PRODUCT SPECIFICATIONS 4

ATTENTION: ELECTROSTATIC DISCHARGE (ESD) PROTECTION 5

LABEL SPECIFICATIONS 6

PRODUCT CHARACTERISTICS 11

ABSOLUTE MAXIMUM RATINGS 11

ELECTRO-OPTICAL CHARACTERISTICS..... 12

PACKAGE OUTLINE DIMENSION..... 13

RECOMMENDED SOLDERING PATTERN FOR REFLOW SOLDERING..... 13

CHARACTERISTIC CURVES FOR UYG, UY, UD AND USD 14

CHARACTERISTIC CURVES FOR NB, NG AND TW 15

CHARACTERISTIC CURVES FOR ALL COLORS (RADIATION PATTERN) 16

PACKAGING 17

TAPE DIMENSION 17

REEL DIMENSION 18

PACKING 19

DRY PACK..... 20

REFLOW SOLDERING 21

PRECAUTIONS 22

REWORKING 22

CLEANING 22

RELIABILITY 23

REVISION HISTORY 23

Official Product	Product: HT-150 Series		Data Sheet No.
Tentative Product	*****		HT-150 Series
Specifications are subject to change without notice. Data and drawings herein are copyrighted.	June 18, 2013	Version of 1.0	Page 2/24

DISCLAIMER

HARVATEK reserves the right to make changes without further notice to any products herein to improve reliability, function or design. HARVATEK does not assume any liability arising out of the application or use of any product or circuit described herein; neither does it convey any license under its patent rights, nor the rights of others.

LIFE SUPPORT POLICY

HARVATEK’s products are not authorized for use as critical components in life support devices or systems without the express written approval of the President of HARVATEK or HARVATEK INTERNATIONAL. As used herein:

1. Life support devices or systems are devices or systems which, (a) are intended for surgical implant into the body, or (b) support or sustain life, and (c) whose failure to perform when properly used in accordance with instructions for use provided in the labeling, can be reasonably expected to result in a significant injury of the user.

2. A critical component in any component of a life support device or system whose failure to perform can be reasonably expected to cause the failure of the life support device or system, or to affect its safety or effectiveness.

Official Product	Product: HT-150 Series			Data Sheet No.
Tentative Product	*****			HT-150 Series
Specifications are subject to change without notice. Data and drawings herein are copyrighted.	June 18, 2013	Version of 1.0	Page 3/24	

Product Specifications

Product	Emission Color	Technology	Test Current I_F (mA)	Luminous Intensity I_V (mcd)	Forward Voltage V_F (V)	Orderable Part Number
HT-150UYG	Ultra Bright Yellow Green	AllnGaP	20	71.5 typ	2.0 typ	HT-150UYG-YYYY
HT-150UY	Ultra Bright Yellow	AllnGaP	20	112.5 typ	1.9 typ	HT-150UY-YYYY
HT-150UD	Ultra Bright Orange	AllnGaP	20	112.5 typ	1.9 typ	HT-150UD-YYYY
HT-150USD	Ultra Bright Red	AllnGaP	20	112.5 typ	1.9 typ	HT-150USD-YYYY
HT-150NB	Blue	InGaN	20	112.5 typ	3.3 typ	HT-150NB-YYYY
HT-150NG	True Green	InGaN	20	285 typ	3.3 typ	HT-150NG-YYYY
HT-150TW	White	InGaN	20	300 typ	3.3 typ	HT-150TW-YYYY

Official Product	Product: HT-150 Series		Data Sheet No.
Tentative Product	*****		HT-150 Series
Specifications are subject to change without notice. Data and drawings herein are copyrighted.		June 18, 2013	Version of 1.0
			Page 4/24

	Specification	Material	Quantity
Resin	Water clear	Epoxy resin	
Carrier tape	Per EIA 481-1A specs	Conductive black tape	3000pcs per reel
Reel	Per EIA 481-1A specs	Conductive black	
Label	HT standard	Paper	
Packing bag	220x240mm	Aluminum laminated bag/ no-zipper	One reel per bag
Carton	HT standard	Paper	

Others:

Each immediate box consists of 5 reels. The 5 reels may not necessarily have the same lot number or the same bin combinations of I_V , λ_D and V_f . Each reel has a label identifying its specification; the immediate box consists of a product label as well.

ATTENTION: Electrostatic Discharge (ESD) protection



The symbol to the left denotes that ESD precaution is needed. ESD protection for GaP and AlGaAs based chips is necessary even though they are relatively safe in the presence of low static-electric discharge. Parts built with AlInGaP, GaN, or/and InGaN based chips are **STATIC SENSITIVE devices**. ESD precaution must be taken during design and assembly.

If manual work or processing is needed, please ensure the device is adequately protected from ESD during the process.

Official Product	Product: HT-150 Series	Data Sheet No.
Tentative Product	*****	HT-150 Series
Specifications are subject to change without notice. Data and drawings herein are copyrighted.	June 18, 2013	Version of 1.0
		Page 5/24

Label Specifications

HARVATEK TECHNOLOGIES		Date: yyyy/mm/dd
CUSTOMER P/N: 		
HARVATEK P/N: 	QTY: PCS 	
LOT NO: 	QC	
IV BIN: COLOR BIN: VF:		

■ Harvatek P/N:

H T - 1 5 0 X X X - Y Y Y Y

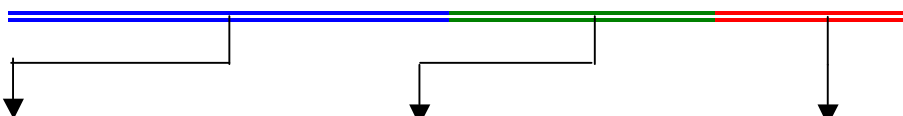

Series Name	Emitting Color	Customer Code
HT-150 HT: Harvatek 150: 1206 series 3.2 (L) x 1.6 (W) x 1.1 (H) mm	XXX UYG: Ultra Bright Yellow Green UY: Ultra Bright Yellow UD: Ultra Bright Orange USD: Ultra Bright Red NB: Blue NG: True Green TW: White	YYYY Customer Product Code (TBD)

Official Product	Product: HT-150 Series		Data Sheet No.
Tentative Product	*****		HT-150 Series
Specifications are subject to change without notice. Data and drawings herein are copyrighted.	June 18, 2013	Version of 1.0	Page 6/24

Lot No.:

1	2	3	4	5	6	7	8	9	10
E	1	A	1	A	2	2	L	1	2
Code 1 2		Code 3	Code 4	Code 5	Code 6	Code 7	Code 8	Code 9	Code 10
		Mfg. Year	Mfg. Month	Mfg. Date	Consecutive number		Special code		
Internal Tracing Code		2010-A 2011-B 2012-C 2013-D . .	1:Jan. 2:Feb. ... A:Oct. B:Nov. C:Dec.	1:A 2:B 3:C ... 26:Z 27:7 28:8 29:9 30:3 31:4	01~ZZ		000~ZZZ		

■ **Luminous Intensity (Iv) Bin:**

Bin	Luminous Intensity Range (mcd)		Bin	Luminous Intensity Range (mcd)	
	Minimum	Maximum		Minimum	Maximum
N1	28.5	36.0	N2	36.0	45.0
P1	45.0	57.0	P2	57.0	71.5
Q1	71.5	90.0	Q2	90.0	112.5
R1	112.5	142.0	R2	142.0	180.0
S1	180.0	227.0	S2	227.0	285.0
T1	285.0	360.0	T2	360.0	450.0
U1	450.0	570.0	U2	570.0	715.0

@20mA / Ta=25° C, Tolerance: ± 10%

Official Product	Product: HT-150 Series	Data Sheet No.
Tentative Product	*****	HT-150 Series
Specifications are subject to change without notice. Data and drawings herein are copyrighted.	June 18, 2013	Version of 1.0
		Page 7/24

■ Wavelength (λ_D) Bin:

Bin	Wavelength Range (nm)							
	Red (USD)		Orange (UD)		Yellow (UY)		Yellow Green (UYG)	
	Min	Max	Min	Max	Min	Max	Min	Max
-	615.0	630.0						
A			597.0	600.0	582.0	584.5	561.5	564.5
B			600.0	603.0	584.6	587.0	564.5	567.5
C			603.0	606.0	587.0	589.5	567.5	570.5
D			606.0	609.0	589.5	592.0	570.5	573.5
E			609.0	612.0			573.5	576.5
F			612.0	615.0				
H					592.0	594.5		
J					594.5	597.0		

@20mA / Ta=25^o C, Tolerance: \pm 0.5nm

Bin	Wavelength Range (nm)			
	True Green (NG)		Blue (NB)	
	Min	Max	Min	Max
-				
A	515.0	520.0	460.0	464.0
B	520.0	525.0	464.0	468.0
C	525.0	530.0	468.0	472.0
D	530.0	535.0	472.0	476.0
E	535.0	540.0	476.0	480.0
F			480.0	485.0
H				
J				

@20mA / Ta=25^o C, Tolerance: \pm 0.5nm

Official Product	Product: HT-150 Series	Data Sheet No.
Tentative Product	*****	HT-150 Series
Specifications are subject to change without notice. Data and drawings herein are copyrighted.	June 18, 2013	Version of 1.0
		Page 8/24

■ Forward Voltage (V_F) Bin:

Color	Bin Code	Spec. Range
Blue (NB) Green (NG) White (TW)	G8	2.7-2.9 V
	H7	2.9-3.1 V
	H8	3.1-3.3 V
	J7	3.3-3.5 V
	J8	3.5-3.7 V
	K7	3.7-3.9 V
Ultra Bright (UYG, UY, UD, USD)	-	2.4 V max

@20mA / Ta=25°C, Tolerance: ± 0.05 V

Official Product	Product: HT-150 Series		Data Sheet No.
Tentative Product	*****		HT-150 Series
Specifications are subject to change without notice. Data and drawings herein are copyrighted.	June 18, 2013	Version of 1.0	Page 9/24

Chromaticity Bin (for TW only):

		Rank C1			
x		0.2500	0.2700	0.2700	0.2500
y		0.2500	0.2775	0.2325	0.2050

		Rank C2			
x		0.2700	0.2900	0.2900	0.2700
y		0.2775	0.3050	0.2600	0.2325

		Rank D1			
x		0.2900	0.3100	0.3100	0.2900
y		0.3050	0.3325	0.2875	0.2600

		Rank D2			
x		0.3100	0.3300	0.3300	0.3100
y		0.3325	0.3600	0.3150	0.2875

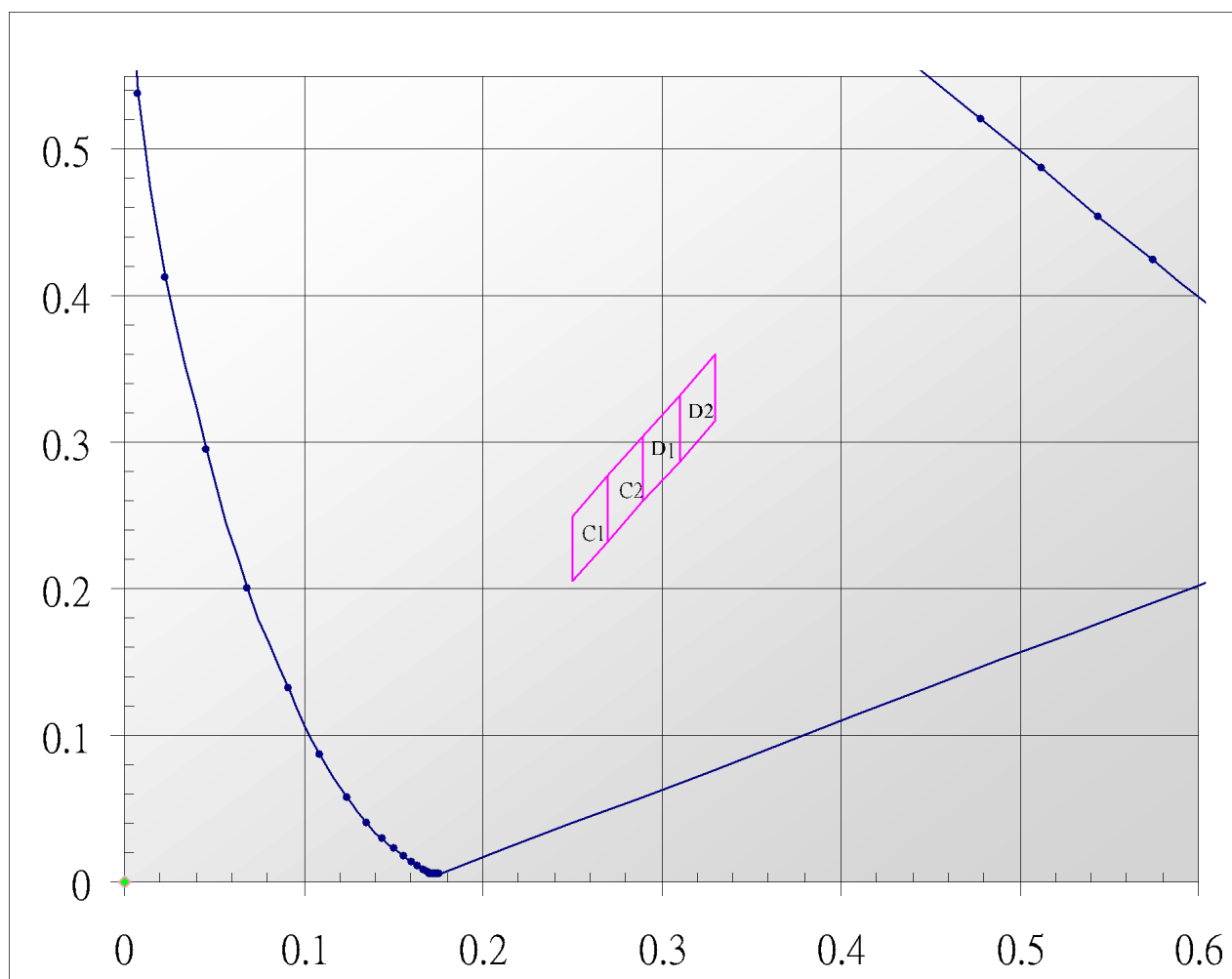

@20mA / Ta=25°C, Tolerance: ± 0.01

Official Product	Product: HT-150 Series	Data Sheet No.
Tentative Product	*****	HT-150 Series
Specifications are subject to change without notice. Data and drawings herein are copyrighted.	June 18, 2013	Version of 1.0
		Page 10/24

Product Characteristics

Absolute Maximum Ratings

Product	Emission Color	P _d (mW)	I _F (mA)	I _{FP} * (mA)	V _R (V)	T _{OP} (°C)	T _{ST} (°C)
HT-150UYG	Ultra Bright Yellow Green	72	30	100	5	-30°C~+80°C	-40°C~+85°C
HT-150UY	Ultra Bright Yellow						
HT-150UD	Ultra Bright Orange						
HT-150USD	Ultra Bright Red						
HT-150NB	Blue	78	20	80			
HT-150NG	True Green						
HT-150TW	White						

* Condition for I_{FP} is pulse of 1/10 duty and 0.1msec width

**Remarks: This product should be operated in forward bias. If a reverse voltage is continuously applied to the product, such operation can cause migration resulting in LED damage.

Official Product	Product: HT-150 Series		Data Sheet No.
Tentative Product	*****		HT-150 Series
Specifications are subject to change without notice. Data and drawings herein are copyrighted.		June 18, 2013	Version of 1.0
			Page 11/24

Electro-Optical Characteristics

(T_a 25 °C)

Product	Emission Color	I _F (mA)	V _F (V)		λ(nm)			I _V (mcd)	
			typ	max	λ _D	λ _P	Δλ	min	typ
HT-150UYG	Ultra Bright Yellow Green	20	2.0	2.4	573	574	20	35	60
HT-150UY	Ultra Bright Yellow	20	1.9	2.4	591	593	15	40	90
HT-150UD	Ultra Bright Orange	20	1.9	2.4	605	609	17	50	120
HT-150USD	Ultra Bright Red	20	1.9	2.4	622	636	17	50	120
HT-150NB	Blue	20	3.3	3.9	470	468	40	25	70
HT-150NG	True Green	20	3.3	3.9	527	520	40	65	160
HT-150TW	White	20	3.3	3.9	X=0.29 Y=0.31	-	-	140	220

* Per NIST standards

Official Product	Product: HT-150 Series		Data Sheet No.
Tentative Product	*****		HT-150 Series
Specifications are subject to change without notice. Data and drawings herein are copyrighted.		June 18, 2013	Version of 1.0
			Page 12/24

**Package Outline Dimension
Recommended Soldering Pattern for Reflow Soldering**

Unit: mm Tolerance: +/-0.1

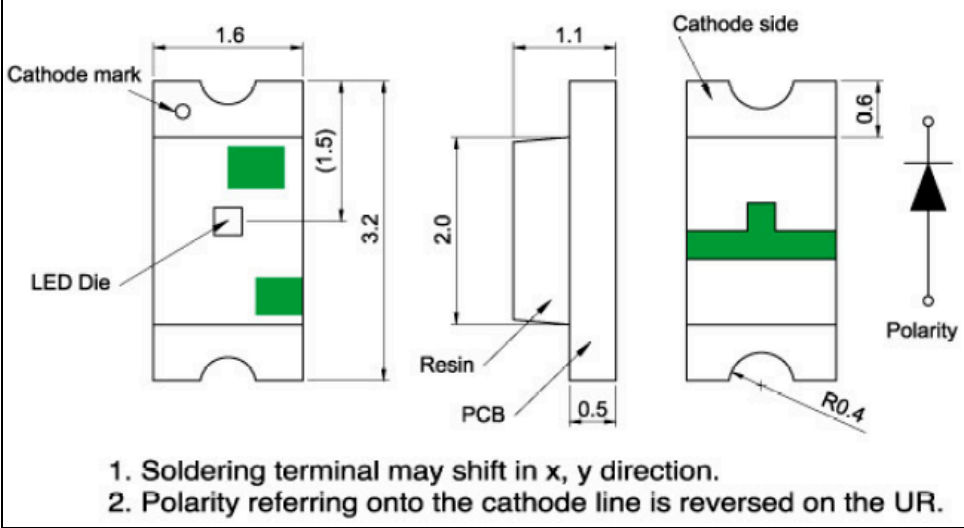
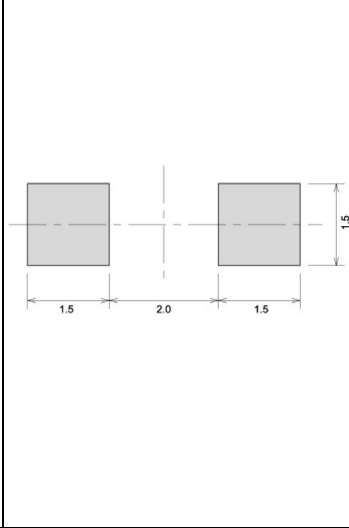
Outline Dimension	Solder Pattern
 <p>1. Soldering terminal may shift in x, y direction. 2. Polarity referring onto the cathode line is reversed on the UR.</p>	
<p>Soldering terminals may shift in the x, y direction.</p>	<p>Unit: mm</p>

Official Product	Product: HT-150 Series	Data Sheet No.
Tentative Product	*****	HT-150 Series
Specifications are subject to change without notice. Data and drawings herein are copyrighted.	June 18, 2013	Version of 1.0 Page 13/24

Characteristic Curves for UYG, UY, UD and USD

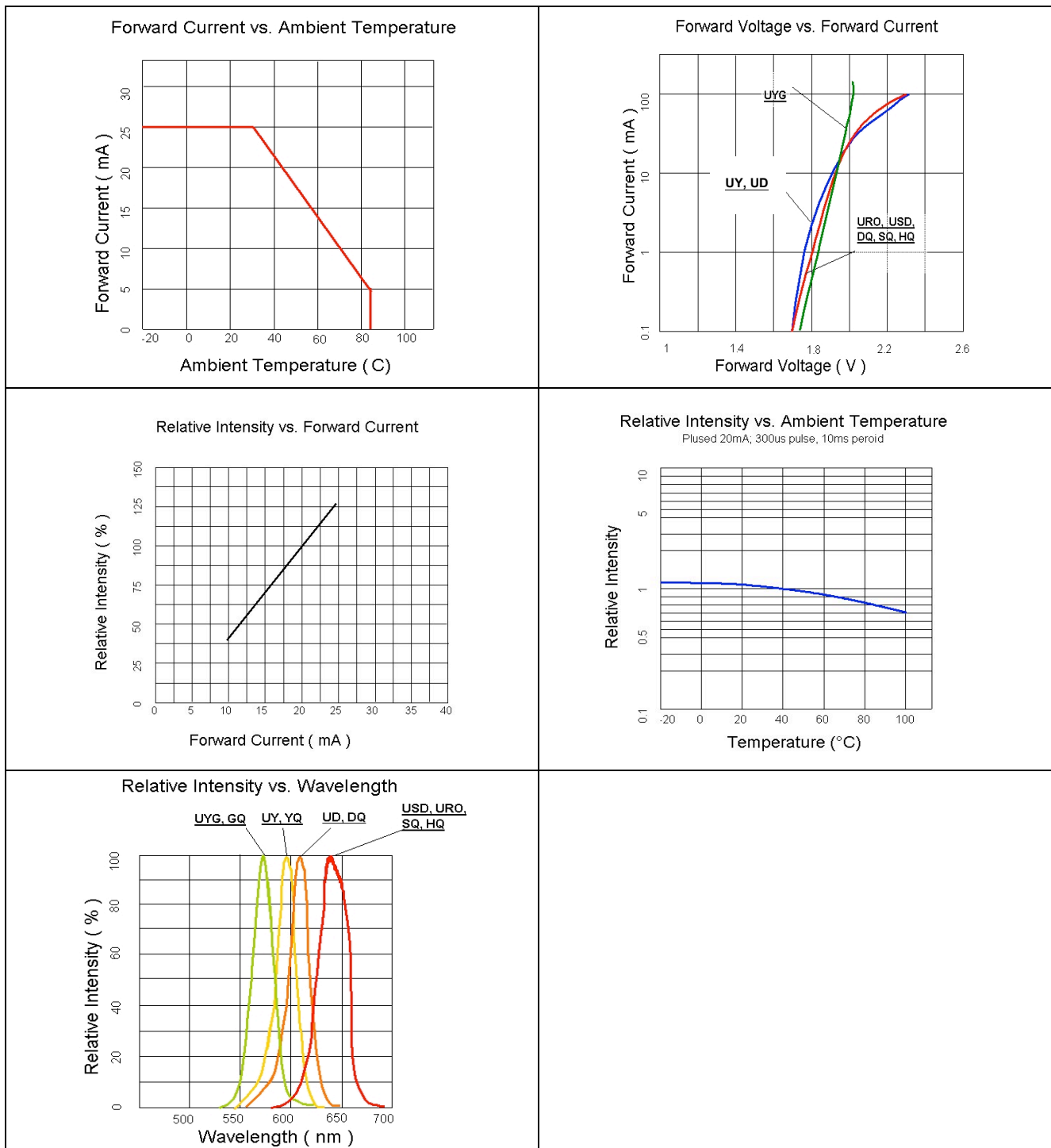

Official Product	Product: HT-150 Series	Data Sheet No.
Tentative Product	*****	HT-150 Series
Specifications are subject to change without notice. Data and drawings herein are copyrighted.	June 18, 2013	Version of 1.0
		Page 14/24

Characteristic Curves for NB, NG and TW

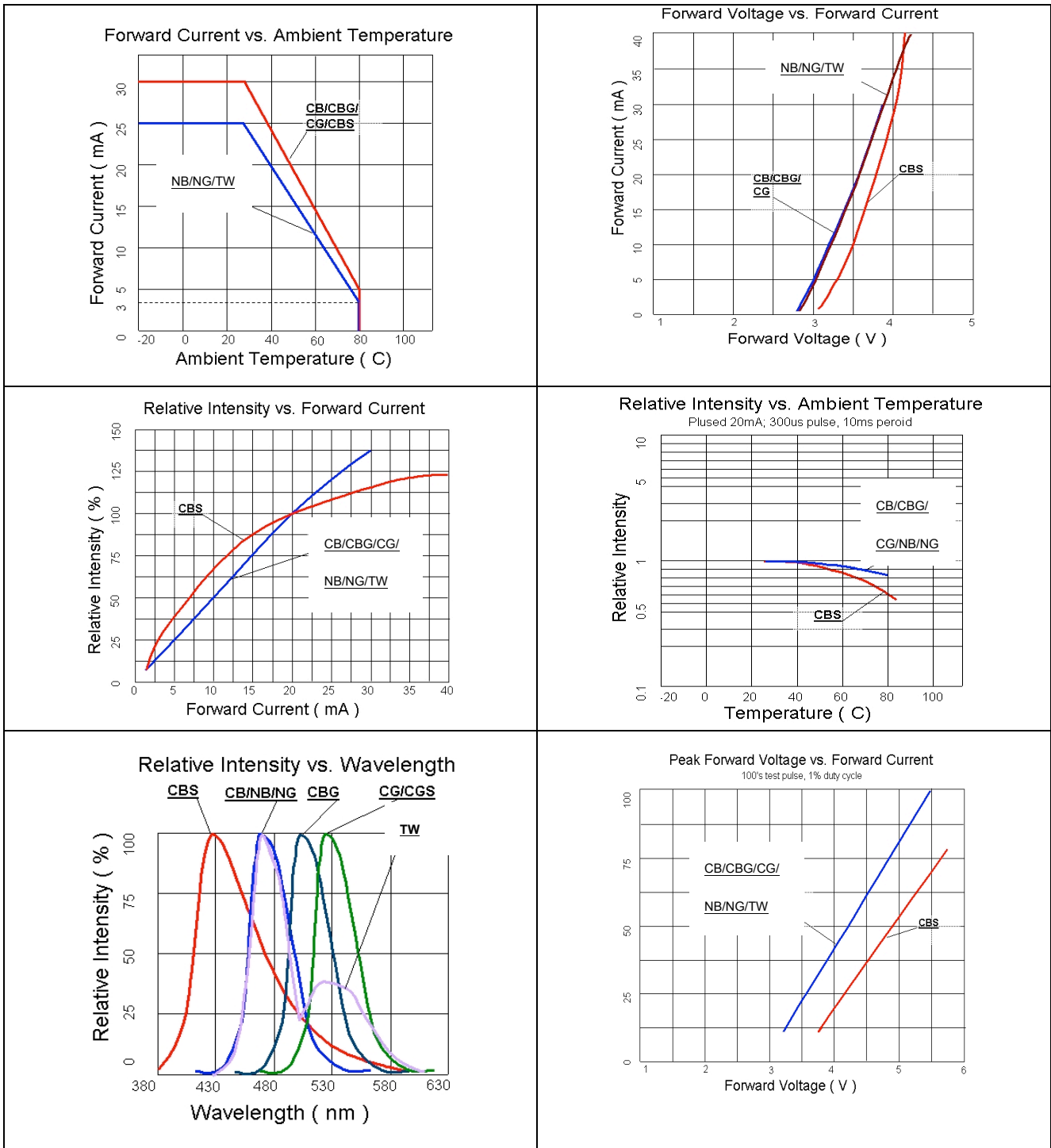

Official Product	Product: HT-150 Series	Data Sheet No.
Tentative Product	*****	HT-150 Series
Specifications are subject to change without notice. Data and drawings herein are copyrighted.	June 18, 2013	Version of 1.0
		Page 15/24

Characteristic Curves for All Colors (Radiation Pattern)

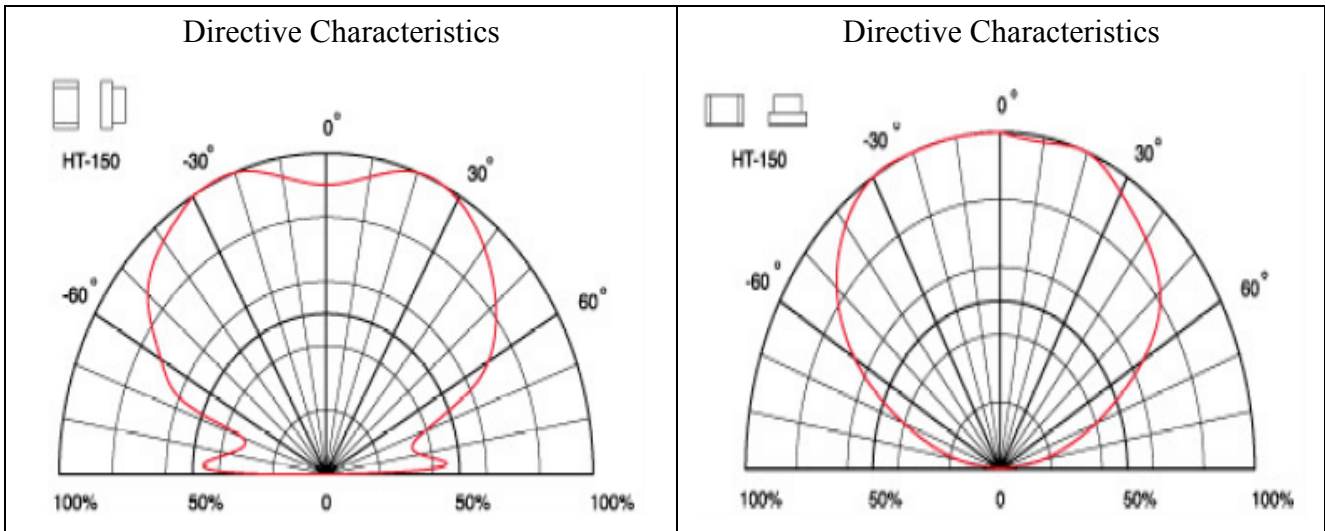

Official Product	Product: HT-150 Series	Data Sheet No.
Tentative Product	*****	HT-150 Series
Specifications are subject to change without notice. Data and drawings herein are copyrighted.	June 18, 2013	Version of 1.0
		Page 16/24

Packaging

Tape Dimension

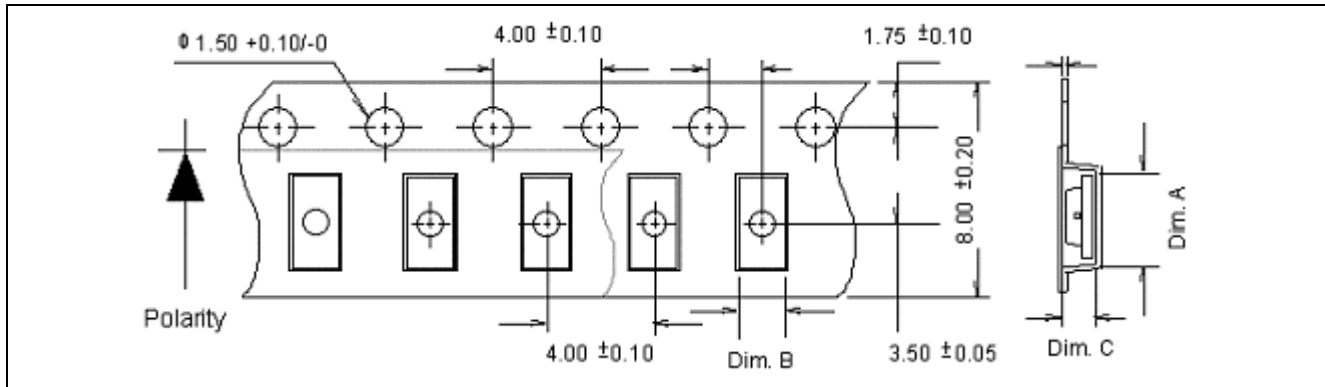

Part No.	Dim. A	Dim. B	Dim. C	Q'ty/Reel
HT-150	3.50± 0.10	1.88± 0.10	1.27± 0.10	3K

Unit: mm

Official Product	Product: HT-150 Series		Data Sheet No.
Tentative Product	*****		HT-150 Series
Specifications are subject to change without notice. Data and drawings herein are copyrighted.	June 18, 2013	Version of 1.0	Page 17/24

Reel Dimension

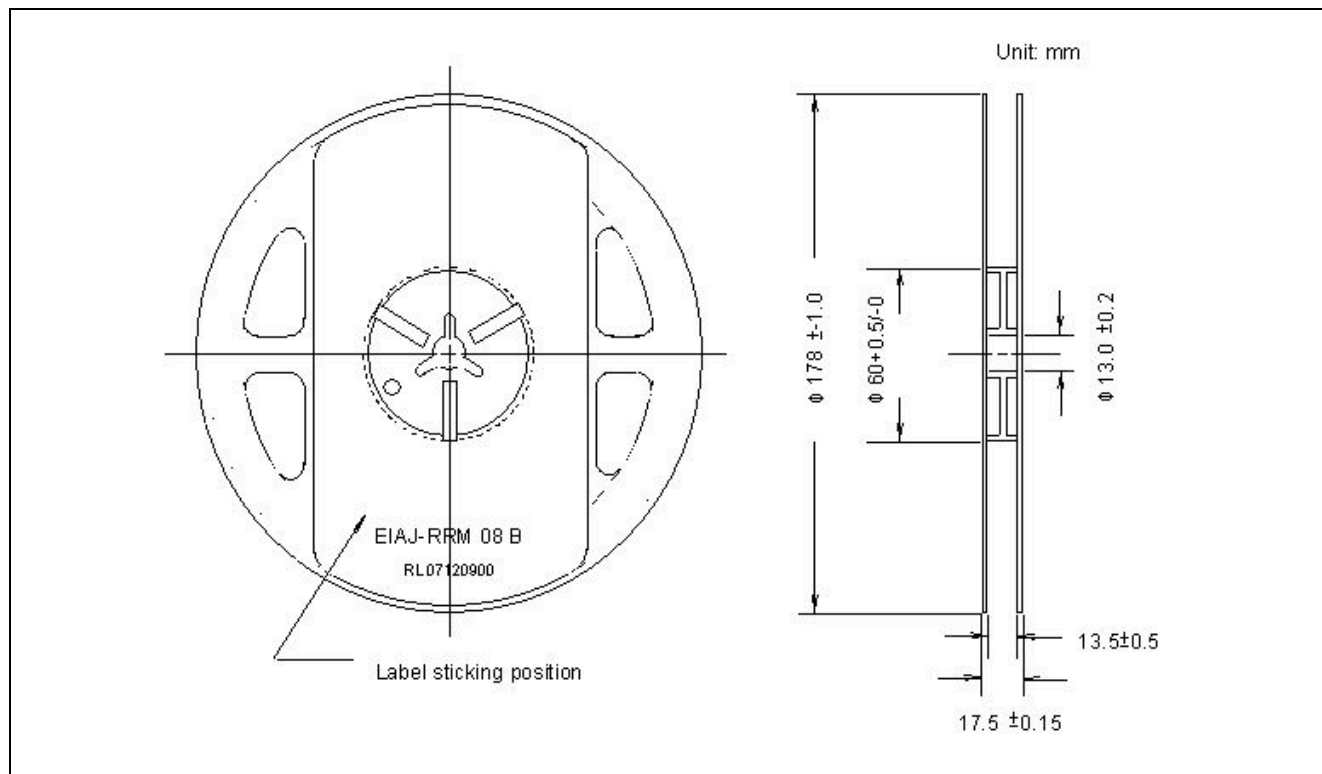

Official Product	Product: HT-150 Series		Data Sheet No.
Tentative Product	*****		HT-150 Series
Specifications are subject to change without notice. Data and drawings herein are copyrighted.	June 18, 2013	Version of 1.0	Page 18/24

Packing

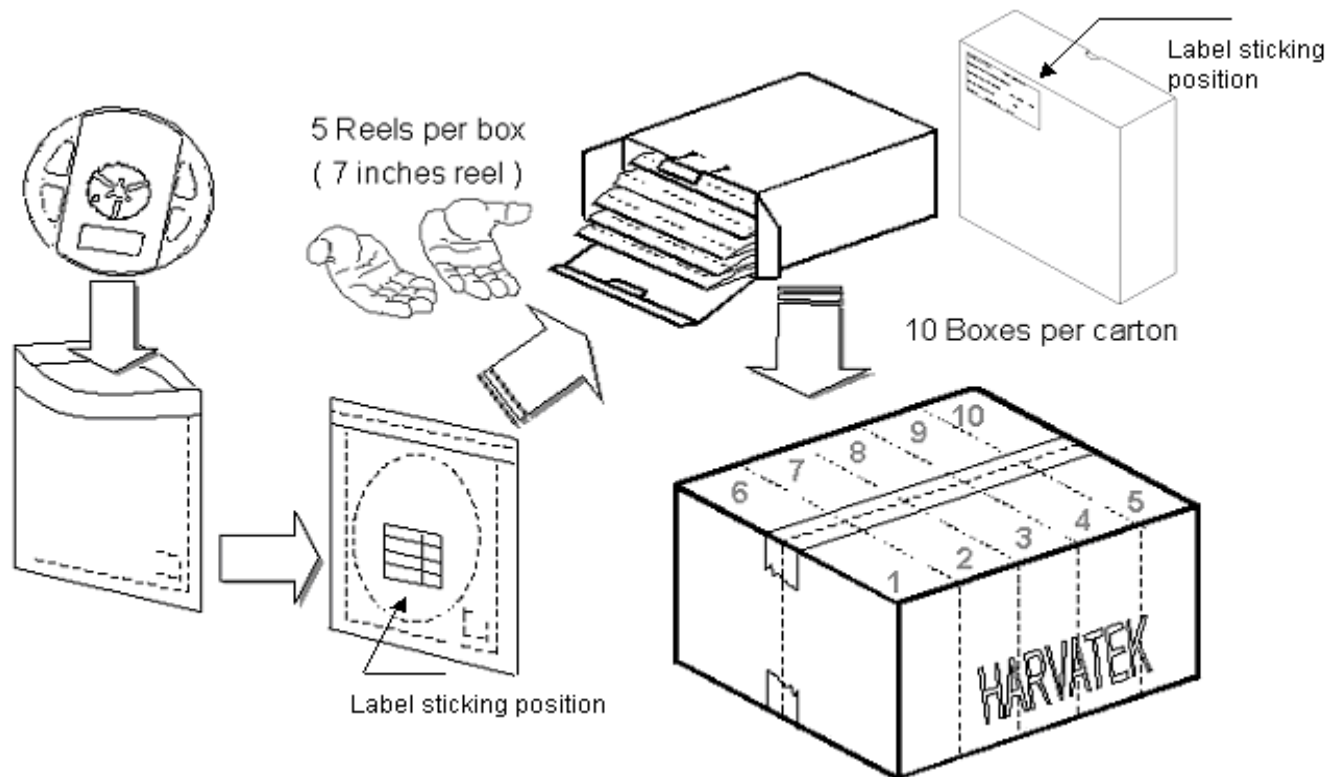

5 boxes per carton is available depending on shipment quantity.

	Specification	Material	Quantity
Carrier tape	Per EIA 481-1A specs	Conductive black tape	3000pcs per reel
Reel	Per EIA 481-1A specs	Conductive black	
Label	HT standard	Paper	
Packing bag	220x240mm	Aluminum laminated bag/ no-zipper	One reel per bag
Carton	HT standard	Paper	Non-specified

Others:

Each immediate box consists of 5 reels. The 5 reels may not necessarily have the same lot number or the same bin combinations of Iv, λ_D and Vf. Each reel has a label identifying its specification; the immediate box consists of a product label as well.

Official Product	Product: HT-150 Series	Data Sheet No.
Tentative Product	*****	HT-150 Series
Specifications are subject to change without notice. Data and drawings herein are copyrighted.	June 18, 2013	Version of 1.0
		Page 19/24

Dry Pack

All SMD optical devices are **MOISTURE SENSITIVE**. Avoid exposure to moisture at all times during transportation or storage. Every reel is packaged in a moisture protected anti-static bag. Each bag is properly sealed prior to shipment.

Upon request, a humidity indicator will be included in the moisture protected anti-static bag prior to shipment.

The packaging sequence is as follows:

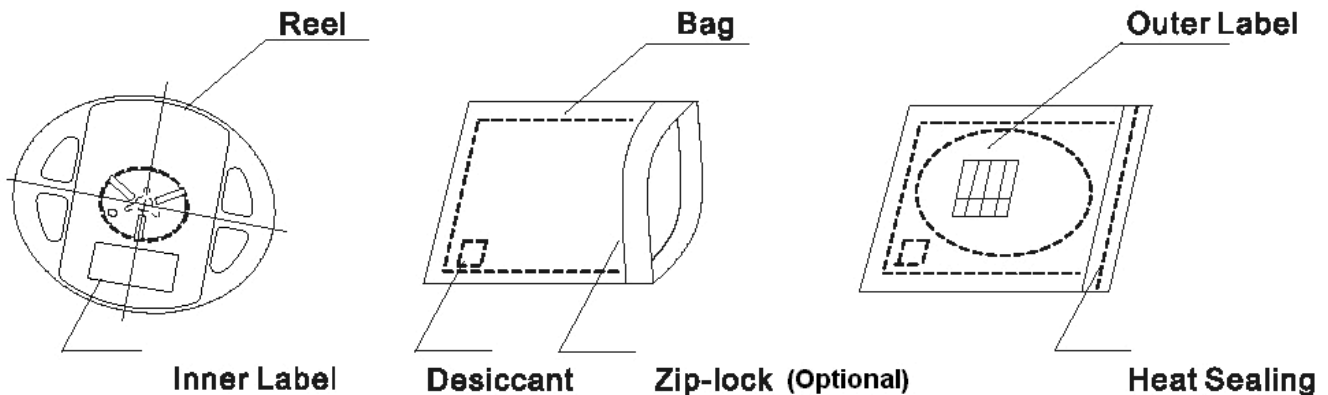

Official Product	Product: HT-150 Series		Data Sheet No.
Tentative Product	*****		HT-150 Series
Specifications are subject to change without notice. Data and drawings herein are copyrighted.	June 18, 2013	Version of 1.0	Page 20/24

Reflow Soldering

- Recommended tin glue specifications: melting temperature in the range of 178~192 °C
- The recommended reflow soldering profile is as follows (temperatures indicated are as measured on the surface of the LED resin):

Lead Solder Profile

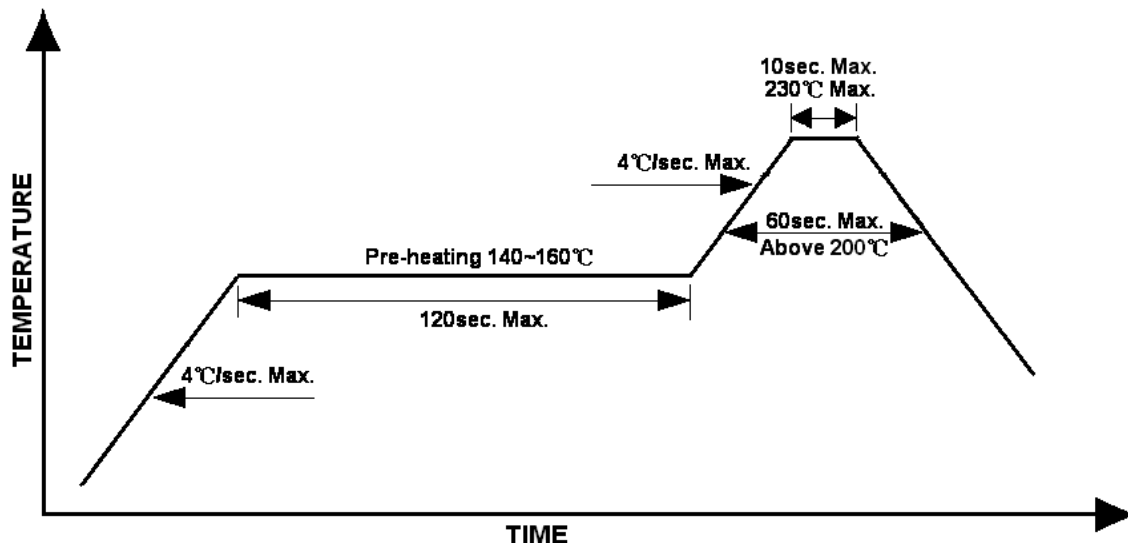

Lead-free Solder Profile

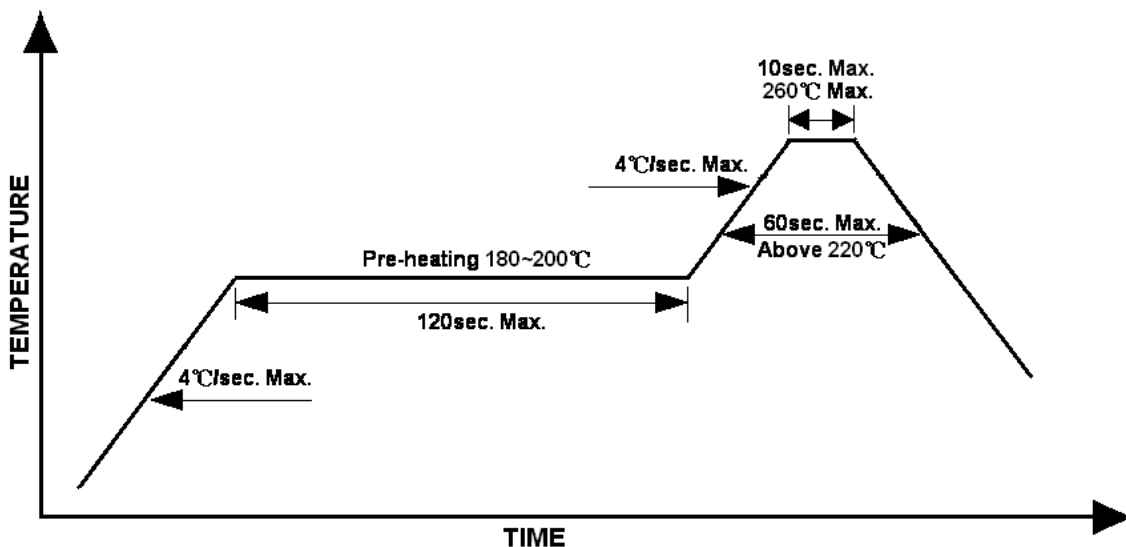

Official Product	Product: HT-150 Series	Data Sheet No.	
Tentative Product	*****	HT-150 Series	
Specifications are subject to change without notice. Data and drawings herein are copyrighted.	June 18, 2013	Version of 1.0	Page 21/24

Precautions

1. Avoid exposure to moisture at all times during transportation or storage.
2. Anti-Static precaution must be taken when handling GaN, InGaN, and AlInGaP products.
3. It is suggested to connect the unit with a current limiting resistor of the proper size. Avoid applying a reverse voltage.
4. Avoid operation beyond the limits as specified by the absolute maximum ratings.
5. Avoid direct contact with the surface through which the LED emits light.
6. If possible, assemble the unit in a clean room or dust-free environment.

Reworking

- Rework should be completed within 5 seconds under 260 °C.
- The iron tip must not come in contact with the copper foil.
- Twin-head type is preferred.

Cleaning

Following are cleaning procedures after soldering:

- An alcohol-based solvent such as isopropyl alcohol (IPA) is recommended.
- Temperature x Time should be 50°C x 30sec. or <30°C x 3min
- Ultra sonic cleaning: < 15W/ bath; bath volume ≤ 1liter
- Curing: 100 °C max, <3min

Cautions of Pick and Place

- Avoid stress on the resin at elevated temperature.
- Avoid rubbing or scraping the resin by any object.
- Electro-static may cause damage to the component. Please ensure that the equipment is properly grounded. Use of an ionizer fan is recommended.

Official Product	Product: HT-150 Series		Data Sheet No.
Tentative Product	*****		HT-150 Series
Specifications are subject to change without notice. Data and drawings herein are copyrighted.	June 18, 2013	Version of 1.0	Page 22/24

Reliability

Item	Frequency/ lots/ samples/ failures	Standards Reference	Conditions
Precondition	For all reliability monitoring tests according to JEDEC Level 2	J-STD-020	1.) Baking at 85°C for 24hrs 2.) Moisture storage at 85°C/ 60% R.H. for 168hrs
Solderability	1Q/ 1/ 22/ 0	JESD22-B102-B And CNS-5068	Accelerated aging 155°C/ 24hrs Tinning speed: 2.5+0.5cm/s Tinning: A: 215°C/ 3+1s or B: 260°C/ 10+1s
Resistance to soldering heat		CNS-5067	Dipping soldering terminal only Soldering bath temperature A: 260+/-5°C; 10+/-1s B: 350+/-10°C; 3+/-0.5s
Operating life test	1Q/ 1/ 40/ 0	CNS-11829	1.) Precondition: 85°C baking for 24hrs 85°C/ 60%R.H. for 168hrs 2.) Tamb25°C; IF=20mA; duration 1000hrs
High humidity, high temperature bias	1Q/ 1/ 45/ 0	JESD-A101-B	Tamb: 85°C Humidity: 85% R.H., IF=5mA Duration: 1000hrs
High temperature bias	1Q/ 1/ 20	HT specs.	Tamb: 55°C IF=20mA Duration: 1000hrs
Pulse life test	1Q/ 1/ 40/ 0		Tamb25°C, If=20mA., Ip=100mA, Duty cycle=0.125 (tp=125 μs, T=1sec) Duration 500hrs)
Temperature cycle	1Q/ 1/ 76/ 0	JESD-A104-A IEC 68-2-14, Nb	A cycle: -40 degree C 15min; +85 degree C 15min Thermal steady within 5 min.. 300 cycles 2 chamber/ Air-to-air type
High humidity storage test	1Q/ 1/ 40/ 0	CNS-6117	60+3°C 90+5/-10% R.H. for 500hrs
High temperature storage test	1Q/ 1/ 40/ 0	CNS-554	100+10°C for 500hrs
Low temperature storage test	1Q/ 1/ 40/ 0	CNS-6118	-40+5°C for 500hrs

Revision History

Changes since last revision		Page	Version No.	Revision Date
Official Product	Product: HT-150 Series			Data Sheet No.
Tentative Product	*****			HT-150 Series
Specifications are subject to change without notice. Data and drawings herein are copyrighted.		June 18, 2013	Version of 1.0	Page 23/24

New format		1.0	06-02-2005
Initial Release			06-18-2013

Official Product	Product: HT-150 Series		Data Sheet No.
Tentative Product	*****		HT-150 Series
Specifications are subject to change without notice. Data and drawings herein are copyrighted.	June 18, 2013	Version of 1.0	Page 24/24