

HSMW-A10x-xxxxx

White Surface Mount LED Indicator SMT PLCC-2



Data Sheet



Lead (Pb) Free
RoHS 6 fully
compliant



Description

This family of SMT LEDs is packaged in the industry standard PLCC-2 package. These SMT LEDs have high reliability performance and are designed to work under a wide range of environmental conditions. This high reliability feature makes them ideally suited to be used under harsh interior automotive as well as interior signs application conditions.

To facilitate easy pick & place assembly, the LEDs are packed in EIA-compliant tape and reel. Every reel will be shipped in single intensity and color bin.

These LEDs are compatible with IR solder reflow process.

The wide viewing angle at 120° makes these LEDs ideally suited for panel, push button, or general backlighting in automotive interior, office equipment, industrial equipment, and home appliances. The flat top emitting surface makes it easy for these LEDs to mate with light pipes. With the built-in reflector pushing up the intensity of the light output, these LEDs are also suitable to be used as LED pixels in interior electronic signs.

The super high brightness white PLCC-2 SMT LED is ideal for all kinds of backlighting applications in interior automotive, office automation, electrical appliance and industrial instrument markets to offer a clear and attractive product differentiation. The wide viewing angle at 120° also enables this white PLCC-2 SMT LED to be used in localised area ambience lighting in applications such as vanity mirror light, cabin light, and car door puddle light. The white color backlighting offered by this series of white PLCC-2 SMT LED is suitable to backlight color LCD screen in applications such as GPS (global positioning system) screens in cars.

Features

- Industry standard PLCC-2 package (plastic leaded chip carrier)
- High reliability LED package with silicone encapsulation
- Tight white color binning
- Wide viewing angle at 120°
- Available in 8 mm carrier tape on 7-inch reel (2000 pieces)
- Compatible with Reflow and TTW soldering process

Applications

- Interior automotive
 - Instrument panel backlighting
 - Central console backlighting
 - Cabin backlighting
- Office automation, home appliances, industrial equipment
 - Front panel backlighting
 - Push button backlighting
 - Display backlighting

CAUTION: HSMW-A10x LEDs are Class 2 ESD sensitive. Please observe appropriate precautions during handling and processing. Refer to Avago Technologies Application Note AN-1142 for additional details.

Package Dimensions

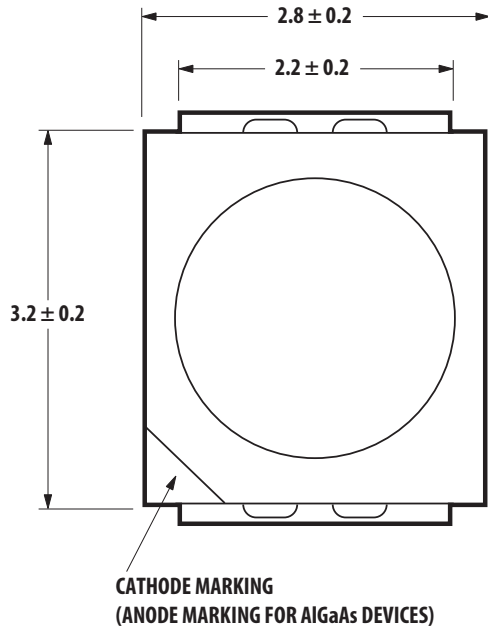

TOP MOUNT

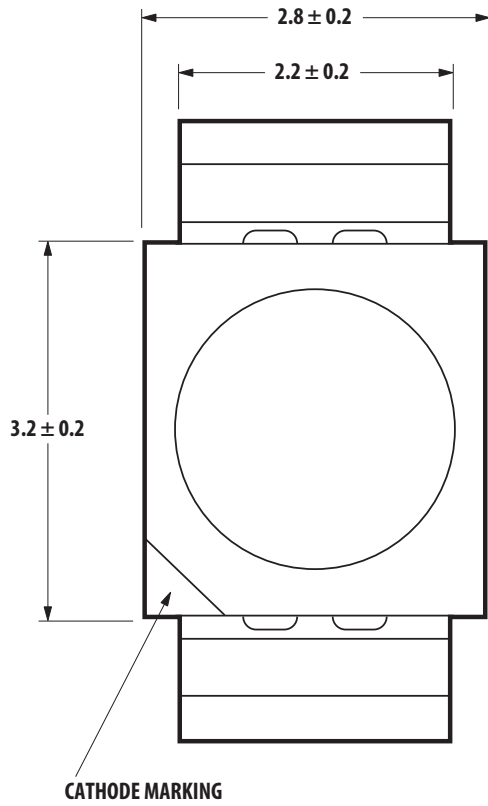
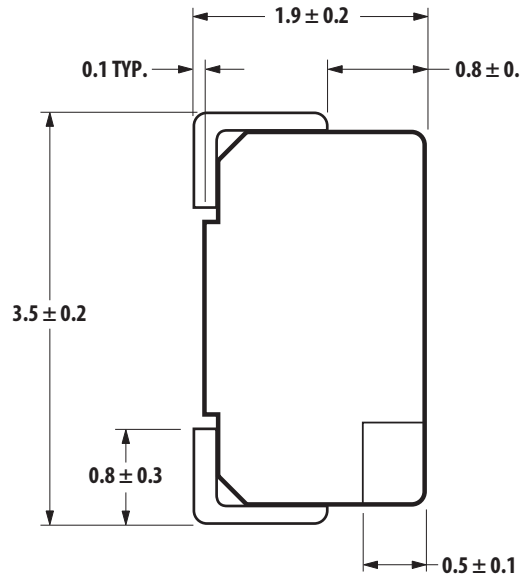

REVERSE MOUNT

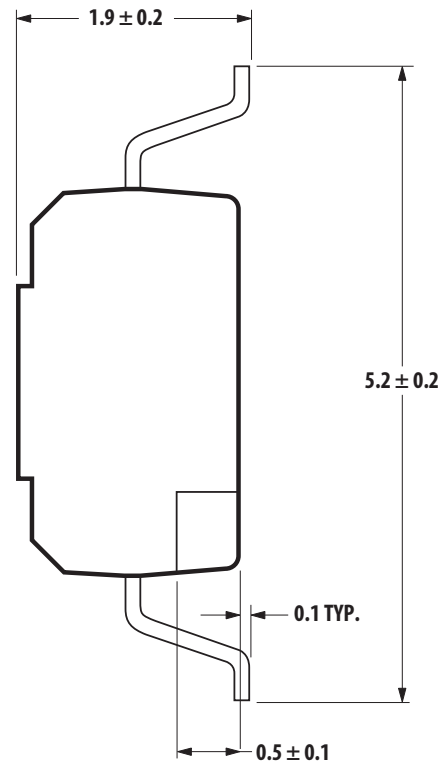

NOTE: ALL DIMENSIONS IN MILLIMETERS.

Device Selection Guide

Color	Part Number	Min. I_V (mcd)	Typ. I_V (mcd)	Max. I_V (mcd)	Test Current (mA)	Dice Technology
White	HSMW-A100-U40H1	450.0	-	1125.0	20	InGaN
	HSMW-A100-U40J1	450.0	-	1125.0	20	InGaN

Notes:

1. The luminous intensity I_V is measured at the mechanical axis of the lamp package. The actual peak of the spatial radiation pattern may not be aligned with this axis.
2. I_V tolerance = $\pm 12\%$.

Part Numbering System

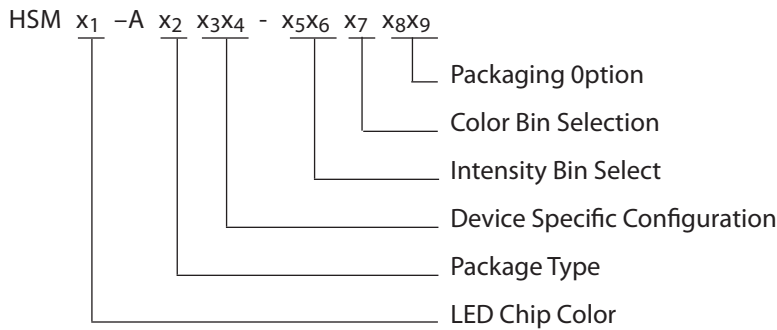

Absolute Maximum Ratings ($T_A = 25^\circ\text{C}$)

Parameters	HSMW
DC Forward Current ^[1]	30 mA
Peak Forward Current ^[2]	90 mA
Power Dissipation	114 mW
Reverse Voltage	5 V
Junction Temperature	110°C
Operating Temperature	-40°C to +100°C
Storage Temperature	-40°C to +100°C

Notes:

1. Derate linearly as shown in Figure 4.
2. Duty factor = 10%, frequency = 1 kHz.

Optical Characteristics (T_A = 25°C)

Color	Part Number	Dice Technology	Typ. Chromaticity Coordinates ^[1]		Viewing Angle 2θ _{1/2} ^[2] (Degrees)	Luminous Efficiency, η _e (lm/W)	Total Flux/ Luminous Intensity Φ _V (lm) / I _V (mcd)
			x	y	Typ.	Typ.	Typ.
White	HSMW-A100	InGaN	0.31	0.31	120	18	2.4
White	HSMW-A101	InGaN	0.31	0.31	120	9	2.4

Notes:

1. The chromaticity coordinates are derived from the CIE 1931 Chromaticity Diagram and represent the perceived color of the device.
2. θ_{1/2} is the off-axis angle where the luminous intensity is 1/2 the peak intensity.

Electrical Characteristics (T_A = 25°C)

Part Number	Forward Voltage, V _F (Volts) @ I _F = 20 mA		Reverse Voltage, V _R @ 10 μA	Thermal Resistance
	Typ.	Max.	Min.	R _{θJP} (°C/W)
HSMW	3.4	4.05	5	280

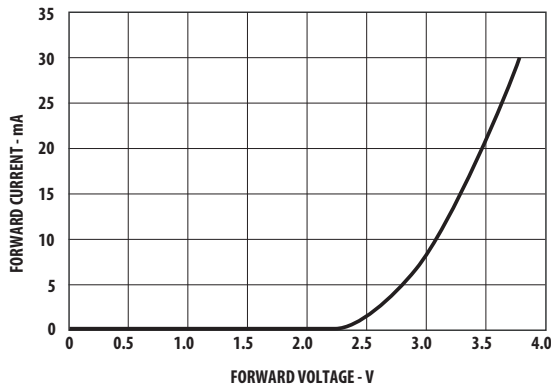

Figure 1. Forward Current vs. forward voltage

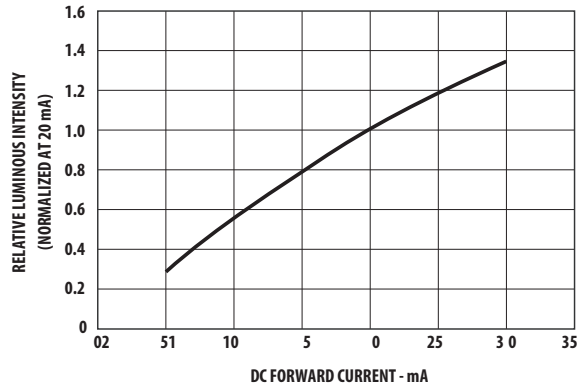

Figure 2. Relative intensity vs. forward current.

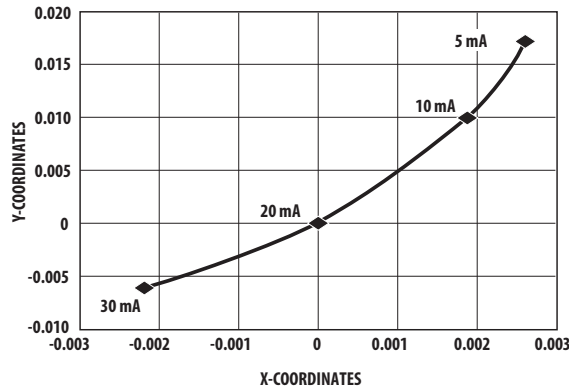

Figure 3. Chromaticity shift vs. current.
Note: (x,y) values @ 20 mA reference to (0,0)

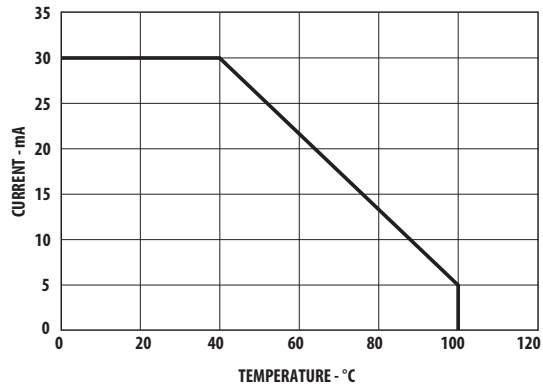

Figure 4. Maximum forward current vs. ambient temperature.
Derated based on T_JMAX = 110°C, R_{θJA} = 500°C/W.

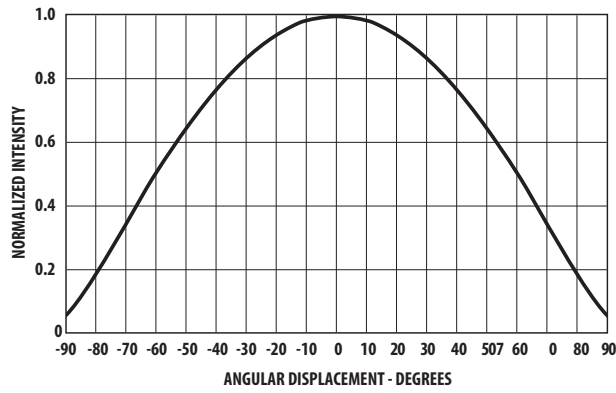
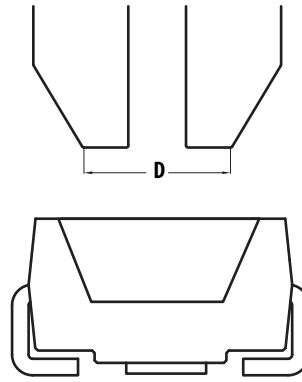

Figure 5. Radiation pattern



Note: Diameter "D" should be smaller than 2.2mm

Figure 6. Recommended Pick and Place Nozzle Size

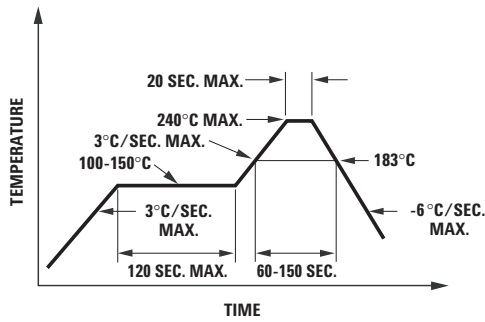
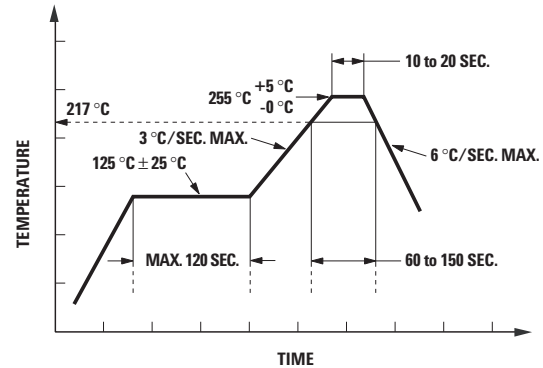

Figure 7a. Recommended SnPb reflow soldering profile



* THE TIME FROM 25 °C TO PEAK TEMPERATURE = 6 MINUTES MAX.

Figure 7b. Recommended Pb-free reflow soldering profile

Note: For detail information on reflow soldering of Avago surface mount LEDs, do refer to Avago Application Note AN 1060 Surface Mounting SMT LED Indicator Components.

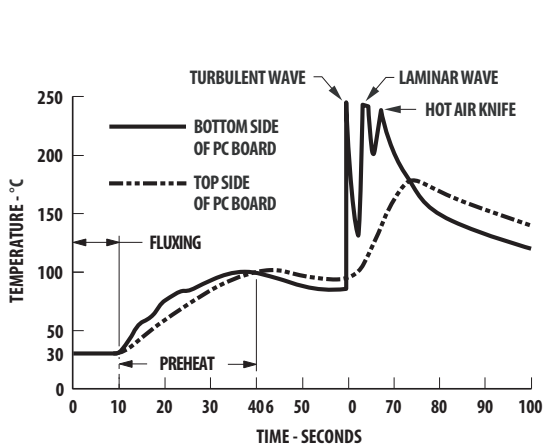

CONVEYOR SPEED = 1.83 M/MIN (6 FT/MIN)
 PREHEAT SETTING = 150°C (100°C PCB)
 SOLDER WAVE TEMPERATURE = 245°C
 AIR KNIFE TEMPERATURE = 390°C
 AIR KNIFE DISTANCE = 1.91 mm (0.25 IN.)
 AIR KNIFE ANGLE = 40°
 SOLDER: SN63; FLUX: RMA

NOTE: ALLOW FOR BOARDS TO BE SUFFICIENTLY COOLED BEFORE EXERTING MECHANICAL FORCE.

Figure 8. Recommended wave soldering profile

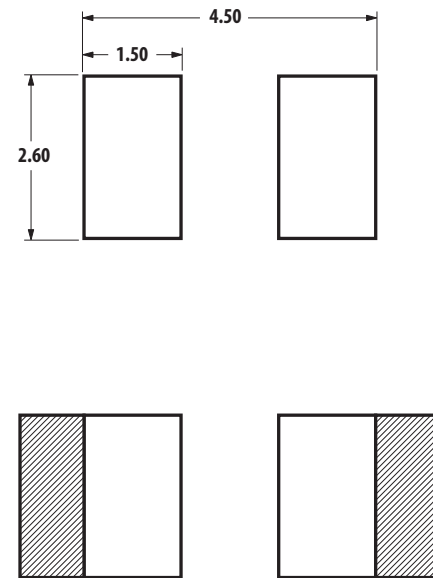

■ SOLDER RESIST

Figure 9. Recommended soldering pad pattern

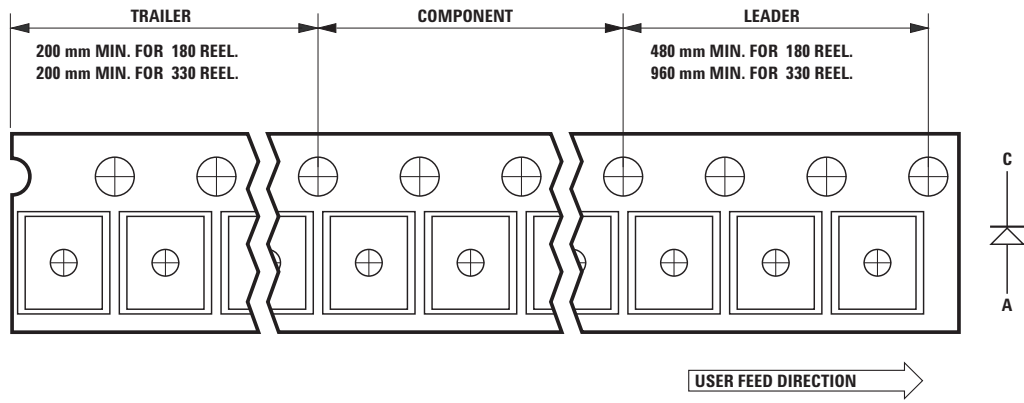

Figure 10. Tape leader and trailer dimension

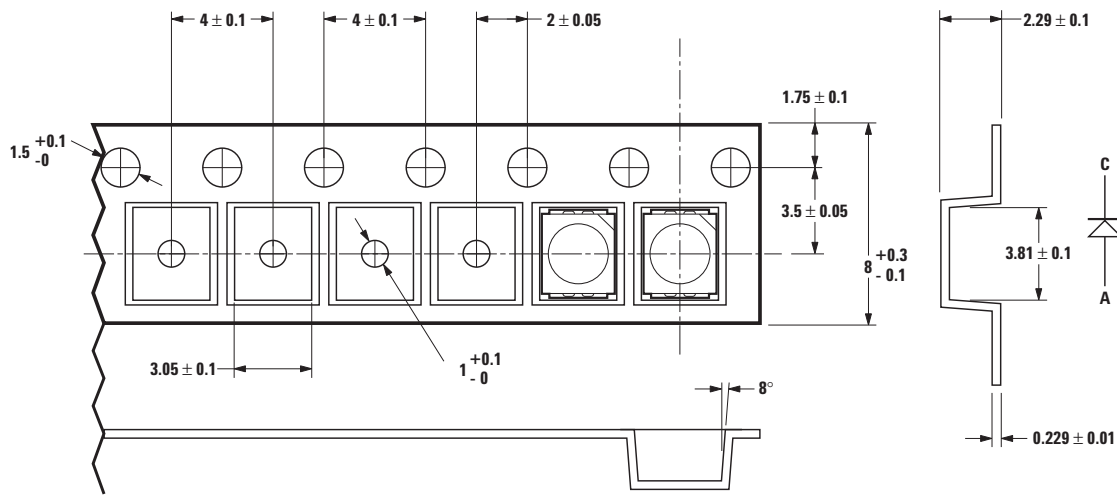

Figure 11. Tape dimension

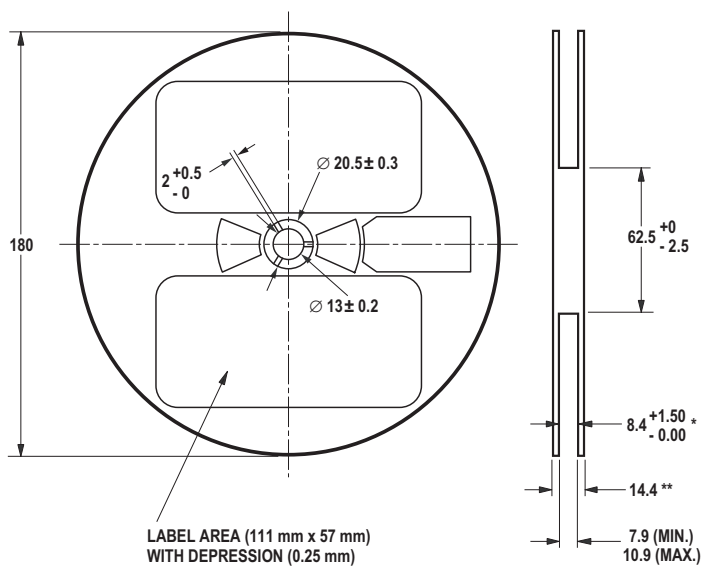

Figure 12. Reel dimensions

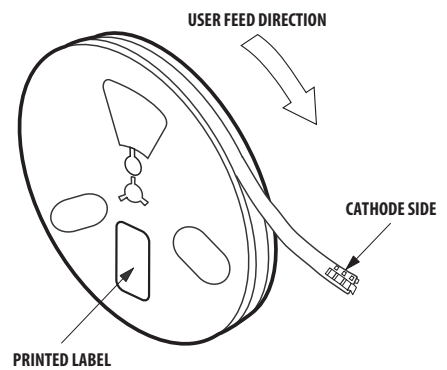

Figure 13. Reeling orientation

Moisture Sensitivity

This product is qualified as Moisture Sensitive Level 2a per Jedec J-STD-020. Precautions when handling this moisture sensitive product is important to ensure the reliability of the product. Do refer to Avago Application Note AN5305 Handling of Moisture Sensitive Surface Mount Devices for details.

A. Storage before use

- Unopen moisture barrier bag (MBB) can be stored at <40°C/90%RH for 12 months. If the actual shelf life has exceeded 12 months and the HIC indicates that baking is not required, then it is safe to reflow the LEDs per the original MSL rating.
- It is not recommended to open the MBB prior to assembly (e.g. for IQC).

B. Control after opening the MBB

- The humidity indicator card (HIC) shall be read immediately upon opening of MBB.
- The LEDs must be kept at <30°C / 60%RH at all time and all high temperature related process including soldering, curing or rework need to be completed within 672 hours.

C. Control for unfinished reel

- For any unused LEDs, they need to be stored in sealed MBB with desiccant or desiccator at <5%RH.

D. Control of assembled boards

- If the PCB soldered with the LEDs is to be subjected to other high temperature processes, the PCB need to be stored in sealed MBB with desiccant or desiccator at <5%RH to ensure no LEDs have exceeded their floor life of 672 hours.

E. Baking is required if:

- "10%" or "15%" HIC indicator turns pink.
- The LEDs are exposed to condition of >30°C / 60% RH at any time.
- The LEDs floor life exceeded 672 hours.

Recommended baking condition: 60±5°C for 20 hours.

Handling Precaution

The encapsulation material of the product is made of silicone for better reliability of the product. As silicone is a soft material, please do not press on the silicone or poke a sharp object onto the silicone. These might damage the product and cause premature failure. During assembly or handling, the unit should be held on the body only. Please refer to Avago Application Note AN 5288 for detail information.

Intensity Bin Select (X₅X₆)

Individual reel will contain parts from one half bin only.

X ₅	Min I _v Bin
X ₆	
0	Full Distribution
3	3 half bins starting from X ₅ 1
4	4 half bins starting from X ₅ 1
5	5 half bins starting from X ₅ 1
7	3 half bins starting from X ₅ 2
8	4 half bins starting from X ₅ 2
9	5 half bins starting from X ₅ 2

Intensity Bin Limits

Bin ID	Min. (mcd)	Max. (mcd)
Q1	71.50	90.00
Q2	90.00	112.50
R1	112.50	140.00
R2	140.00	180.00
S1	180.00	224.00
S2	224.00	285.00
T1	285.00	355.00
T2	355.00	450.00
U1	450.00	560.00
U2	560.00	715.00
V1	715.00	900.00
V2	900.00	1125.00

Tolerance of each bin limit = ± 12%.

Color Bin Limits

Bin ID		Limits (Chromaticity Coordinates)			
A	x	0.352	0.365	0.365	0.352
	y	0.377	0.395	0.360	0.341
B	x	0.340	0.352	0.352	0.340
	y	0.360	0.377	0.341	0.325
C	x	0.327	0.340	0.340	0.327
	y	0.342	0.360	0.325	0.306
D	x	0.315	0.327	0.327	0.315
	y	0.325	0.342	0.306	0.290
E	x	0.302	0.315	0.315	0.302
	y	0.307	0.325	0.290	0.271
F	x	0.290	0.302	0.302	0.290
	y	0.290	0.307	0.271	0.255

Note: Tolerance for each bin limit = ± 0.02 .

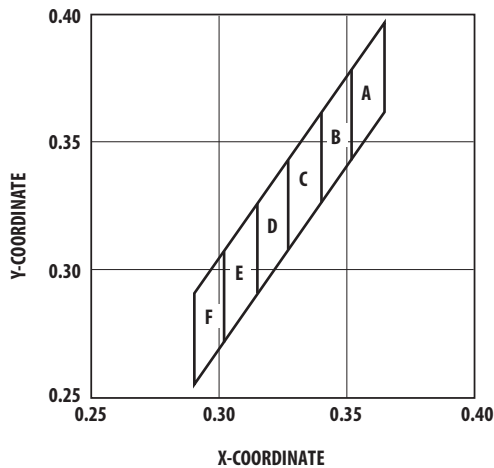

Figure 14. Color Bins

Packaging Option (X₈X₉)

Option	Test Current	Package Type	Reel Size
J1	20 mA	Top Mount	7 inch
J2	10 mA	Top Mount	7 inch
H1	20mA	Reverse Mount	7 inch

Color Bin Select (X₇)

Individual reel will contain parts from one full bin only.

X ₇	
0	Full Distribution
Z	A and B only
Y	B and C only
W	C and D only
V	D and E only
U	E and F only
Q	A, B and C only
P	B, C and D only
N	C, D and E only
M	D, E and F only
1	A, B, C and D only
3	B, C, D and E only
4	C, D, E and F only
5	A, B, C, D and E only
6	B, C, D, E and F only

For product information and a complete list of distributors, please go to our website: www.avagotech.com

Avago, Avago Technologies, and the A logo are trademarks of Avago Technologies in the United States and other countries. Data subject to change. Copyright © 2005-2010 Avago Technologies. All rights reserved. Obsoletes AV01-0645EN AV02-0490EN - January 20, 2010

AVAGO
TECHNOLOGIES