

PART NO.	"A"
	$\pm .015(0.4)$
HMSP-TM-2-01	1/8 (3.2)
HMSP-TM-3-01	3/16 (4.8)
HMSP-TM-4-01	1/4 (6.4)
HMSP-TM-6-01	3/8 (9.5)
HMSP-TM-8-01	1/2 (12.7)
HMSP-TM-10-01	5/8 (15.9)
HMSP-TM-12-01	3/4 (19.1)
HMSP-TM-14-01	7/8 (22.2)

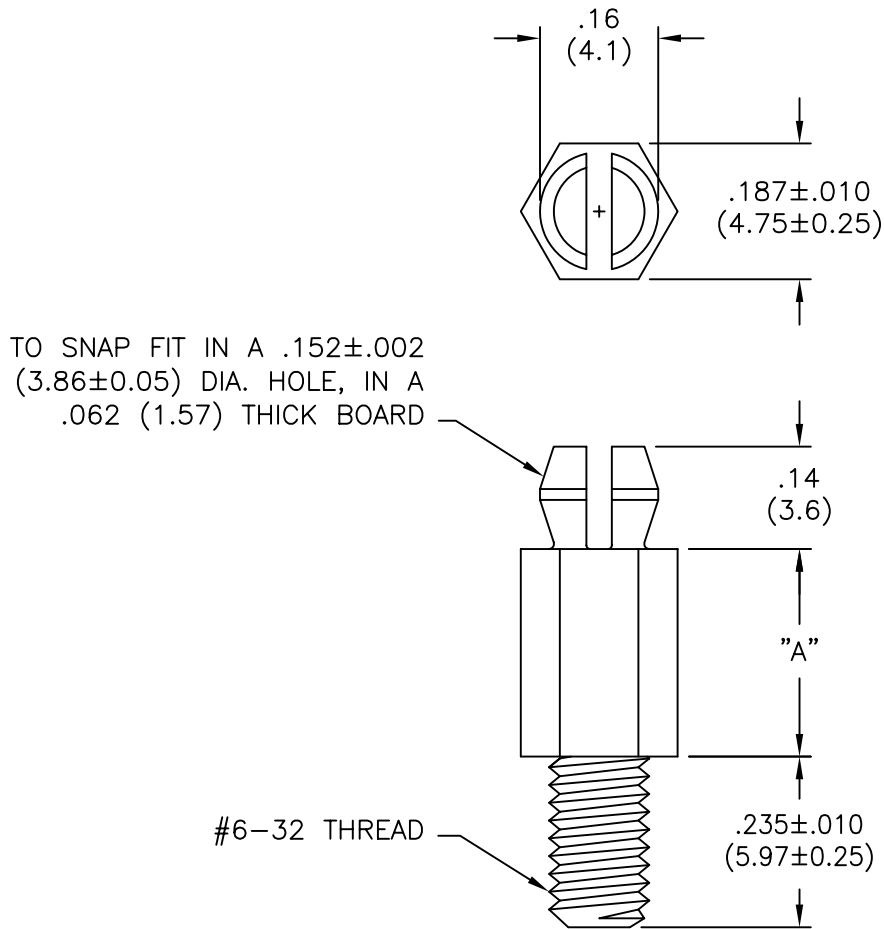

NOTES:

- MATERIAL: NYLON 6/6 (RMS-01).  
FLAME RETARDANT NYLON (RMS-19),  
AVAILABLE BY SPECIAL ORDER ONLY.
- COLOR: NATURAL.

D	CHANGED TO PORTRAIT FORMAT	SM 11.28.01
C	CHANGED FILE NO.	SM 11.06.01
B	MAT'L RMS-19 ADDED	JL 12.10.97
A	CONVERTED TO ACAD	PB 06.22.94
R E V	DESCRIPTION	ENGR DATE

TITLE: HEX MINI SUPPORT POST THREADED MALE



DWG IN  
IN (MM)



FINAL

TOLERANCES UNLESS NOTED .XX=±.010 .XXX=±.005 FRAC=±1/64 ANG=1°	FILE # HMSP-TM	DWN: P.B.	APP:	PART # SEE TABLE	PRINT TYPE CA
	MAT'L: SEE NOTES	DT: 06-22-94	DT:		
	RE: RICHCO, INC.	RICHCO INC. PO BOX 804238, CHICAGO, 60680 (773) 539-4060			