

LTR	REVISION	DATE	APPD
-	RELEASED	10-07-96	
A	RVSD PER ECR 022598-JK08	02-26-98	SA
B	RVSD PER ECR 041202-JH01	04-19-02	JB
C	RVSD PER ECR 052103-JH01	05-30-03	WB

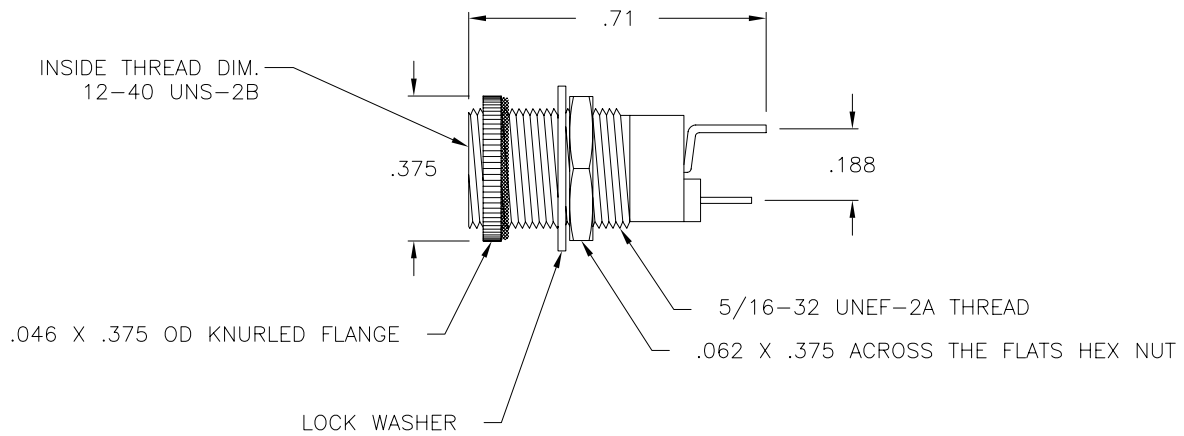
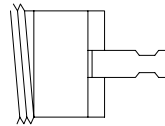

NOTES:

- MATERIAL: CASE - BRASS, NICKEL PLATED
MOUNTING HARDWARE - BRASS, NICKEL PLATED
TERMINALS - BRASS, GOLD PLATED
INSULATION - HIGH DIELECTRIC PLASTIC
- FINISH: HLD2010 - BRIGHT NICKEL
HLD2020 - BLACK NICKEL

LED[®]
LEDTRONICS,™ INC.
23105 KASHIWA COURT
TORRANCE, CA 90505

-PROPRIETARY-
This document contains Proprietary information of LEDTRONICS, INC. It may not be copied, used or disclosed for any purpose without the prior express written consent of LEDTRONICS, INC.

.XXX ± .010 TOLERANCE PER ANSI-Y14.5
.XX ± .025 (UNLESS OTHERWISE STATED)
ANGLES ± 0°,30'
FRACT. ± 1/32

TITLE **HLDR HLD2010, HLDR HLD2020 (ADJUSTABLE)**

DWG NO	SCALE	SHEET	DATE
CMHD0029	2:1	1 OF 1	10-07-96
CODE IDENT NO.	DWG BY	CHK BY	QA
8Z410	MRM		JCH
MFG	CUSTOMER	DATE	
SB	GENERIC	06-04-03	06-04-03