

LTR	REVISION	DATE	APPD
-	RELEASED	05-12-09	

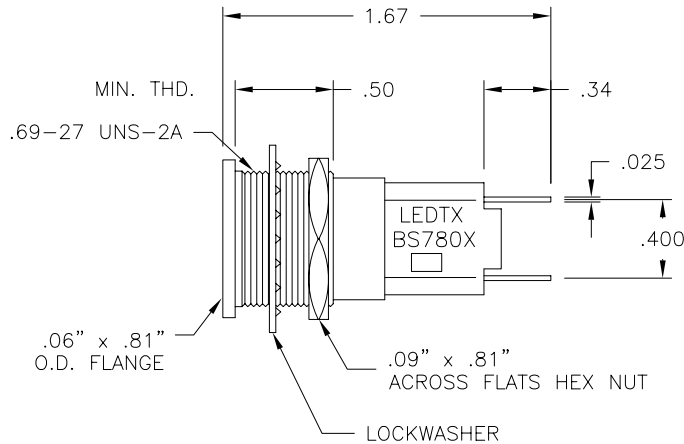
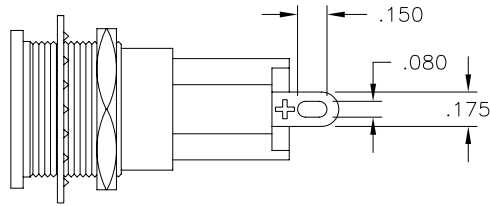

HOLDER (SOLDER TERMINAL)
 FRONT MOUNTING .69" CLEARANCE HOLE
 PART NO.: BS780 (SILVER BEZEL)
 BS780B (BLACK BEZEL)

HOLDER MATERIALS

- BODY BRASS - POLISHED CHROME OR WITH NICKEL FINISH
- HEX NUT BRASS - POLISHED CHROME OR WITH NICKEL FINISH
- LOCK WASHER BRONZE - WHITE NICKEL FINISH
- SOLDER TERM. BRASS - HOT TINNED
- WT. 0.04 LB



BREAKDOWN VOLTAGE

KILOVOLTS DC	KILOVOLTS AC
3.7	5.0

REVISION NOTIFICATION	
<input type="checkbox"/> PMA	
<input type="checkbox"/> UL	
<input type="checkbox"/> CUSTOMER _____	
<input type="checkbox"/> OTHER	



-PROPRIETARY-
 This document contains Proprietary information of LEDTRONICS, INC. It may not be copied, used or disclosed for any purpose without the prior express written consent of LEDTRONICS, INC.

.XXX ± .010 TOLERANCE PER ANSI-Y14.5
 .XX ± .025 (UNLESS OTHERWISE STATED)
 ANGLES ± 0°,30'
 FRACT. ± 1/32

TITLE					
HLDR-BS780 HLDR-BS780B					
DWG NO	SCALE	SHEET	DATE		
CMHD0134-CUST	1:1	1 OF 1	05-12-09		
CODE IDENT NO.	DWG BY	CHK BY	QA	MFG	R&D
8Z410	GP 05-12-09	PL 05-12-09			