

GENERAL DESCRIPTION

The HI-3588 from Holt Integrated Circuits is a silicon gate CMOS device for interfacing a Serial Peripheral Interface (SPI) enabled microcontroller to an ARINC 429 serial bus. The device provides one receiver with user-programmable label recognition for any combination of 256 possible labels, a 32 by 32 Receive FIFO and an analog line receiver. Receive FIFO status can be monitored using the programmable external interrupt pin, or by polling the HI-3588 Status Register. Other features include the ability to switch the bit-significance of ARINC 429 labels. The ARINC input pins are available with different input resistance values to provide flexibility when adding external lightning protection circuitry.

The Serial Peripheral Interface minimizes the number of host interface signals allowing for a small footprint device which can be interfaced to a wide variety of industry-standard microcontrollers supporting SPI. Alternatively, the SPI signals may be controlled using just four general purpose I/O port pins from a microcontroller or custom FPGA. The SPI and all control signals are CMOS and TTL compatible and support 3.3V or 5V operation.

The HI-3588 checks received data against ARINC 429 electrical, timing and protocol requirements. ARINC 429 databus timing comes from a 1 MHz clock input, or an internal counter can derive it from higher clock frequencies having certain fixed values, possibly the external host processor clock.

FEATURES

- ARINC specification 429 compliant
- 3.3V or 5.0V logic supply operation
- On-chip analog line receiver connects directly to ARINC 429 bus
- Programmable label recognition for 256 labels
- 32 x 32 Receive Data FIFO
- Programmable data rate selection
- High-speed, four-wire Serial Peripheral Interface
- Label bit-order control
- Parity checking may be disabled to allow 32-bit data reception
- Low power
- Industrial & extended temperature ranges

PIN CONFIGURATIONS (Top View)

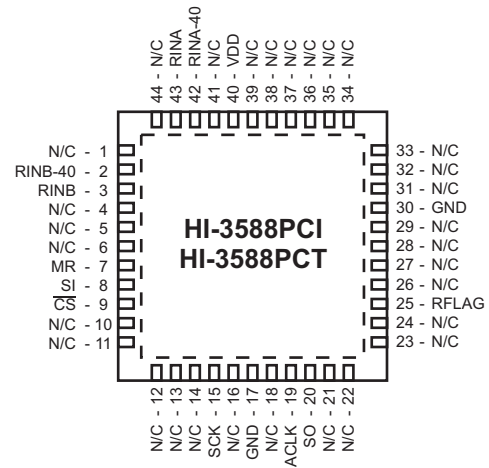

**44 - Pin Plastic 7mm x 7mm
Chip-Scale Package (QFN)**

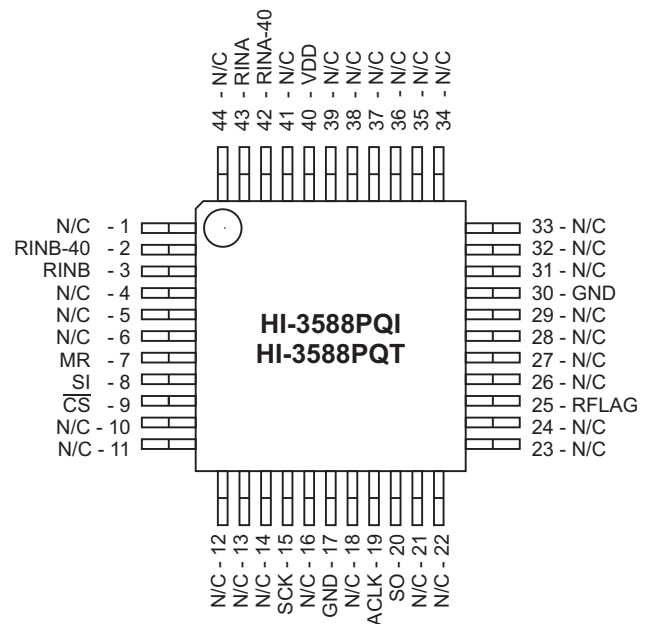

44 - Pin Plastic Quad Flat Pack (PQFP)

BLOCK DIAGRAM

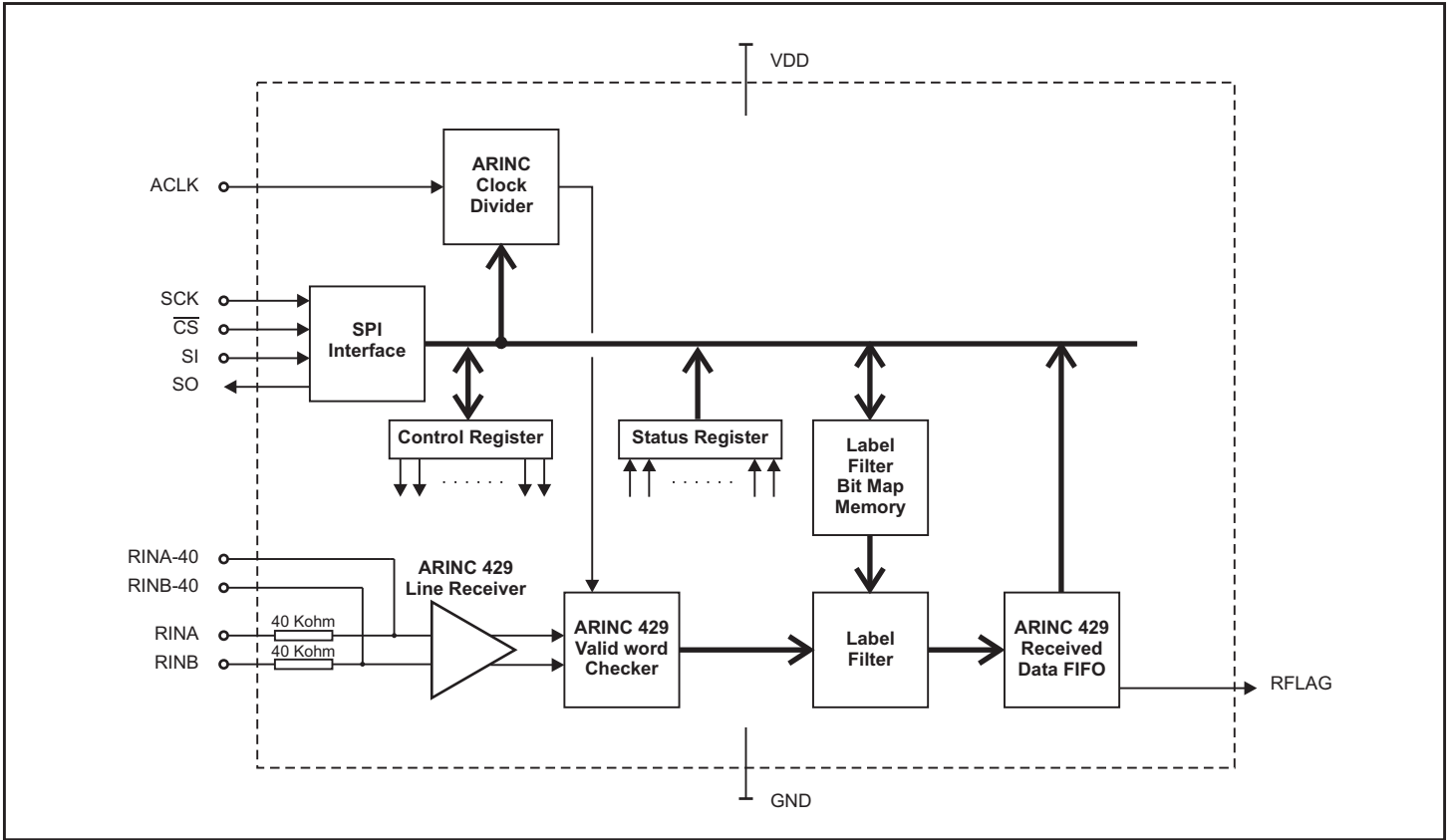

PIN DESCRIPTIONS

SIGNAL	FUNCTION	DESCRIPTION	INTERNAL PULL UP / DOWN
RINB	INPUT	ARINC receiver negative input. Direct connection to ARINC 429 bus	
RINB-40	INPUT	Alternate ARINC receiver negative input. Requires external 40K ohm resistor	
MR	INPUT	Master Reset. A positive pulse clears the Receiver data FIFO and flags	10K ohm pull-down
SI	INPUT	SPI interface serial data input	10K ohm pull-down
\overline{CS}	INPUT	Chip select. Data is shifted into SI and out of SO when \overline{CS} is low.	10K ohm pull-up
SCK	INPUT	SPI Clock. Data is shifted into or out of the SPI interface using SCK	10K ohm pull-down
GND	POWER	Chip 0V supply. Note BOTH GND pins MUST be connected	
ACLK	INPUT	Master timing source for the ARINC 429 receiver	10K ohm pull-down
SO	OUTPUT	SPI interface serial data output	
RFLAG	OUTPUT	Goes high when ARINC 429 receiver FIFO is empty (CR15=0), or full (CR15=1)	
VDD	POWER	3.3V or 5.0V logic power	
RINA-40	INPUT	Alternate ARINC receiver positive input. Requires external 40K ohm resistor	
RINA	INPUT	ARINC receiver positive input. Direct connection to ARINC 429 bus	

INSTRUCTIONS

Instruction op codes are used to read, write and configure the HI-3588A. When \overline{CS} goes low, the next 8 clocks at the SCK pin shift an instruction op code into the decoder, starting with the first positive edge. The op code is fed into the SI pin, most significant bit first.

For write instructions, the most significant bit of the data word must immediately follow the instruction op code and is clocked into its register on the next rising SCK edge. Data word length varies depending on word type written: 16-bit writes to Control Register, 32-bit ARINC word writes to transmit FIFO or 256-bit writes to the label-matching enable/disable table.

For read instructions, the most significant bit of the requested data word appears at the SO pin after the last op code bit is clocked into the decoder, at the next falling SCK edge. As in write instructions, data field bit-length varies with read instruction type.

Table 1 lists all instructions. Instructions that perform a reset or set are executed after the last SI bit is received while \overline{CS} is still low.

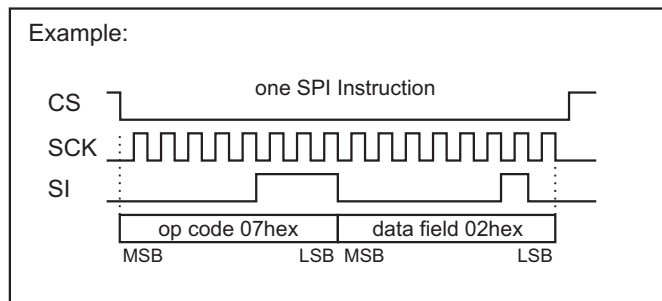

TABLE 1. DEFINED INSTRUCTION OP CODES

OP CODE Hex	DATA FIELD	DESCRIPTION
00	None	No instruction implemented
01	None	After the 8th op-code bit is received, perform Master Reset (MR)
02	None	After the 8th op-code bit is received, reset all label selections
03	None	After the 8th op-code bit is received, set all the label selections
04	8 bits	Reset label at address specified in data field
05	8 bits	Set label at address specified in data field
06	256 bits	Starting with label FF hex, consecutively set or reset each label in descending order. For example, a Data Field pattern starting with 1011 will set labels FF, FD, and FC hex and reset label FE hex.
07	8 bits	Programs a division of the ACLK input. If the divided ACLK frequency is 1 MHz and Control Register bit CR1 is set, the ARINC receiver operates from the divided ACLK clock. Allowable values for division rate are X1, X2, X4, X8, or XA hex. Any other programmed value results in no clock. Note: ACLK input frequency and division ratio must result in 1 MHz clock.
08	32 bits	Read the next word in the Receive FIFO. If the FIFO is empty, it will read zeros
09	None	No instruction implemented
0A	8 bits	Read the Status Register
0B	16 bits	Read the Control Register
0C	8 bits	Read the ACLK divide value programmed previously using op code 07 hex
0D	256 bits	Read the Label look-up memory table consecutively starting with address FF hex
0E	None	No instruction implemented
0F	None	No instruction implemented
10	16 bits	Write the Control Register

FUNCTIONAL DESCRIPTION

CONTROL WORD REGISTER

The HI-3588 contains a 16-bit Control Register which is used to configure the device. Control Register bits CR15 - CR0 are loaded from a 16-bit data value appended to SPI instruction 10 hex. The Control Register contents may be read using SPI instruction 0B hex. Each bit of the Control Register has the following function:

CR Bit	FUNCTION	STATE	DESCRIPTION
CR0 (LSB)	Receiver Data Rate Select	0	Data rate = CLK/10 (ARINC 429 High-Speed)
		1	Data rate = CLK/80 (ARINC 429 Low-Speed)
CR1	ARINC Clock Source Select	0	ARINC CLK = ACLK input frequency
		1	ARINC CLK = ACLK divided by the value programmed with SPI Instruction 07 hex
CR2	Enable Label Recognition	0	Label recognition disabled
		1	Label recognition enabled
CR3	-	X	Not used
CR4	Receiver Parity Check Enable	0	Receiver parity check disabled
		1	Receiver odd parity check enabled
CR5	Receiver Enable	0	Disable receiver. The HI-3588 ignores all ARINC 429 data bus traffic
		1	Normal operation
CR6	Receiver Decoder	0	Receiver decoder disabled
		1	ARINC bits 10 and 9 must match CR7 and CR8
CR7	-	-	If receiver decoder is enabled, the ARINC bit 10 must match this bit
CR8	-	-	If receiver decoder is enabled, the ARINC bit 9 must match this bit
CR9	-	X	Not used
CR10	-	X	Not used
CR11	ARINC Label Bit Order	0	Label bit order reversed (See Table 2)
		1	Label bit order same as received (See Table 2)
CR12	-	X	Not used
CR13	-	X	Not used
CR14	-	X	Not used
CR15 (MSB)	RFLAG Definition	0	FLAG goes high when receive FIFO is empty
		1	RFLAG goes high when receive FIFO is full

STATUS REGISTER

The HI-3588 contains an 8-bit Status Register which can be interrogated to determine status of the ARINC Receive FIFO. The Status Register is read using SPI instruction 0A hex. Unused bits are undefined and may be read as either "1" or "0". The following table defines the Status Register bits.

SR Bit	FUNCTION	STATE	DESCRIPTION
SR0 (LSB)	Receive FIFO Empty	0	Receiver FIFO contains valid data Sets to One when all data has been read. RFLAG pin reflects the state of this bit when CR15="0"
		1	Receiver FIFO is empty
SR1	Receive FIFO Half Full	0	Receiver FIFO holds less than 16 words
		1	Receiver FIFO holds at least 16 words
SR2	Receive FIFO Full	0	Receiver FIFO not full. RFLAG pin reflects the state of this bit when CR15="1"
		1	Receiver FIFO full. To avoid data loss, the FIFO must be read within one ARINC word period
SR3	Not used	X	Undefined
SR4	Not used	X	Undefined
SR5	Not used	X	Undefined
SR6	Not used	0	Always "0"
SR7 (MSB)	Not used	0	Always "0"

ARINC 429 DATA FORMAT

Control Register bit CR11 controls how individual bits in the received ARINC word are mapped to the HI-3588 SPI data word bits during data read or write operations. The following table describes this mapping:

Table 2. SPI / ARINC bit-mapping												
SPI Order	1	2 - 22	23	24	25	26	27	28	29	30	31	32
ARINC bit	32	31 - 11	10	9	1	2	3	4	5	6	7	8
CR11=0	Parity	Data	SDI	SDI	Label (MSB)	Label	Label	Label	Label	Label	Label	Label (LSB)
ARINC bit	32	31 - 11	10	9	8	7	6	5	4	3	2	1
CR11=1	Parity	Data	SDI	SDI	Label (LSB)	Label	Label	Label	Label	Label	Label	Label (MSB)

FUNCTIONAL DESCRIPTION (cont.)

ARINC 429 RECEIVER

ARINC BUS INTERFACE

Figure 1 shows the input circuit for the ARINC 429 line receiver. The ARINC 429 specification requires the following detection levels:

STATE	DIFFERENTIAL VOLTAGE
ONE	+6.5 Volts to +13 Volts
NULL	+2.5 Volts to -2.5 Volts
ZERO	-6.5 Volts to -13 Volts

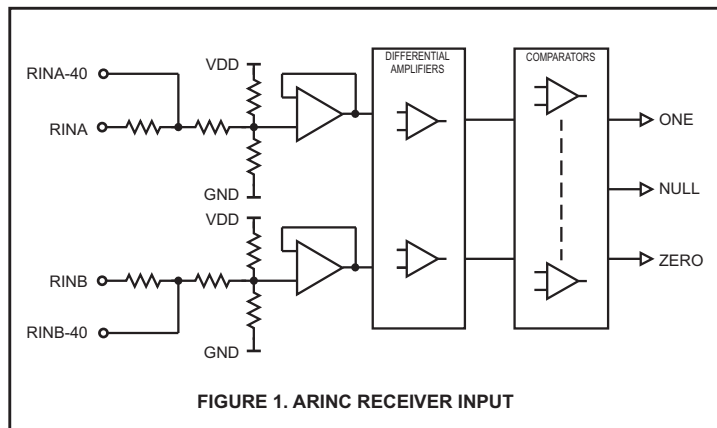

The HI-3588 guarantees recognition of these levels with a common mode voltage with respect to GND less than $\pm 30V$ for the worst case condition (3.15V supply and 13V signal level). Design tolerances guarantee detection of the above levels, so the actual acceptance ranges are slightly larger. If the ARINC signal (including nulls) is outside the differential voltage ranges, the HI-3588 receiver rejects the data.

RECEIVER LOGIC OPERATION

Figure 2 is a block diagram showing receiver logic.

BIT TIMING

The ARINC 429 specification defines the following timing tolerances for received data:

	HIGH SPEED	LOW SPEED
BIT RATE	100K BPS $\pm 1\%$	12K -14.5K BPS
PULSE RISE TIME	1.5 \pm 0.5 μ sec	10 \pm 5 μ sec
PULSE FALL TIME	1.5 \pm 0.5 μ sec	10 \pm 5 μ sec
PULSE WIDTH	5 μ sec $\pm 5\%$	34.5 to 41.7 μ sec

The HI-3588 accepts signals within these tolerances and rejects signals outside these tolerances. Receiver logic achieves this as described below:

1. An accurate 1MHz clock source is required to validate the receive signal timing. Less than 0.1% error is recommended.
2. The receiver uses three separate 10-bit sampling shift registers for Ones detection, Zeros detection and Null detection. When the input signal is within the differential voltage range for any shift register's state (One Zero or Null) sampling clocks a high bit into that register. When the receive signal is outside the differential voltage range defined for any shift reg-

ister, a low bit is clocked. Only one shift register can clock a high bit for any given sample. All three registers clock low bits if the differential input voltage is between defined state voltage bands.

Valid data bits require at least three consecutive One or Zero samples (three high bits) in the upper half of the Ones or Zeros sampling shift register, and at least three consecutive Null samples (three high bits) in the lower half of the Null sampling shift register within the data bit interval.

A word gap Null requires at least three consecutive Null samples (three high bits) in the upper half of the Null sampling shift register and at least three consecutive Null samples (three high bits) in the lower half of the Null sampling shift register. This guarantees the minimum pulse width.

3. To validate the receive data bit rate, each bit must follow its preceding bit by not less than 8 samples and not more than 12 samples. With exactly 1MHz input clock frequency, the acceptable data bit rates are:

	HIGH SPEED	LOW SPEED
DATA BIT RATE MIN	83K BPS	10.4K BPS
DATA BIT RATE MAX	125K BPS	15.6K BPS

4. Following the last data bit of a valid reception, the Word Gap timer samples the Null shift register every 10 input clocks (every 80 clocks for low speed). If a Null is present, the Word Gap counter is incremented. A Word Gap count of 3 enables the next reception.

RECEIVER PARITY

The receiver parity circuit counts Ones received, including the parity bit. If the result is odd, a "0" appears in the 32nd bit.

RETRIEVING DATA

Once 32 valid bits are recognized, the receiver logic generates an End of Sequence (EOS). Depending on the state of Control Register bits CR2, and CR6 through CR8, the received 32-bit ARINC word is then checked for correct decoding and label match before it is loaded into the 32 x 32 Receive FIFO. ARINC words that do not match required 9th and 10th ARINC bit and do not have a label match are ignored and are not loaded into the Receive FIFO. The table below describes this operation.

CR2	ARINC word matches Enabled label	CR6	ARINC word bits 10, 9 match CR7,8	FIFO
0	X	0	X	Load FIFO
1	No	0	X	Ignore data
1	Yes	0	X	Load FIFO
0	X	1	No	Ignore data
0	X	1	Yes	Load FIFO
1	Yes	1	No	Ignore data
1	No	1	Yes	Ignore data
1	No	1	No	Ignore data
1	Yes	1	Yes	Load FIFO

FUNCTIONAL DESCRIPTION (cont.)

Once a valid ARINC word is loaded into the FIFO, the EOS signal clocks the Data Ready flip-flop to a "1" and Status Register bit 0 (SR0) to a "0". The SR0 bit remains low until the Receive FIFO is empty. Each received ARINC word is retrieved via the SPI interface using SPI instruction 08 hex to read a single word.

Up to 32 ARINC words may be held in the Receive FIFO. Status register bit 2 (SR2) goes high when the Receive FIFO is full. Failure to unload the Receive FIFO when full causes additional received valid ARINC words to overwrite Receive FIFO location 32.

A FIFO half-full flag (SR1) is high when the Receive FIFO contains 16 or more ARINC words. SR1 may be interrogated by the system's external microprocessor, allowing a 16 word data retrieval routine to be performed.

LABEL RECOGNITION

The user loads the 256-bit label look-up table to specify which 8-bit incoming ARINC labels are captured by the receiver, and which are discarded. Setting a "1" in the look-up table enables processing of received ARINC words containing the corresponding label. A "0" in the look-up table causes discard of received ARINC words containing the label. The 256-bit look-up table is loaded using SPI op codes 02 hex, 03 hex or 06 hex, as described in Table 1. After the look-up table is initialized, set Control Register bit CR2 to enable label recognition.

If label recognition is enabled, the receiver compares the label in each new ARINC word against the stored look-up table. If a label match is found, the received word is processed. If no match occurs, the new ARINC word is discarded and no indicators of

received ARINC data are presented.

READING THE LABEL LOOK-UP TABLE

The contents of the Label Look-up table may be read via the SPI interface using instruction 0D hex as described in Table 1.

LINE RECEIVER INPUT PINS

The HI-3588 has two sets of Line Receiver input pins, RINA/B and RINA/B-40. Only one pair may be used to connect to the ARINC 429 bus. The unused pair must be left floating. The RINA/B pins may be connected directly to the ARINC 429 bus. The RINA/B-40 pins require external 40K ohm resistors in series with each ARINC input. These do not affect the ARINC receiver thresholds. By keeping excessive voltage outside the device, this option is helpful in applications where lightning protection is required.

When using the RINA/B-40 pins, each side of the ARINC bus must be connected through a 40K ohm series resistor in order for the chip to detect the correct ARINC levels. The typical 10 Volt differential signal is translated and input to a window comparator and latch. The comparator levels are set so that with the external 40K ohm resistors, they are just below the standard 6.5 volt minimum ARINC data threshold and just above the standard 2.5 volt maximum ARINC null threshold.

Please refer to the Holt AN-300 Application Note for additional information and recommendations on lightning protection of Holt line drivers and line receivers.

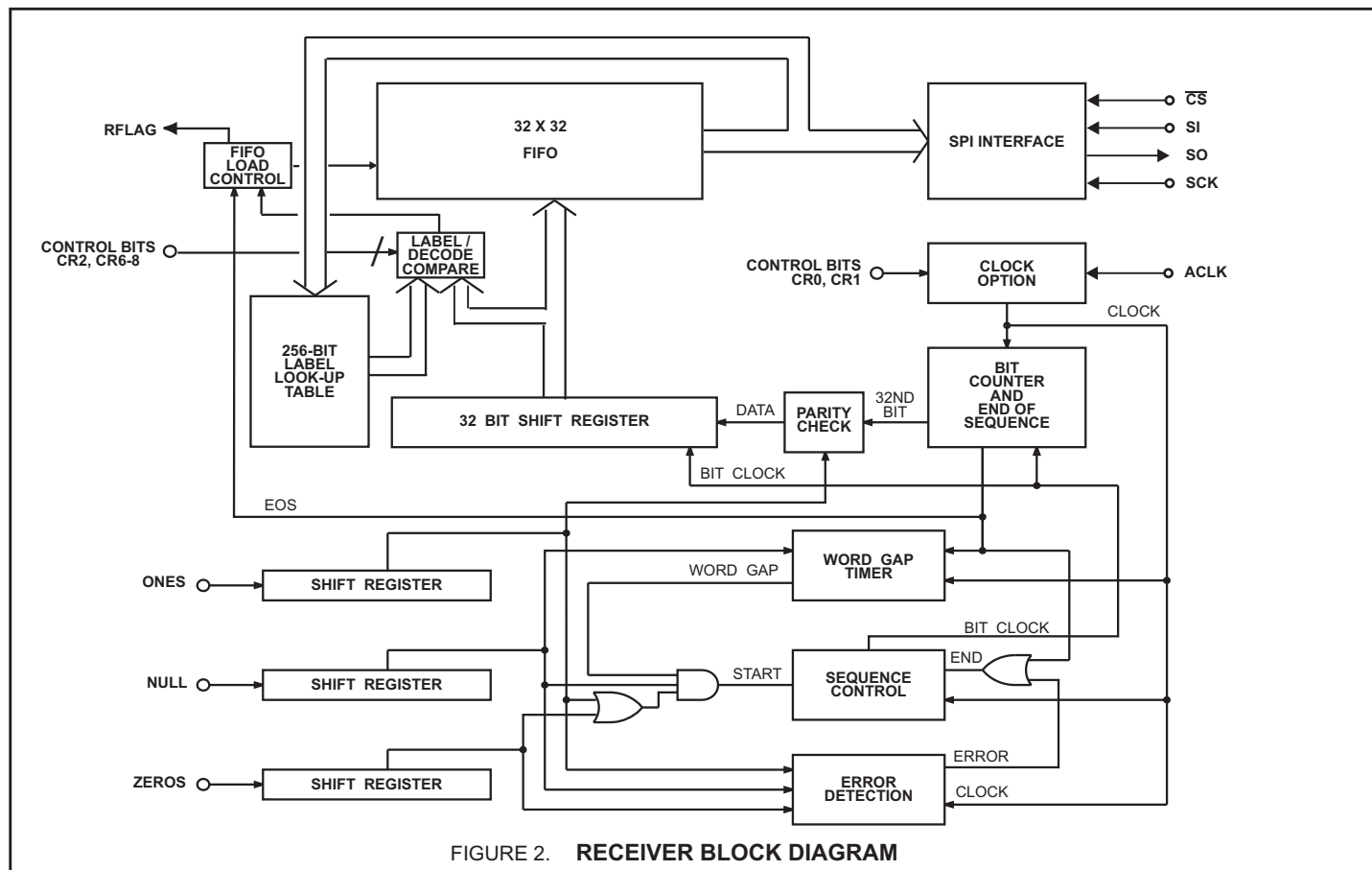

FIGURE 2. RECEIVER BLOCK DIAGRAM

FUNCTIONAL DESCRIPTION (cont.)

MASTER RESET (MR)

Assertion of Master Reset causes immediate termination of data reception. The receive FIFO, Status Register FIFO flags and the FIFO status RFLAG pin is also cleared. The Control Register is not affected by Master Reset.

TIMING DIAGRAMS

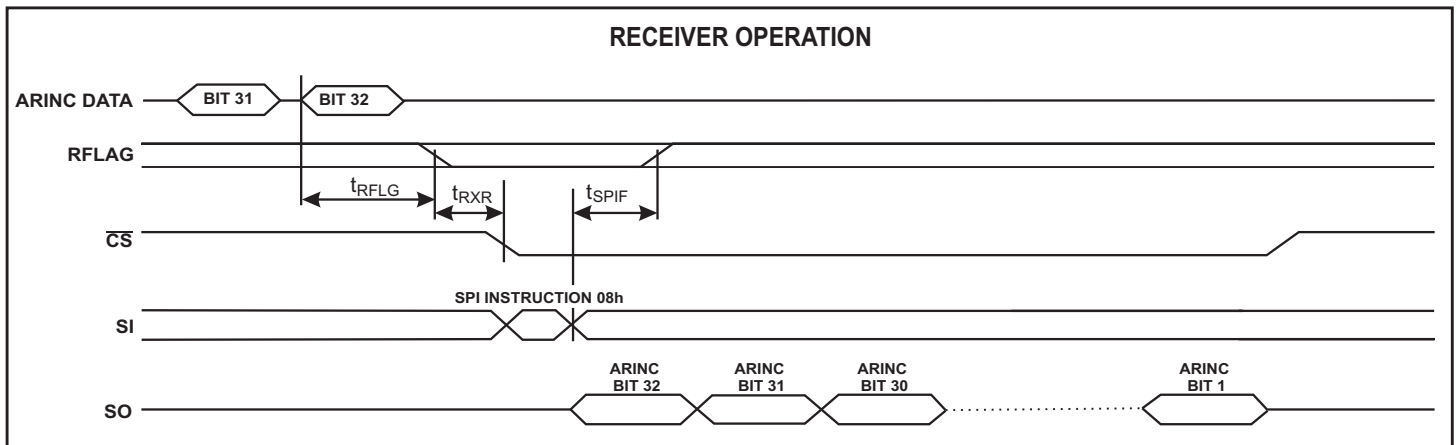
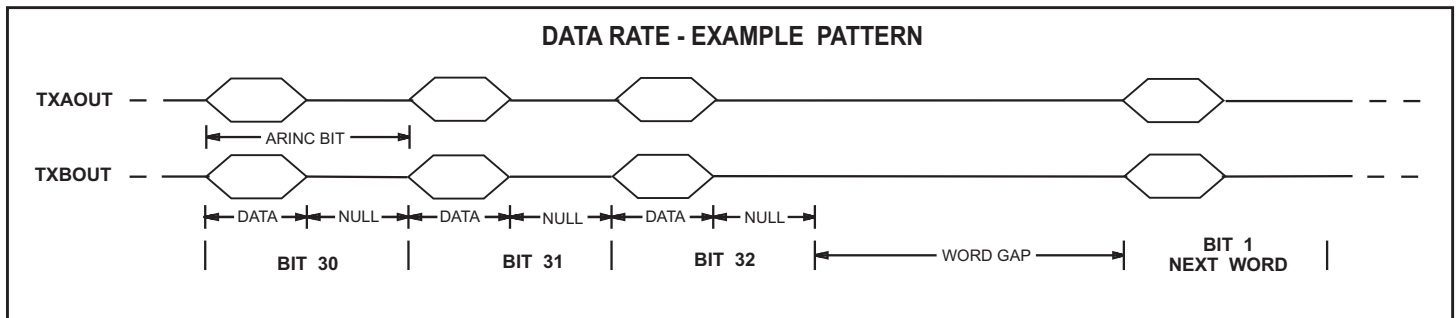
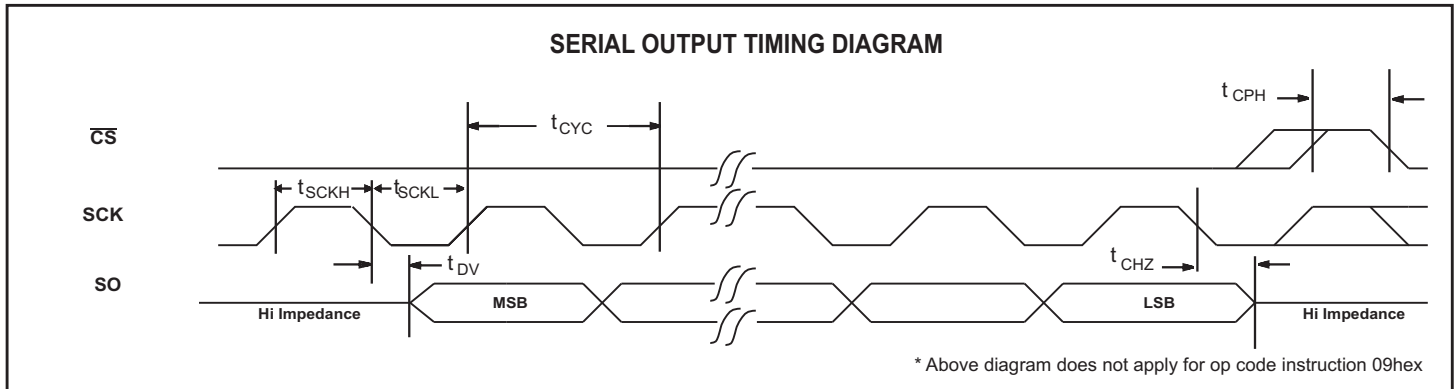
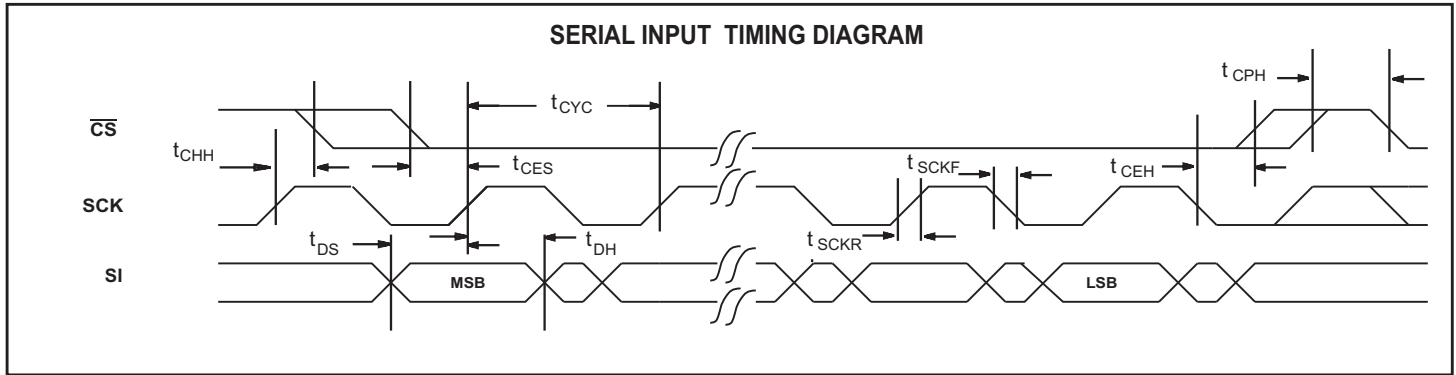

ABSOLUTE MAXIMUM RATINGS

Supply Voltages V_{DD} -0.3V to +7.0V	Power Dissipation at 25°C Plastic Quad Flat Pack 1.5 W, derate 10mW/°C
Voltage at pins RINA, RINB -120V to +120V	DC Current Drain per pin $\pm 10\text{mA}$
Voltage at any other pin -0.3V to $V_{DD} + 0.3\text{V}$	Storage Temperature Range -65°C to +150°C
Solder temperature (Leads) 280°C for 10 seconds (Package) 220°C	Operating Temperature Range (Industrial): -40°C to +85°C (Hi-Temp): -55°C to +125°C

NOTE: Stresses above those listed under "Absolute Maximum Ratings" may cause permanent damage to the device. These are stress ratings only. Functional operation of the device at these or any other conditions above those indicated in the operational sections of the specifications is not implied. Exposure to absolute maximum rating conditions for extended periods may affect device reliability.

DC ELECTRICAL CHARACTERISTICS

$V_{DD} = 3.3\text{V}$ or 5.0V , $GND = 0\text{V}$, $T_A =$ Operating Temperature Range (unless otherwise specified).

PARAMETER	SYMBOL	CONDITIONS	LIMITS			UNIT	
			MIN	TYP	MAX		
ARINC INPUTS - Pins RINA, RINB, RINA-40 (with external 40KOhms), RINB-40 (with external 40KOhms)							
Differential Input Voltage: (RINA to RINB)	ONE	V_{IH}	Common mode voltages less than $\pm 30\text{V}$ with respect to GND	6.5	10.0	13.0	V
	ZERO	V_{IL}		-13.0	-10.0	-6.5	V
	NULL	V_{NUL}		-2.5	0	2.5	V
Input Resistance:	Differential	R_i		-	140	-	K Ω
	To GND	R_G		-	140	-	K Ω
	To V_{DD}	R_H		-	100	-	K Ω
Input Current:	Input Sink	I_{IH}		-450		200	μA
	Input Source	I_{IL}					μA
Input Capacitance: (Guaranteed but not tested)	Differential	C_i	(RINA to RINB)			20	pF
	To GND	C_G				20	pF
	To V_{DD}	C_H				20	pF
LOGIC INPUTS							
Input Voltage:	Input Voltage HI	V_{IH}		80% V_{DD}			V
	Input Voltage LO	V_{IL}				20% V_{DD}	V
Input Current:	Input Sink	I_{IH}		-1.5		1.5	μA
	Input Source	I_{IL}					μA
	Pull-down Current (MR, SI, SCK, ACLK pins)	I_{PD}					250
	Pull-up Current (CS Pin)	I_{PU}		-600		-300	μA
LOGIC OUTPUTS							
Output Voltage:	Logic "1" Output Voltage	V_{OH}	$I_{OH} = -100\mu\text{A}$	90% V_{DD}			V
	Logic "0" Output Voltage	V_{OL}	$I_{OL} = 1.0\text{mA}$			10% V_{DD}	V
Output Current: (All Outputs & Bi-directional Pins)	Output Sink	I_{OL}	$V_{OUT} = 0.4\text{V}$	1.6		-1.0	mA
	Output Source	I_{OH}	$V_{OUT} = V_{DD} - 0.4\text{V}$				mA
Output Capacitance:		C_o			15		pF
Operating Voltage Range							
	V_{DD}			3.15		5.25	V
Operating Supply Current							
V_{DD}	I_{DD}				2.5	7	mA

AC ELECTRICAL CHARACTERISTICS

VDD = 3.3V or 5.0V, GND = 0V, TA = Operating Temperature Range and fclk=1MHz ±0.1% with 60/40 duty cycle

PARAMETER	SYMBOL	LIMITS			UNITS
		MIN	TYP	MAX	
SPI INTERFACE TIMING					
SCK clock period	tCYC	200			ns
\overline{CS} active after last SCK rising edge	tCHH	20			ns
\overline{CS} setup time to first SCK rising edge	tCES	10			ns
\overline{CS} hold time after last SCK falling edge	tCEH	40			ns
\overline{CS} inactive between SPI instructions	tCPH	35			ns
SPI SI Data set-up time to SCK rising edge	tDS	30			ns
SPI SI Data hold time after SCK rising edge	tDH	30			ns
SCK rise time	tSCKR			10	ns
SCK fall ime	tSCKF			10	ns
SCK pulse width high	tSCKH	90			ns
SCK pulse width low	tSCKL	80			ns
SO valid after SCK falling edge	tDV			130	ns
SO high-impedance after SCK falling edge	tCHZ			100	ns
RECEIVER TIMING					
Delay - Last bit of received ARINC word to RFLAG(Full or Empty) - Hi Speed	tRFLG			16	µs
Delay - Last bit of received ARINC word to RFLAG(Full or Empty) - Lo Speed	tRFLG			126	µs
Received data available to SPI interface. RFLAG to \overline{CS} active	tRXR	0			ns
SPI receiver read or clear FIFO instruction to RFLAG	tSPIF			155	ns

HEAT SINK - CHIP-SCALE PACKAGE ONLY

The HI-3588PCI and HI-3588PCT use a 44-pin plastic chip-scale package. This package has a metal heat sink pad on its bottom surface that is electrically connected to the die. For the HI-3588, the primary advantage of this package is its small size; heat sinking provides little benefit

because HI-3588 dissipation is low. If connected, the heat bottom sink pad should be connected to VDD.

Do not connect heat sink pad to GND.

ORDERING INFORMATION

HI - 3588 **xx x x**

PART NUMBER	LEAD FINISH
Blank	Tin / Lead (Sn / Pb) Solder
F	100% Matte Tin (Pb-free, RoHS compliant)

PART NUMBER	TEMPERATURE RANGE	FLOW	BURN IN
I	-40°C TO +85°C	I	No
T	-55°C TO +125°C	T	No

PART NUMBER	PACKAGE DESCRIPTION
PC	44 PIN PLASTIC CHIP-SCALE, QFN (44PCS)
PQ	44 PIN PLASTIC QUAD FLAT PACK, PQFP (44PTQS)

REVISION HISTORY

P/N	Rev	Date	Description of Change
DS3588	NEW	05/08/08	Initial Release
	A	10/10/08	Revised AC Electrical Characteristics.
	B	05/22/09	Clarified relationship between SPI bit order and the ARINC 429 bit order.
	C	07/02/09	Removed references to V+, V-, which are not connected in this device
	D	02/03/10	Clarified op code 09hex description.
	E	04/20/10	Removed op code 09hex.
	F	05/19/10	Corrected ARINC receiver nomenclature.

44-PIN PLASTIC CHIP-SCALE PACKAGE (QFN)

inches (millimeters)

Package Type: 44PCS

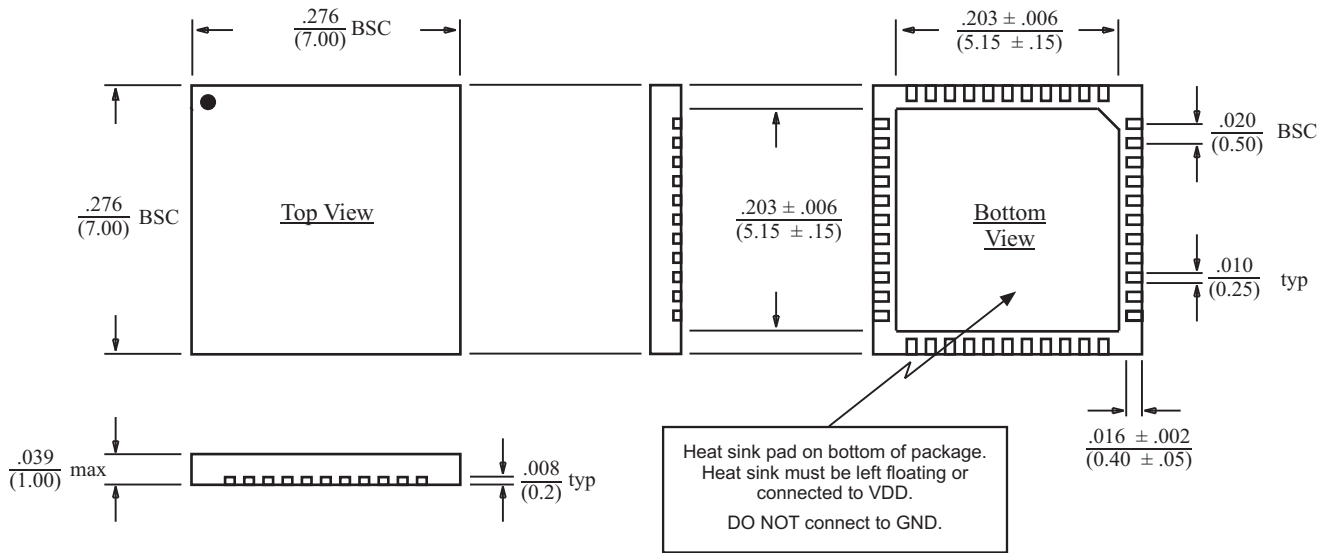

BSC = "Basic Spacing between Centers"
is theoretical true position dimension and has no tolerance. (JEDEC Standard 95)

44-PIN PLASTIC QUAD FLAT PACK (PQFP)

inches (millimeters)

Package Type: 44PTQS

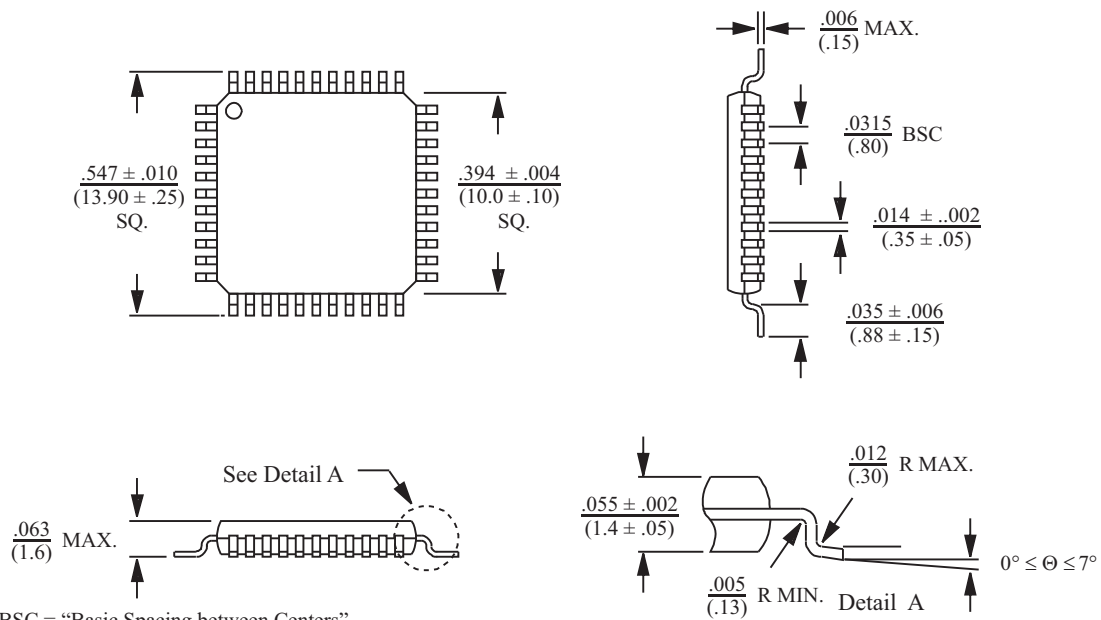

BSC = "Basic Spacing between Centers"
is theoretical true position dimension and has no tolerance. (JEDEC Standard 95)