

GENERAL DESCRIPTION

The HI-3282 is a silicon gate CMOS device for interfacing the ARINC 429 serial data bus to a 16-bit parallel data bus. Two receivers and an independent transmitter are provided. The receiver input circuitry and logic are designed to meet the ARINC 429 specifications for loading, level detection, timing, and protocol. The ARINC inputs of the HI-3282-10 configurations also have internal lightning protection to DO-160D, Level 3. The transmitter section provides the ARINC 429 communication protocol. An external ARINC 429 Line Driver such as the Holt HI-3182 or HI-8585 is required to translate the 5 volt logic outputs to ARINC 429 drive levels.

The 16-bit parallel data bus exchanges the 32-bit ARINC data word in two steps when either loading the transmitter or interrogating the receivers. The data bus interfaces with CMOS and TTL.

Timing of all the circuitry begins with the master clock input, CLK. For ARINC 429 applications, the master clock frequency is 1 MHz.

Each independent receiver monitors the data stream with a sampling rate 10 times the data rate. The sampling rate is software selectable at either 1MHz or 125KHz. The results of a parity check are available as the 32nd ARINC bit.

The transmitter has a First In, First Out (FIFO) memory to store 8 ARINC words for transmission. The data rate of the transmitter is software selectable by dividing the master clock, CLK, by either 10 or 80. The master clock is used to set the timing of the ARINC transmission within the required resolution.

APPLICATIONS

- Avionics data communication
- Serial to parallel conversion
- Parallel to serial conversion

FEATURES

- ARINC specification 429 compatible
- Compatible with Industry-standard alternate parts
- Small footprint 44-pin PQFP package option
- 16-Bit parallel data bus
- Direct receiver interface to ARINC bus
- Internal Lightning Protection of ARINC inputs per DO-160D, Level 3 in -10 configurations
- Timing control 10 times the data rate
- Selectable data clocks
- Automatic transmitter data timing
- Self test mode
- Parity functions
- Low power, single 5 volt supply
- Industrial & extended temperature ranges

PIN CONFIGURATION (Top View)

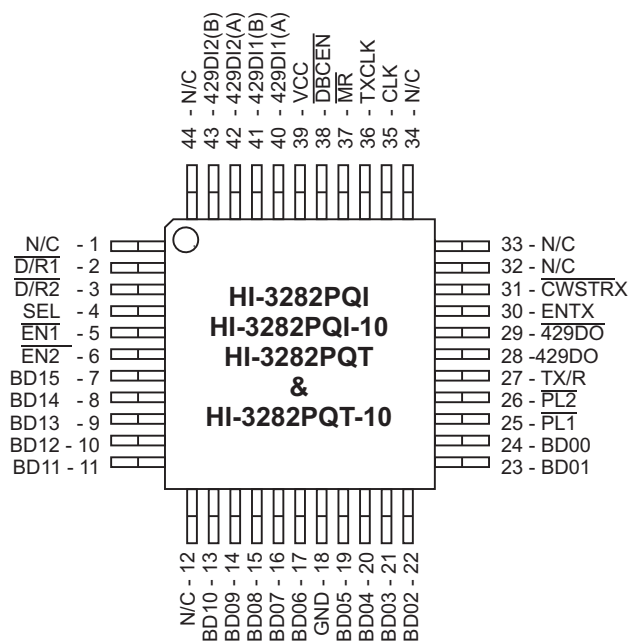

44-Pin Plastic Quad Flat Pack (PQFP)

(See page 10 for additional pin configurations)

PIN DESCRIPTION

SYMBOL	FUNCTION	DESCRIPTION
VCC	POWER	+5V ±5%
429DI1 (A)	INPUT	ARINC receiver 1 positive input
429DI1 (B)	INPUT	ARINC receiver 1 negative input
429DI2 (A)	INPUT	ARINC receiver 2 positive input
429DI2 (B)	INPUT	ARINC receiver 2 negative input
$\overline{D/R1}$	OUTPUT	Receiver 1 data ready flag
$\overline{D/R2}$	OUTPUT	Receiver 2 data ready flag
SEL	INPUT	Receiver data byte selection (0 = BYTE 1) (1 = BYTE 2)
$\overline{EN1}$	INPUT	Data Bus control, enables receiver 1 data to outputs
$\overline{EN2}$	INPUT	Data Bus control, enables receiver 2 data to outputs if $\overline{EN1}$ is high
BD15	I/O	Data Bus
BD14	I/O	Data Bus
BD13	I/O	Data Bus
BD12	I/O	Data Bus
BD11	I/O	Data Bus
BD10	I/O	Data Bus
BD09	I/O	Data Bus
BD08	I/O	Data Bus
BD07	I/O	Data Bus
BD06	I/O	Data Bus
GND	POWER	0 V
BD05	I/O	Data Bus
BD04	I/O	Data Bus
BD03	I/O	Data Bus
BD02	I/O	Data Bus
BD01	I/O	Data Bus
BD00	I/O	Data Bus
$\overline{PL1}$	INPUT	Latch enable for byte 1 entered from data bus to transmitter FIFO.
$\overline{PL2}$	INPUT	Latch enable for byte 2 entered from data bus to transmitter FIFO. Must follow $\overline{PL1}$.
TX/R	OUTPUT	Transmitter ready flag. Goes low when ARINC word loaded into FIFO. Goes high after transmission and FIFO empty.
429DO	OUTPUT	"ONES" data output from transmitter.
$\overline{429DO}$	OUTPUT	"ZEROES" data output from transmitter.
ENTX	INPUT	Enable Transmission
\overline{CWSTR}	INPUT	Clock for control word register
CLK	INPUT	Master Clock input
TX CLK	OUTPUT	Transmitter Clock equal to Master Clock (CLK), divided by either 10 or 80.
\overline{MR}	INPUT	Master Reset, active low
\overline{DBCEN}	INPUT	Data bit control Enable. (Active low, with internal pull up to VDD).

FUNCTIONAL DESCRIPTION

CONTROL WORD REGISTER

The HI-3282 contains 11 data flip flops whose D inputs are connected to the data bus and clocks connected to CWSTR. Each flip flop provides options to the user as follows:

DATA BUS PIN	FUNCTION	CONTROL	DESCRIPTION
BD04	PAREN		Enables parity bit insertion into Transmitter data bit 32
BDO5	SELF TEST	0 = ENABLE	If enabled, an internal connection is made passing 429DO and 429DO to the receiver logic inputs
BDO6	RECEIVER 1 DECODER	1 = ENABLE	If enabled, ARINC bits 9 and, 10 must match the next two control word bits
BD07	-	-	If Receiver 1 Decoder is enabled, the ARINC bit 9 must match this bit
BD08	-	-	If Receiver 1 Decoder is enabled, the ARINC bit 10 must match this bit
BDO9	RECEIVER 2 DECODER	1 = ENABLE	If enabled, ARINC bits 9 and 10 must match the next two control word bits
BD10	-	-	If Receiver 2 Decoder is enabled, then ARINC bit 9 must match this bit
BD11	-	-	If Receiver 2 Decoder is enabled, then ARINC bit 10 must match this bit
BD12	INVERT XMTR PARITY	1 = ENABLE	Logic 0 enables normal odd parity and Logic 1 enables even parity output in transmitter 32nd bit
BD13	XMTR DATA CLK SELECT	0 = ÷10 1 = ÷80	CLK is divided either by 10 or 80 to obtain XMTR data clock
BD14	RCVR DTA CLK SELECT	0 = ÷10 1 = ÷80	CLK is divided either by 10 or 80 to obtain RCVR data clock

ARINC 429 DATA FORMAT

The following table shows the bit positions in exchanging data with the receiver or the transmitter. ARINC bit 1 is the first bit transmitted or received.

BYTE 1																
DATA BUS	BD 15	BD 14	BD 13	BD 12	BD 11	BD 10	BD 09	BD 08	BD 07	BD 06	BD 05	BD 04	BD 03	BD 02	BD 01	BD 00
ARINC BIT	13	12	11	10	9	31	30	32	1	2	3	4	5	6	7	8

BYTE 2																
DATA BUS	BD 15	BD 14	BD 13	BD 12	BD 11	BD 10	BD 09	BD 08	BD 07	BD 06	BD 05	BD 04	BD 03	BD 02	BD 01	BD 00
ARINC BIT	29	28	27	26	25	24	23	22	21	20	19	18	17	16	15	14

RECEIVERS

ARINC BUS INTERFACE

Figure 1 shows the input circuit for each receiver. The ARINC 429 specification requires the following detection levels:

STATE	DIFFERENTIAL VOLTAGE
ONE	+6.5 Volts to +13 Volts
NULL	+2.5 Volts to -2.5 Volts
ZERO	-6.5 Volts to -13 Volts

The HI-3282 guarantees recognition of these levels with a common mode Voltage with respect to GND less than ±5V for the worst case condition (4.75V supply and 13V signal level).

The tolerances in the design guarantee detection of the above levels, so the actual acceptance ranges are slightly larger. If the ARINC signal is out of the actual acceptance ranges, including the nulls, the chip rejects the data.

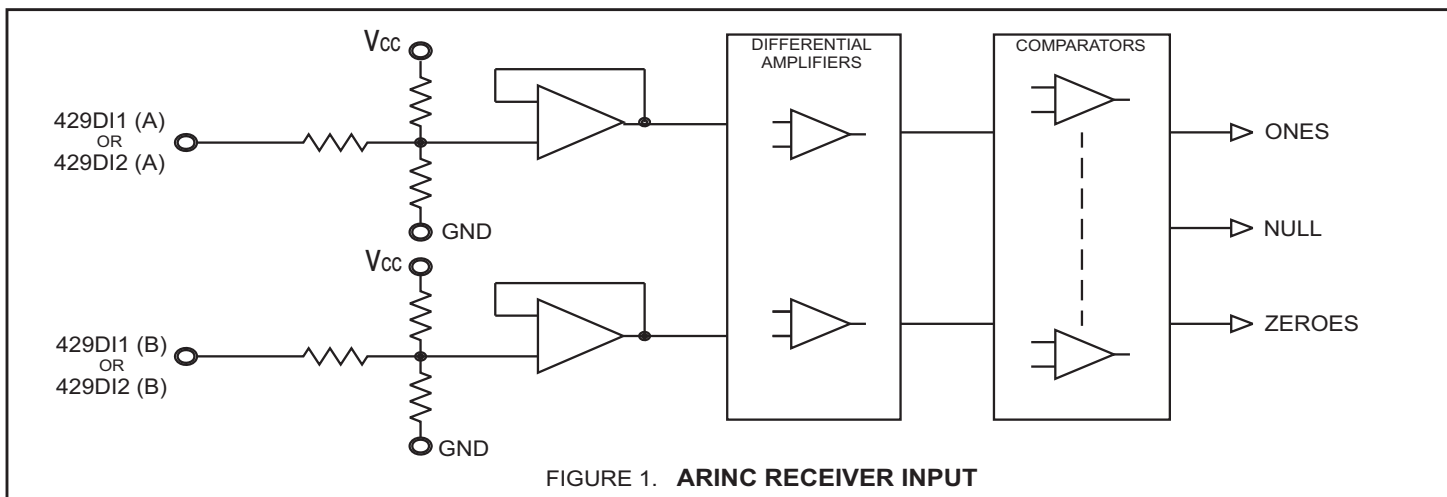

FIGURE 1. ARINC RECEIVER INPUT

FUNCTIONAL DESCRIPTION (cont.)

RECEIVER LOGIC OPERATION

Figure 2 shows a block diagram of the logic section of each receiver.

BIT TIMING

The ARINC 429 specification contains the following timing specification for the received data:

	<u>HIGH SPEED</u>	<u>LOW SPEED</u>
BIT RATE	100K BPS ± 1%	12K -14.5K BPS
PULSE RISE TIME	1.5 ± 0.5 µsec	10 ± 5 µsec
PULSE FALL TIME	1.5 ± 0.5 µsec	10 ± 5 µsec
PULSE WIDTH	5 µsec ± 5%	34.5 to 41.7 µsec

RECEIVER PARITY

The receiver parity circuit counts Ones received, including the parity bit, ARINC bit 32. If the result is odd, then "0" will appear in the 32nd bit.

RETRIEVING DATA

Once 32 valid bits are recognized, the receiver logic generates an End of Sequence (EOS). If the receiver decoder is enabled and the 9th and 10th ARINC bits match the control word program bits or if the receiver decoder is disabled, then EOS clocks the data ready flag flip flop to a "1", $\overline{D/R1}$ or $\overline{D/R2}$ (or both) will go low. The data flag for a receiver will remain low until after both ARINC bytes from that receiver are retrieved. This is accomplished by activating \overline{EN} with SEL, the byte selector, low to retrieve the first byte and activating \overline{EN} with SEL high to retrieve the second byte.

$\overline{EN1}$ retrieves data from receiver 1 and $\overline{EN2}$ retrieves data from receiver 2.

If another ARINC word is received and a new EOS occurs before the two bytes are retrieved, the data is overwritten by the new word.

INTERNAL LIGHTNING PROTECTION (-10 Only)

The HI-3282-10 configurations are similar to the HI-3282 with the exception that it allows an external 10K to 15K ohm resistor to be added in series with each ARINC input without affecting the ARINC input thresholds. This option is especially useful in applications where lightning protection circuitry is also required.

The design of the HI-3282-10 device requires the external 10K to 15K ohm series resistors for proper ARINC level detection. The typical 10 volt differential signal is translated and input to a window comparator and latch. The comparator levels are set so that, with the external 10K to 15K ohm resistors, they are just below the standard 6.5 V minimum ARINC data threshold and just above the 2.5 V maximum ARINC null threshold.

The receivers of the HI-3282-10 when used with external 15K ohm resistors will withstand DO-160F, Level 3, waveforms 3, 4, 5A and 5B. No additional lightning protection circuit is necessary.

APPLICATION NOTE 300

Please refer to the Holt AN-300 Application Note for additional information and recommendations on lightning protection of Holt Line Drivers and Receivers.

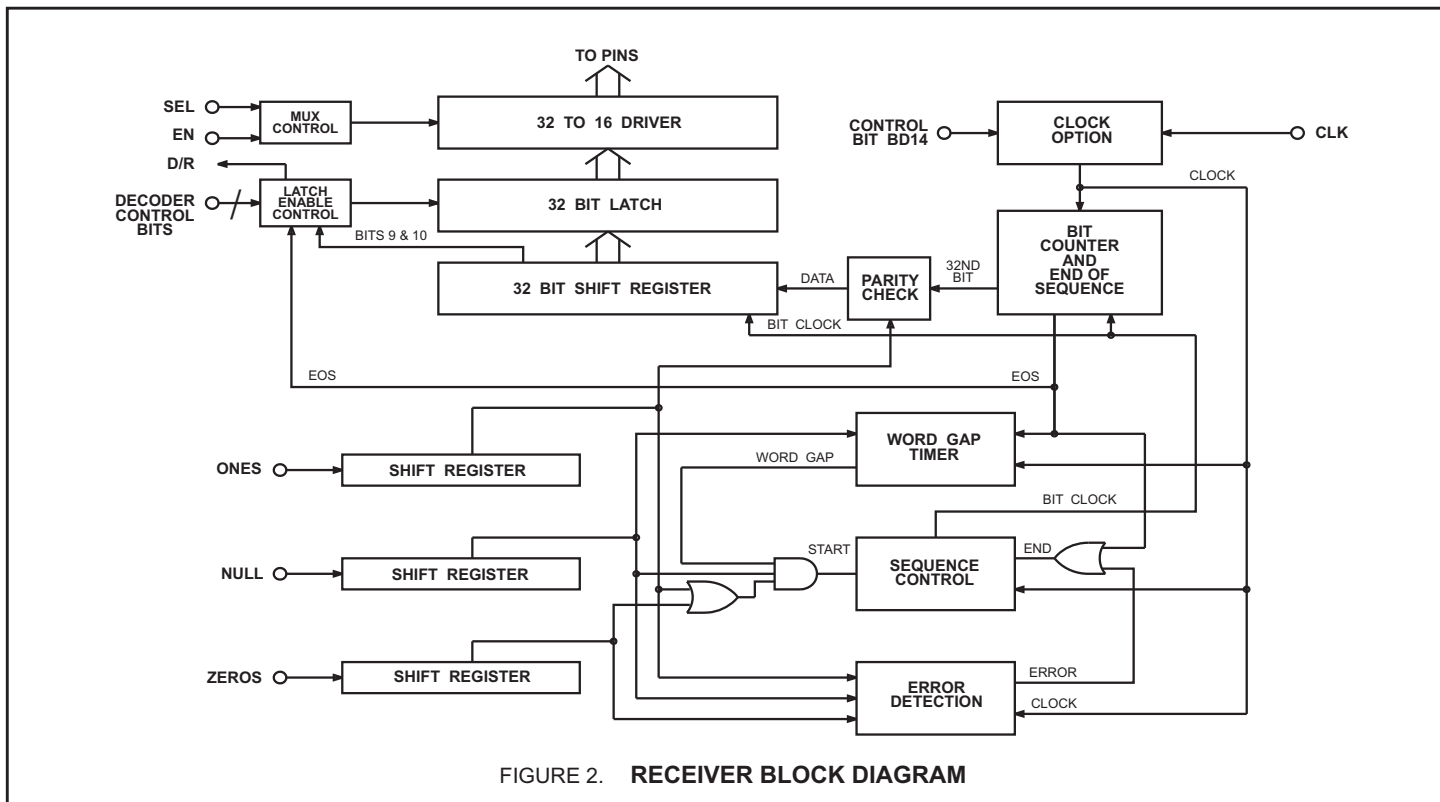

FIGURE 2. RECEIVER BLOCK DIAGRAM

FUNCTIONAL DESCRIPTION (cont.)

TRANSMITTER

A block diagram of the transmitter section is shown in Figure 3.

FIFO OPERATION

The FIFO is loaded sequentially by first pulsing $\overline{PL1}$ to load byte 1 and then $\overline{PL2}$ to load byte 2. The control logic automatically loads the 31 bit word in the next available position of the FIFO. If TX/R, the transmitter ready flag, is high (FIFO empty), then 8 words, each 31 bits long, may be loaded. If TX/R is low, then only the available positions may be loaded. If all 8 positions are full, the FIFO ignores further attempts to load data.

DATA TRANSMISSION

When ENTX goes high, enabling transmission, the FIFO positions are incremented with the top register loading into the data transmission shift register. Within 2.5 data clocks the first data bit appears at either 429DO or $\overline{429DO}$. The 31 bits in the data transmission shift register are presented sequentially to the outputs in the ARINC 429 format with the following timing:

	HIGH SPEED	LOW SPEED
ARINC DATABIT TIME	10 Clocks	80 Clocks
DATABIT TIME	5 Clocks	40 Clocks
NULL BIT TIME	5 Clocks	40 Clocks
WORD GAP TIME	40 Clocks	320 Clocks

The word counter detects when all loaded positions are transmitted and sets the transmitter ready flag, TX/R, high.

TRANSMITTER PARITY

Control register bit BD04 (PAREN) enables parity bit insertion into transmitter data bit 32. Parity is always inserted if DBCEN is open or high. If DBCEN is low, logic 0 on PAREN inserts data on bit 32, and logic 1 on PAREN inserts parity on bit 32.

The parity generator counts the ONES in the 31-bit word. If the BD12 control word bit is set low, the 32nd bit transmitted will make parity odd. If the control bit is high, the parity is even.

SELF TEST

If the BD05 control word bit is set low, $\overline{429DO}$ or $\overline{429DO}$ are internally connected to the receivers inputs, bypassing the interface circuitry. Data to Receiver 1 is as transmitted and data to Receiver 2 is the complement. $\overline{429DO}$ and $\overline{429DO}$ outputs remain active during self test.

SYSTEM OPERATION

The two receivers are independent of the transmitter. Therefore, control of data exchanges is strictly at the option of the user. The only restrictions are:

1. The received data may be overwritten if not retrieved within one ARINC word cycle.
2. The FIFO can store 8 words maximum and ignores attempts to load addition data if full.
3. Byte 1 of the transmitter data must be loaded first.
4. Either byte of the received data may be retrieved first. Both bytes must be retrieved to clear the data ready flag.
5. After ENTX, transmission enable, goes high it cannot go low until TX/R, transmitter ready flag, goes high. Otherwise, one ARINC word is lost during transmission.

MASTER RESET (\overline{MR})

On a Master Reset data transmission and reception are immediately terminated, the transmit FIFO and receivers cleared as are the transmit and receive flags. The Control Register is not affected by a Master Reset.

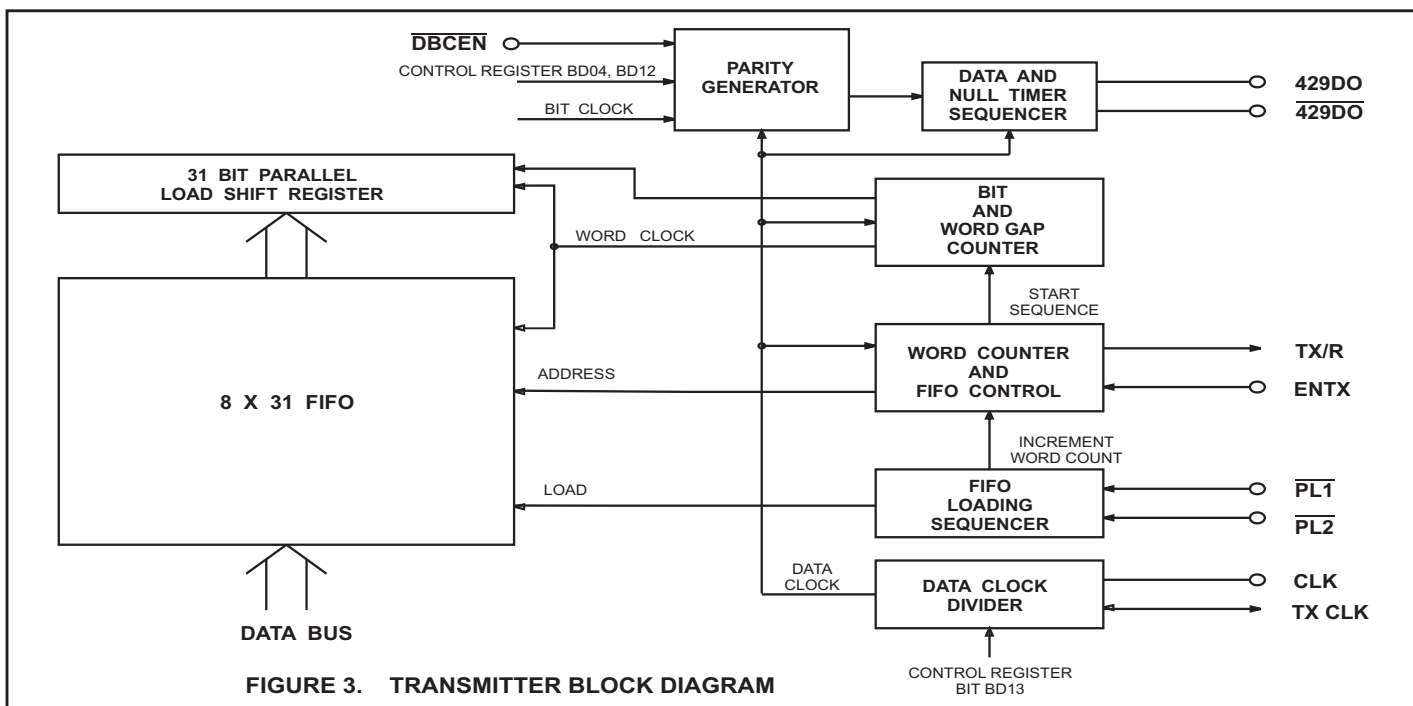

FIGURE 3. TRANSMITTER BLOCK DIAGRAM

FUNCTIONAL DESCRIPTION (cont.)

will also be placed into the transmitter FIFO. SEL is then taken high and \overline{EN} is strobed again to place the upper byte of the data word on the data bus. By strobing $\overline{PL2}$ at the same time as \overline{EN} , the second byte will also be placed into the FIFO. The data word is now ready to be transmitted according to the parity programmed into the control word register.

REPEATER OPERATION

The repeater mode of operation allows a data word that has been received by the HI-3282 to be placed directly into its FIFO for transmission. After a 32-bit word has been shifted into the receiver shift register, the $\overline{D/R}$ flag will go low. A logic "0" is placed on the SEL line and \overline{EN} is strobed. This is the same procedure as for normal receiver operation and it places the lower byte (16) of the data word on the data bus. By strobing $\overline{PL1}$ at the same time as \overline{EN} , the byte

In normal operation, either byte of a received data word may be read from the receiver latches first by use of SEL input. During repeater operation however, the lower byte of the data word must be read first. This is necessary because, as the data is being read, it is also being loaded into the FIFO and the transmitter FIFO is always loaded with the lower byte of the data word first.

TIMING DIAGRAMS

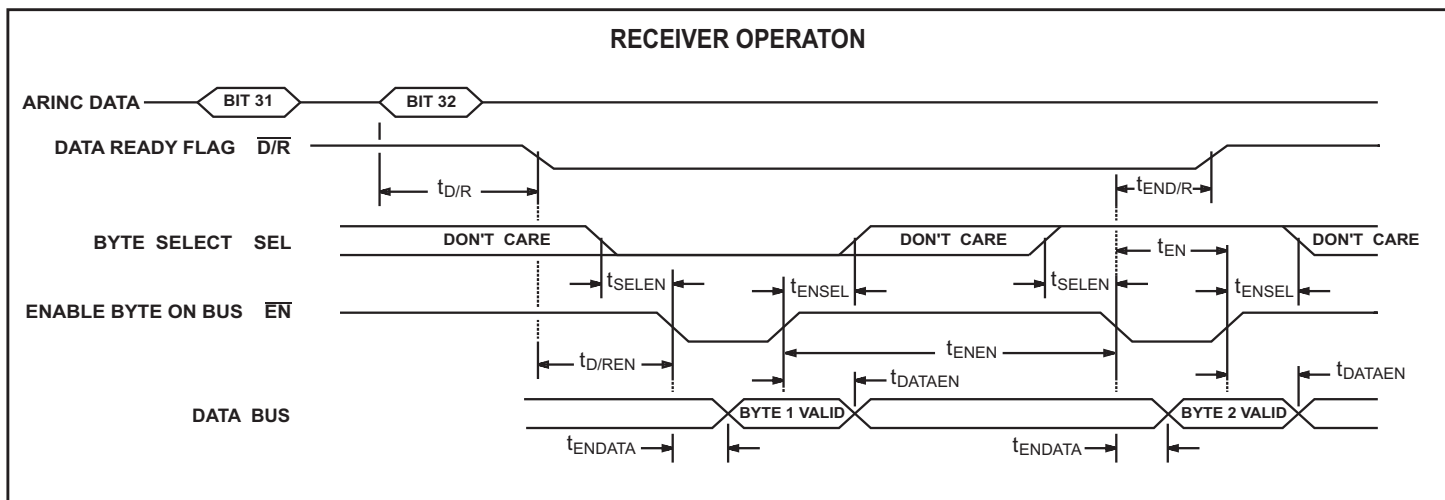
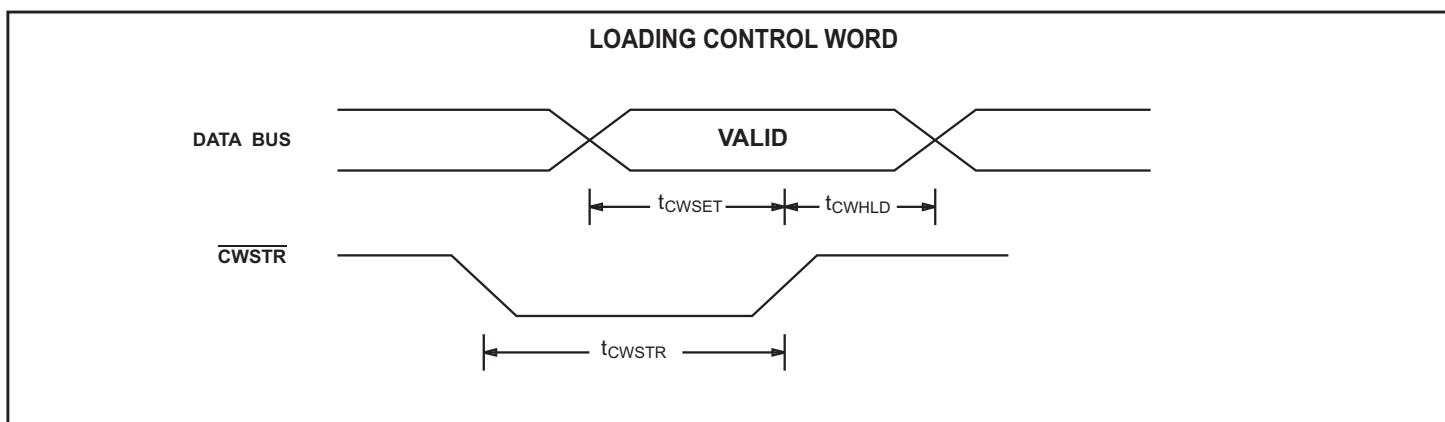
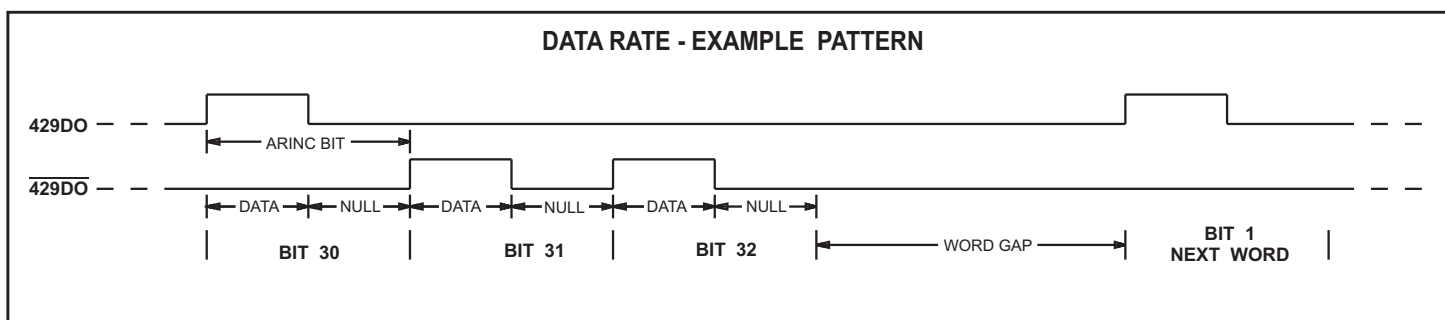

TIMING DIAGRAMS (cont.)

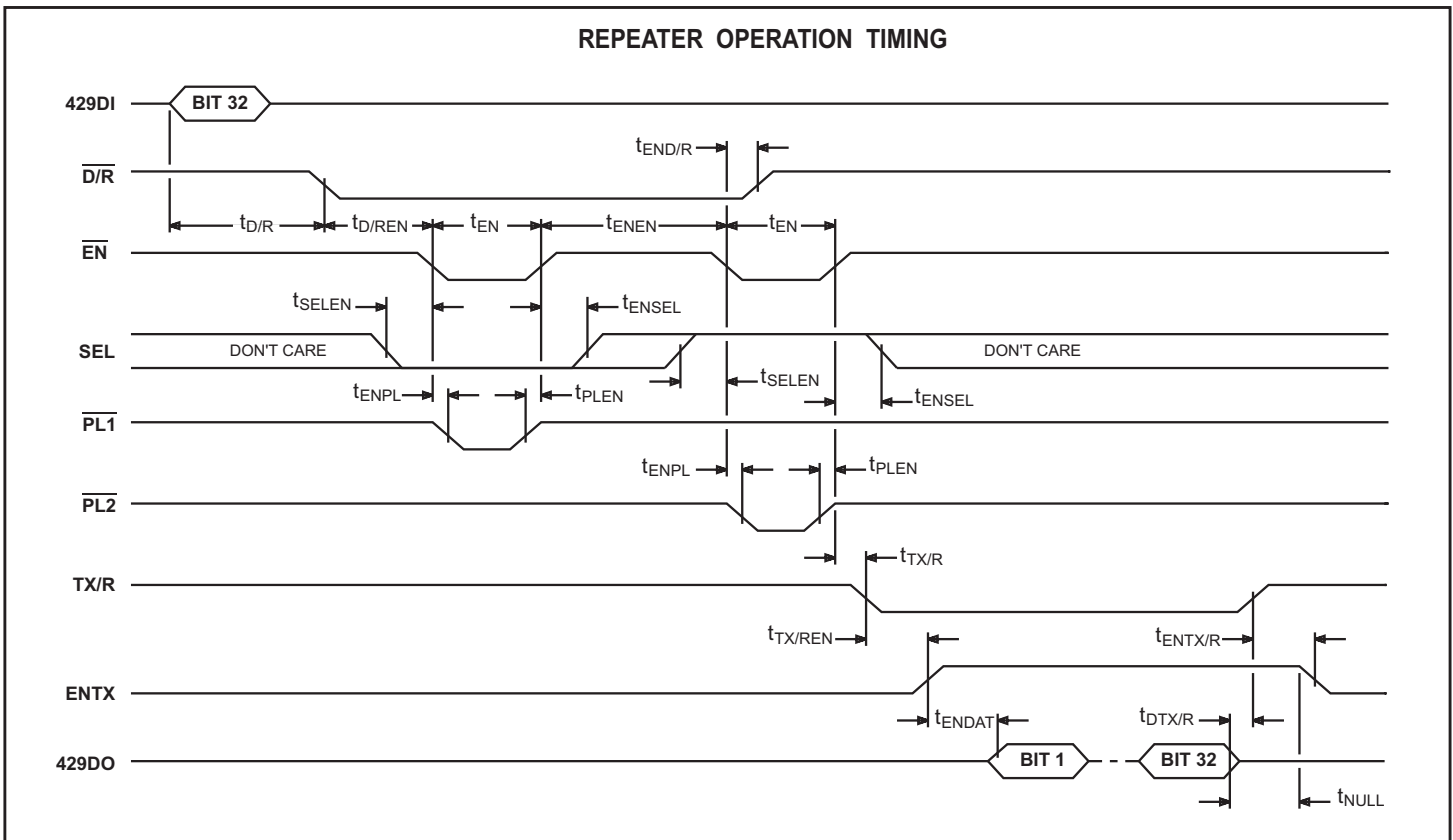
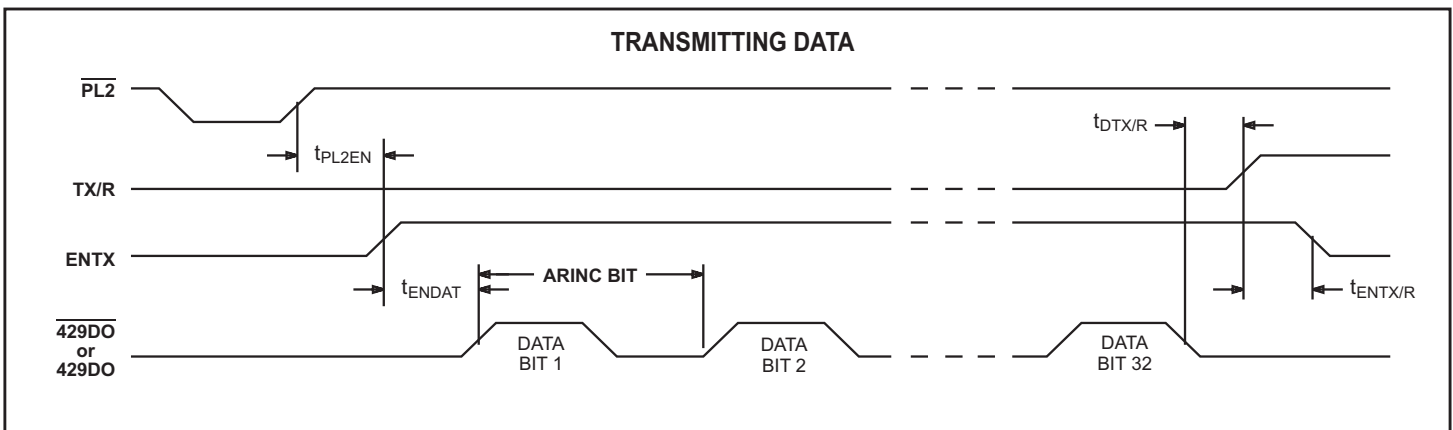
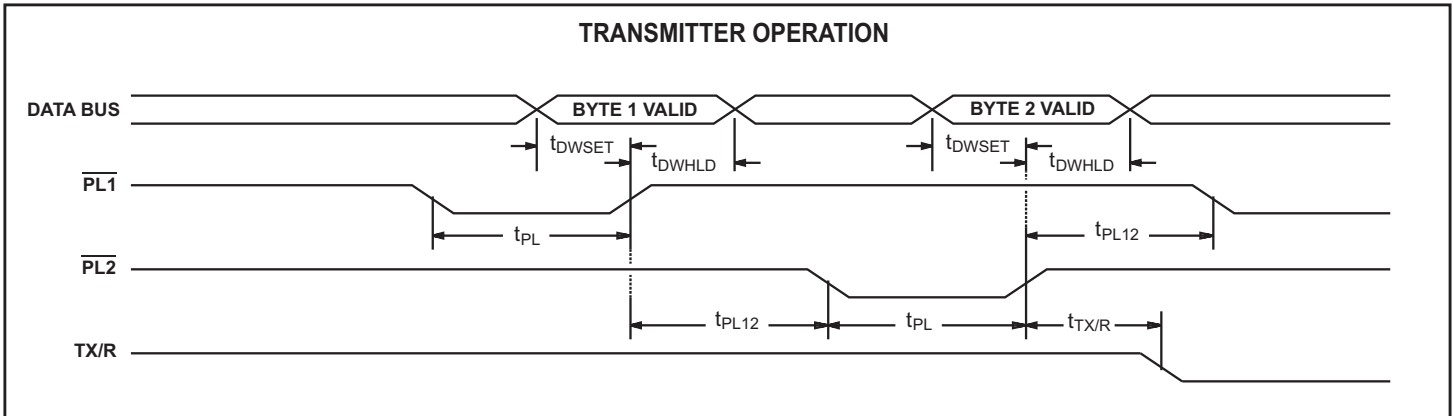

ABSOLUTE MAXIMUM RATINGS

Supply Voltage V_{cc}	-0.3V to +7V	Power Dissipation	500mW
Voltage at ARINC input pins	-29V to +29V	Operating Temperature Range: (Industrial)	-40°C to +85°C
Voltage at any other pin	-0.3V to $V_{cc} + 0.3V$		(Extended)
DC Current Drain per input pin	10mA	Storage Temperature Range:	-65°C to +150°C

NOTE: Stresses above those listed under "Absolute Maximum Ratings" may cause permanent damage to the device. These are stress ratings only. Functional operation of the device at these or any other conditions above those indicated in the operational sections of the specifications is not implied. Exposure to absolute maximum rating conditions for extended periods may affect device reliability.

DC ELECTRICAL CHARACTERISTICS

$V_{cc} = 5V \pm 5\%$, $GND = 0V$, $T_A =$ Operating Temperature Range (unless otherwise specified).

PARAMETER	SYMBOL	CONDITIONS	LIMITS			UNIT
			MIN	TYP	MAX	
ARINC INPUTS - Pins: 429DI1(A), 429DI1(B), 429DI2(A), 429DI2(B)						
Differential Input Voltage:	ONE	V_{IH}	6.5	10.0	13.0	V
	ZERO	V_{IL}	-13.0	-10.0	-6.5	V
	NULL	V_{NUL}	-2.5	0	2.5	V
Input Resistance:	Differential To GND To V_{cc}	R_I	12			K Ω
		R_G	12	27		K Ω
		R_H	12	27		K Ω
Input Current:	Input Sink Input Source	I_{IH}			200	μA
		I_{IL}	-450			μA
Input Capacitance: (Guaranteed but not tested)	Differential To GND To V_{cc}	C_I			20	pF
		C_G			20	pF
		C_H			20	pF
BI-DIRECTIONAL INPUTS - Pins:BD00-BD15						
Input Voltage:	Input Voltage HI Input Voltage LO	V_{IH}	2.0			V
		V_{IL}			0.8	V
Input Current:	Input Sink Input Source	I_{IH}			1.5	μA
		I_{IL}	-1.5			μA
ALL OTHER INPUTS						
Input Voltage:	Input Voltage HI Input Voltage LO	V_{IH}	2.0			V
		V_{IL}			0.8	V
Input Current:	Input Sink Input Source Pull-up Current (DCBEN Pin)	I_{IH}			10	μA
		I_{IL}	-10			μA
		I_{PU}	-150		-50	μA
OUTPUTS						
Output Voltage:	Logic "1" Output Voltage Logic "0" Output Voltage	V_{OH}	$I_{OH} = -1.5mA$	2.7		V
		V_{OL}	$I_{OL} = 1.6mA$		0.4	V
Output Current: (Bi-directional Pins)	Output Sink Output Source	I_{OL}	$V_{OUT} = 0.4V$	1.6		mA
		I_{OH}	$V_{OUT} = V_{cc} - 0.4V$		-1.0	mA
Output Current: (All Other Outputs)	Output Sink Output Source	I_{OL}	$V_{OUT} = 0.4V$	1.6		mA
		I_{OH}	$V_{OUT} = V_{cc} - 0.4V$		-1.0	mA
Output Capacitance:		C_o			15	pF
SUPPLY INPUT						
Standby Supply Current:		I_{CC1}			10	mA
Operating Supply Current:		I_{CC2}			10	mA

AC ELECTRICAL CHARACTERISTICS

Vcc = 5V, GND = 0V, TA = Operating Temperature Range and fclk = 1mhz ±0.1% with 60/40 duty cycle

PARAMETER	SYMBOL	LIMITS			UNITS
		MIN	TYP	MAX	
CONTROL WORD TIMING					
Pulse Width - \overline{CWSTR}	tCWSTR	50			ns
Setup - DATA BUS Valid to \overline{CWSTR} HIGH	tCWSET	50			ns
Hold - \overline{CWSTR} HIGH to DATA BUS Hi-Z	tCWHLDD	0			ns
RECEIVER TIMING					
Delay - Start ARINC 32nd Bit to $\overline{D/R}$ LOW: High Speed	td/R			16	µs
Delay - Start ARINC 32nd Bit to $\overline{D/R}$ LOW: Low Speed	td/R			128	µs
Delay - $\overline{D/R}$ LOW to \overline{EN} LOW	td/REN	0			ns
Delay - \overline{EN} LOW to $\overline{D/R}$ HIGH	tEND/R			200	ns
Setup - SEL to \overline{EN} LOW	tSELEN	0			ns
Hold - SEL to \overline{EN} HIGH	tENSEL	0			ns
Delay - \overline{EN} LOW to DATA BUS Valid	tENDATA		50	80	ns
Delay - \overline{EN} HIGH to DATA BUS Hi-Z	tDATAEN			30	ns
Pulse Width - $\overline{EN1}$ or $\overline{EN2}$	tEN	80			ns
Spacing - \overline{EN} HIGH to next \overline{EN} LOW	tENEN	50			ns
FIFO TIMING					
Pulse Width - $\overline{PL1}$ or $\overline{PL2}$	tPL	50			ns
Setup - DATA BUS Valid to \overline{PL} HIGH	tdWSET	50			ns
Hold - \overline{PL} HIGH to DATA BUS Hi-Z	tdWHLDD	10			ns
Spacing - $\overline{PL1}$ or $\overline{PL2}$	tPL12	0			ns
Delay - $\overline{PL2}$ HIGH to TX/R LOW	tTX/R			840	ns
TRANSMISSION TIMING					
Spacing - $\overline{PL2}$ HIGH to ENTX HIGH	tPL2EN	0			µs
Delay - ENTX HIGH to 429D0 or $\overline{429D0}$: High Speed	tENDAT			25	µs
Delay - ENTX HIGH to 429D0 or $\overline{429D0}$: Low Speed	tENDAT			200	µs
Delay - 32nd ARINC Bit to TX/R HIGH	tdTX/R			50	ns
Spacing - TX/R HIGH to ENTX LOW	tENTX/R	0			ns
REPEATER OPERATION TIMING					
Delay - \overline{EN} LOW to \overline{PL} LOW	tENPL	0			ns
Hold - \overline{PL} HIGH to \overline{EN} HIGH	tPLEN	0			ns
Delay - TX/R LOW to ENTX HIGH	tTX/REN	0			ns
Master Reset Pulse Width	tMR	50			ns
ARINC Data Rate and Bit Timing				± 1%	

ADDITIONAL HI-3282 PIN CONFIGURATIONS (See page 1 for the 44-pin Plastic QFP)

PIN CONFIGURATION (Top View)

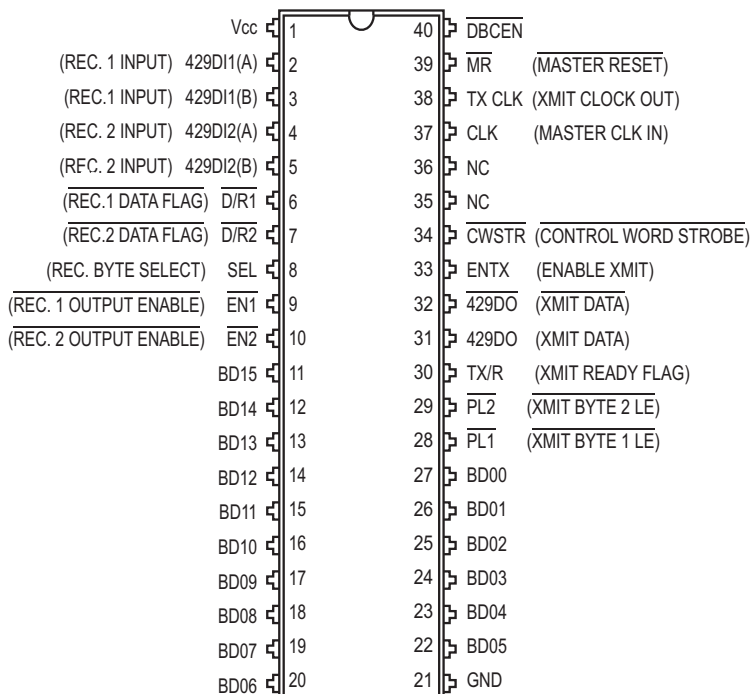

HI-3282CDI / HI-3282CDT / HI-3282CDM
HI-3282CDI-10 / HI-3282CDT-10 / HI-3282CDM-10
40-PIN CERAMIC SIDE-BRAZED DIP

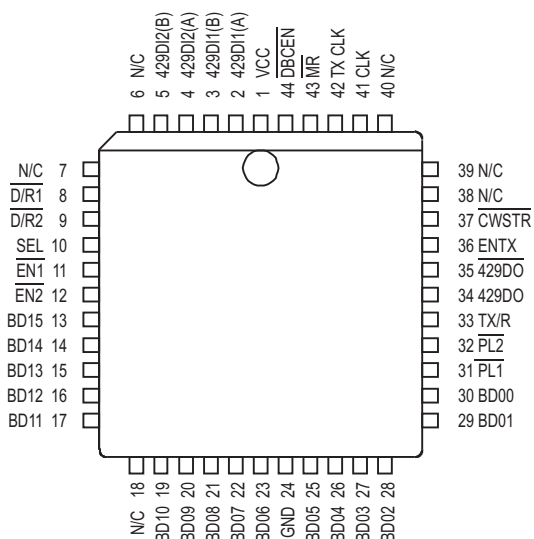

HI-3282PJI / HI-3282PJT
HI-3282PJI-10 / HI-3282PJT-10
44-Pin J-Lead PLCC

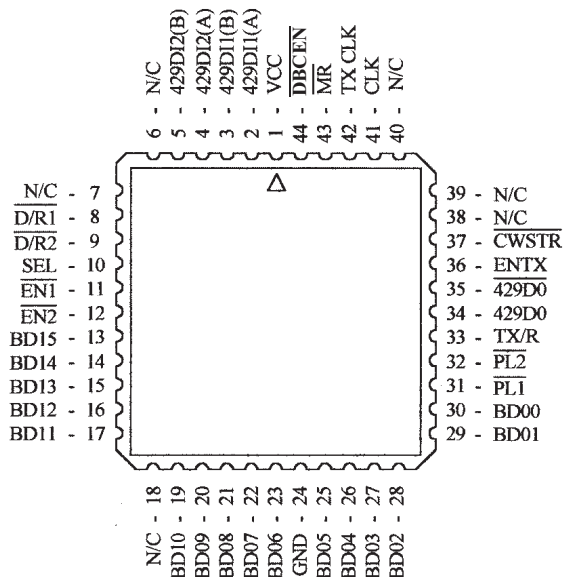

HI-3282CLI / HI-3282CT / HI-3282CLM
HI-3282CLI-10 / HI-3282CT-10 / HI-3282CLM-10
44-Pin Leadless Chip Carrier (LCC)

ORDERING INFORMATION

HI - 3282 Cx x -xx (Ceramic)

PART NUMBER	INPUT SERIES RESISTANCE	
	BUILT-IN	REQUIRED EXTERNALLY
No dash number	35K Ohm	0
-10 (See Note 1)	25K Ohm	10K to 15K Ohm

PART NUMBER	TEMPERATURE RANGE	FLOW	BURN IN	LEAD FINISH
I	-40°C TO +85°C	I	No	Gold (Pb-free, RoHS compliant)
T	-55°C TO +125°C	T	No	Gold (Pb-free, RoHS compliant)
M	-55°C TO +125°C	M	Yes	Tin / Lead (Sn / Pb) Solder

PART NUMBER	PACKAGE DESCRIPTION
CD	40 PIN CERAMIC SIDE BRAZED DIP (40C)
CL	44 PIN CERAMIC LEADLESS CHIP CARRIER (44S)

HI - 3282 Px x x -xx (Plastic)

PART NUMBER	INPUT SERIES RESISTANCE	
	BUILT-IN	REQUIRED EXTERNALLY
No dash number	35K Ohm	0
-10 (See Note 1)	25K Ohm	10K to 15K Ohm

PART NUMBER	PACKAGE DESCRIPTION
Blank	Tin / Lead (Sn / Pb) Solder
F	100% Matte Tin (Pb-free RoHS compliant)

PART NUMBER	TEMPERATURE RANGE	FLOW	BURN IN
I	-40°C TO +85°C	I	No
T	-55°C TO +125°C	T	No
M	-55°C TO +125°C	M	Yes

PART NUMBER	PACKAGE DESCRIPTION
PJ	44 PIN PLASTIC J-LEAD PLCC (44J)
PQ	44 PIN PLASTIC QUAD FLAT PACK (44PQS)

NOTES:

1. The -10 configuration requires an external 10K to 15K ohm resistor in series with each ARINC input to guarantee specified voltage thresholds. The 15K ohm resistors are required to withstand DO-160F, Level 3, Waveforms 3, 4, 5A & 5B pin injection.

REVISION HISTORY

Revision	Date	Description of Change
DS3282, Rev. L	02/24/09	Clarified the temperature ranges, series resistance values for "-10" devices, and Note (1) in the Ordering Information.

40-PIN CERAMIC SIDE-BRAZED DIP

inches (millimeters)

Package Type: 40C

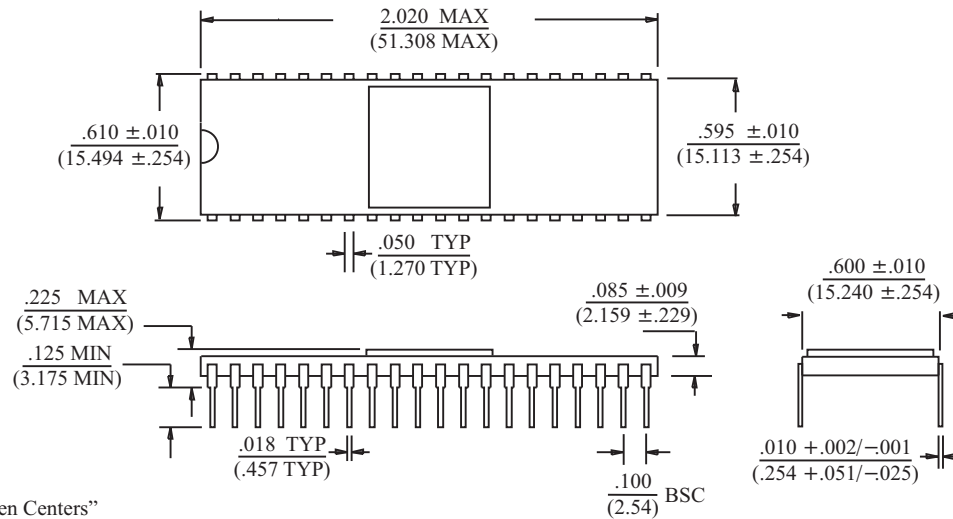

BSC = "Basic Spacing between Centers" is theoretical true position dimension and has no tolerance. (JEDEC Standard 95)

44-PIN PLASTIC PLCC

inches (millimeters)

Package Type: 44J

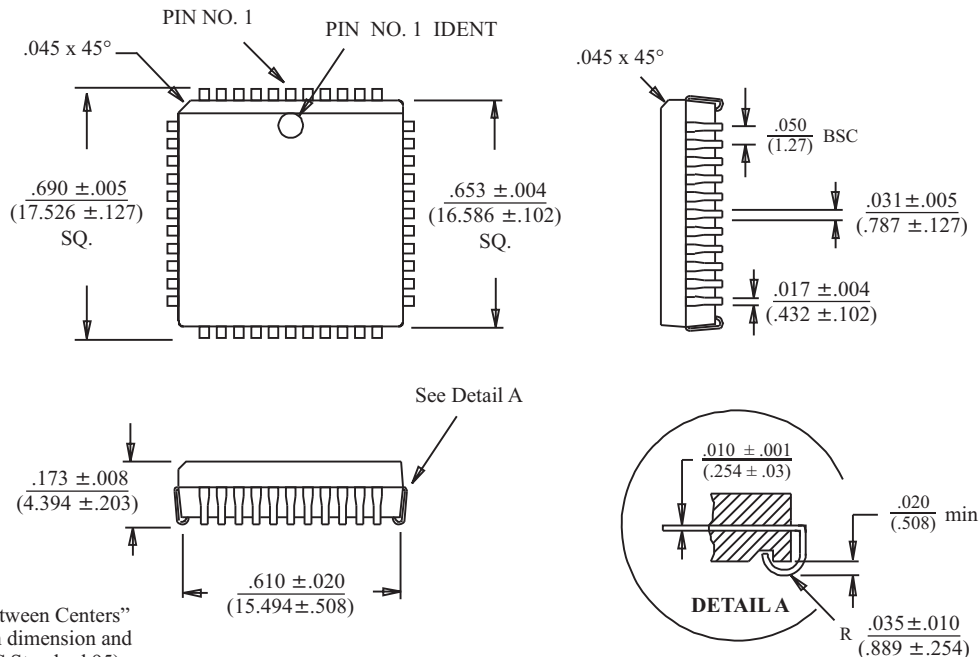

BSC = "Basic Spacing between Centers" is theoretical true position dimension and has no tolerance. (JEDEC Standard 95)

44-PIN PLASTIC QUAD FLAT PACK (PQFP)

inches (millimeters)

Package Type: 44PTQS

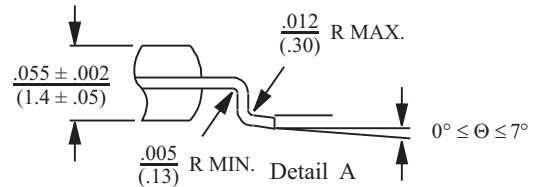
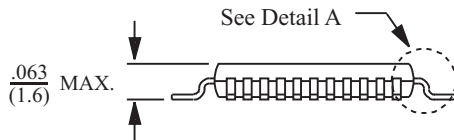
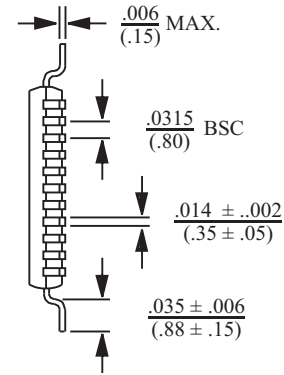
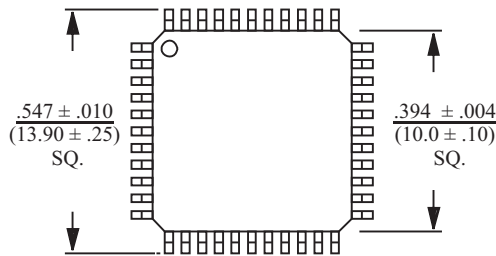

BSC = "Basic Spacing between Centers" is theoretical true position dimension and has no tolerance. (JEDEC Standard 95)

44-PIN CERAMIC LEADLESS CHIP CARRIER

inches (millimeters)

Package Type: 44S

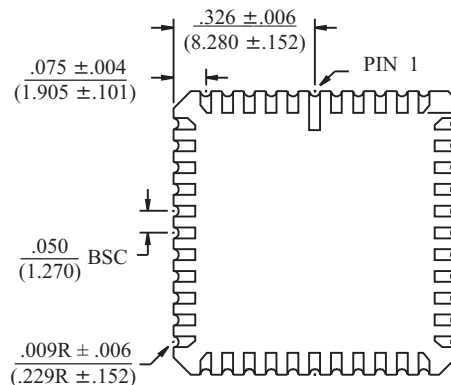
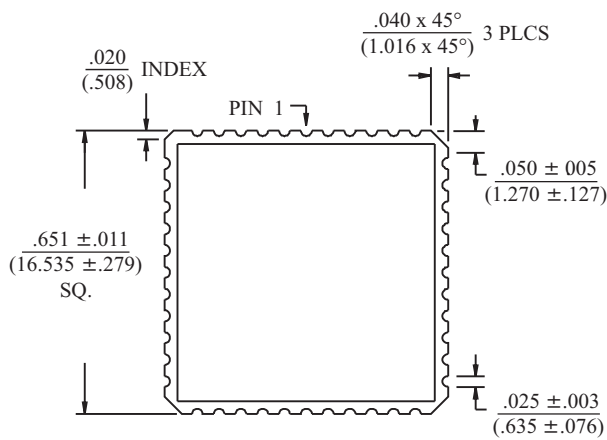

BSC = "Basic Spacing between Centers" is theoretical true position dimension and has no tolerance. (JEDEC Standard 95)