

HONEYWELL

See full Datasheet below...

onlinecomponents.com
THE ONLINE DISTRIBUTOR OF ELECTRONIC COMPONENTS

BUY NOW

 **MASTER**TM
ELECTRONICS

BUY NOW

masterelectronics.com & onlinecomponents.com
are **authorized** e-commerce distributors
of electronic components.

Fiber Optic LAN Components

660nm LED

For Industrial Bus Systems

HFX6015-xxx

FEATURES

- Super bright LED for optical fiber communication
- High accuracy by use of special plastic package with centered LED chip
- High output at suitable peak wavelength (typ.) for plastic fiber
- High frequency cut-off, most suited for high speed data transmissions ($f_c = \text{typ. } 7 \text{ MHz}$)

HFX6015-200 only

- Metal barrel for high mechanical stability
- Separate grounding of barrel for optimum EMI/RFI shielding

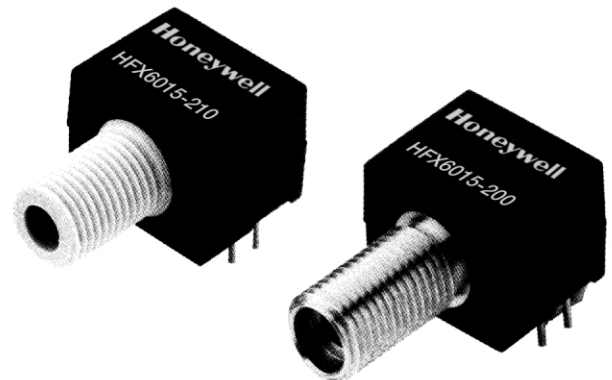

HFX6015-210

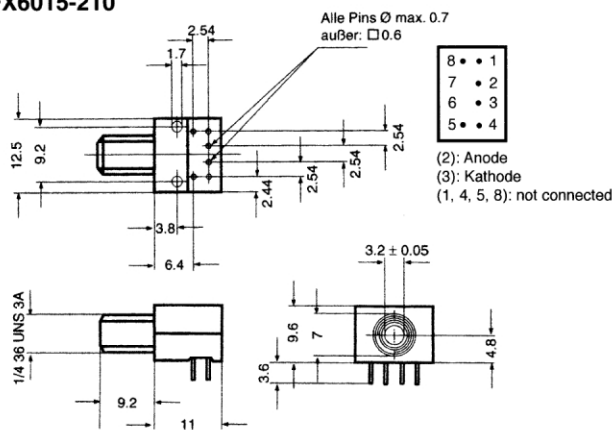

Fig. 1

HFX6015-200

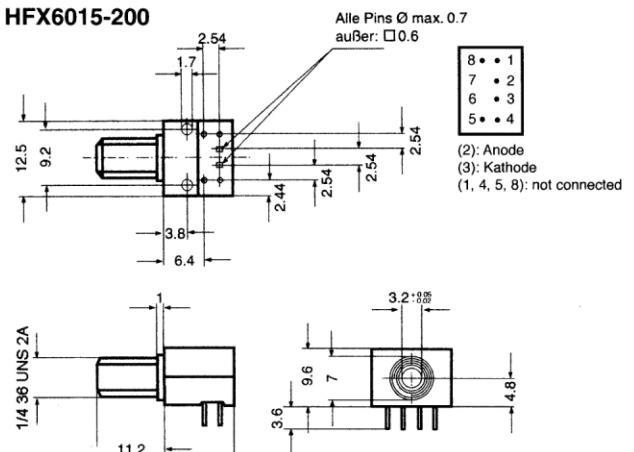

Fig. 2

SERCOS HFX6015-210 (Fig.1) and HFX6015-200 (Fig.2)

Parameter	Test Conditions	Symbol	Min	Typ	Max	Units
Coupled Power	$I_F = 50\text{mA}^*$, 1mm fibre	P_C	700		1400	μW

Note: Available for all products with date code 03.05 or later

PROFIBUS HFX6015-4xx

Parameter	Test Conditions	Symbol	Min	Typ	Max	Units
Coupled Power	1mm fibre	P_C	-5.5			dbm

GENERAL PURPOSE BUS APPLICATIONS

Parameter	Test Conditions	Symbol	Min	Typ	Max	Units
Coupled Power	$I_F = 50\text{mA}^*$, 1mm fibre	P_C	300			μW

Note: * Derate Linearly from 25°C: 0.93mA/°C DC current

Other receptacles available. For additional information see please "Mounted LEDs/Transmitters"

Fiber Optic LAN Components

660nm LED

For Industrial Bus Systems

HFX6015-xxx

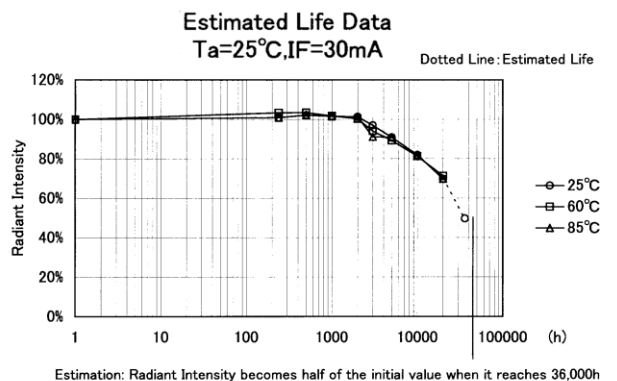
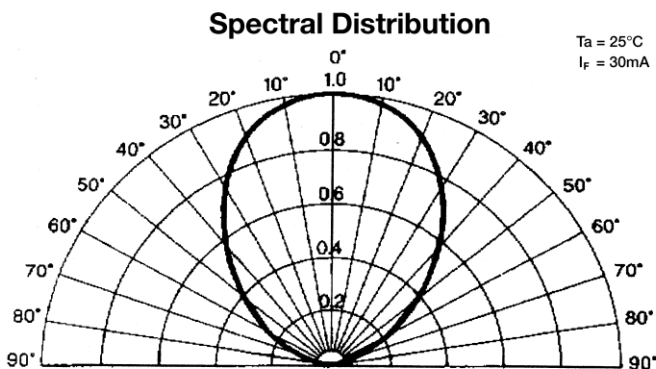
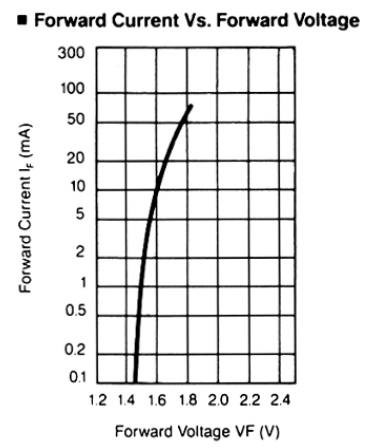
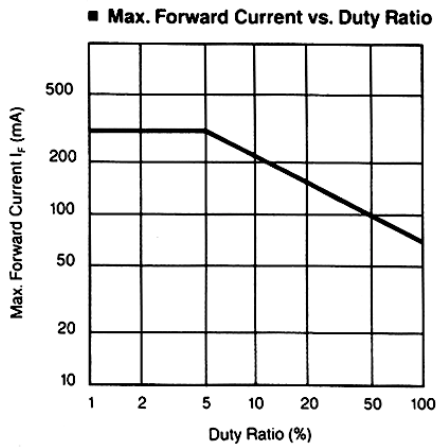
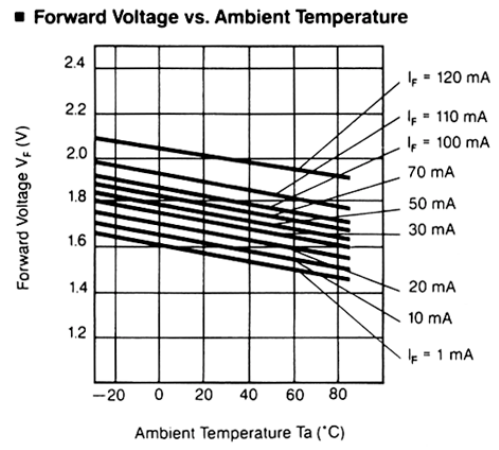
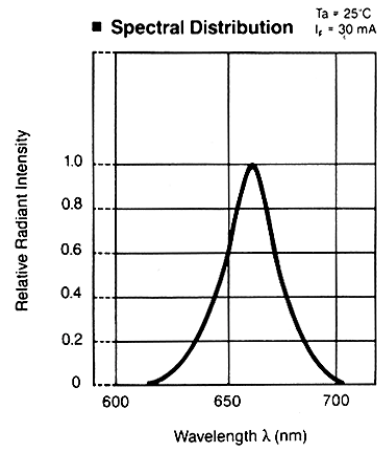
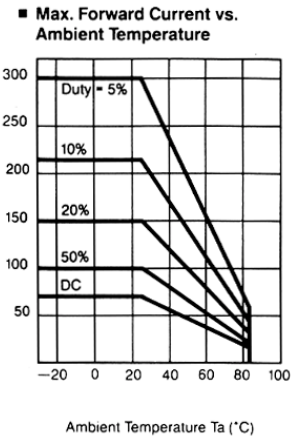
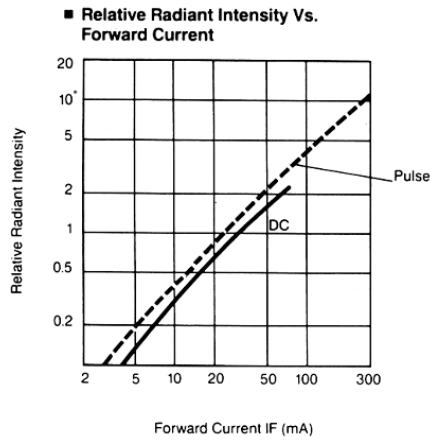

Fiber Optic LAN Components

660nm LED

For Industrial Bus Systems

HFX6015-xxx

ABSOLUTE MAXIMUM RATINGS

(25° C free air temperature unless otherwise noted)

Forward current.....70mA
Peak forward current.....(1ms pulse, 1/20 duty) 300mA
Reverse voltage.....+4V
Power dissipation.....140mW
Operating temperature.....-30°C to +85°C
Storage temperature..... -30°C to +100°C
Lead soldering time at 260°C.....5 sec (3,0mm from body)

ELECTRO OPTICAL CHARACTERISTICS

Parameter	Test Conditions	Symbol	Min	Typ	Max	Units
Peak Wavelength	$I_F = 30\text{mA}^*$	λ_P		660		nm
Spectral Line Half Width	$I_F = 30\text{mA}^*$	$\Delta\lambda$		30		nm
Forward Voltage	$I_F = 30\text{mA}^*$	V_F		2.0	2.5	V
Reverse Current	$V_R = 4\text{V}$	I_R			100	μA
Capacitance		C_o		50		pF
Response Time	$I_F = 30\text{mA}^*$	t_r, t_f		50		ns

Note: * Derate Linearly from 25°C: 0.93mA/°C DC current

WARRANTY/REMEDY

Honeywell warrants goods of its manufacture as being free of defective material and faulty workmanship. Contact your local sales office for warranty information. If warranted goods are returned to Honeywell during that period of coverage, Honeywell will repair or replace without charge those items it finds defective.

The foregoing is Buyer's sole remedy and is in lieu of all other warranties, expressed or implied, including those of merchantability and fitness for a particular purpose.

While we provide application assistance, personally, through our literature and the Honeywell web site, it is up to the customer to determine the suitability of the product in the application.

Specifications may change at any time without notice. The information we supply is believed to be accurate and reliable as of this printing. However, we assume no responsibility for its use.

SALES AND SERVICE

Honeywell serves its customers through a world-wide network of sales offices and distributors.

For application assistance, current specifications, pricing or name of the nearest Authorized Distributor, contact a nearby sales office or call:

TELEPHONE

Germany + 49-89-35 81 33 10
UK + 44-1698-481 481
USA & Canada 1-800-367-6945
International 1-815-235-6847

INTERNET

<http://www.honeywell.com/sensing/>
e-mail: info.sc@honeywell.com

© Honeywell 2005. All rights reserved.

Honeywell

Sensing and Control

Honeywell GmbH
Stuttgarter Straße 5
D-80807 Munich
Germany

www.honeywell.com/sensing