

HFCT-5911ATL

Single Mode Laser Transceivers for Gigabit Ethernet and iSCSI Applications at 1.25 Gb/s



Data Sheet



Description

The HFCT-5911ATL transceiver is a high performance, cost effective module for serial optical data communications applications operating at 1.25 Gb/s. This module is designed for single mode fiber and operates at a nominal wavelength of 1310 nm. It incorporates high performance, reliable, long wavelength optical devices and proven circuit technology to give long life and consistent service.

The transmitter section incorporates a 1310 nm Fabry Perot (FP) laser. The transmitter has full IEC 825 and CDRH Class 1 eye safety.

The receiver section uses an MOVPE grown planar SEDET PIN photo detector for low dark current and excellent responsivity.

The transceiver is supplied in the industry standard 2 x 5 DIP style package with the LC fiber connector interface and is footprint compatible with SFF Multi Source Agreement (MSA).

Features

- 10 km Links with 9/125 μm single mode fiber (SMF)
- 550 m Links in 62.5/125 μm multi mode fiber (MMF)
- Compliant to IEEE 802.3, 2000 Edition
- Compliant to Small Form Factor MSA specifications
- 2 x 5 package style with LC receptacle
- Single +3.3 V power supply
- Case operating temperature range: -10°C to $+85^{\circ}\text{C}$
- Manufactured in an ISO9002 certified facility
- Fully Class 1 CDRH/IEC 825 compliant
- Wave solder and aqueous wash process compatible

Applications

- Gigabit Ethernet 1000BASE-LX
- High speed links for Gigabit Ethernet
- Switches
- Routers
- Hubs

Functional Description

Receiver Section

Design

The receiver section for the HFCT-5911ATL contains an InGaAs/InP photo detector and a pre-amplifier mounted in an optical subassembly. This optical subassembly is coupled to a post-amplifier/decision circuit on a circuit board. The design of the optical assembly is such that it provides better than 12 dB Optical Return Loss (ORL).

The post-amplifier is ac coupled to the pre-amplifier as illustrated in Figure 1. The coupling capacitors are capable of passing the Gigabit Ethernet test pattern at 1.25 Gb/s without any significant distortion or performance penalty. If a lower signal rate, or a code which has significantly more low frequency content is used, sensitivity, jitter and pulse distortion could be degraded.

Figure 1 also shows a filter function which limits the bandwidth of the pre-amplifier output signal. The filter is designed to bandlimit the pre-amplifier output noise and thus improve the receiver sensitivity.

These components will reduce the sensitivity of the receiver as the signal bit rate is increased above 1.25 Gb/s.

Noise Immunity

The receiver includes internal circuit components to filter power supply noise. However under some conditions of EMI and power supply noise, external power supply filtering may be necessary (see Application Section).

The Signal Detect Circuit

The signal detect circuit works by sensing the peak level of the received signal and comparing this level to a reference. The SD output is low voltage TTL.

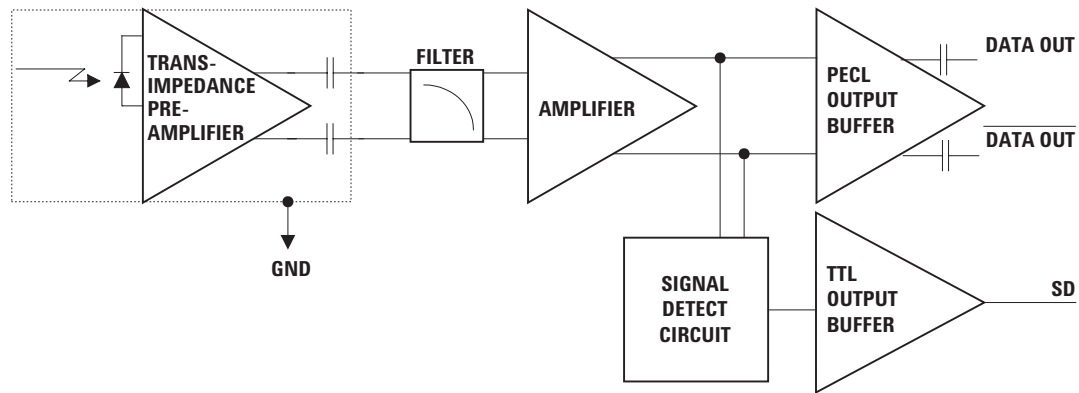

Figure 1. Receiver Block Diagram

Functional Description

Transmitter Section

Design

A schematic diagram for the transmitter is shown in Figure 2. The HFCT-5911ATL incorporates an FP laser and has been designed to be compliant with IEC 825 eye safety requirements under any single fault condition and CDRH under normal operating conditions. The optical output is controlled by a custom IC that detects the laser output via the monitor photodiode. This IC provides both dc and ac current drive to the laser to ensure correct modulation, eye diagram and extinction ratio over temperature, supply voltage and operating life.

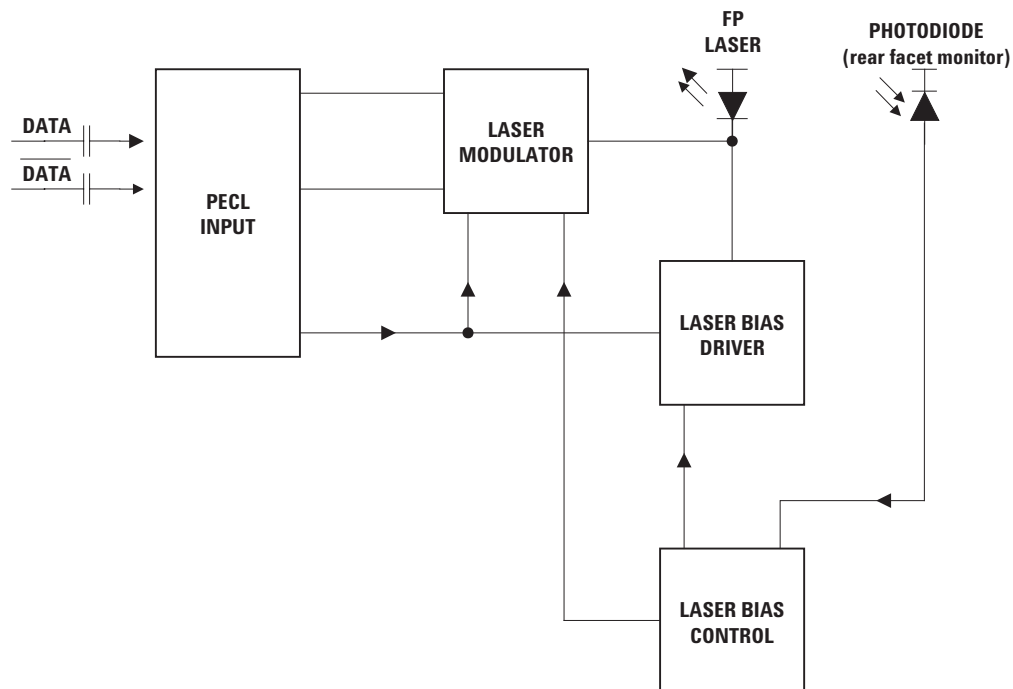

Figure 2. Simplified Transmitter Schematic

Package

The overall package concept for the device consists of the following basic elements; two optical subassemblies, two electrical subassemblies and the housing as illustrated in the block diagram in Figure 3.

The package outline drawing and pin out are shown in Figures 4 and 5. The details of this package outline and pin out are compliant with the multisource definition of the 2 x 5 DIP.

The electrical subassemblies consist of high volume multilayer printed circuit boards on which the IC and various surface-mounted passive circuit elements are attached.

The receiver electrical subassembly includes an internal shield for the electrical and optical subassembly to ensure high immunity to external EMI fields.

The optical subassemblies are each attached to their respective transmit or receive electrical subassemblies.

These two units are then placed within the outer housing of the transceiver. The outer housing of the transceiver is molded with nonconductive plastic to provide mechanical strength. The housing is then encased with a metal EMI protective shield. The case is signal ground and we recommend soldering the four ground tabs to host card signal ground.

Each electrical subassembly PCB carries the signal pins that exit from the bottom of the transceiver.

The solder posts are fastened into the molding of the device. This design provides the mechanical strength required to withstand the additional stresses on the transceiver resulting from the insertion force of fiber cable mating. Although the solder posts are connected electrically to the transceiver, it is recommended that they are connected to the chassis ground.

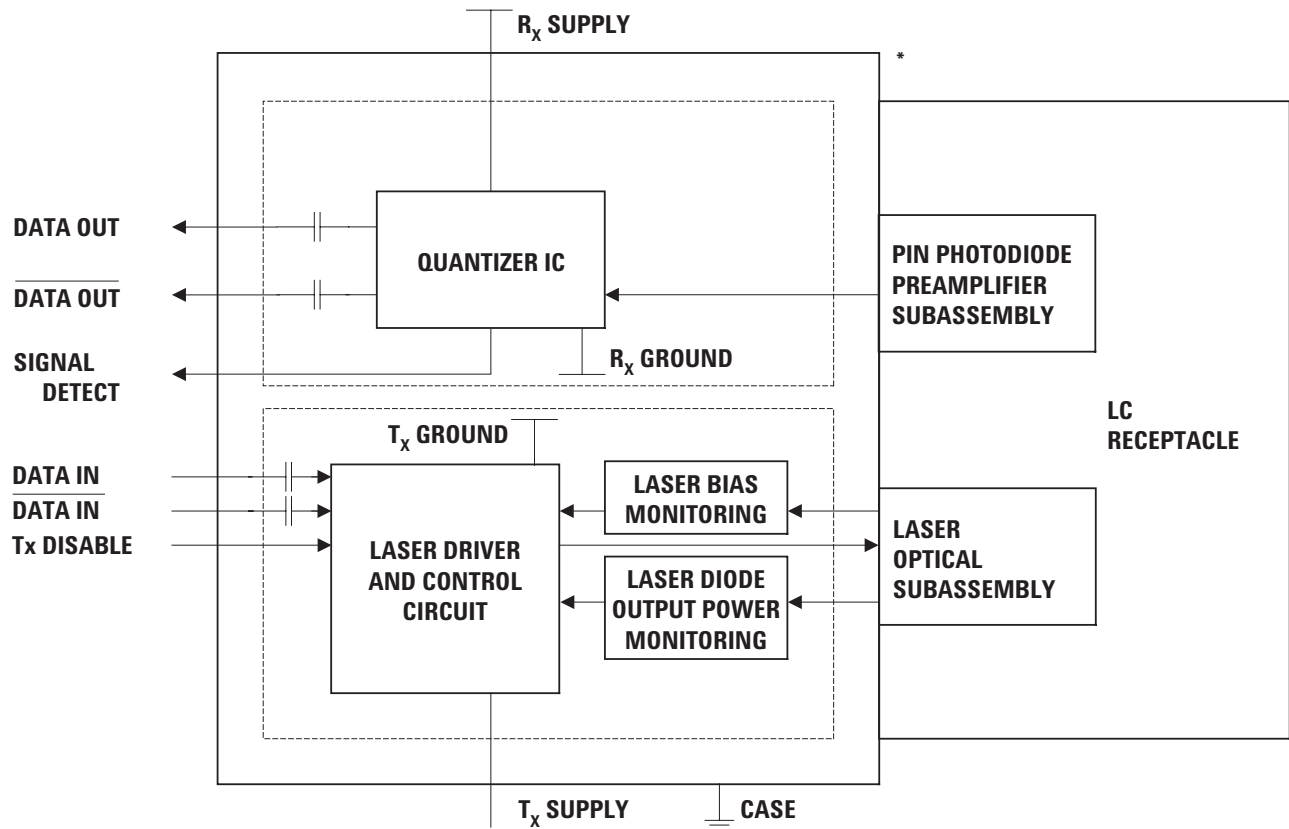

* NOSE CLIP PROVIDES CONNECTION TO CHASSIS GROUND FOR IMPROVED EMI PERFORMANCE

Figure 3. Block Diagram

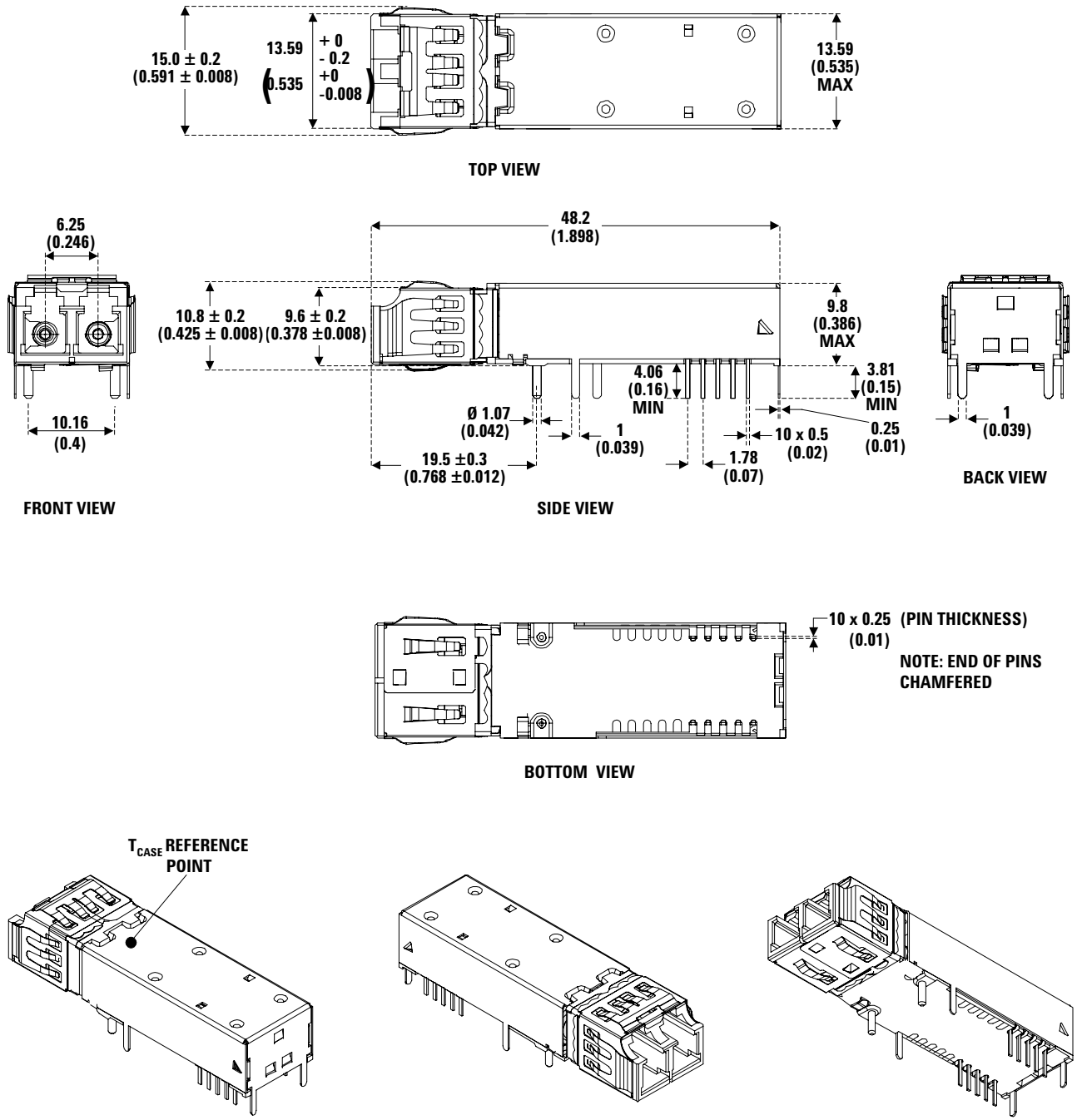

DIMENSIONS IN MILLIMETERS (INCHES)

DIMENSIONS SHOWN ARE NOMINAL. ALL DIMENSIONS MEET THE MAXIMUM PACKAGE OUTLINE DRAWING IN THE SFF MSA.

Figure 4. HFCT-5911ATL Package Outline Drawing

Connection Diagram

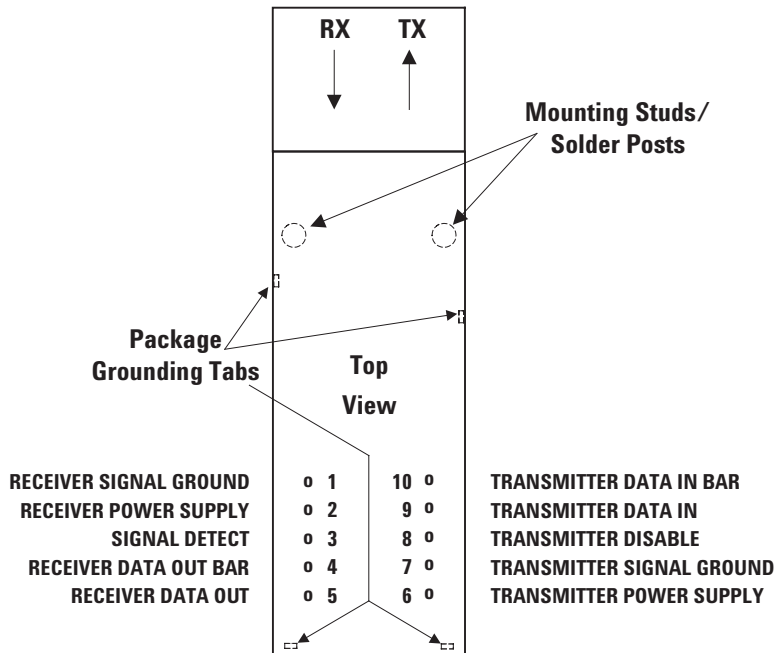

Figure 5. Pin Out Diagram (Top View)

Pin Descriptions:

Pin 1 Receiver Signal Ground V_{EE} RX:

Directly connect this pin to the receiver ground plane.

Pin 2 Receiver Power Supply V_{CC} RX:

Provide +3.3 V dc via the recommended dc receiver power supply filter circuit. Locate the power supply filter circuit as close as possible to the V_{CC} RX pin. Note: the filter circuit should not cause V_{CC} to drop below minimum specification.

Pin 3 Signal Detect SD:

Normal optical input levels to the receiver result in a logic "1" output.

Low optical input levels to the receiver result in a logic "0" output.

This Signal Detect output can be used to drive a LVTTTL input on an upstream circuit, such as Signal Detect input or Loss of Signal-bar.

Pin 4 Receiver Data Out Bar RD-:

Output internally biased and ac coupled.

Pin 5 Receiver Data Out RD+:

Output internally biased and ac coupled.

Pin 6 Transmitter Power Supply V_{CC} TX:

Provide +3.3 V dc via the recommended dc transmitter power supply filter circuit. Locate the power supply filter circuit as close as possible to the V_{CC} TX pin.

Pin 7 Transmitter Signal Ground V_{EE} TX:

Directly connect this pin to the transmitter signal ground plane.

Pin 8 Transmitter Disable T_{DIS} :

Optional feature, connect this pin to +3.3 V TTL logic high "1" to disable module. To enable module connect to TTL logic low "0".

Pin 9 Transmitter Data In TD+:

Input internally terminated and ac coupled.

Pin 10 Transmitter Data In Bar TD-:

Input internally terminated and ac coupled.

Mounting Studs/Solder Posts

The two mounting studs are provided for transceiver mechanical attachment to the circuit board. It is recommended that the holes in the circuit board be connected to chassis ground.

Package Grounding Tabs

Connect four package grounding tabs to signal ground.

Application Information

The Applications Engineering Group at Avago is available to assist you with technical understanding and design trade-offs associated with these transceivers. You can contact them through your Avago sales representative.

The following information is provided to answer some of the most common questions about the use of the parts.

Optical Power Budget and Link Penalties

The worst-case Optical Power Budget (OPB) in dB for a fiber-optic link is determined by the difference between the minimum transmitter output optical power (dBm avg) and the lowest receiver sensitivity (dBm avg). This OPB provides the necessary optical signal range to establish a working fiber-optic link. The OPB is allocated for the fiber-optic cable length and the corresponding link penalties. For proper link performance, all penalties that affect the link performance must be accounted for within the link optical power budget.

The Gigabit Ethernet IEEE 802.3 standard identifies, and has modeled, the contributions of these OPB penalties to establish the link length requirements for 62.5/125 μm and 50/125 μm multimode fiber usage. In addition, single mode fiber with standard 1310 nm Fabry-Perot lasers have been modeled and specified. Refer to the IEEE 802.3 standard and its supplemental documents that develop the model, empirical results and specifications.

Refer to Section 38.11.4 for specification of offset-launch mode-conditioning patch cord required for MMF operation of HFCT-5911ATL.

10km Link Support

As well as complying with the LX 5 km standard, the HFCT-5911ATL specification provides additional margin allowing for a 10 km Gigabit Ethernet link on a single mode fiber. This is accomplished by limiting the spectral width and center wavelength range of the transmitter while increasing the output optical power and improving sensitivity. All other LX cable plant recommendations should be followed.

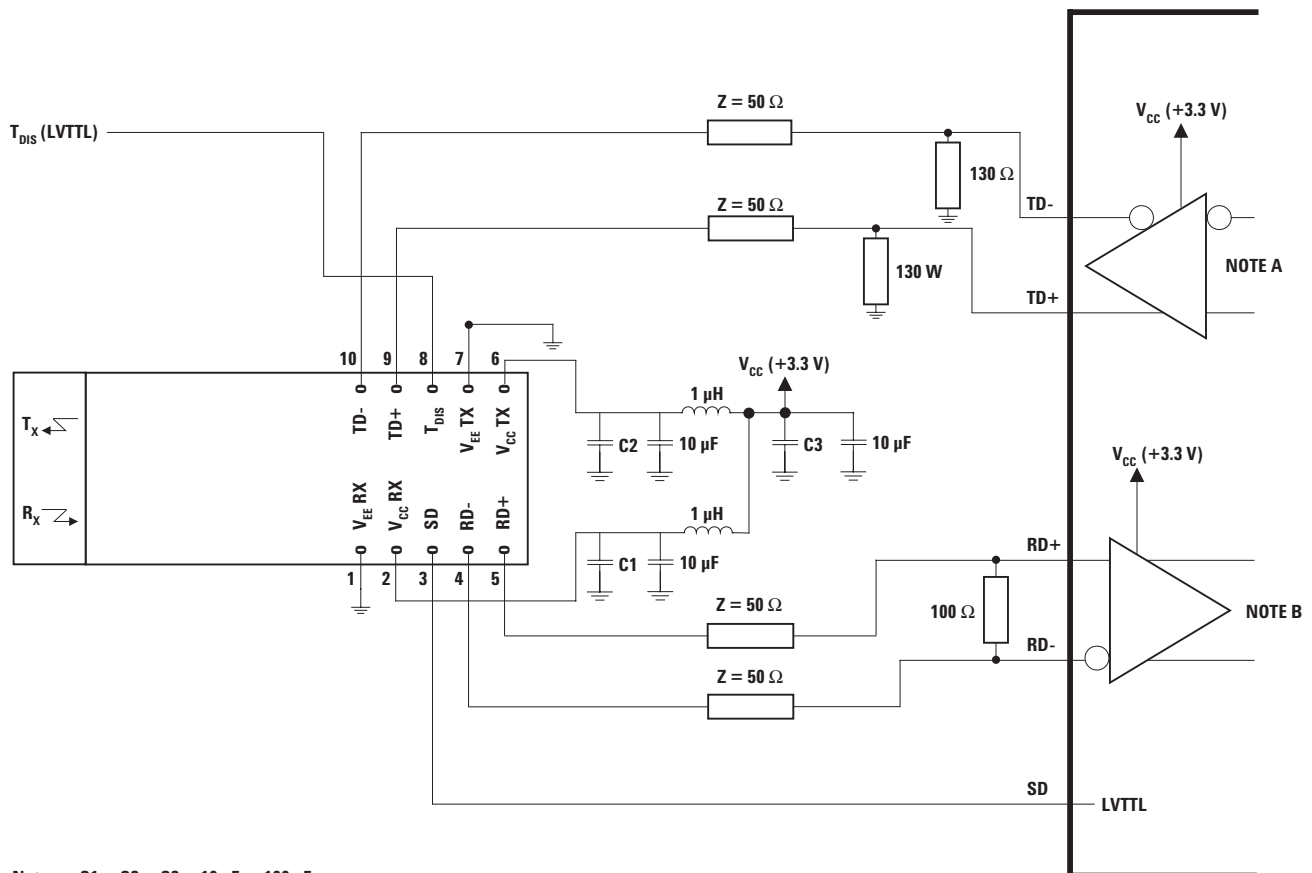

- Note:** C1 = C2 = C3 = 10 nF or 100 nF
 TD+, TD- INPUTS ARE INTERNALLY TERMINATED AND AC COUPLED.
 RD+, RD- OUTPUTS ARE INTERNALLY BIASED AND AC COUPLED.
- Note A:** CIRCUIT ASSUMES OPEN EMITTER OUTPUT.
- Note B:** CIRCUIT ASSUMES HIGH IMPEDANCE INTERNAL BIAS @ $V_{CC} - 1.3\text{ V}$.

Figure 6. Recommended Interface Circuit

Electrical and Mechanical Interface

Recommended Circuit

Figure 6 shows the recommended interface for deploying the Avago transceivers in a +3.3 V system.

Data Line Interconnections

Avago's HFCT-5911ATL fiber-optic transceivers are designed to couple to +3.3 V PECL signals. The transmitter driver circuit regulates the output optical power. The regulated light output will maintain a constant output optical power provided the data pattern is balanced in duty cycle. If the data duty cycle has long, continuous state times (low or high data duty cycle), then the output optical power will gradually change its average output optical power level to its preset value.

The HFCT-5911ATL has a transmit disable function which is a single-ended +3.3 V TTL input which is dc-coupled to Pin 8.

The receiver section is internally ac-coupled between the preamplifier and the post-amplifier stages. The Data and Data-bar outputs of the post-amplifier are internally biased and ac-coupled to their respective output pins (Pins 4, 5).

Signal Detect is a single-ended, +3.3 V TTL compatible output signal that is dc-coupled to Pin 3 of the module. Signal Detect should not be ac-coupled externally to the follow-on circuits because of its infrequent state changes.

Caution should be taken to account for the proper interconnection between the supporting Physical Layer integrated circuits and these transceivers. Figure 6 illustrates a recommended interface circuit for interconnecting to a +3.3 V dc PECL fiber-optic transceiver.

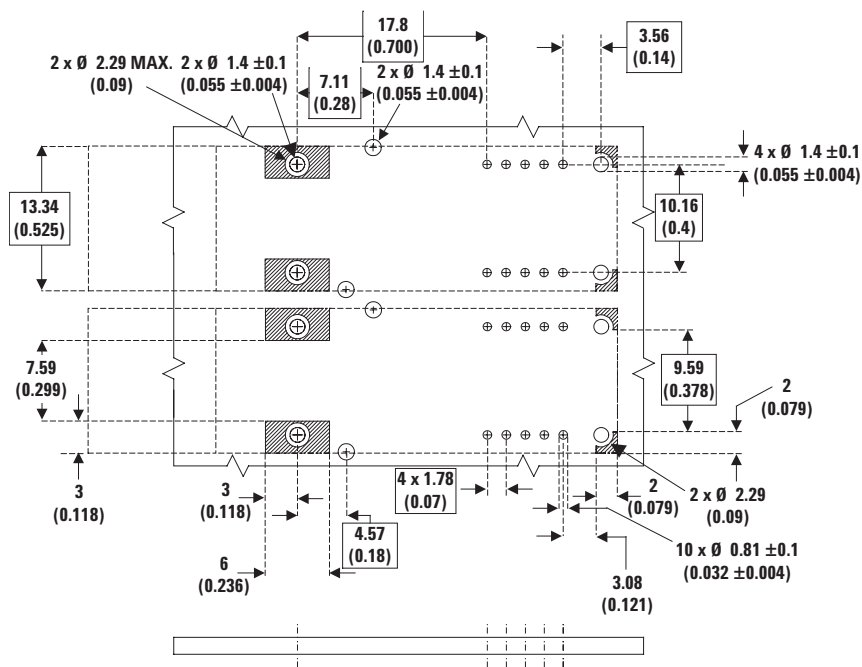

DIMENSIONS IN MILLIMETERS (INCHES)

Figure 7. Recommended Board Layout Hole Pattern

NOTES:

1. THIS FIGURE DESCRIBES THE RECOMMENDED CIRCUIT BOARD LAYOUT FOR THE SFF TRANSCEIVER.
2. THE HATCHED AREAS ARE KEEP-OUT AREAS RESERVED FOR HOUSING STANDOFFS. NO METAL TRACES OR GROUND CONNECTION IN KEEP-OUT AREAS.
3. 2 x 5 TRANSCEIVER MODULE REQUIRES 16 PCB HOLES (10 I/O PINS, 2 SOLDER POSTS AND 4 PACKAGE GROUNDING TABS). PACKAGE GROUNDING TABS SHOULD BE CONNECTED TO SIGNAL GROUND.
4. THE MOUNTING STUDS SHOULD BE SOLDERED TO CHASSIS GROUND FOR MECHANICAL INTEGRITY AND TO ENSURE FOOTPRINT COMPATIBILITY WITH OTHER SFF TRANSCEIVERS.
5. HOLES FOR HOUSING LEADS MUST BE TIED TO SIGNAL GROUND.

Power Supply Filtering and Ground Planes

It is important to exercise care in circuit board layout to achieve optimum performance from these transceivers. Figure 6 shows the power supply circuit which complies with the Small Form Factor Multisource Agreement. It is further recommended that a continuous ground plane be provided in the circuit board directly under the transceiver to provide a low inductance ground for signal return current. This recommendation is in keeping with good high frequency board layout practices.

Package footprint and front panel considerations

The Avago transceivers comply with the circuit board "Common Transceiver Footprint" hole pattern defined in the current multisource agreement which defined the 2 x 5 package style. This drawing is reproduced in Figure 7 with the addition of ANSI Y14.5M compliant dimensioning to be used as a guide in the mechanical layout of your circuit board. Figure 8 shows the front panel dimensions associated with such a layout.

Eye Safety Circuit

For an optical transmitter device to be eye-safe in the event of a single fault failure, the transmitter must either maintain eye-safe operation or be disabled.

The HFCT-5911ATL is intrinsically eye safe and does not require shut down circuitry.

Signal Detect

The Signal Detect circuit provides a de-asserted output signal when the optical link is broken (or when the remote transmitter is OFF). The Signal Detect threshold is set to transition from a high to low state between the minimum receiver input optical power and -30 dBm avg. input optical power indicating a definite optical fault (e.g. unplugged connector for the receiver or transmitter, broken fiber, or failed far-end transmitter or data source). The Signal Detect does not detect receiver data error or error-rate. Data errors can be determined by signal processing offered by upstream PHY ICs.

Electromagnetic Interference (EMI)

One of a circuit board designer's foremost concerns is the control of electromagnetic emissions from electronic equipment. Success in controlling generated Electromagnetic Interference (EMI) enables the designer to pass a governmental agency's EMI regulatory standard and more importantly, it reduces the possibility of interference to neighboring equipment. Avago has designed the HFCT-5911ATL to provide good EMI performance. The EMI performance of a chassis is dependent on physical design and features which help improve EMI suppression. Avago encourages using standard RF suppression practices and avoiding poorly EMI-sealed enclosures.

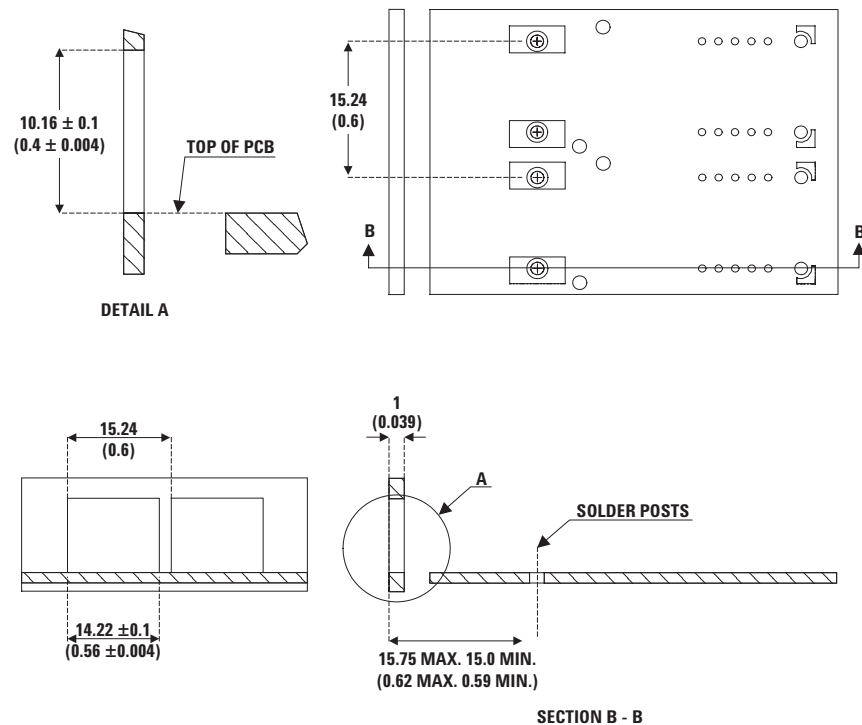

DIMENSIONS IN MILLIMETERS (INCHES)

- FIGURE DESCRIBES THE RECOMMENDED FRONT PANEL OPENING FOR A LC OR SG SFF TRANSCEIVER.
- SFF TRANSCEIVER PLACED AT 15.24 mm (0.6) MIN. SPACING.

Figure 8. Recommended Panel Mounting

Avago's LC transceivers (HFCT-5911ATL) have nose shields which provide a convenient chassis connection to the nose of the transceiver. This nose shield improves system EMI performance by effectively closing off the LC aperture. Localized shielding is also improved by tying the four metal housing package grounding tabs to signal ground on the PCB. Though not obvious by inspection, the nose shield and metal housing are electrically separated for customers who do not wish to directly tie chassis and signal grounds together. Figure 8 shows the recommended positioning of the transceivers with respect to the PCB and faceplate.

Package and Handling Instructions

Flammability

The HFCT-5911ATL transceiver housing consists of high strength, heat resistant and UL 94 V-0 flame retardant plastic and metal packaging.

Recommended Solder and Wash Process

The HFCT-5911ATL are compatible with industry-standard wave solder processes.

Process plug

This transceiver is supplied with a process plug for protection of the optical port within the LC connector receptacle. This process plug prevents contamination during wave solder and aqueous rinse as well as during handling, shipping and storage. It is made of a high-temperature, molded sealing material that can withstand +85°C and a rinse pressure of 110 lbs per square inch.

Recommended Solder fluxes

Solder fluxes used with the HFCT-5911ATL should be water-soluble, organic fluxes. Recommended solder fluxes include Lonco 3355-11 from London Chemical West, Inc. of Burbank, CA, and 100 Flux from Alpha-Metals of Jersey City, NJ.

Recommended Cleaning/Degreasing Chemicals

Alcohols: methyl, isopropyl, isobutyl.

Aliphatics: hexane, heptane

Other: naphtha.

Do not use partially halogenated hydrocarbons such as 1,1,1 trichloroethane, ketones such as MEK, acetone, chloroform, ethyl acetate, methylene dichloride, phenol, methylene chloride, or N-methylpyrrolidone. Also, Avago does not recommend the use of cleaners that use halogenated hydrocarbons because of their potential environmental harm.

LC SFF Cleaning Recommendations

In the event of contamination of the optical ports, the recommended cleaning process is the use of forced nitrogen. If contamination is thought to have remained, the optical ports can be cleaned using a NTT international Cletop stick type (diam. 1.25mm) and HFE7100 cleaning fluid.

Regulatory Compliance

The Regulatory Compliance for transceiver performance is shown in Table 1. The overall equipment design will determine the certification level. The transceiver performance is offered as a figure of merit to assist the designer in considering their use in equipment designs.

Electrostatic Discharge (ESD)

The device has been tested to comply with MIL-STD-883 (Method 3015). It is important to use normal ESD handling precautions for ESD sensitive devices. These precautions include using grounded wrist straps, work benches, and floor mats in ESD controlled areas.

Electromagnetic Interference (EMI)

Most equipment designs utilizing these high-speed transceivers from Avago will be required to meet FCC regulations in the United States, CENELEC EN55022 (CISPR 22) in Europe and VCCI in Japan. Refer to EMI section (page 9) for more details.

Immunity

Transceivers will be subject to radio-frequency electromagnetic fields following the IEC 61000-4-3 test method.

Eye Safety

These laser-based transceivers are classified as AEL Class I (U.S. 21 CFR(J) and AEL Class 1 per IEC60825-1 (+A11)). They are eye safe when used within the data sheet limits per CDRH. They are also eye safe under normal operating conditions and under all reasonably foreseeable single fault conditions per IEC60825-1. Avago has tested the transceiver design for compliance with the requirements listed below. These tests were conducted under normal operating conditions and under single fault conditions where applicable. TUV Rheinland has granted certification to these transceivers for laser eye safety and use in IEC60825-2 applications. Their performance enables the transceivers to be used without concern for eye safety up to 3.6 V transmitter V_{CC} .

Table 1: Regulatory Compliance - Targeted Specification

Feature	Test Method	Performance
Electrostatic Discharge (ESD) to the Electrical Pins	MIL-STD-883Method 3015	Class 2 (>2 kV).
Electrostatic Discharge (ESD) to the LC Receptacle	Variation of IEC 61000-4-2	Tested to 8 kV contact discharge.
Electromagnetic Interference (EMI)	FCC Class B CENELEC EN55022 Class B (CISPR 22A) VCCI Class I	Margins are dependent on customer board and chassis designs.
Immunity	Variation of IEC 61000-4-3	Typically show no measurable effect from a 10 V/m field swept from 27 to 1000 MHz applied to the transceiver without a chassis enclosure.
Laser Eye Safety and Equipment Type Testing	FDA CDRH 21-CFR 1040 Class 1 IEC 60825-1Amendment 22001 - 01	Accession Number: HFCT-5911ATL) 9521220 - 53 License Number: 933/510206/01
Component Recognition	Underwriters Laboratories and Canadian Standards Association Joint Component Recognition for Information Technology Equipment Including Electrical Business Equipment.	UL File Number: E173874

CAUTION:

There are no user serviceable parts nor any maintenance required for the HFCT-5911ATL. All adjustments are made at the factory before shipment to our customers. Tampering with or modifying the performance of the parts will result in voided product warranty. It may also result in improper operation of the circuitry, and possible overstress of the laser source. Device degradation or product failure may result.

Connection of the devices to a non-approved optical source, operating above the recommended absolute maximum conditions or operating the HFCT-5911ATL in a manner inconsistent with its design and function may result in hazardous radiation exposure and may be considered an act of modifying or manufacturing a laser product. The person(s) performing such an act is required by law to re-certify and re-identify the laser product under the provisions of U.S. 21 CFR (Subchapter J).

Absolute Maximum Ratings

Stresses in excess of the absolute maximum ratings can cause catastrophic damage to the device. Limits apply to each parameter in isolation, all other parameters having values within the recommended operating conditions. It should not be assumed that limiting values of more than one parameter can be applied to the product at the same time. Exposure to the absolute maximum ratings for extended periods can adversely affect device reliability.

Parameter	Symbol	Min	Typ	Max	Unit	Notes
Storage Temperature(non-operating)	T_S	-40		+85	°C	
Relative Humidity	RH			85	%	
Supply Voltage	V_{CC}	-0.5		3.6	V	1
Input Voltage on any Pin	V_I	-0.5		V_{CC}	V	

Recommended Operating Conditions

Parameter	Symbol	Min	Typ	Max	Unit	Notes
Case Operating Temperature	T_C	-10	+25	+85	°C	
Supply Voltage	V_{CC}	3.1	3.3	3.5	V	
Power Supply Noise Rejection	PSNR	100			mV _{p-p}	2
Data Output Load	R_{DL}		50		W	
Transmit Disable Input Voltage - Low	T_{DIS}			0.6	V	
Transmit Disable Input Voltage - High	T_{DIS}	2.2			V	
Transmit Disable Assert Time	T_{ASSERT}			10	µs	3
Transmit Disable Deassert Time	$T_{DEASSERT}$			1.0	ms	4

Process Compatibility

Parameter	Symbol	Min	Typ	Max	Unit	Notes
Wave Soldering and Aqueous Wash	T_{SOLD}/t_{SOLD}			+260/10	°C/sec.	5

Notes:

1. The transceiver is class 1 eye safe up to $V_{CC} = 3.6$ V.
2. Tested with a sinusoidal signal in the frequency range from 10 Hz to 1 MHz on the V_{CC} supply with the recommended power supply filter in place. Typically less than a 1 dB change in sensitivity is experienced.
3. Time delay from Transmit Disable Assertion to laser shutdown.
4. Time delay from Transmit Disable Deassertion to laser startup.
5. Aqueous wash pressure <110 psi.

Transmitter Electrical Characteristics

$T_C = -10^{\circ}\text{C}$ to $+85^{\circ}\text{C}$, $V_{CC} = 3.1\text{ V}$ to 3.5 V

Parameter	Symbol	Min	Typ	Max	Unit	Notes
Supply Current	I_{CCT}		52	120	mA	
Transmitter Power Dissipation	P_{DIST}		172	420	mW	
Data Input Voltage Swing (single-ended)	$V_{IH} - V_{IL}$	250		930	mV	
Transmitter DifferentialData Input Current - Low	I_{IL}	-350			μA	
Transmitter DifferentialData Input Current - High	I_{IH}			350	μA	

Receiver Electrical Characteristics

$T_C = -10^{\circ}\text{C}$ to $+85^{\circ}\text{C}$, $V_{CC} = 3.1\text{ V}$ to 3.5 V

Parameter	Symbol	Min	Typ	Max	Unit	Notes
Supply Current	I_{CCRX}		103	140	mA	
Receiver Power Dissipation	P_{DISS}		340	490	mW	
Data Output Voltage Swing (single-ended)	$V_{OH} - V_{OL}$	575		930	mV	1
Data Output Rise Time	t_r			0.40	ns	2
Data Output Fall Time	t_f			0.40	ns	2
Signal Detect Output Voltage - Low	V_{OL}			0.6	V	3
Signal Detect Output Voltage - High	V_{OH}	2.0			V	3
Signal Detect Assert Time (OFF to ON)	AS_{MAX}			100	μs	
Signal Detect Deassert Time (ON to OFF)	ANS_{MAX}			100	μs	

Notes:

1. These outputs are compatible with 10 k, 10 kH, and 100 k ECL and PECL inputs.
2. These are 20-80% values.
3. SD is LVTTTL compatible.

Transmitter Optical Characteristics

$T_C = -10^\circ\text{C}$ to $+85^\circ\text{C}$, $V_{CC} = 3.1\text{ V}$ to 3.5 V

Parameter	Symbol	Min	Typ	Max	Unit	Notes
Output Optical Power						
9 μm SMF	P_{OUT}	-9.5		-3	dBm	1
62.5 μm MMF		-11.5		-3		
50 μm MMF		11.5		-3		
Optical Extinction Ratio	ER	9			dB	
Center Wavelength	Cl	1278		1343	nm	8, Fig 10
Spectral Width - RMS			1.4	2.8	nm	8, Fig 10
Optical Rise/Fall Time	$T_{RISE/FALL}$			0.26	ns	2, 3, Fig 9
Random Intensity Noise	RIN_{12}			-120	dB/Hz	
Contributed Total Jitter added at TP2	TJ			227	ps	4
Coupled Power Ratio 62.5 μm MMF	CPR			28<CPR<40		
Coupled Power Ratio 50 μm MMF	CPR			12<CPR<20		

Receiver Optical Characteristics

$T_C = -10^\circ\text{C}$ to $+85^\circ\text{C}$, $V_{CC} = 3.1\text{ V}$ to 3.5 V

Parameter	Symbol	Min	Typ	Max	Unit	Reference
Receiver Overload	$P_{IN\ MAX}$	-3			dBm avg	
Receiver Sensitivity	$P_{IN\ MIN}$			-20	dBm avg	5
Stressed Receiver Sensitivity				-14.4	dBm avg	6, 7
Stressed Receiver Eye Opening at TP4		201			ps	4, 7
Receiver Electrical 3 dB Upper Cutoff Frequency				1500	MHz	
Operating Center Wavelength	I_C	1270		1570	nm	
Return Loss		12			dB	
Signal Detect - Asserted	P_A			-20	dBm avg	
Signal Detect - Deasserted	P_D	-30			dBm avg	
Signal Detect - Hysteresis	$P_A - P_D$	1.5			dB	

Notes:

1. The maximum Optical Output Power complies with IEEE 802.3 specification, and is class 1 laser eye safe.
2. These are unfiltered 20-80% values.
3. An eye diagram (Figure 9) specifies laser transmitter pulse response characteristics. The characteristics include rise time, fall time, pulse undershoot, and ringing, all of which are controlled to prevent excessive degradation of the receiver sensitivity. The referenced Gigabit Ethernet eye diagram using the required filter specifies these parameters. The output optical waveform complies with the requirements of the eye mask discussed in section 38.6.5 and Fig. 38-2 of IEEE 802.3.
4. TP refers to the compliance point specified in 802.3, section 38.2.1.
5. The receiver sensitivity is measured using a worst case extinction ratio penalty while sampling at the center of the eye. For a 2^{-1} PRBS the receiver will provide output data with better than or equal to $1E-12$ BER.
6. The stressed receiver sensitivity is measured using the conformance test signal defined in 802.3, section 38.6.11. The conformance test signal is conditioned by applying deterministic jitter and intersymbol interference.
7. The stressed receiver jitter is measured using the conformance test signal defined in 802.3, section 38.6.11 and set to an average optical power 0.5 dB greater than the specified stressed receiver sensitivity.
8. In order to meet the 10 km link power budget the transmitter can trade off spectral width and center wavelength as shown in Figure 10.

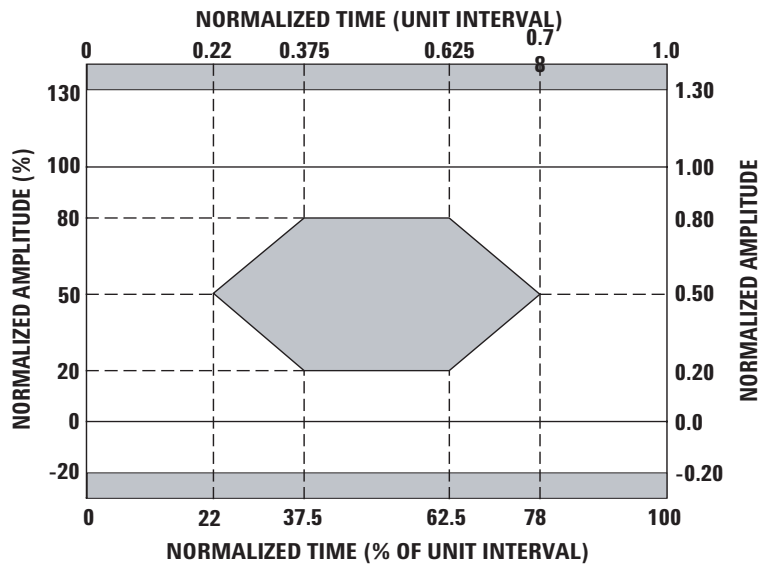

Figure 9. Gigabit Ethernet Transmitter eye mask diagram

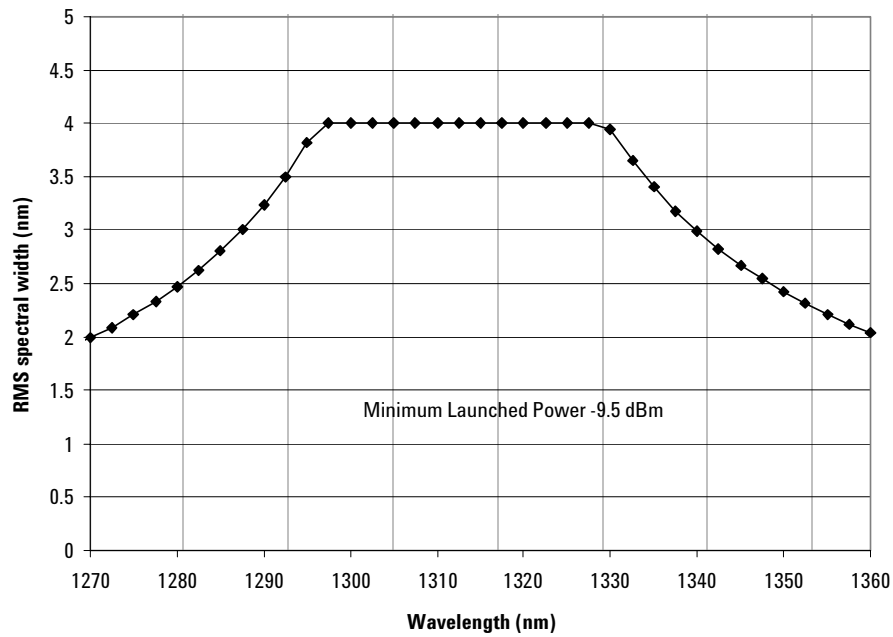

Figure 10. Maximum spectral width trade off curve derived from GigaBit Ethernet link model

Design Support Materials

Avago has created a reference design with HDMP-1687 PHY IC in order to demonstrate full functionality and interoperability. Such design information and results can be made available to the designer as a technical aid. Please contact your Avago representative for further information if required.

Ordering Information

1310 nm FP Laser (Case Temperature range -10°C to +85°C)

HFCT-5911ATL

Related Products

Other single mode Gigabit Ethernet transceivers in this product family are:

HFCT-5914ATL 2x10 DIP

Class 1 Laser Product: This product conforms to the applicable requirements of 21 CFR 1040 at the date of manufacture

Date of Manufacture: _____

Avago Technologies Inc., No 1 Yishun Ave 7, Singapore

Handling Precautions

1. The HFCT-5911ATL can be damaged by current surges or overvoltage. Power supply transient precautions should be taken.
2. Normal handling precautions for electrostatic sensitive devices should be taken.

For product information and a complete list of distributors, please go to our web site: www.avagotech.com

Avago, Avago Technologies, and the A logo are trademarks of Avago Technologies, Limited in the United States and other countries. Data subject to change. Copyright © 2008 Avago Technologies Limited. All rights reserved. Obsoletes 5988-7982EN 5988-8139EN - February 18, 2008

Avago
TECHNOLOGIES