

HFBR-1712TZ

High Performance 850nm Transmitter
for extended link length applications with ST connector



Data Sheet

Description

The high performance miniature 850 nm VCSEL transmitter from Avago Technologies is designed to meet the longer link length requirement for Industrial Control Network. This product can transmit up to 160 MBd digital optical signal. It is packed in a ST-port housing. Compared to an optical link using the LED based HFBR-1414 transmitter, the additional power budget allows more flexibility in system design.

Transmitter

The transmitter uses a VCSEL. The light generated by this VCSEL is efficiently coupled into the fiber which enables high data rates at low power consumption. The transmitter is optimized for small core fiber and typically can launch -8 dBm optical power into 50/125 μm fiber, -5.5 dBm into 62.5/125 μm fiber and -4.5 dBm into 200 μm HCS fiber at 18 mA. The VCSEL laser diodes are 100% burned in to ensure a high reliability in the application. The transmitter is designed to operate with the Avago Technologies HFBR-24xxZ fiber optic receivers.

Package

The transmitter is housed in a low-cost, dual-inline package that is made of high strength, heat resistant, chemically resistant and UL 94V-O flame retardant ULTEM[®] plastic (UL File #E121562). The package is designed for auto-insertion and wave soldering which is ideal for high volume applications.

Handling

Good system performance requires clean port optics and cable ferrules to avoid obstructing the optical path. Dry compressed air often is sufficient to remove dirt particles; methanol on a cotton swab also works well. Each module comes with a protective port plug covering the optics. When soldering, it is advisable to leave the protective plug on to keep the port clean.

Features

- High performance 850 nm Vertical Cavity Surface Emitting Laser (VCSEL) transmitter
- Signalling Rate up to 160 MBd
- Industrial Standard Connector: ST
- Low Power consumption
- Compatible with 50/125 μm , 62.5/125 μm multi-mode and 200 μm HCS[®] Fiber
- 100% Burn-in of VCSEL
- Auto-insertable and wave solderable
- Manufactured in an ISO 9001 certified facility
- Operating Temperature range -20 to +75 °C
- RoHS Compliant
- Threaded Port for easy panel mount

Applications

- Industrial Control Network
- Industrial (Fast-)Ethernet
- Local Area Network

HCS[®] is a trademark of OFS Corporation
ULTEM[®] is a trademark of GE Corporation

Package Dimensions

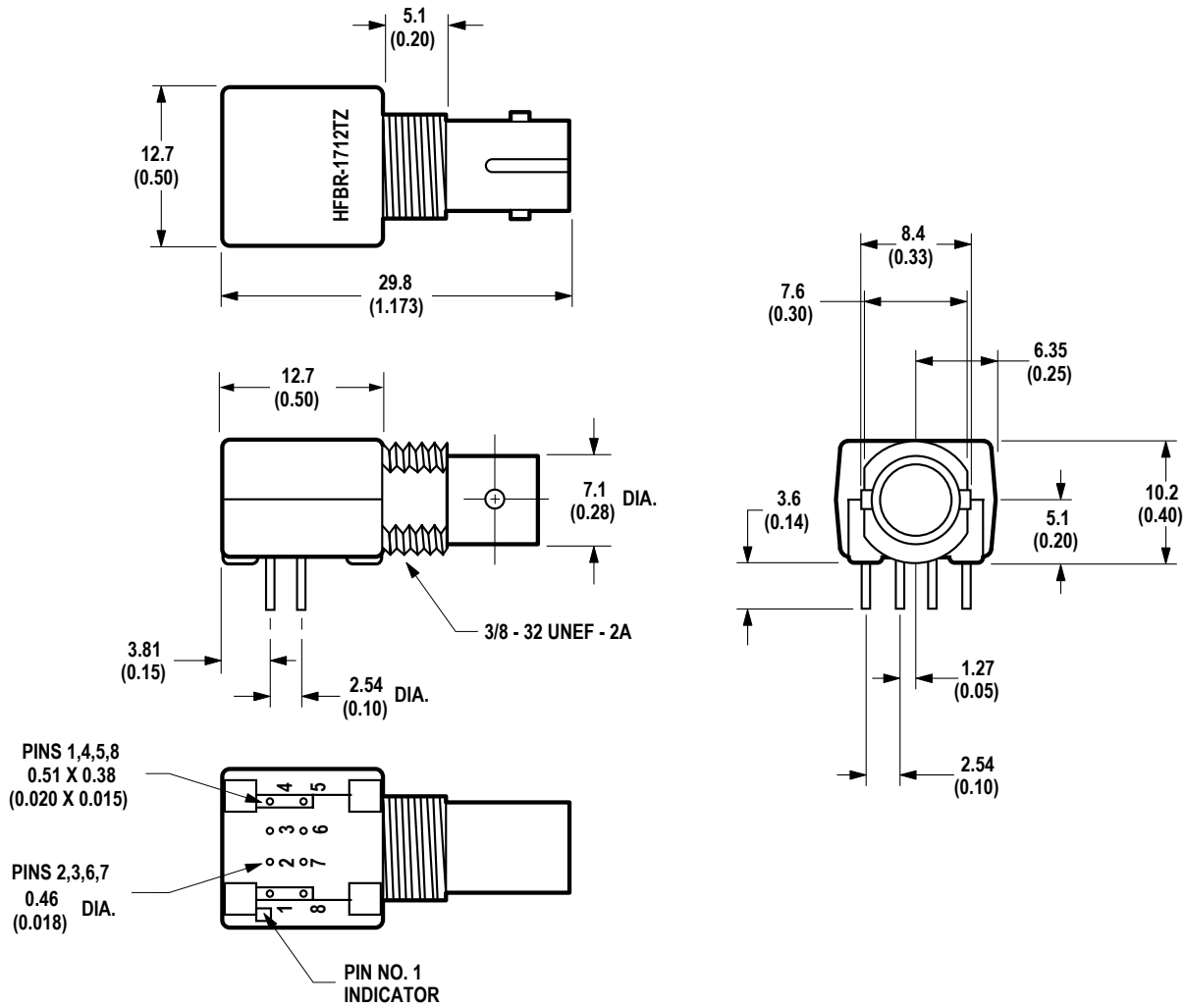

Units in mm.

Pin	Function
1	N.C.
2	N.C.
3	Cathode
4	N.C.
5	N.C.
6	Anode
7	N.C.
8	N.C.

Regulatory Compliance Table

Feature	Test Method	Performance
MIL-STD 883	Method 3015	ESD resistance Human Body Model , - Class 1A (>250, <500V)
EN60825-1	As specified in IEC 60825-1 version 1.2	Class 1 , - TÜV Certification number: R72063430

Absolute Maximum Ratings

Stresses in excess of the absolute maximum ratings can cause catastrophic damage to the device. Limits apply to each parameter in isolation, all other parameters having values within the recommended operation conditions. It should not be assumed that limiting values of more than one parameter can be applied to the products at the same time. Exposure to the absolute maximum ratings for extended periods can adversely affect device reliability.

Parameter	Symbol	Min	Max	Unit	Notes
Storage Temperature	T_s	-40	+85	°C	
Operating Temperature	T_a	-20	+75	°C	
Lead Soldering Temperature	T_{sold}		260	°C	
Lead Soldering Time	t_{sold}		10	s	
Forward Current	I_F		20	mA	
Reverse Input Voltage	V_{BR}		2	V	$I_F = -10 \mu A$

Transmitter Optical/Electrical Characteristics

-20 °C to +75 °C unless otherwise stated

Parameter	Symbol	Min	Typ	Max	Unit	Notes
Peak Output Power (50/125 μm , NA = 0.2)	P_{T50}	-11		-6	dBm	Note 1,2
Peak Output Power (62.5/125 μm , NA = 0.275)	$P_{T62.5}$	-9		-3	dBm	Note 1,2
Peak Output Power (200 μm HCS, NA = 0.37)	P_{T200}	-6		-2	dBm	Note 1,2
Ferrule wiggle penalty	w			3	dB	Note 1,3
Central Wavelength	λ_c	830	850	860	nm	
Spectral Width - RMS	σ_c			0.85	nm	
Forward Voltage	V_f			2.3	V	
Threshold Current	I_{th}		4.5		mA	
Series Resistance	R_s		35		Ω	

Notes:

1. Measured out of 1 meter fiber
2. Forward Current is 18 mA
3. Ferrule wiggle penalty is defined as the delta between the highest and lowest optical coupled power into an inserted ST ferrule when external forces are applied to the ferrule, 15 mm from the port edge, perpendicular to the optical axis, up to 10 N.

For product information and a complete list of distributors, please go to our web site: www.avagotech.com

Avago, Avago Technologies, and the A logo are trademarks of Avago Technologies, Limited in the United States and other countries. Data subject to change. Copyright © 2007 Avago Technologies Limited. All rights reserved.
AV02-0043EN - October 16, 2007

AVAGO
TECHNOLOGIES