

Absolute encoders - modular bus covers

Solid shaft with clamping or synchro flange

Optical single and multiturn encoders 13 bit ST / 16 bit MT

GXAMW, GXMMW



GXMMW with modular bus cover

Features

- Encoder single- or multiturn / bus cover
- Optical sensing method
- Resolution: singleturn 13 bit, multiturn 16 bit
- Clamping or synchro flange
- CANopen®/DeviceNet/EtherCAT/EtherNet-IP
SAEJ1939/PROFINET/POWERLINK/Profibus/SSI
- Code continuity check optional by bus
- Maximum resistant against magnetic fields

Optional

- Incremental outputs and stainless steel design

Technical data - electrical ratings

Voltage supply	10...30 VDC
Reverse polarity protection	Yes
Consumption w/o load	≤100 mA (24 VDC)
Initializing time typ.	250 ms after power on
Interfaces	CANopen®, DeviceNet, EtherCAT, EtherNet/IP, Profibus, PROFINET, POWERLINK, SAE J1939, SSI
Device address	Rotary switch in bus cover (type-specific)
Steps per turn	≤8192 / 13 bit
Absolute accuracy	±0.025 °
Sensing method	Optical
Code	Binary
Code sequence	CW/CCW programmable
Incremental output	2048 pulses A90°B (optional)
Interference immunity	DIN EN 61000-6-2
Emitted interference	DIN EN 61000-6-4
Programmable parameters	Steps per revolution Number of revolutions Preset Scaling Rotating direction
Diagnostic functions	Position or parameter error Multiturn sensing
Status indicator	DUO-LED integrated in bus cover
Approval	UL approval / E63076

GXAMW

Function Singleturn

GXMMW

Function Multiturn
Number of turns ≤65536 / 16 bit

Technical data - mechanical design

Size (flange)	ø58 mm
Shaft type	ø10 mm solid shaft (clamping flange) ø6 mm solid shaft (synchro flange)
Flange	Clamping or synchro flange
Protection DIN EN 60529	IP 54 (without shaft seal), IP 65 (with shaft seal)
Operating speed	≤10000 rpm (mechanical) ≤6000 rpm (electric)
Starting acceleration	≤1000 U/s ²
Starting torque	≤0.015 Nm (+25 °C, IP 54) ≤0.03 Nm (+25 °C, IP 65)
Rotor moment of inertia	20 gcm ²
Admitted shaft load	≤20 N axial ≤40 N radial
Materials	Housing: steel Flange: aluminium Bus cover: zinc die-cast
Operating temperature	-25...+85 °C -40...+85 °C (optional)
Relative humidity	95 % non-condensing
Resistance	DIN EN 60068-2-6 Vibration 10 g, 16-2000 Hz DIN EN 60068-2-27 Shock 200 g, 6 ms
Weight approx.	650 g
Connection	Bus cover

Absolute encoders - modular bus covers

Solid shaft with clamping or synchro flange

Optical single and multiturn encoders 13 bit ST / 16 bit MT

GXAMW, GXMMW

Part number

Singleturn

GXAMW. 20

	Interface
3P32	Profibus-DPV0 / cable gland
3PA2	Profibus-DPV0 / connector M12
3V32	Profibus-DPV2 / cable gland
3VA2	Profibus-DPV2 / connector M12
3EA2	PROFINET / connector M12
EPA6	EtherCAT / connector M12
8EA2	EtherNet/IP / connector M12
5EA4	POWERLINK / connector M12
5P32	CANopen® / cable gland
5PA2	CANopen® / connector M12
8P22	DeviceNet / cable gland
8PA2	DeviceNet / connector M12
2PA2	SSI / connector M12
5B32	SAEJ1939 / cable gland
5BA2	SAEJ1939 / connector M12

Flange / Solid shaft

- 0 Clamping flange / ø10 mm, IP 54
- A Clamping flange / ø10 mm, IP 65
- 1 Synchro flange / ø6 mm, IP 54
- B Synchro flange / ø6 mm, IP 65

Multiturn

GXMMW. 20

	Interface
3P32	Profibus-DPV0 / cable gland
3PA2	Profibus-DPV0 / connector M12
3V32	Profibus-DPV2 / cable gland
3VA2	Profibus-DPV2 / connector M12
3EA2	PROFINET / connector M12
EPA6	EtherCAT / connector M12
8EA2	EtherNet/IP / connector M12
5EA4	POWERLINK / connector M12
5P32	CANopen® / cable gland
5PA2	CANopen® / connector M12
8P22	DeviceNet / cable gland
8PA2	DeviceNet / connector M12
2PA2	SSI / connector M12
5B32	SAEJ1939 / cable gland
5BA2	SAEJ1939 / connector M12

Flange / Solid shaft

- 0 Clamping flange / ø10 mm, IP 54
- A Clamping flange / ø10 mm, IP 65
- 1 Synchro flange / ø6 mm, IP 54
- B Synchro flange / ø6 mm, IP 65

CD with file descriptions is not included in the delivery.
You may order them on CD as accessory under part number
Z 150.022.

Absolute encoders - modular bus covers

Solid shaft with clamping or synchro flange

Optical single and multiturn encoders 13 bit ST / 16 bit MT

GXAMW, GXMMW

Accessories

Connectors and cables

11034355	Cable connector M12, 4-pin, on both sides, D-coded, 5 m cable (Z 185.E05)
----------	---

Mounting accessories

10117669	Eccentric fixing, single (Z 119.006)
----------	--------------------------------------

10141255	Adaptor plate for clamping flange for modification into synchro flange (Z 119.013)
----------	--

10117667	Mounting adaptor for encoders with synchro flange (Z 119.015)
----------	---

10125051	Mounting adaptor for encoders with clamping flange (M3) (Z 119.017)
----------	---

10158124	Bearing flange for encoders with synchro flange (Z 119.035)
----------	---

10141132	Spring washer coupling D1=6 / D2=10 (Z 121.C01)
----------	---

Programming accessories

10146710	CD with describing files & manuals (Z 150.022)
----------	--

11034193	Programming cable for encoders with SSI bus cover, CD with software and manual (Z 139.008)
----------	--

Absolute encoders - modular bus covers

Solid shaft with clamping or synchro flange
Optical single and multiturn encoders 13 bit ST / 16 bit MT

GXAMW, GXMMW

Dimensions

GXAMW, GXMMW - clamping flange

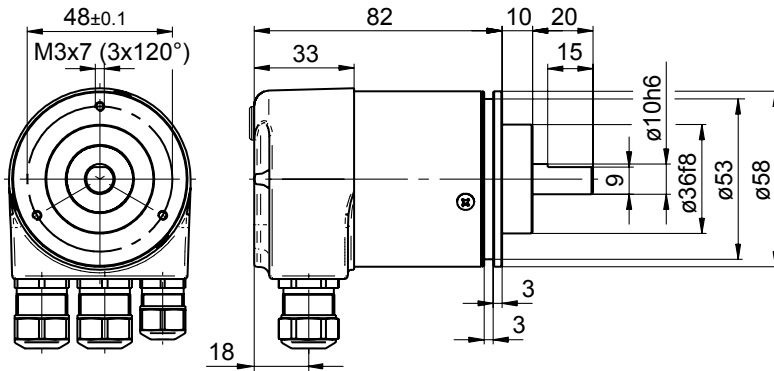

GXAMW, GXMMW - synchro flange

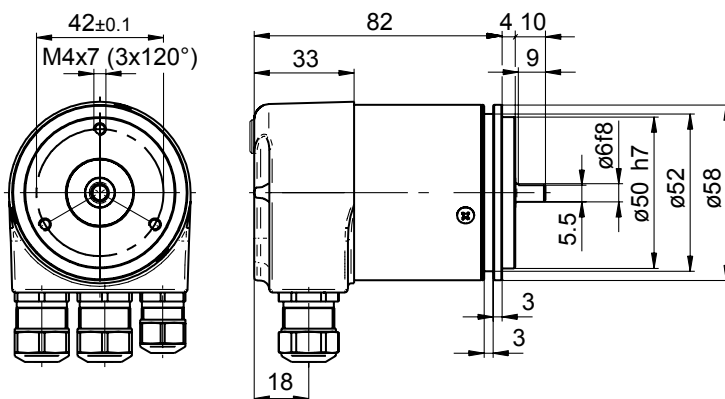

Absolute encoders - modular bus covers

Solid shaft with clamping or synchro flange

Optical single and multiturn encoders 13 bit ST / 16 bit MT

GXAMW, GXMMW

Dimensions

Profibus-DP/CANopen®

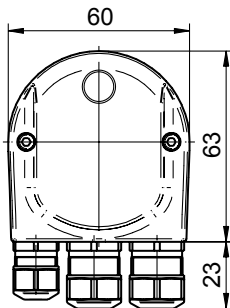

Profibus-DP - M12

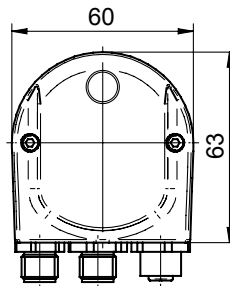

DeviceNet

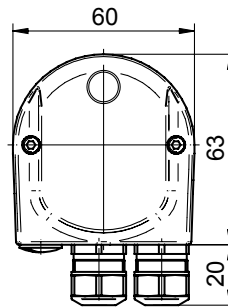

CANopen®/DeviceNet M12

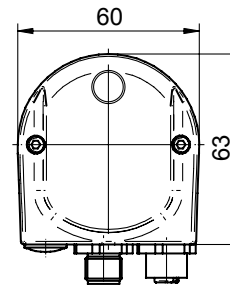

EtherCAT/EtherNet-IP

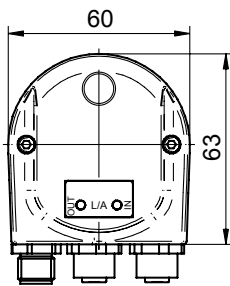

PROFINET/POWERLINK

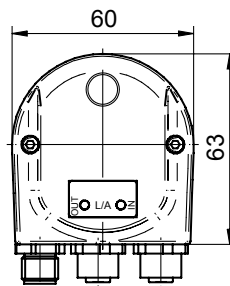

SAEJ1939

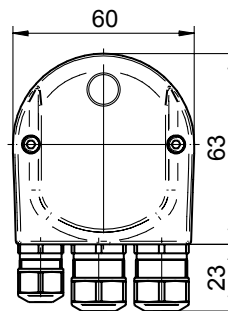

SAEJ1939 - M12

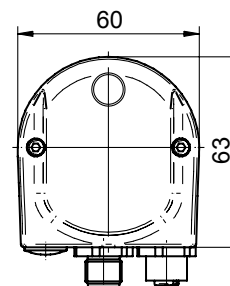

SSI

