



Representative photograph, actual product appearance may vary.

Due to regional agency approval requirements, some products may not be available in your area. Please contact your regional Honeywell office regarding your product of choice.

GTN1A111

GTN Series Hall-Effect Gear-Tooth Sensor; 12 Vdc version; connector position 1; 40 mm probe length

Features

- Senses ferrous metal targets
- Digital current sinking output (open collector)
- Better signal-to-noise ratio than variable reluctance sensors, excellent low speed performance, output amplitude not dependent on RPM
- Sensor electronically self-adjusts to slight variations in runout and variations in temperature, simplifying installation and maintenance
- Measuring range 2Hz to 9 kHz (depending on target)
- Diagnostic detection of sensor power supply
- EMI resistant
- Reverse polarity protection and transient protection (integrated into Hall I.C.)
- Wide continuous operating temperature range

Typical Applications

Heavy Duty Vehicles:

- Camshaft and crankshaft speed and position
- Transmission speed
- Tachometers
- Anti-skid/traction control

Description

GTN Series Hall Effect Gear Tooth Sensors use a magnetically biased Hall effect integrated circuit to accurately sense movement of ferrous metal targets. This specially designed I.C., with discrete capacitor and bias magnet, together with protection and diagnostics circuitry, is sealed in a probe type package for physical protection and cost effective installation.

Output is digital, current sinking (open Collector). Reverse polarity protection is standard. If power is inadvertently wired backwards, the sensor will not be damaged.

An integrated electronic diagnostics feature enables detection of open or short circuits in the power supply line by monitoring levels in the sensor output.

Optimum sensor performance is dependent on the

following variables which must be considered in combination:

- Target material, geometry, and speed
- Sensor/target gap
- Ambient temperature
- Magnetic material in close proximity

Honeywell

GTN1A111

GTN Series Hall-Effect Gear-Tooth Sensor; 12 Vdc version; connector position 1; 40 mm probe length

Product Specifications	
Product Type	Hall-Effect Gear Tooth Sensor
Package Style	Plastic Probe
Supply Voltage	8.0 Vdc to 16.0 Vdc
Output Type	Sink
Termination Type	AMP 3-Pin Connector
Operating Temperature Range	-40 °C to 125 °C [-40 °F to 257 °F]
Output Voltage	3.2 Vdc max. (@ I _o =3 mA)
Vibration	DIN IEC 68-2-6
Salt Spray	96 hours per DIN 50021
Temperature Shock	250 oil-to-oil shock cycles between 20 °C and 125 °C
Vane and Geartooth Target Material	Cold Rolled Steel, 1018 or Low in Carbon (Annealed)
GT Target RPM	15 RPM min., 3600 RPM max.
Switching Time Rise (10 % to 90 %)	30 µs max.
Switching Time Fall (90 % to 10 %)	5.0 µs max.
Operate Point	2.75 ° ± 1.5 °
Release Point	3.0 ° ± 2.50 °
Sealing	IP67, IP68
Availability	Europe only
Comment	Values measured using pull-up resistor; 1 millitesla (1 gauss x 10 ⁻¹), and gear-tooth target dimension.
Supply Current (max. @ 25 °C)	40 mA
Output Current (max.)	15 mA
GT Target Min Tooth Height	5.06 mm [0.200 in]
GT Target Min Tooth Width	2,54 mm [0.100 in]
GT Target Min. Tooth Spacing	10,16 mm [0.400 in]
GT Target Thickness	6,35 mm [0.250 in]
GT Target Diameter	101,6 mm [4 in]
GT Airgap	1,02 mm to 2,03 mm [0.040 in to 0.080 in]
Probe Length	40 mm [1.57 in]

Series Name

GTN Series

Honeywell

GTN1A111

GTN Series Hall-Effect Gear-Tooth Sensor; 12 Vdc version; connector position 1; 40 mm probe length

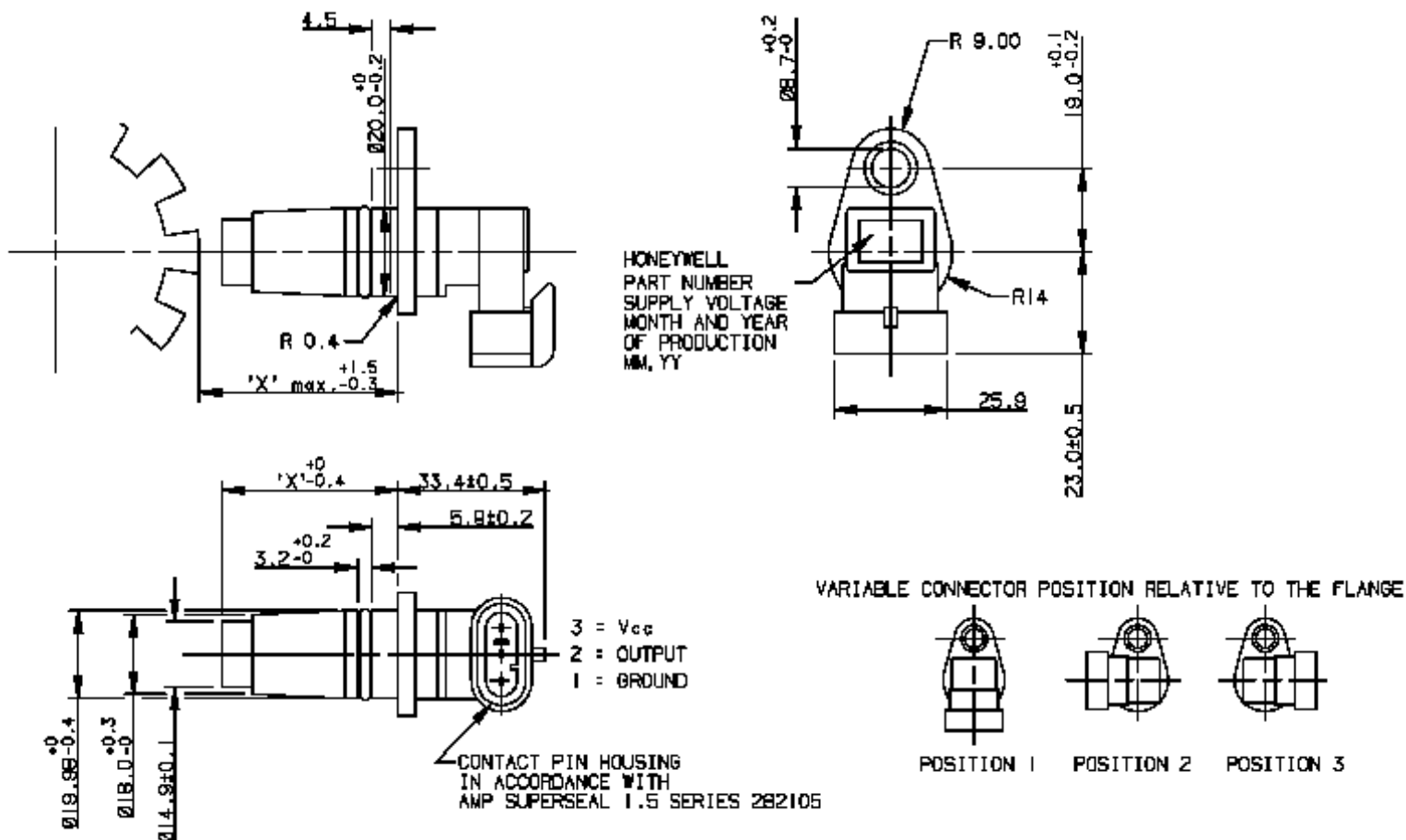

Honeywell

GTN1A111

GTN Series Hall-Effect Gear-Tooth Sensor; 12 Vdc version; connector position 1; 40 mm probe length

⚠ WARNING

PERSONAL INJURY

DO NOT USE these products as safety or emergency stop devices, or in any other application where failure of the product could result in personal injury.

Failure to comply with these instructions could result in death or serious injury.

⚠ WARNING

MISUSE OF DOCUMENTATION

- The information presented in this product sheet (or catalog) is for reference only. DO NOT USE this document as product installation information.
- Complete installation, operation and maintenance information is provided in the instructions supplied with each product.

Failure to comply with these instructions could result in death or serious injury.

© Copyright Honeywell Inc.1998-2006 All rights reserved.