

SiRFstarIV™ GSD4e

Description

SiRFstarIV™ GSD4e WLCSP is a complete navigation processor built on a low-power RF CMOS single-die, incorporating the baseband, integrated navigation solution, software, ARM7 processor, and RF functions that form a complete internal ROM-based standalone or Aided-GPS engine.

GSD4e WLCSP is based on the new SiRFstarIV architecture. GSD4e WLCSP lowers BOM costs and risk while delivering industry-leading GPS performance in a compact solution. GSD4e WLCSP serves the traditional GPS engine market because it can generate a PVT solution without relying upon host device processing power or other resources.

Watch the latest video demo on: [GPS Watches](#)

Benefits

SiRFaware™ technology means never having to maintain full power to achieve maximum performance, nor turning the GPS receiver completely off to save power. It breaks the old GPS performance vs power trade-off through the fusion of a new high-performance GPS engine, advanced power management, and a smart sensor interface to achieve high sensitivity hot-start conditions for fast location fixes while drawing only 50-400 µA.

Premium on-chip software provides a new level of continuous location awareness by employing the following advanced technology:

- Opportunistic ephemeris decode and advanced power management allow the GPS receiver to stay in a hot-start condition nearly continuously while consuming very little power
- Local ephemeris prediction, capturing ephemerides, and predicting them three days to one week in advance boosts sensitivity and performance
- Dynamic contextual awareness, temperature monitoring, and MEMS sensors work in concert to conserve power and boost performance

The GSD4e serves the traditional GPS engine market by generating a PVT solution via its 109 MHz ARM7 CPU without relying on host processing power or other resources. The on-chip processor also allows customers to differentiate their products.

High Performance Solution

- High sensitivity navigation engine (PVT) tracks as low as -163dBm
- 48 track verification channels
- SBAS (WAAS or EGNOS)

Adaptive Micropower Controller

- Only 50 to 500µA maintains hot start capability
- <10mW required for TricklePower™ mode

Active Jammer Remover

- Removes in-band jammers up to 80 dB-Hz
- Tracks up to 8 CW jammers

Advanced Navigation Features

- Smart sensor I²C interface
- Interrupt input for context change detection

Tiny Solution Size

- 42-ball WLCSP, 3.5 x 3.2 x 0.6mm, 0.5mm pitch
- Single-SAW support, minimal external BOM of 5 to 6 passives
- External flash memory
- Typical solution footprint: 45mm²

Simple To Use

- Operation from single 1.8V supply
- Fail safe I/O, including RTC and TCXO inputs
- 3.3V compliant integrated TCXO power switch
- Host I²C, SPI and UART supported
- Programmable E-fuse

Product Details

GPS RF

- Integrated LNA
- Single-SAW filter design
- Fractional-N synthesiser
- SPI control interface
- TCXO input (crystal oscillator input/output supported)

Key Features

- High performance solution
- Adaptive micropower controller
- Active jammer remover
- Advanced navigation features
- Tiny solution size
- Simple to use

- TCXO power control with pre-warm-up capability
- ADC block with selectable 2 and 4-bit quantisation
- Automatic RF circuit tuning with digital read-out and restore by software via SPI messages

GPS Signal Processing

- Enhanced DSP core has more than twice the clock speed and more than double the RAM capacity relative to previous DSP core
- Scanning, detection and tracking of CW tones in IF bandwidth
- CW filtering and excision
- Matched filter acquisition and tracking processing based on DSP core
- Tracking hardware based on DSP core
- Automated internal hardware blanking capability

ARM7TDMI Microprocessor System

- Industry-standard ARM7TDMI CPU core
- Uses internal ROM as code storage for PVT applications
- Separate power domains for E-fuse, DSP core, patch RAM and ARM7TDMI subsystem

Package Option

- 42-ball WLCSP, 3.5 x 3.2 x 0.6mm, 0.5mm pitch
- Integrated Power Management Unit (PMU)
- Primary input is 1.8V:
- All I/O is 1.8V
- Integrated regulators run from 1.8V
- KALDO provides 1.2V non-volatile core voltage supply
- Main switch-mode regulator provides 1.2V baseband and RF core voltage supply
- Low-overhead LDO for 0.96V main core standby voltage supply
- Integrated finite state machine for power sequencing and low-power modes
- Use integrated LDO mode in place of switch-mode regulator for reduced BOM size
- Internal power control allows unswitched external bypass source supply

I/O and Interfaces

- Host port options UART, SPI, I²C
- Additional I²C port for dead reckoning, sensor inputs and serial flash patch source
- Aiding inputs for time and frequency
- Arbitration I/O for multi-function radio coordination
- Tiny footprint as functions are multiplexed
- CMOS I/O runs from 1.8V, is 3.6V tolerant, and failsafe when not powered

Related Images

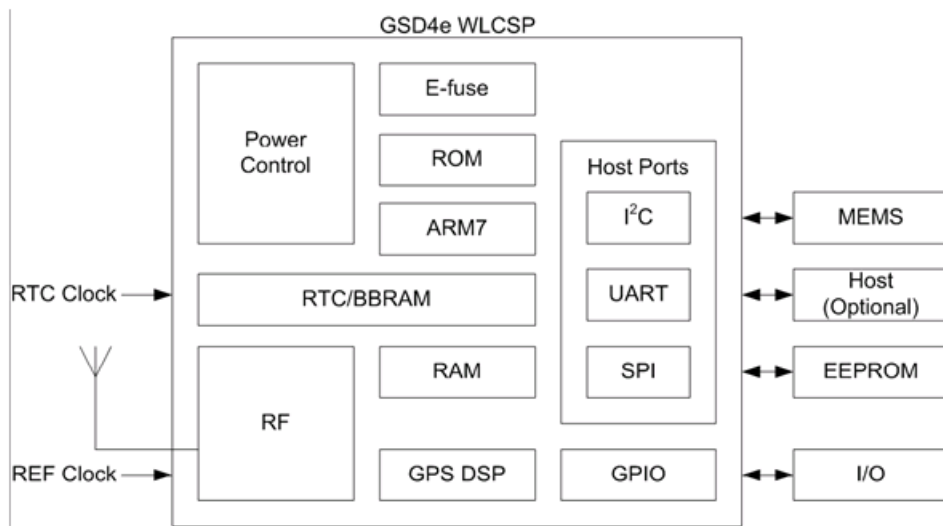

Sirfstarivgsd4e

Sales Offices

Your Local Sales Representative

Click on www.csr.com/contact/sales-representatives to contact your local sales representative.

Source URL: <http://www.csr.com/products/35/sirfstarivgsd4e>