

THIS INFORMATION IS CONFIDENTIAL AND PROPRIETARY TO CW INDUSTRIES INCORPORATED AND ITS AFFILIATES. IT MAY NOT BE DISCLOSED TO ANYONE, OTHER THAN CW INDUSTRIES PERSONNEL, WITHOUT WRITTEN AUTHORIZATION FROM CW INDUSTRIES INCORPORATED, SOUTHAMPTON, PENNSYLVANIA USA.

Rating	16A 125VAC, 10A 250VAC 
	20A 14VDC 10A 28VDC, 6A 14VT
Contact Resistance	50m ohm Max.
Insulation Resistance	DC 500V 100M ohm Min.
Dielectric Strength	AC 1500V 1 minute
Operation Temp.	-20°C ~ 85°C
Switch Function	2P SPST ON-OFF

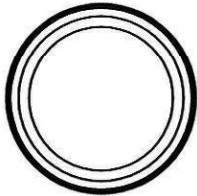

MATERIAL:
Frame: Black, Nylon 66 (94-V2)
Actuator: Black, PC (94-V2)
Waterproof Rubber: Black, Silicone
Terminals: Silver plated, Copper alloy
Hot Stamping: None
Waterproof: IP65

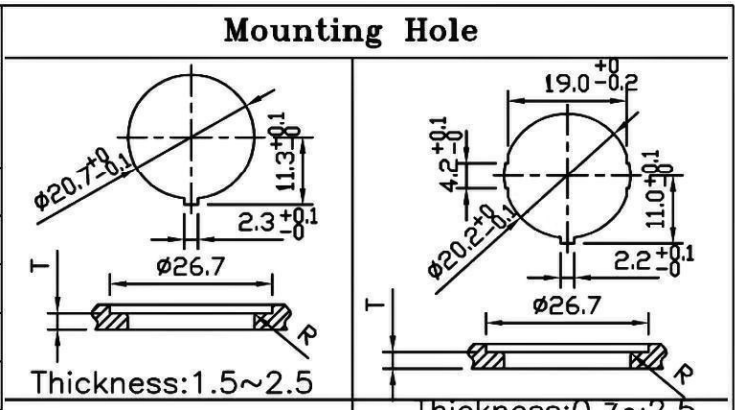
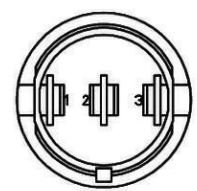
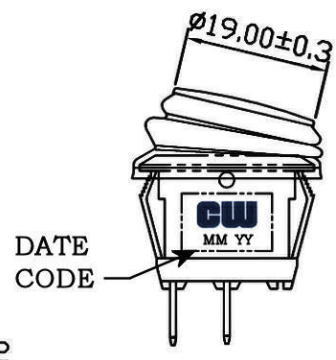
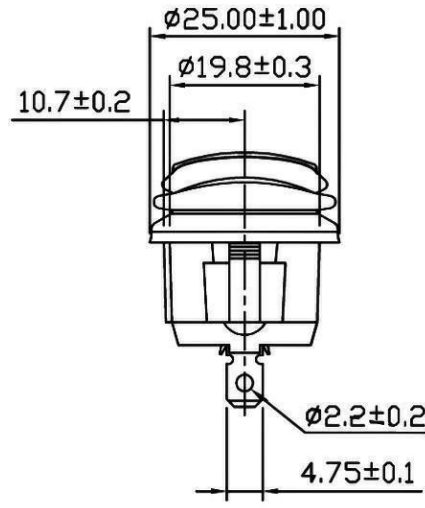
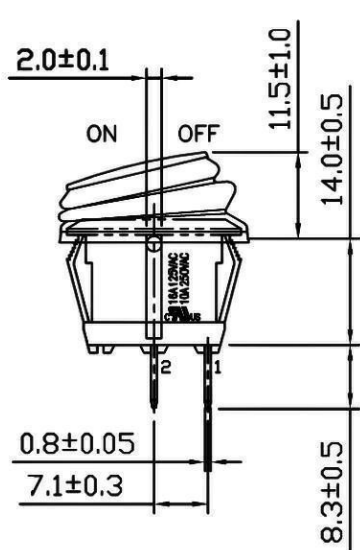
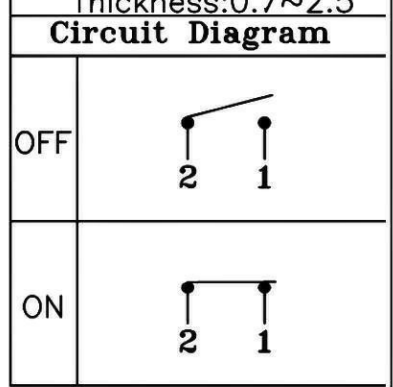

RoHS Compliant

2 Added Date Code. 1/28/11.

CW INDUSTRIES
 Southampton, Pa. 18966
 Tel 215.355.7080/www.cwind.com

Date Drawn: _____
 Title: **ROCKER SWITCH**

Rev. 2 Unit: mm Checked By: **G.Guld**
 CW P/N: **GRB112A802BB**