



TAOGLAS®



Datasheet

GPS & BeiDou Stacked Patch Multi-Band Antenna

Part No:
GPVBSF.25.8.A

Description:

GPS L1 / L5 & BeiDou B1 Single Feed Stacked Patch Antenna

Features:

Single Feed Stacked Patch Assembly

Covering Bands

- GPS L1 & L5
- BeiDou B1

Low Axial Ratio

Pin Mount

Dimensions: 25*25*8.12mm

RoHS & REACH Compliant

| | |
|----------------------------|----|
| 1. Introduction | 3 |
| 2. Specifications | 4 |
| 3. Antenna Characteristics | 5 |
| 4. Radiation Patterns | 8 |
| 5. Mechanical Drawing | 11 |
| 6. Footprint | 12 |
| 7. Packaging | 13 |
| <hr/> | |
| Changelog | 14 |

Taoglas makes no warranties based on the accuracy or completeness of the contents of this document and reserves the right to make changes to specifications and product descriptions at any time without notice. Taoglas reserves all rights to this document and the information contained herein. Reproduction, use or disclosure to third parties without express permission is strictly prohibited.



1. Introduction



The GPVBSF.25.8.A, with Taoglas Sure Technology, is a multi-band GPS, BeiDou/Compass and IRNSS, high-performance directional antenna for high precision GPS and BeiDou accuracy and fast positioning. It utilizes a 25*25*8mm advanced wide-band dual stacked ceramic patch antenna with optimized gain for GPS L1/L5, Galileo and BeiDou bands.

Typical Applications Include:

- RTK
- Navigation
- Wearables
- Security
- Transportation
- Autonomous Vehicles
- Agriculture

The GPVBSF.25.8.A has been tuned and tested on a 70 x 70 mm ground plane and exhibits excellent radiation patterns.

Patch antennas can be specifically tuned to customer-specific device environments, subject to NRE and MOQ. Contact your regional Taoglas customer support team to request these services or additional support to integrate and test this antenna's performance in your device.

2. Specifications

| GNSS Frequency Bands Covered | | | | | | | |
|------------------------------|-----------------|-------------|------------|------------|------------|---------|------------|
| GPS/QZSS | L1 | L2 | L5 | L6 | | | |
| | 1575.42MHz | 1227.6MHz | 1176.45MHz | 1278.75MHz | | | |
| | ■ | □ | ■ | □ | | | |
| GLONASS | L5R | L3PT | L2PT | L1CR | L1PT | | |
| | 1176.45MHz | 1201.5MHz | 1246MHz | 1575.42MHz | 1602MHz | | |
| | ■ | □ | □ | ■ | □ | | |
| Galileo | E5a | E5b | E4 | E3 | E6 | E2 | L1 |
| | 1176.45MHz | 1201.5MHz | 1215MHz | 1256MHz | 1278.75MHz | 1561MHz | 1575.42MHz |
| | ■ | □ | □ | □ | □ | ■ | ■ |
| BeiDou | B1 | B2 | B3 | | | | |
| | 1561MHz | 1207.14MHz | 1268.52MHz | | | | |
| | ■ | □ | □ | | | | |
| Compass | E5B(B2)/ E6(B3) | E2(B1) | | | | | |
| | 1268.56MHz | 1561MHz | | | | | |
| | □ | ■ | | | | | |
| SBAS | Omnistar | WAAS/EGN OS | | | | | |
| | 1542.5MHz | 1575.42MHz | | | | | |
| | □ | ■ | | | | | |

| GNSS Electrical | | | |
|------------------|----------|------|---------|
| Frequency (MHz) | 1176.45 | 1561 | 1575.42 |
| VSWR (max.) | 2:1 | 2:1 | 2:1 |
| Efficiency (%) | 60.8 | 63.9 | 59.6 |
| Peak Gain(dBi) | 2.5 | 3.4 | 3.1 |
| Average Gain(dB) | -3 | -2 | -2.3 |
| Polarization | R.H.C.P. | | |

| Mechanical | |
|-------------------|----------------------|
| Planner Dimension | 25*25*8mm |
| Ground Plane | 70*70mm |
| Connection Type | Pin & Adhesive Mount |

| Environmental | |
|-------------------|----------------------------|
| Temperature Range | -40°C to 85°C |
| Humidity | Non-condensing 65°C 95% RH |

3. Antenna Characteristics

3.1 VSWR

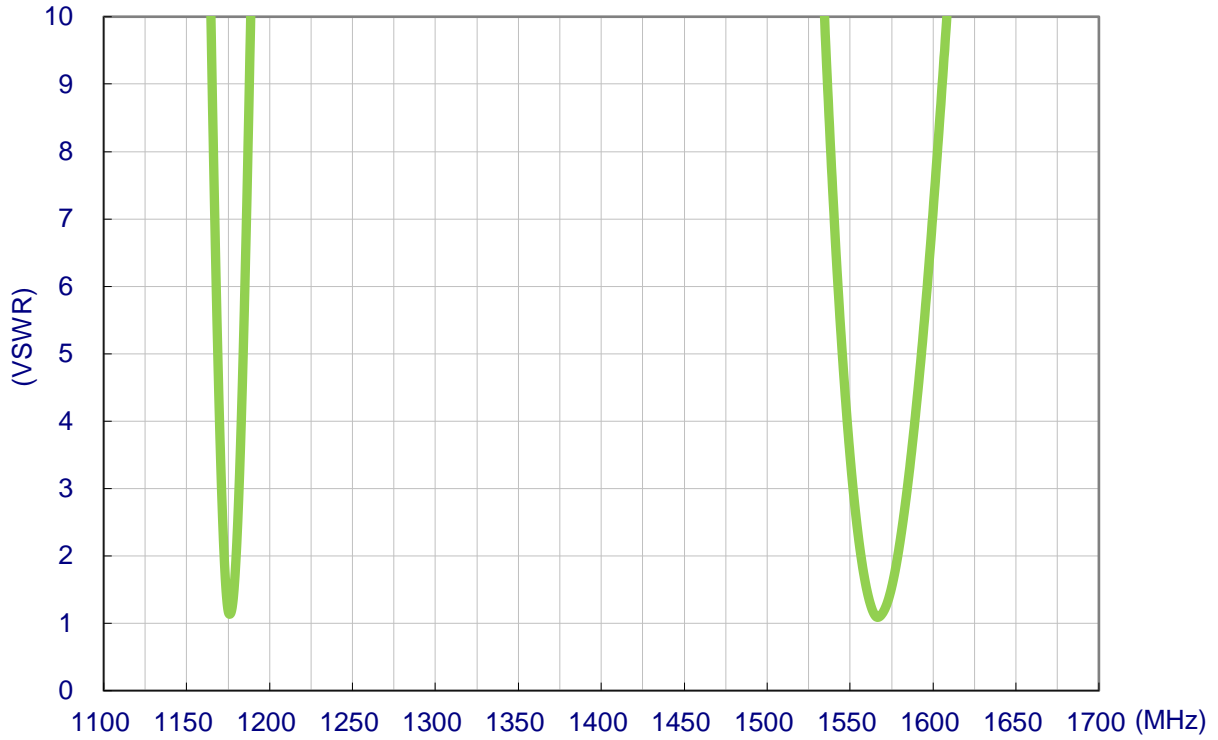

3.2 Efficiency

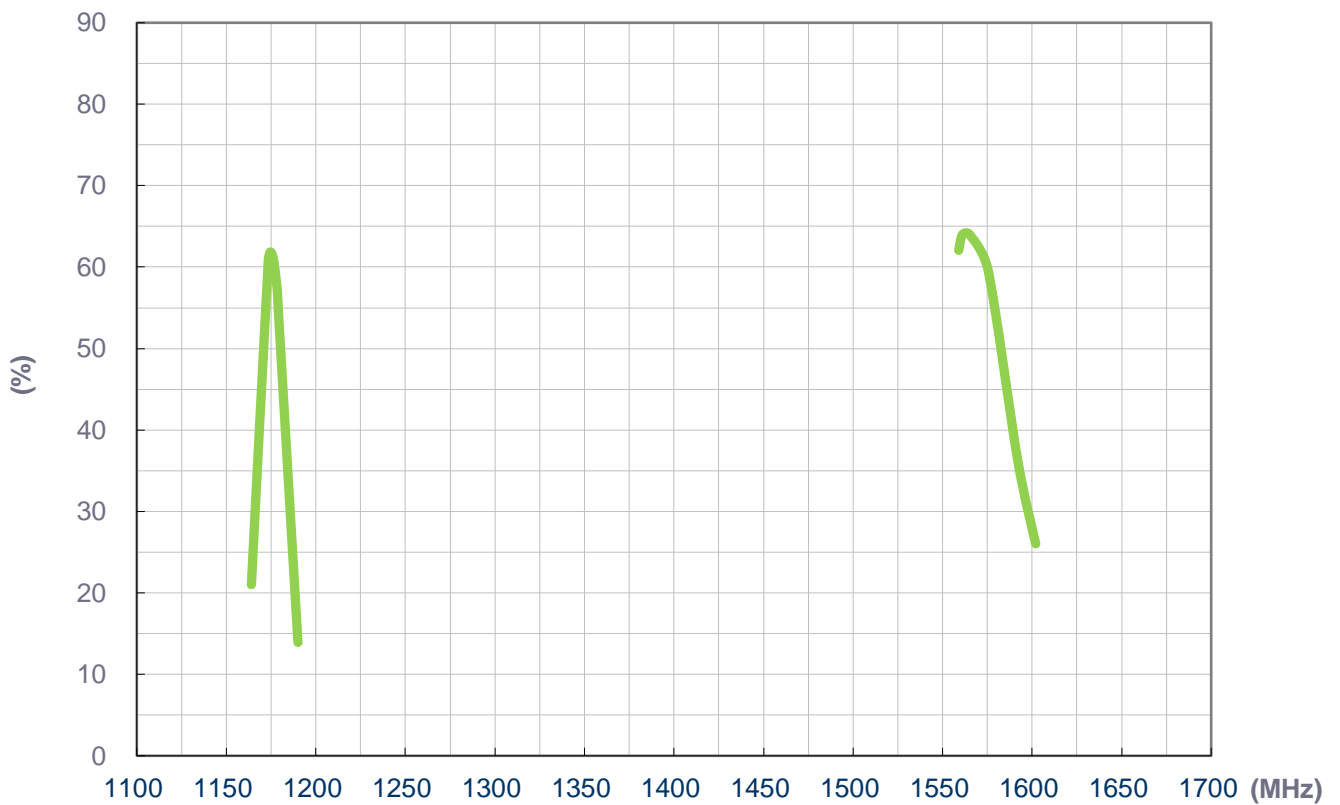

3.3 Average Gain

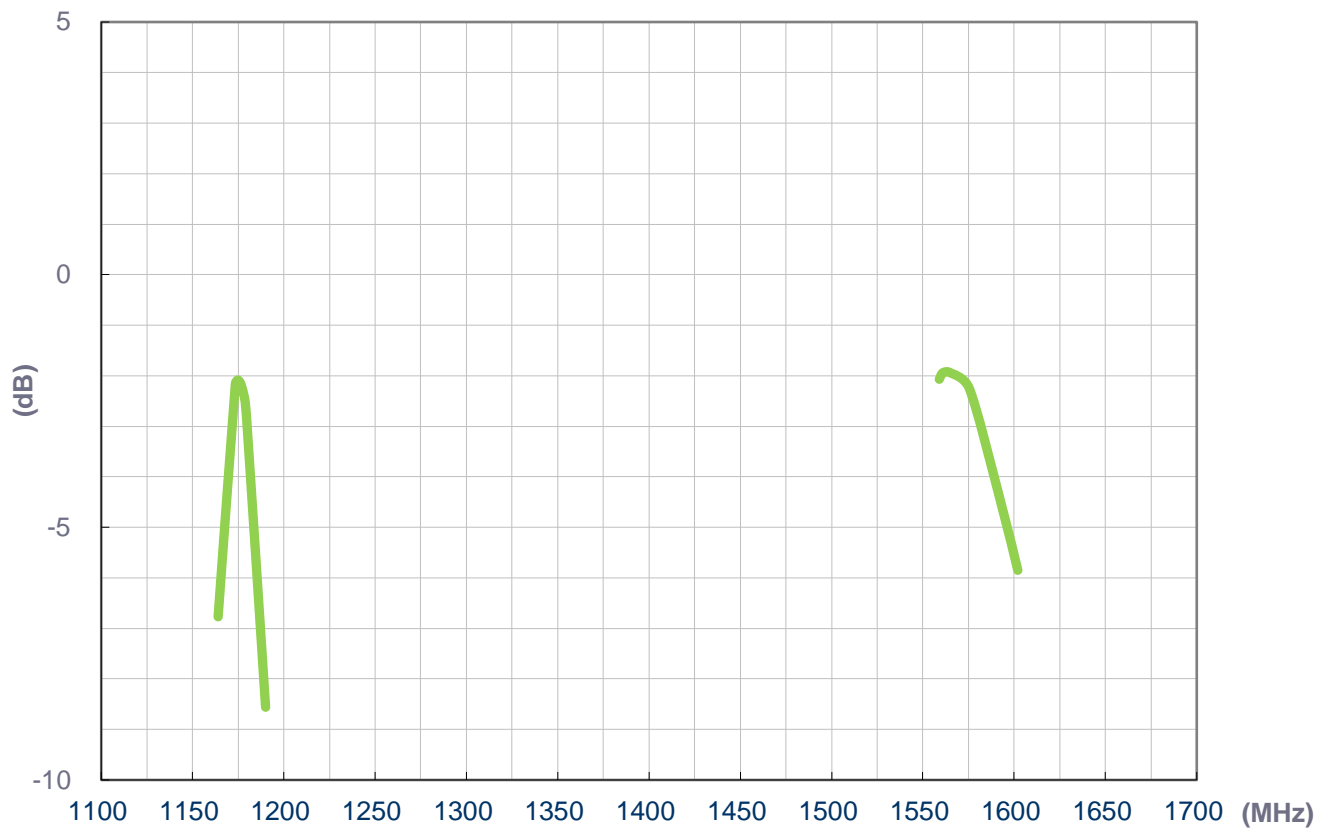

3.4 Peak Gain

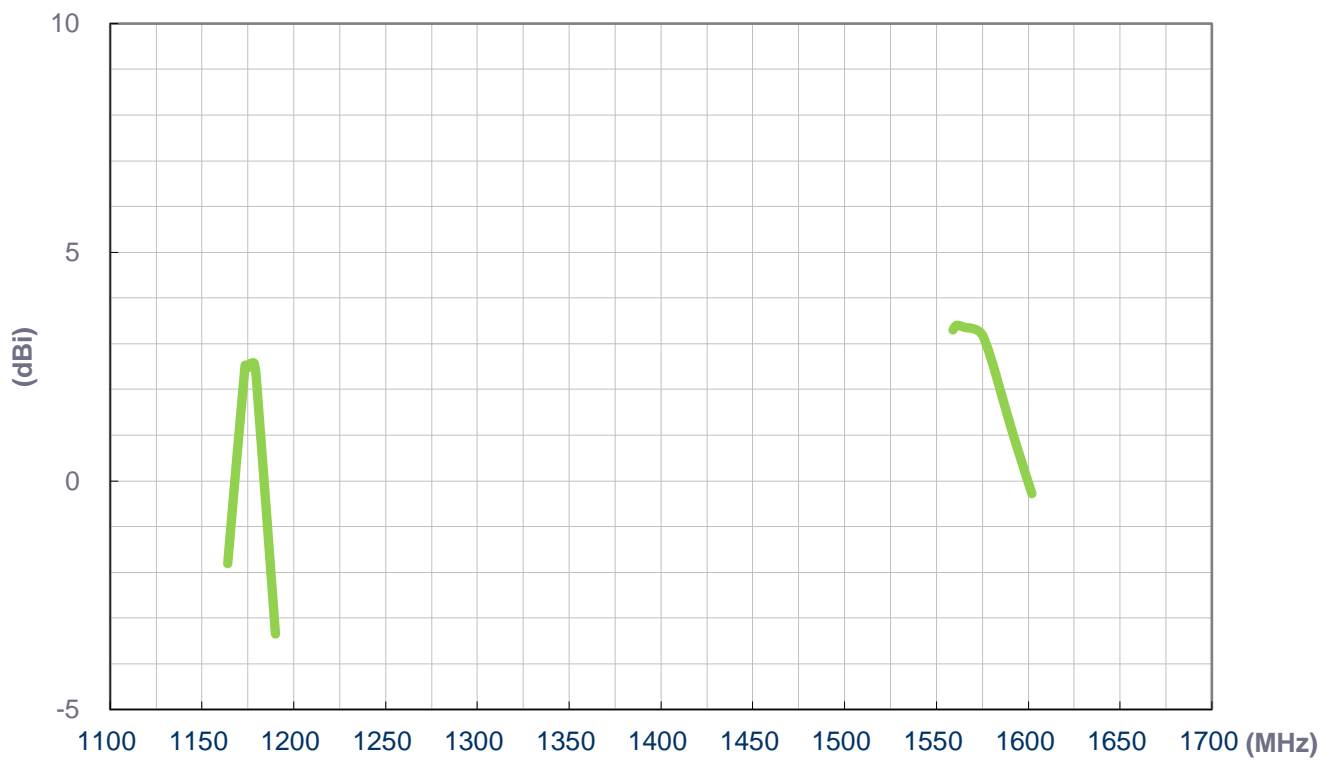

3.5 Axial Ratio – X-Z

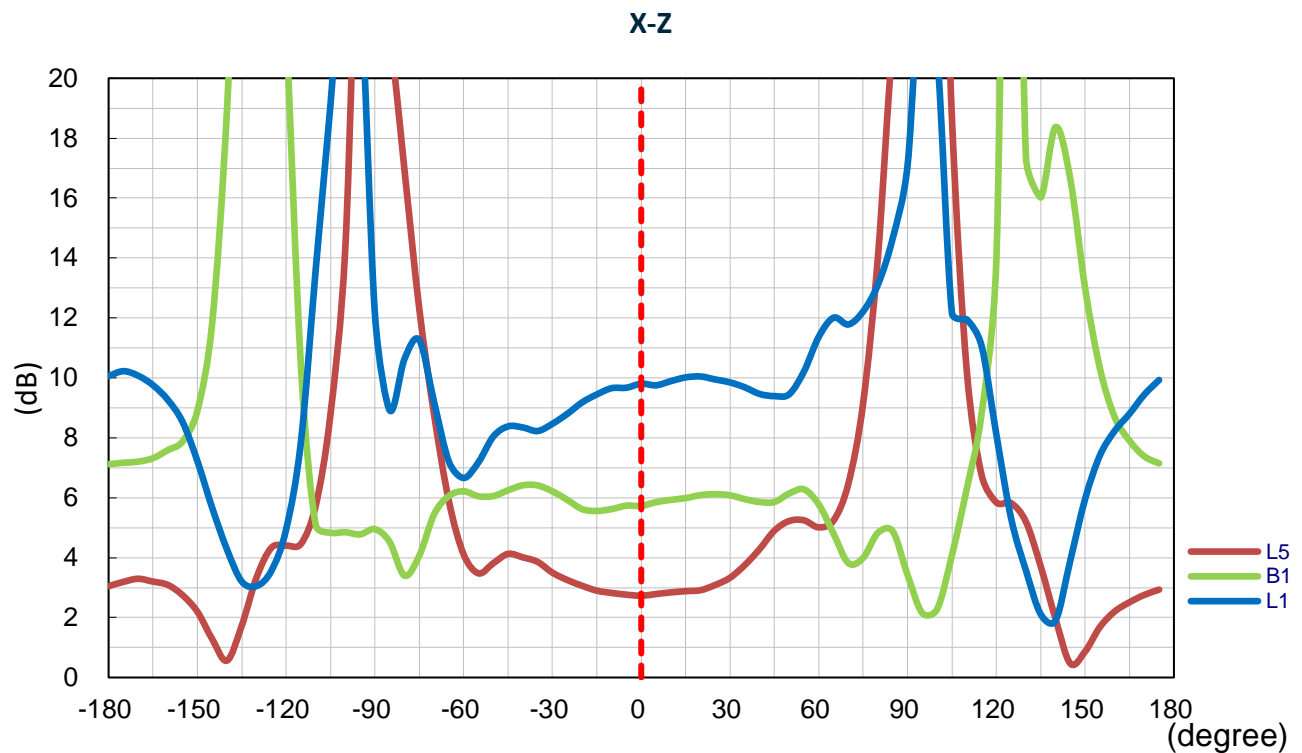

3.6 Axial Ratio – Y-Z

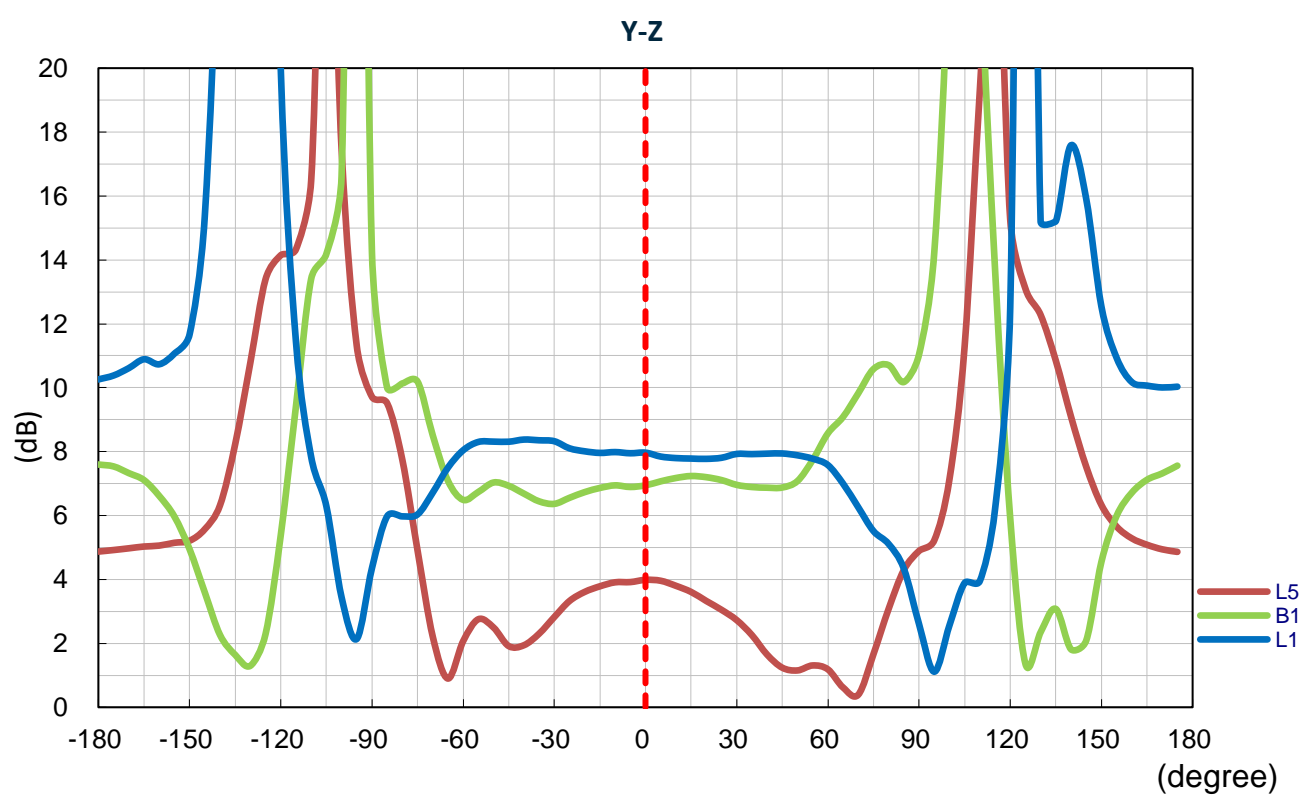

4. Radiation Patterns

4.1 Test Setup

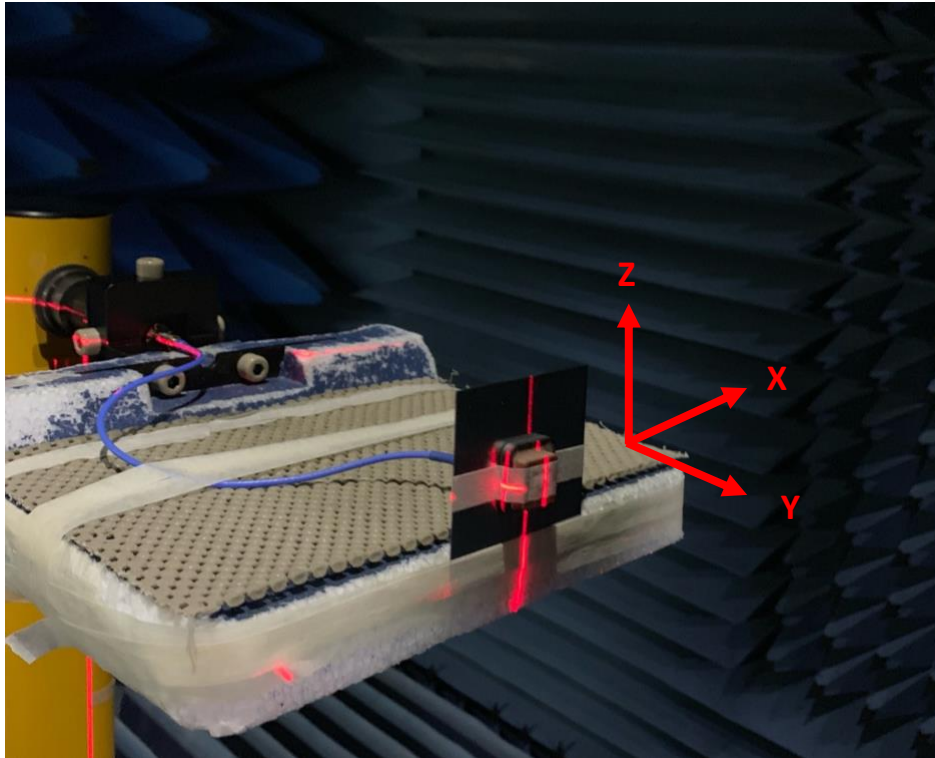

Tested on 70*70mm Ground Plane Evaluation Board

4.2 2D Radiation Patterns

XY Plane

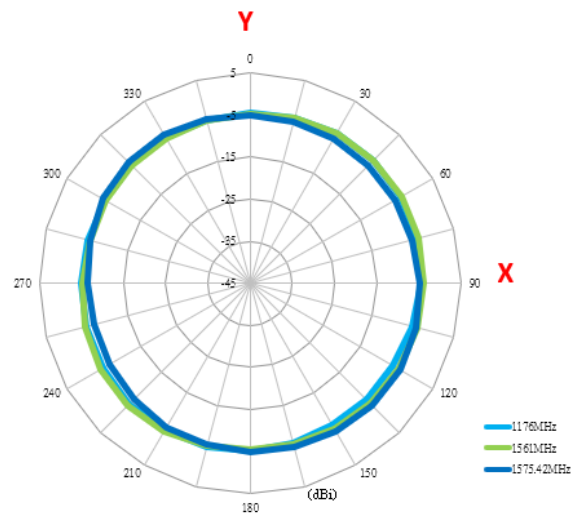

XZ Plane

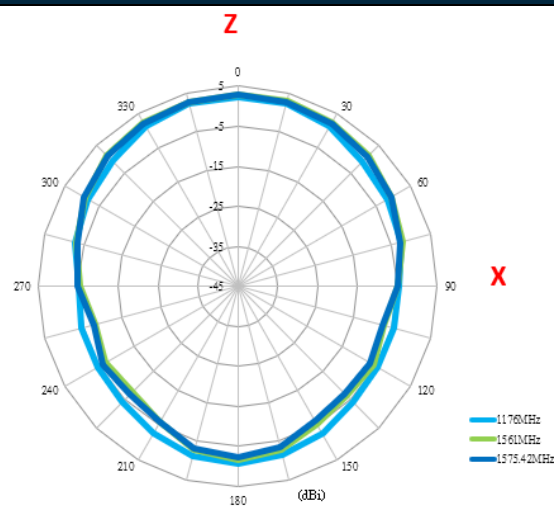

YZ Plane

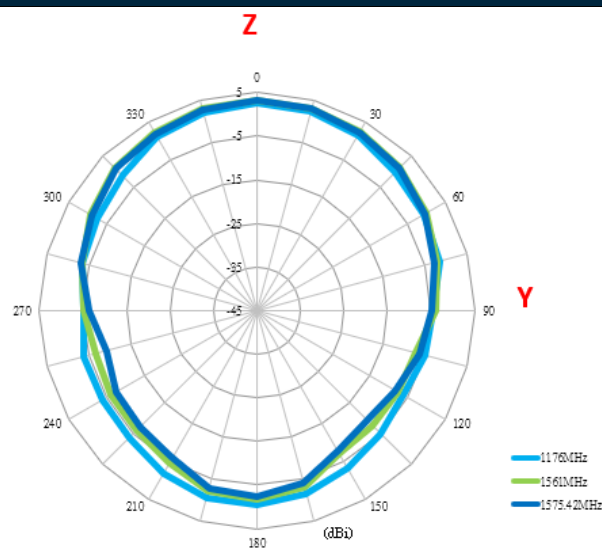

4.3 3D Radiation Patterns

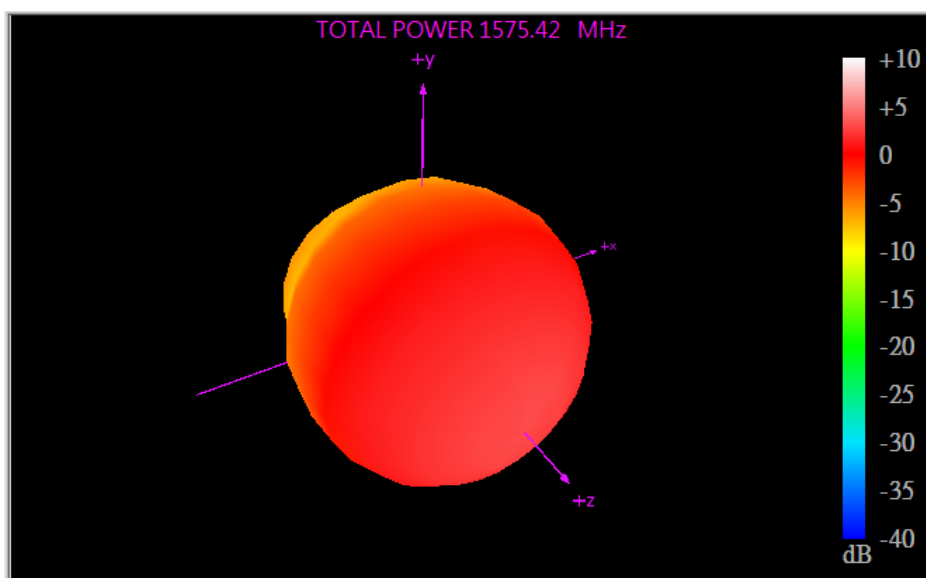
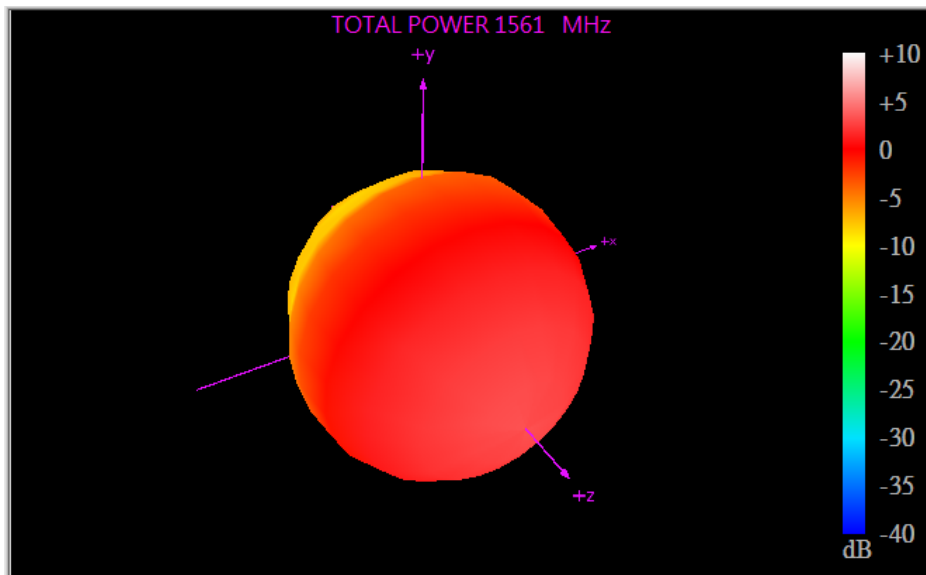
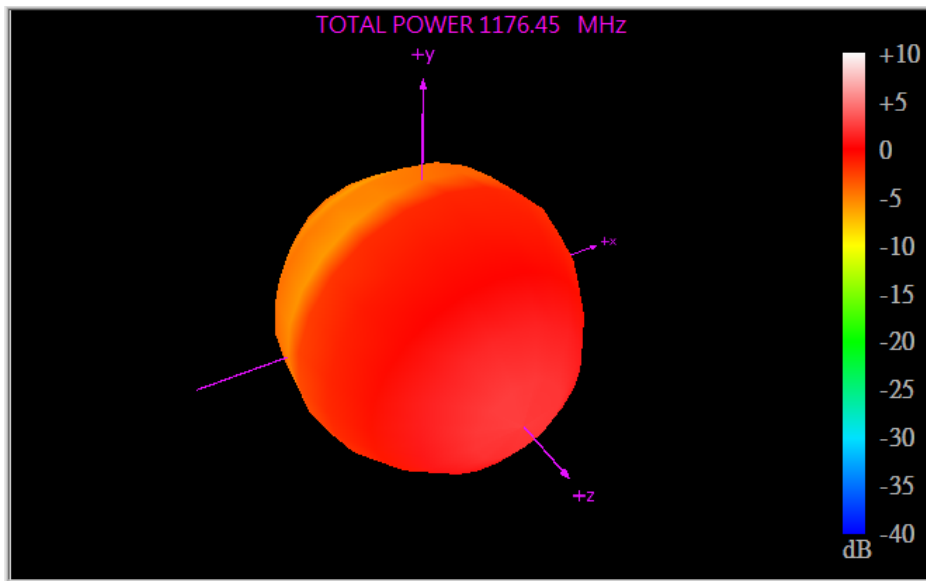

5. Mechanical Drawing (Units: mm)

ISO NO.: EDW-19-8-1549

STATE: Release

NOTES: 1. Double Sided Adhesive Area 2. Soldermask Area

| REV. | DESCRIPTION | ENG. | APPROVED | DATE |
|------|----------------|--------|----------|------------|
| | Initial Design | Tony | Buluto | 2019/11/22 |
| | EC-21-08-010 | Mickey | Buluto | 2021/03/02 |

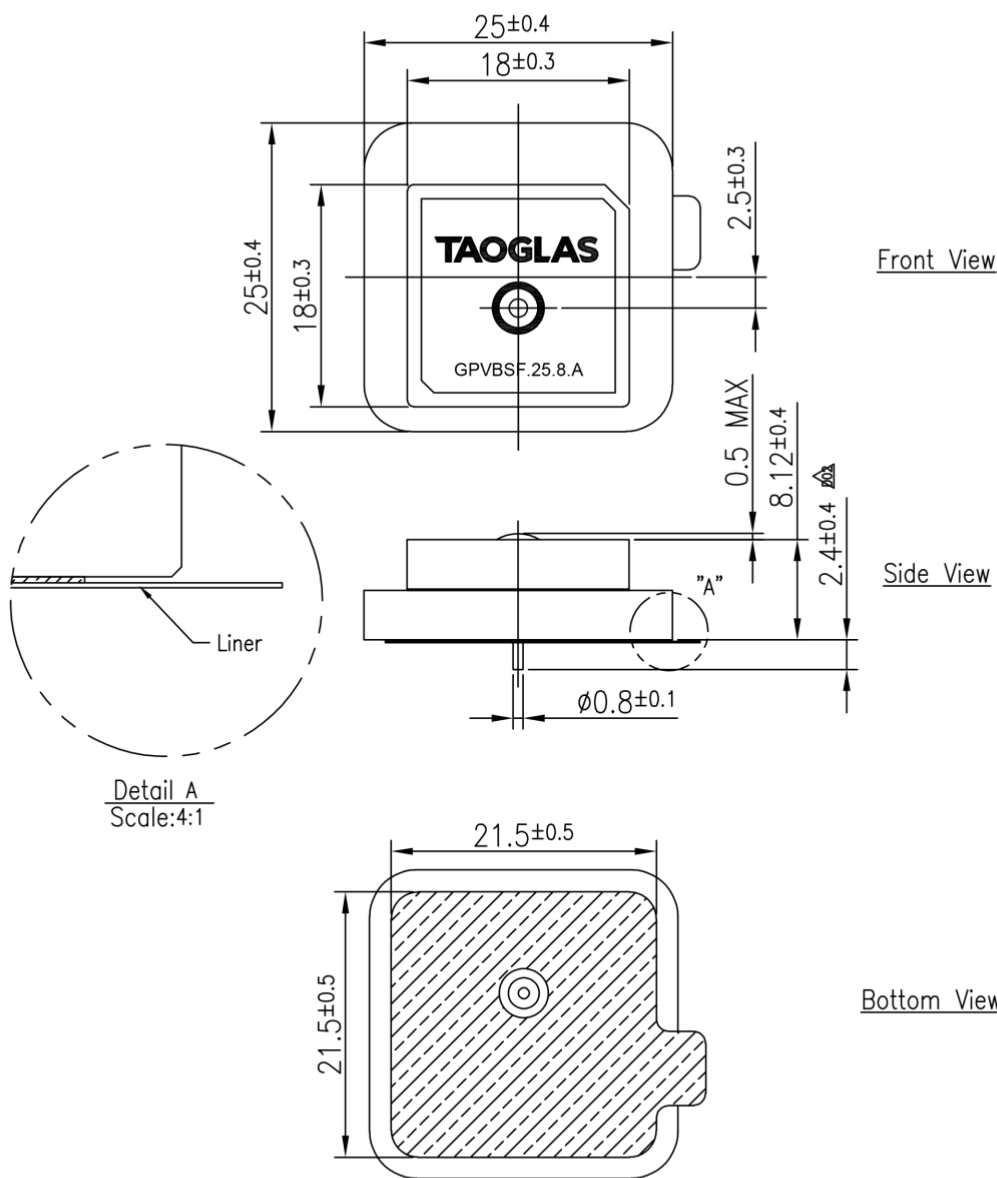

| | Name | P/N | Material | Finish | QTY |
|---|---------------|---------------|----------|--------|-----|
| 1 | Patch(18*18*) | 01348CAW00000 | Ceramic | Clear | 1 |
| 2 | Patch(25*25*) | 01348CAW00000 | Ceramic | Clear | 1 |

| | |
|---|---|
| APPROVED BY: Buluto | TW Design Centre This drawing and its inherent design concepts are property of Taoglas. Not to be copied or given to third parties without the written consent of Taoglas. |
| CHECK BY: Amos | |
| DRAWN BY: Tony | |
| DATE: 2019/11/22 | |
| UNLESS OTHERWISE SPECIFIED TOLERANCES ON: XL±0.5 X±0.3 X±0.2 ØX±0.1 X/2±0.05 | TITLE : GPS Single Feed Stacked Patch Antenna L1:1575.42/1561MHz L5:1176MHz |
| THIRD ANGLE PROJECTION | PART NO. : GPVBSF.25.8.A |
| | UNIT: mm SCALE: 2:1 PAGES: 1/1 REV. D02 |

6. Footprint

Top View

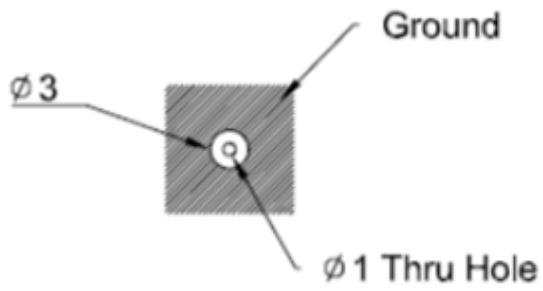

Bottom View

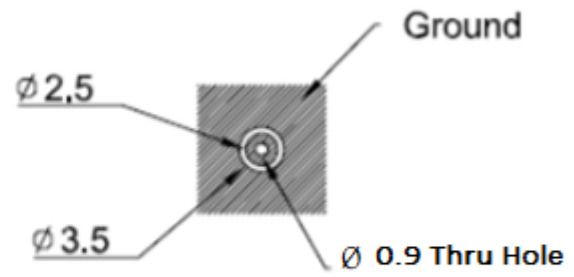

Tolerance: +/- 0,20
Unit:mm

7. Packaging

24pcs GPVBSF.25.8.A per Tray
 Tray Dimensions: 255*144*8mm
 Weight: 0.460Kg

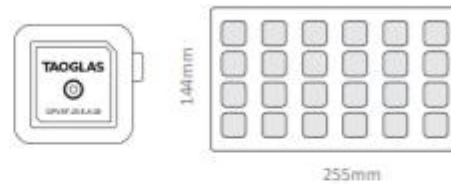

96pcs GPVBSF.25.8.A per Inner Carton
 Dimensions: 263*154*96mm
 Weight: 2Kg

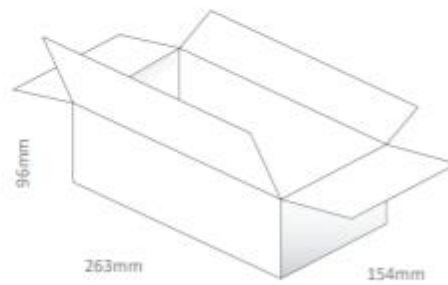

384pcs GPVBSF.25.8.A per Large Carton
 Dimensions: 327*280*218mm
 Weight: 9Kg

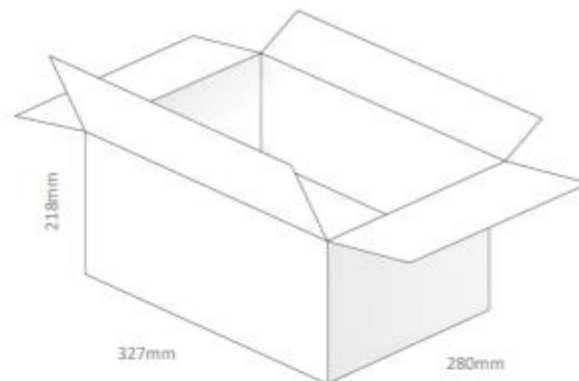

Pallet Dimensions:
 1200*1000*1280mm
 36 Cartons Per Pallet
 9 Cartons Per Layer, 4 Layers

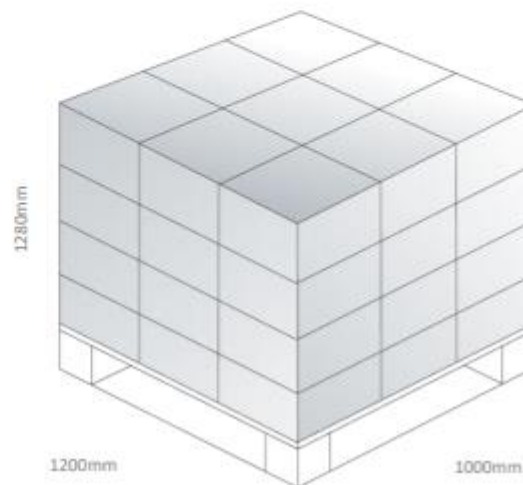

Changelog for the datasheet

SPE-19-8-139 – GPVBSF.25.8.A

Revision: B (Current Version)

| | |
|---------|--|
| Date: | 2021-06-19 |
| Notes: | Updated Pin Length to 2.4mm Updated Drawing |
| Author: | Dan Cantwell |

Previous Revisions

Revision: A (Original First Release)

| | |
|---------|-----------------|
| Date: | 2019-11-07 |
| Notes: | Initial Release |
| Author: | Jack Conroy |



TAOGLAS®

www.taoglas.com

