

PREPARED BY:

DATE:

*Y. Ochi*

*Feb. 1, 2000*

# SHARP

SPEC. No. ED-95004B

ISSUED January 27, 2000

PAGE 11 Pages

APPROVED BY:

DATE:

*O. Ichikawa*

*Feb. 1, 2000*

ELECTRONIC COMPONENTS  
GROUP SHARP CORPORATION  
SPECIFICATION

REPRESENTATIVE DIVISION  
OPTO-ELECTRONIC DEVICES DIV.

DEVICE SPECIFICATION FOR

PHOTOINTERRUPTER

MODEL No.

GP1A73A

1. These specification sheets include materials protected under copyright of Sharp Corporation ("Sharp"). Please do not reproduce or cause anyone to reproduce them without Sharp's consent.
2. When using this product, please observe the absolute maximum ratings and the instructions for use outlined in these specification sheets, as well as the precautions mentioned below. Sharp assumes no responsibility for any damage resulting from use of the product which does not comply with the absolute maximum ratings and the instructions included in these specification sheets, and the precautions mentioned below.

(Precautions)

- (1) This product is designed for use in the following application areas :

- OA equipment    • Audio visual equipment    • Home appliances
- Telecommunication equipment (Terminal)    • Measuring equipment
- Tooling machines    • Computers

If the use of the product in the above application areas is for equipment listed in paragraphs (2) or (3), please be sure to observe the precautions given in those respective paragraphs.

- (2) Appropriate measures, such as fail-safe design and redundant design considering the safety design of the overall system and equipment, should be taken to ensure reliability and safety when this product is used for equipment which demands high reliability and safety in function and precision, such as :

- Transportation control and safety equipment (aircraft, train, automobile etc.)
- Traffic signals    • Gas leakage sensor breakers    • Rescue and security equipment
- Other safety equipment

- (3) Please do not use this product for equipment which require extremely high reliability and safety in function and precision, such as :

- Space equipment    • Telecommunication equipment (for trunk lines)
- Nuclear power control equipment    • Medical equipment

- (4) Please contact and consult with a Sharp sales representative if there are any questions regarding interpretation of the above three paragraphs.

3. Please contact and consult with a Sharp sales representative for any questions about this product.

CUSTOMER'S APPROVAL

DATE  
PRESENTED  
BY

*O. I.*

DATE

BY

O. Ichikawa,  
Department General Manager of  
Engineering Dept..V  
Opto-Electronic Devices Div.  
ELECTRONIC GROUP  
SHARP CORPORATION

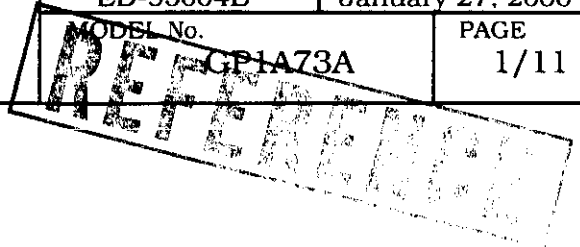

1. Application

This specification applies to the outline and characteristics of transmissive type photointerrupter with connector; Model No. GP1A73A.

2. Outline and Recommended Installation Hole drawing

2.1 Outline : Refer to the attached drawing No. CY6944i02B.

2.2 Recommended Installation Hole drawing :

Refer to the attached drawing No. CY6945i06.

3. Ratings and characteristics

Refer to the attached sheet, page 5 to 7.

4. Reliability

Refer to the attached sheet, page 8.

5. Outgoing inspection

Refer to the attached sheet, page 9.

6. Supplements

6.1 Parts

Refer to the attached sheet, Page 10.

6.2 ODS materials

This product shall not contain the following materials.  
Also, the following materials shall not be used in the production process for this product.

Materials for ODS : CFC<sub>s</sub>, Halon, Carbon tetrachloride,  
1,1,1-Trichloroethane (Methylchloroform)

6.3 Brominated flame retardants

Specific brominated flame retardants such as the PBBO<sub>s</sub> and PBB<sub>s</sub> are not used in this device at all.

6.4 Product mass : Approximately 0.88g

7. Notes

7.1 Truth table (In case of external addition pull-up resistance to Vout terminal)

Light beam	Output
Interrupted	High
Uninterrupted	Low

7.2 In order to stabilize power supply line, connect a by-pass capacitor of more than 0.01  $\mu$ F between Vcc and GND near the device.

7.3 Opaque board shall be installed at place 4mm or more from the top of elements.

(Example)

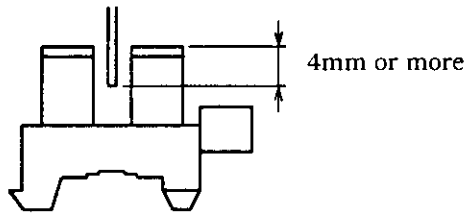

7.4 Please don't carry out immersion cleaning or ultrasonic cleaning to avoid keeping solvent inside case of this device.

7.5 Dust and stain shall clean by air blow, or shall clean by soft cloth soaked in washing materials. And washing material to clean shall be used the below materials only.

Ethyl alcohol, Methyl alcohol, Isopropyl alcohol

2. Outline (Drawing No. CY6944i02B) Scale : 2/1 Unit : 1/1mm

Note) 1. Unspecified tolerance shall be followed the list below.

2. Connector dimensions in parenthesis are shown for reference.

3. Connector made by SUMIKO TECH CO., LTD. is the same as CT connector 175487-3 made by JAPAN AMP.

We guarantee coupling and contact to MT reseptal connector 173977-3 and 179694-3 made by JAPAN AMP.

Dimension	Tolerance
below 5.0	$\pm 0.15$
5.0 or more to below 15.0	$\pm 0.2$
15.0 or more	$\pm 0.3$

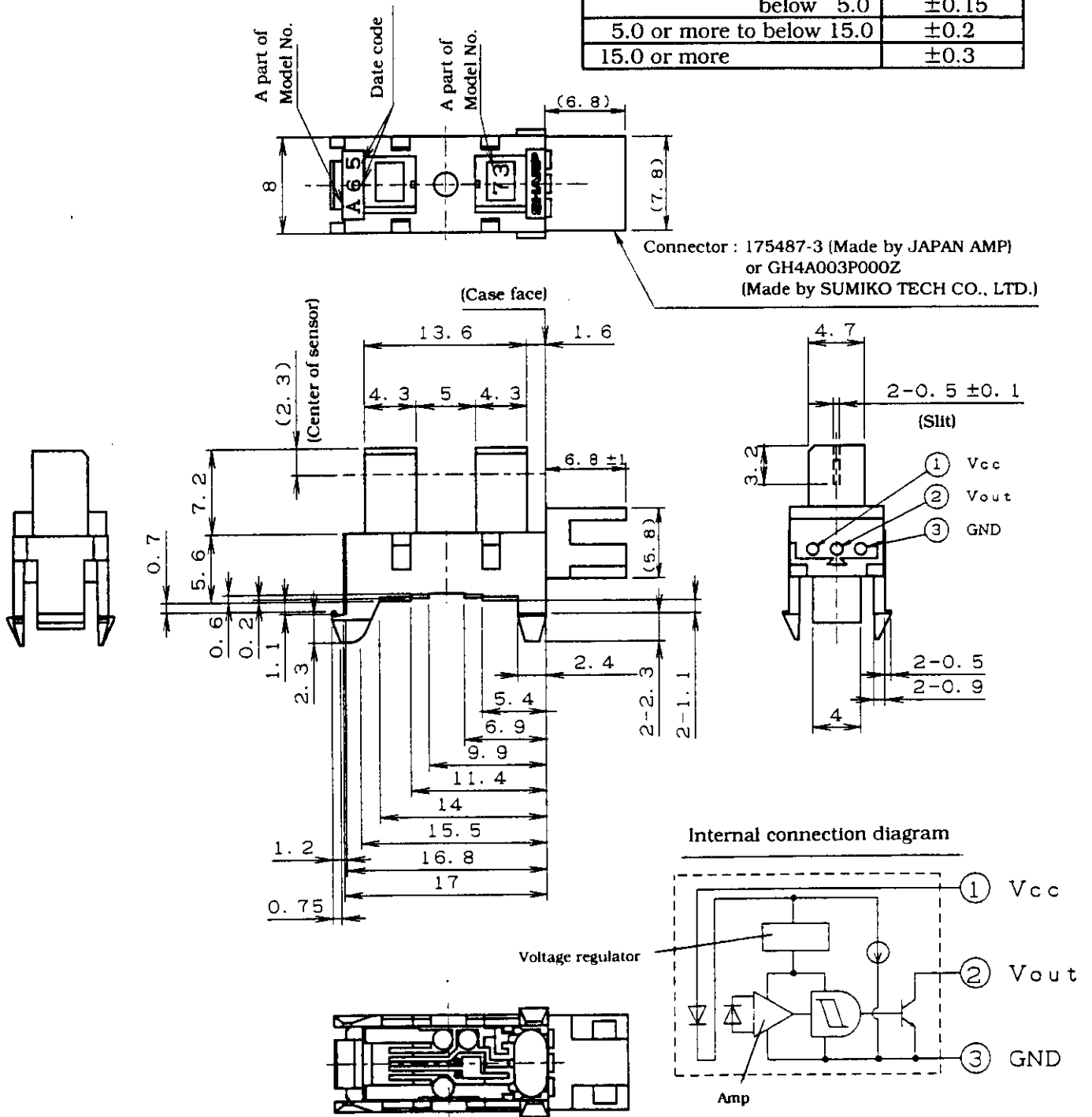

2-2 GP1A73A Recommended Installation Hole drawing  
(Drawing No. CY6945i06)

Unit : 1/1mm

- \*1 We recommend to fix GP1A73A at punching side on the fixing plate (metal plate).
- \*2 Please decide the final dimensions at your side after confirmation by the actual applications, Because mounting efficiency and mounted stabilization are dependent on mounting plate corner-R and punched state.

Normal mounting type

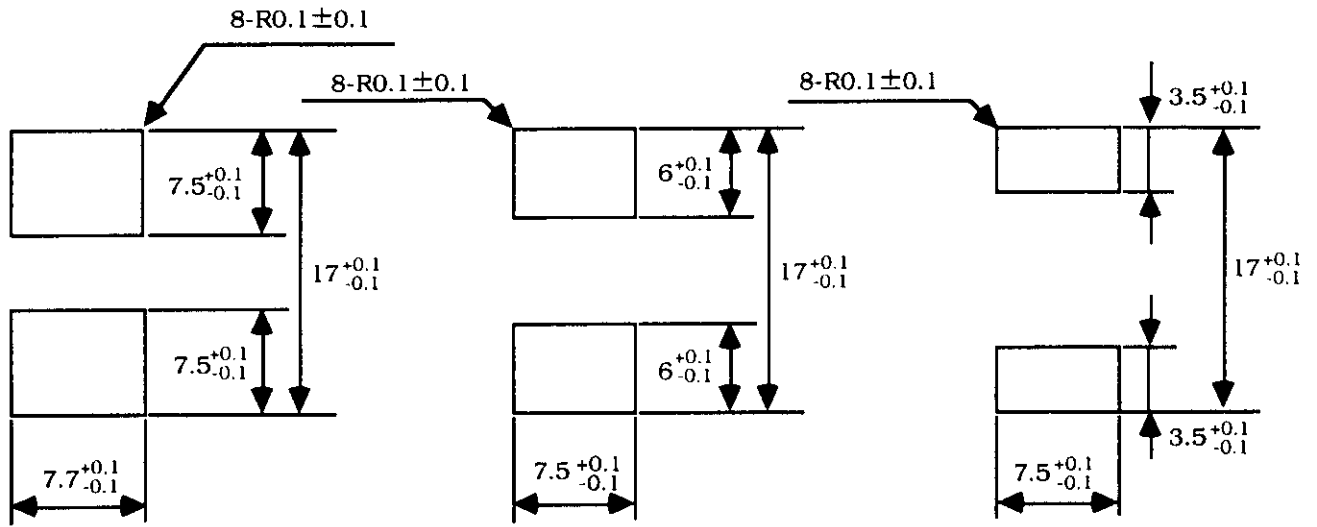

Thickness of plate for 1.6mm

Thickness of plate for 1.2mm

Thickness of plate for 1.0mm

Irregular mounting protection type

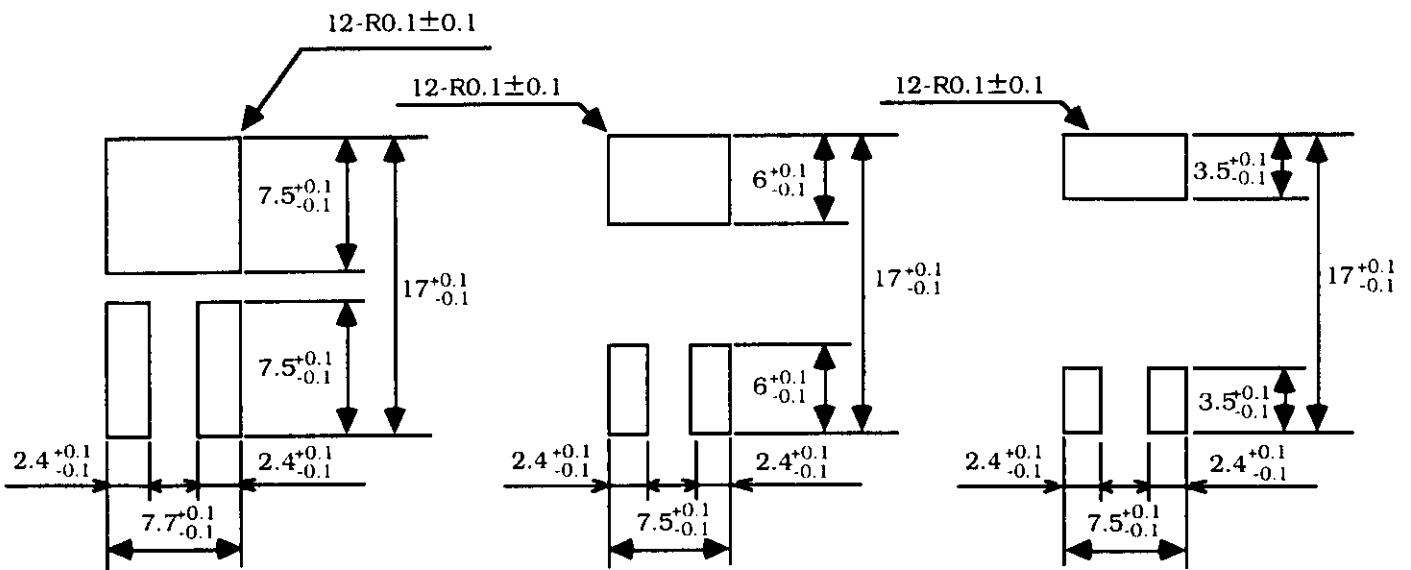

Thickness of plate for 1.6mm

Thickness of plate for 1.2mm

Thickness of plate for 1.0mm

## 3-1 Absolute maximum ratings

Ta=25°C

Parameter	Symbol	Rating	Unit	Remark
Supply voltage	Vcc	-0.5 to +7	V	
Output voltage	Vout	-0.5 to +7	V	Output transistor between collector and emitter
Output current	I <sub>OL</sub>	8	mA	Output transistor collector current *1
Operating temperature	Topr	-20 to +75	°C	The connector should be plugged in/out at normal temperature.
Storage temperature	Tstg	-30 to +85	°C	

\* Fig.1 shows output current vs. ambient temperature.

## 3-2 Electro-optical characteristics

Vcc=5V, Ta=25°C

Parameter	Symbol	Rating	Unit	Conditions
Current dissipation	I <sub>CCL</sub>	16.5 MAX.	mA	Light beam uninterrupted
Low level output voltage	V <sub>OL</sub>	0.35 MAX.	V	Light beam uninterrupted I <sub>OL</sub> =4mA
Current dissipation	I <sub>CCH</sub>	16.5 MAX.	mA	Light beam interrupted
High level output voltage	V <sub>OH</sub>	(Vcc×0.9) MIN.	V	Light beam interrupted R <sub>L</sub> =47kΩ
Operating voltage	Vcc	4.5 to 5.5	V	
Response characteristics	Min. interrupted time	t <sub>H</sub>	166 MIN.	μs R <sub>L</sub> =4.7kΩ
	Min. uninterrupted time	t <sub>L</sub>	166 MIN.	

3-3 Detecting position characteristics (Ta=25°C, Vcc=5V, R<sub>L</sub>=47kΩ)

Horizontal detecting position characteristics

(d=2.35±0.3mm)

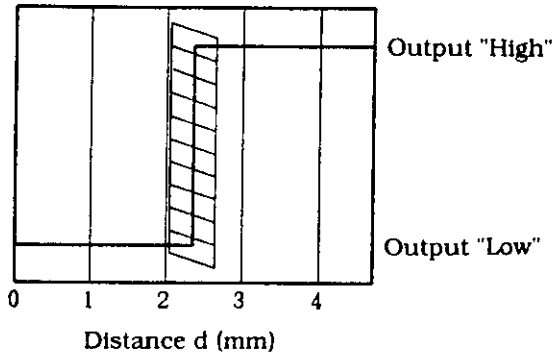

Vertical detecting position characteristics

(d=3.0<sup>+0.3</sup><sub>-.1.8</sub> mm)

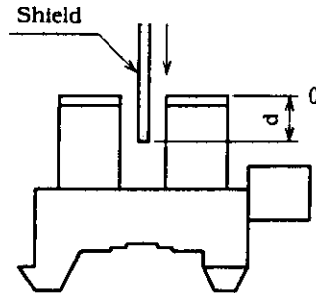
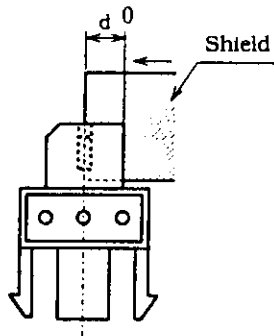
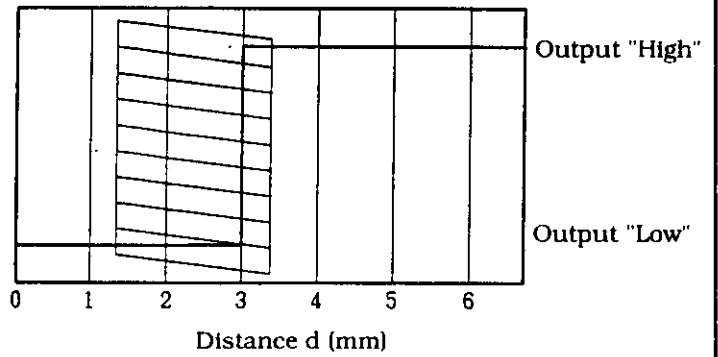
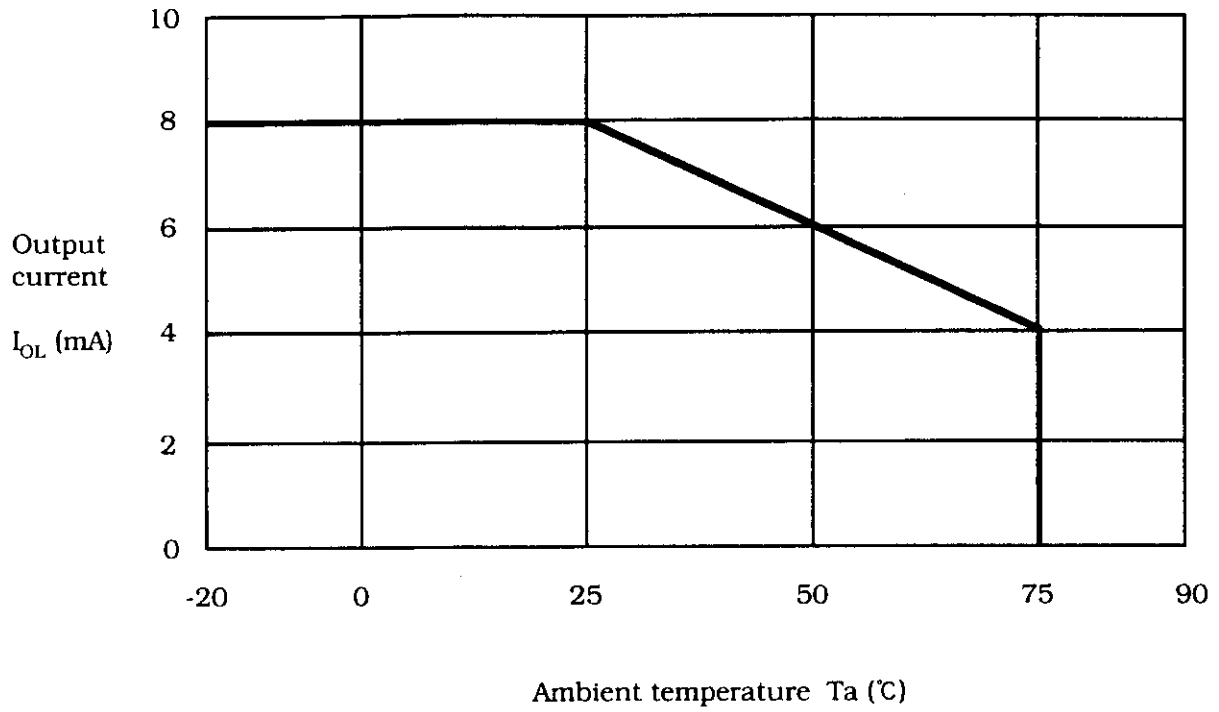

Fig.1 Output current vs. ambient temperature



4. Reliability

The reliability of products shall satisfy items listed below.

Confidence level : 90%  
LTPD : 10%/20%

Test item	Test conditions	Failure Judgement Criteria	Samples (n) Defective(C)
Temperature cycling	1 cycle -30°C to +85°C (20min) (20min) 5 cycles test	$I_{CCL} \geq U \times 1.2$	n=22, C=0
High temp. and high humidity storage	+40°C, 90%RH, 240h	$I_{CCH} \geq U \times 1.2$	n=22, C=0
High temp. storage	Without connector +85°C, 240h	$V_{OL} \geq U \times 1.2$	n=22, C=0
Low temp. storage	-30°C, 240h	$V_{OH} \leq L \times 0.8$	n=22, C=0
Operation life	Vcc=5V, Ta=25±3°C, 1000h	U : Upper specification limit	n=22, C=0
Mechanical shock	1km/s <sup>2</sup> , 3 times/ X, Y, Z direction		n=11, C=0
Variable vibration frequency	Overall amplitude ; 1.5mm Frequency range 10 to 55 to 10 Hz/ 1 min 2h/ X, Y, Z direction		L : Lower specification limit
Connector strength I	Pull connector housing horizontally to connector terminal pin direction by 20N weight for 5 s (1 time)	Abnormal electrical characteristics	n=11, C=0
Connector strength II	Push connector housing perpendicular to connect- or terminal pin direction by 10N weight for 5 s (1 time)		n=11, C=0

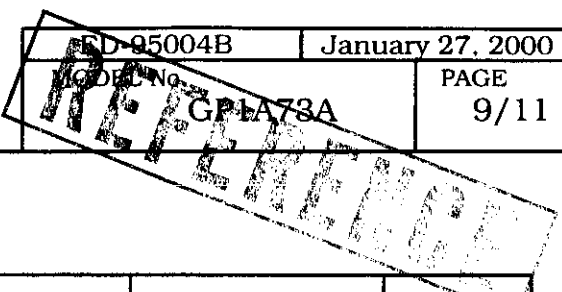

5. Outgoing inspection

	Item	Conditions	Instrument	Judge, Criteria	AQL (%)
1	Appearance	No defects that may conflict with product specifications, including crack, split, chip scratch, burr and blur, No bent connector pin and loosened pin	Visual inspection	Any of the specified defects at left is not acceptable	1.0
2	Electrical characteristics	Specified in para 3-2 ( $I_{CCL}$ , $V_{OL}$ , $I_{CCH}$ , $V_{OH}$ , $V_{CC}$ )	Dedicated tester	Specimen that does not satisfied the requirements specified at left is not acceptable.	0.4

A single sampling plan, normal inspection level II based on ISO 2859 shall be adopted.

6. Supplements

- Parts : This product uses the below parts.

6-1 Light detector (Q'ty : 1)

(Using a silicon photodiode as light detecting portion, and a bipolar IC as signal processing circuit.)

Type	Maximum sensitivity wavelength (nm)	Sensitivity wavelength (nm)	Response time ( $\mu$ s)
Photodiode	900	400 to 1200	10

6-2 Light emitter (Q'ty : 1)

Type	Material	Maximum light emitting wavelength (nm)	I/O Frequency (MHz)
Infrared light emitting diode (Non-coherent)	GaAs	950	0.3

6-3 Material

Case
Black polycarbonate resin (UL 94V-2)

6-4 Others

This product shall not be proof against radiation flux.

Laser generator is not used.

Package drawings

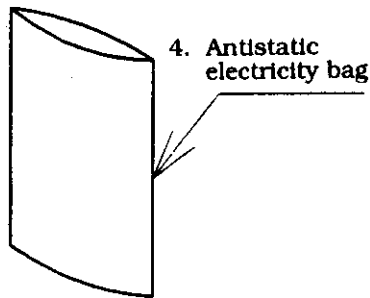
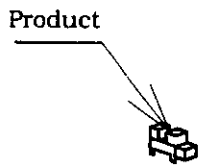

(Fig 1)

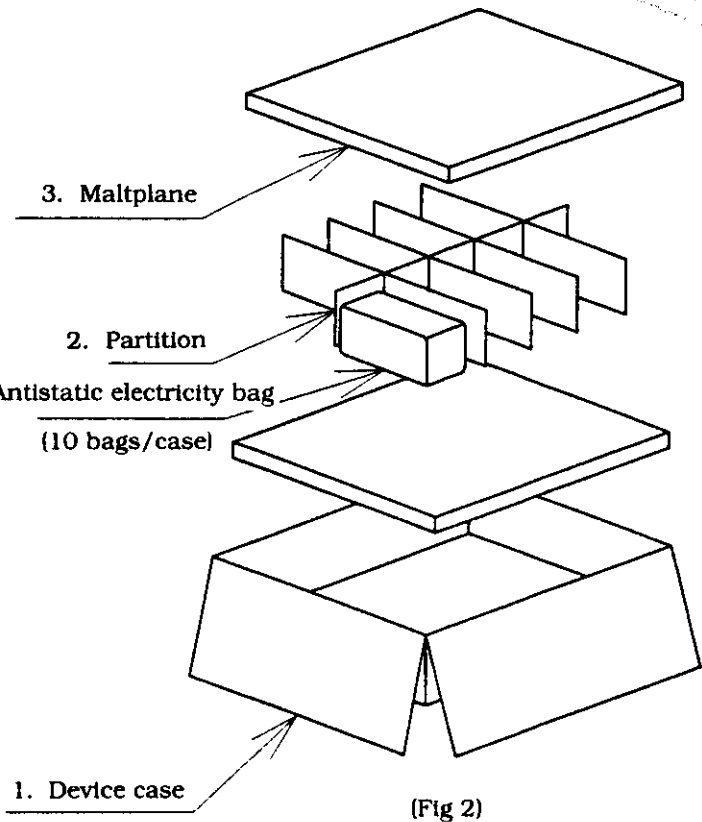

(Fig 2)

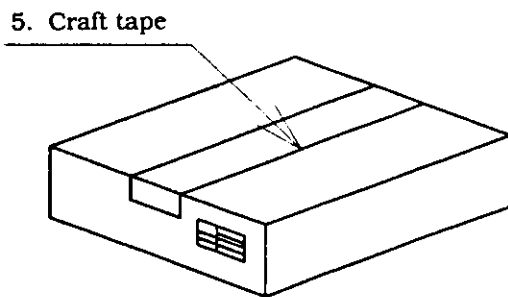

(Fig 3)

Packaging method

No.	Name	Quantity
1	Device case	1/1000
2	Partition	1/1000
3	Maltplane	2/1000
4	Antistatic electricity bags	1/100
5	Kraft tape	-

- Put 100 devices into antistatic electricity bag, and seal. (Fig.1)
  - Put a maltplane and partition into a device case. Put a bag into a partitioned box. (10 bags per case) and put a maltplane. (Fig. 2)
  - Seal device case with craft tape, and stamp model No., quantity, inspection date. (Fig.3)
- (1000pcs./a packing box)  
(Approximately 1.24kg/a packaging mass)