

GA1A1S202WP OPIC Light Detector

Product Specification

November 2007

Surface Mount Detector (555 nm) with Dynamic Range of 3 to 55,000 lx, extended operating temperature range.

SHARP

SPEC. No. ED-07G046
ISSUE November 15, 2007

REFERENCE

OPTO-ANALOG DEVICES DIVISION
ELECTRONIC COMPONENTS GROUP
SHARP CORPORATION

SPECIFICATION

DEVICE SPECIFICATION FOR

OPIC LIGHT DETECTOR

MODEL No.

GA1A1S202WP

Specified for

Enclosed please find copies of the Specifications which consists of 16 pages including cover.
After confirmation of the contents, please be sure to send back copy of the Specifications
with approving signature on each.

CUSTOMER'S APPROVAL

PRESENTED

DATE

DATE

BY

BY



Y. Oda,
Department General Manager of
Engineering Dept., III
Opto-Analog Devices Div.
ELECTRONIC GROUP
SHARP CORPORATION

GA1A1S202WP

REFERENCE

Product name : OPIC LIGHT DETECTOR

Model No. : GA1A1S202WP

1. These specification sheets include materials protected under copyright of Sharp Corporation ("Sharp"). Please do not reproduce or cause anyone to reproduce them without Sharp's consent.
2. When using this product, please observe the absolute maximum ratings and the instructions for use outlined in these specification sheets, as well as the precautions mentioned below. Sharp assumes no responsibility for any damage resulting from use of the product which does not comply with the absolute maximum ratings and the instructions included in these specification sheets, and the precautions mentioned below.

(Precautions)

- (1) This product is designed for use in the following application areas ;

(· OA equipment · Audio visual equipment · Home appliances
· Telecommunication equipment (Terminal) · Measuring equipment
· Tooling machines · Computers)

If the use of the product in the above application areas is for equipment listed in paragraphs (2) or (3), please be sure to observe the precautions given in those respective paragraphs.

- (2) Appropriate measures, such as fail-safe design and redundant design considering the safety design of the overall system and equipment, should be taken to ensure reliability and safety when this product is used for equipment which demands high reliability and safety in function and precision, such as ;

(· Transportation control and safety equipment (aircraft, train, automobile etc.)
· Traffic signals · Gas leakage sensor breakers · Rescue and security equipment
· Other safety equipment)

- (3) Please do not use this product for equipment which require extremely high reliability and safety in function and precision, such as ;

(· Space equipment · Telecommunication equipment (for trunk lines)
· Nuclear power control equipment · Medical equipment)

- (4) Please contact and consult with a Sharp sales representative if there are any questions regarding interpretation of the above three paragraphs.

3. Please contact and consult with a Sharp sales representative for any questions about this product.

1. Application
This specification applies to the outline and characteristics of Silicon OPIC light detecting device Model No. GA1A1S202WP.
2. Outline
Refer to the attached drawing No. CY14103L02.
3. Ratings and characteristics
Refer to the attached sheet, page 5.
4. Reliability
Refer to the attached sheet, page 6.
5. Outgoing inspection
Refer to the attached sheet, page 7.
6. Supplement
 - (6-1) Circuit block diagram
Refer to the attached sheet, page 8.
 - (6-2) Packing
Refer to the attached sheet, attachment -2-1 to 2-4.
 - (6-3) This product is not designed against electromagnetic and ionized-particle irradiation.
 - (6-4) This product shall not contain the following materials.
Also, the following materials shall not be used in the production process for this product.
Materials for ODS : CFCs, Halon, Carbon tetrachloride
1,1,1-Trichloroethane (Methyl chloroform)
 - (6-5) Compliance with each regulation
 - 6.5.1 The RoHS directive(2002/95/EC)
This product complies with the RoHS directive(2002/95/EC).
Object substances: mercury, lead, cadmium, hexavalent chromium, Polybrominated biphenyls (PBB) and Polybrominated diphenyl ethers (PBDE)
 - 6.5.2 Content of six substances specified in Management Methods for Control of Pollution Caused by Electronic Information Products Regulation (Chinese : 电子信息产品污染控制管理办法).

| Category | Toxic and hazardous substances | | | | | |
|---------------------|--------------------------------|--------------|--------------|---|--------------------------------|---------------------------------------|
| | Lead (Pb) | Mercury (Hg) | Cadmium (Cd) | Hexavalent chromium (Cr ⁶⁺) | Polybrominated biphenyls (PBB) | Polybrominated diphenyl ethers (PBDE) |
| OPIC LIGHT DETECTOR | ✓ | ✓ | ✓ | ✓ | ✓ | ✓ |

✓ : indicates that the content of the toxic and hazardous substance in all the homogeneous materials of the part is below the concentration limit requirement as described in SJ/T 11363-2006 standard .

- (6-6) This product does not contain specific brominated flame retardants such as the PBB and PBDE .
- (6-7) Product mass (Piece): Approximately 3.5mg

REFERENCE

7. Notes

(7-1) By-pass capacitors

In order to stabilize power supply line, connect some by-pass capacitors of $0.01\mu\text{F}$ or more between Vcc and GND within 5mm from lead pins.

(7-2) Cleaning conditions :

Solvent cleaning : Solvent temperature : 45°C or less , Immersion time : 3 min or less

Ultrasonic cleaning : The effect to device by ultrasonic cleaning differs by cleaning bath size, ultrasonic power output, cleaning time, PCB size or device mounting condition etc.

Please test it in actual using condition and confirm that doesn't occur any defect before starting the ultrasonic cleaning.

The cleaning shall be carried out with solvent below.

Solvent : Ethyl alcohol, Methyl alcohol, Isopropyl alcohol

(7-3) Soldering

(7-3-1) Solder reflow

Please do two times or less soldering at the temperature and the time within the temperature profile in attached sheet-1.

(7-3-2) Soldering by hand

To solder onto terminals, please solder at 320°C for 3 seconds or less using soldering iron 50W or less.

Please be careful not to give the mechanical force to the package when soldering because it may cause the deformation or defect due to the plated connection.

(7-3-3) Case of other soldering

Other soldering methods such as dip soldering and VPS should not be used.

Please use (7-3-1) or (7-3-2).

REFERENCE

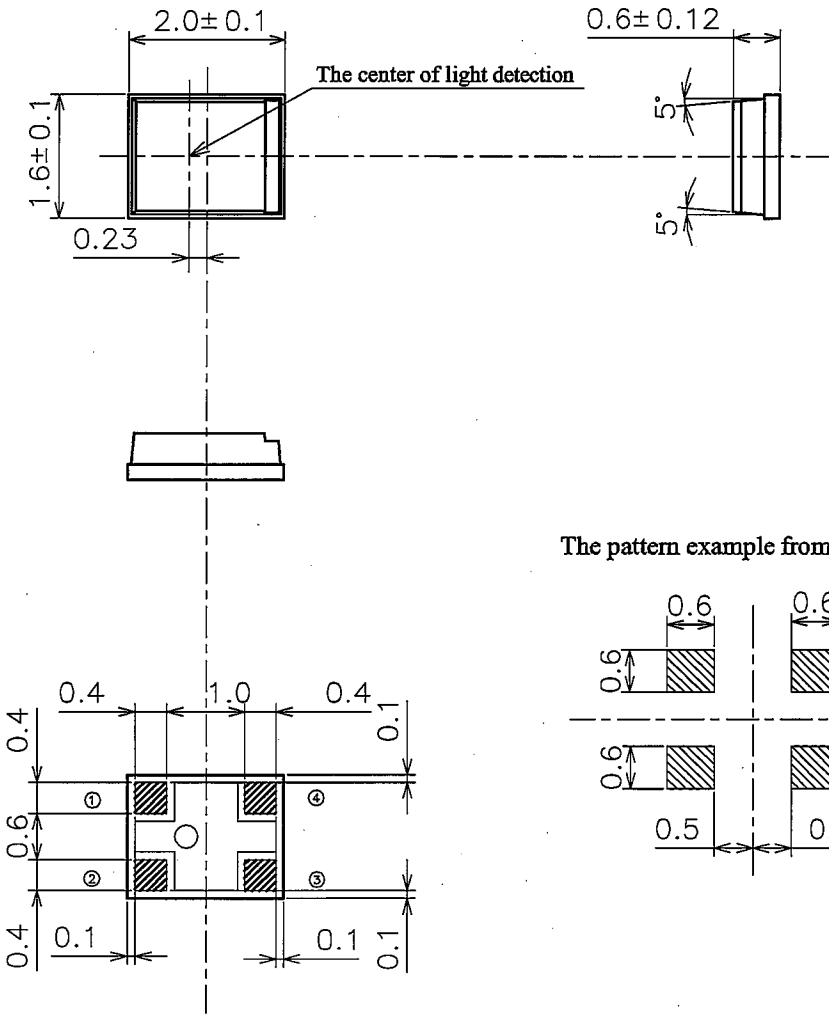

The pattern example from the view point of PCB

- 1) Unspecified tolerance shall be ± 0.2 mm.
- 2) area : Au plating

Pin arrangement

| | |
|---|-----|
| ① | GND |
| ② | GND |
| ③ | Io |
| ④ | Vcc |

| | | | | | | | | | | | | | |
|--------------|-----------------------|-----------------|-------------|--------------------|---|---|---|---|---|---|---|---|---|
| Scale | Material | Finish | Name | GA1A1S202WP | | | | | | | | | |
| 10 / 1 | | | | Outline Dimensions | | | | | | | | | |
| Unit | Package : Epoxy resin | Pin: Au plating | Drawing No. | C | Y | 1 | 4 | 1 | 0 | 3 | L | 0 | 2 |
| 1 = 1 / 1 mm | | | | | | | | | | | | | |

REFERENCE

3. Ratings and characteristics

3.1 Absolute maximum ratings

 $T_a = 25^\circ\text{C}$

| Parameter | Symbol | Rating | Unit |
|------------------------|-----------|--------------|------------------|
| Supply voltage | V_{cc} | -0.3 to +7.0 | V |
| Output current | I_o | 1 | mA |
| Operating temperature | T_{opr} | -40 to +85 | $^\circ\text{C}$ |
| Storage temperature | T_{stg} | -40 to +85 | $^\circ\text{C}$ |
| Soldering temperature* | T_{sol} | 250 | $^\circ\text{C}$ |

* Within 10s and two times (MAX) according to the attached reflow profile

3.2 Recommended operating conditions

 $(\text{Condition: } T_a = 0 \text{ to } 70^\circ\text{C})$

| Parameter | Symbol | MIN. | MAX. | Unit |
|----------------|----------|------|-------|------|
| Supply voltage | V_{cc} | 2.3 | 3.2 | V |
| Dynamic range | D | 3 | 55000 | lx |

3.3 Electro-optical characteristics

 $T_a = 25^\circ\text{C}, V_{cc} = 2.9\text{V}$

| Parameter | Symbol | Condition | MIN. | TYP. | MAX. | Unit |
|------------------------------|-------------|---|------|------|------|-----------------------|
| Supply current *1,*2 | I_{cc} | $E_v = 1000\text{lx}$ | 40 | 70 | 150 | μA |
| Output current 1 *1,*2 | I_{o1} | $E_v = 100\text{lx}$ | 16 | 20 | 24 | μA |
| Output current 2 *1,*2 | I_{o2} | $E_v = 1000\text{lx}$ | 27 | 30 | 33 | μA |
| Output current 3 | I_{o3} | $E_v = 0\text{lx}$ | - | - | 1 | μA |
| Temperature Coefficient | $\alpha 1$ | $T_a = -30^\circ\text{C to } +70^\circ\text{C},$ $E_v = 1000\text{lx}$ | - | - | 0.25 | $\% / ^\circ\text{C}$ |
| | $\alpha 2$ | $T_a = 0^\circ\text{C to } +50^\circ\text{C},$ $E_v = 1000\text{lx}$ | - | - | 0.2 | $\% / ^\circ\text{C}$ |
| Peak sensitivity | λ_p | - | - | 555 | - | nm |
| Rise time *3 | tr1 | $E_v = 100 \text{ to } 55000\text{lx}$ $R = 27\text{k}\Omega$ | - | - | 150 | μs |
| | tr2 | $E_v = 3 \text{ to } 55000\text{lx}$ $R = 27\text{k}\Omega$ | - | - | 5 | ms |
| Fall time *3 | tf1 | $E_v = 100 \text{ to } 55000\text{lx}$ $R = 27\text{k}\Omega$ | - | - | 150 | μs |
| | tf2 | $E_v = 3 \text{ to } 55000\text{lx}$ $R = 27\text{k}\Omega$ | - | - | 15 | ms |
| Output current difference *4 | ΔI | I_o (incandescent lamp $E_v = 100\text{lx}$) $-I_o$ (fluorescent lamp $E_v = 100\text{lx}$) *4 | -2 | - | 2 | μA |

*1: E_v : Illuminance by CIE standard light source A (tungsten lamp)

*2: Sensor output vs. illuminance is logarithmic.

$$I_o = 10 \times \log(E_v) \quad (\mu\text{A})$$

*3: E_v : Illuminance by white LED.

*4: White LED is used on mass production line instead of fluorescent lamp.

REFERENCE

4. Reliability

The reliability of products shall satisfy items listed below.

Confidence level : 90%

LTPD : 10 or 20

| Test Items | Test Conditions | Failure Judgment Criteria | Samples (n) |
|--------------------------------------|---|--|--------------|
| | | | Defective(C) |
| Temperature cycling | 1 cycle -40°C ↔ +85°C (30min) (30min) 20 cycles test | $I_{cc} < L \times 0.8$ $I_{cc} > U \times 1.2$ $I_{o1} < L \times 0.8$ $I_{o1} > U \times 1.2$ $I_{o2} < L \times 0.8$ $I_{o2} > U \times 1.2$ U: Upper specification limit L: Lower specification limit | n=22, C=0 |
| High temp. and high humidity storage | +60°C, 90%RH, 500h | | n=22, C=0 |
| High temp. storage | +85°C, 500h | | n=22, C=0 |
| Low temp. storage | -40°C, 500h | | n=22, C=0 |
| Operation test | $V_{CC}=3.2V$, $T_a=+25^\circ C$, $E_v=3000lx$ 500h | | n=22, C=0 |
| Mechanical shock | 1000m/s ² , 6ms, Half sine wave 3 times/±X, ±Y, ±Z direction | | n=11, C=0 |
| Variable frequency vibration | 100 to 2000 to 100Hz/Sweep for 4min 200m/s ² , 48min/X, Y, Z direction | | n=11, C=0 |
| Soldering heat | 250°C, 10 s, 2 times The temperature profile is according to the precautions for soldering (attachment-1). | | n=11, C=0 |

REFERENCE

5. Outgoing inspection

(1) Inspection lot

Inspection shall be carried out per each delivery lot.

(2) Inspection method

A single sampling plan, normal inspection level II based on ISO2859 shall be adopted.

| Parameter | Inspection items and test method | | | | AQL(%) | | |
|--|---|------------------------------|--|-------------------|--------|------|---------|
| Major defect | 1 | Disconnection, short | | | | 0.1 | |
| | 2 | Inverse polarity on terminal | | | | | |
| | 3 | Characteristics defect | | | | | |
| | | Parameter | Symbol | Judgment criteria | | | Unit |
| | | | | MIN. | MAX. | | |
| | | Supply current | Icc | 40 | 150 | | μA |
| | | Output current 1 | Io1 | 16 | 24 | | μA |
| Output current 2 | Io2 | 27 | 33 | μA | | | |
| Output current 3 | Io3 | - | 1 | μA | | | |
| Measurement conditions are described in 3.3. | | | | | | | |
| Minor defect | 1 | Appearance defect | | | | 0.25 | |
| | | Parameter | Judgment criteria | | | | |
| | | Crack | Visible crack irrespective of its position shall be defect. | | | | |
| | | Split, Chip, Scratch, Stain | One which affects the characteristics of paragraph 3.3. shall be defect. | | | | |
| Bubble, Foreign matter (One on resin surface which can wipe off shall not be applied.) | One which is more than 1.0mm ϕ or one which affects the characteristics of paragraph 3.3. , shall be defect. | | | | | | |

6. Supplement

(6-1) Circuit block diagram

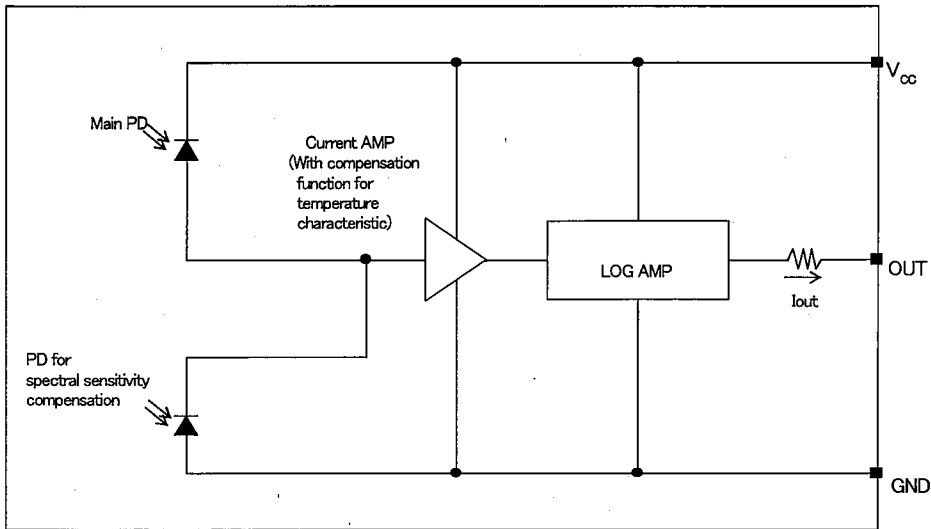

(6-2) Output Current Characteristic

Output Current Characteristics (TYP.)

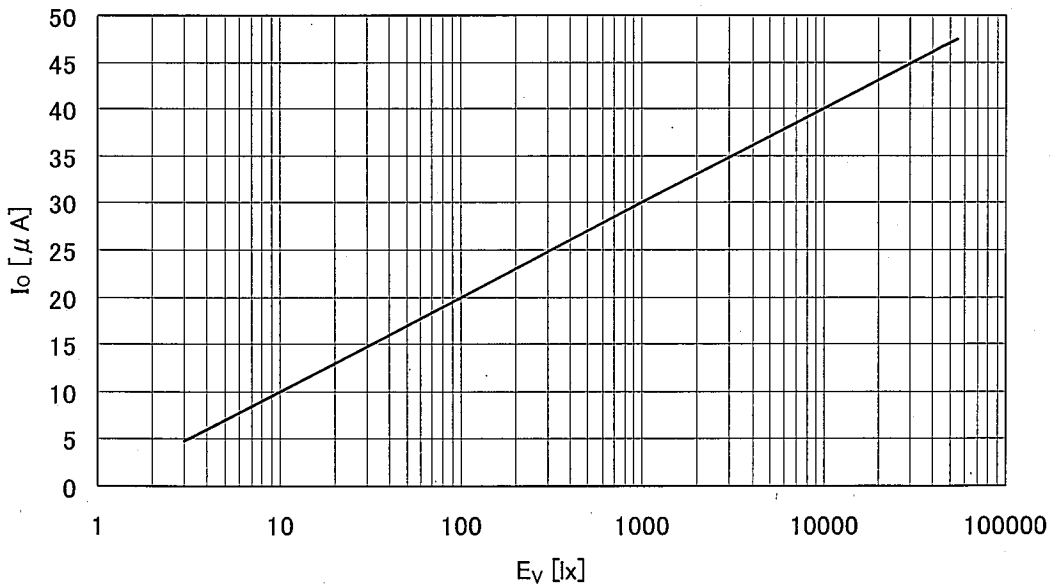

REFERENCE

(Attachment-1-1)

Precautions for Soldering GA1A1S202WP

1. In case, solder reflow

Please do two times or less soldering at the temperature and the time within the temperature profile as shown in the figure below.

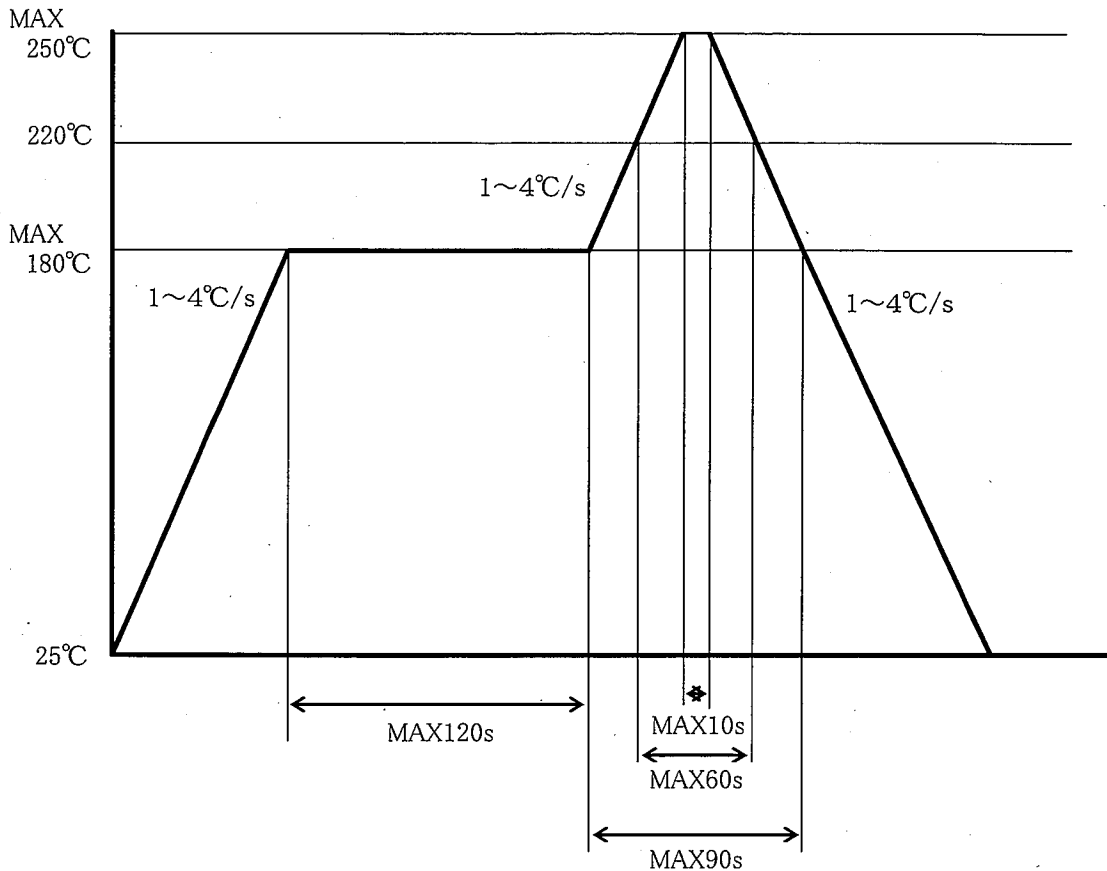

2. Other precautions

An infrared lamp used to heat up for soldering may cause a localized temperature rise in the resin.

So keep the package temperature within that specified in Item 1.

Please be careful not to give the mechanical force to the package when soldering because it may cause the deformation or defect due to the plated connection.

Even if within the temperature profile above, there is the possibility that the gold wire in package is broken in case that the deformation of PCB gives the affection to terminals.

Please use after confirming the conditions fully by actual solder reflow machine.

REFERENCE

(Attachment-1-2)

3. Storage and management after opening the package

3.1 Storage condition : Storage shall be in accordance with the below conditions.

Storage temp. : 5 to 30°C

Storage humidity : 70%RH or less

3.2 Treatment after opening the package

- (1) After opening the package, please mount at the conditions of humidity 60%RH or less and temperature 5 to 25°C within 3 days.
- (2) In case of long time storage after opening the package, please mount within 2 weeks at the conditions of (A) or (B).
 - (A) after resealing with desiccant in moisture-proof sack by sealer, keeping in the condition of humidity 70%RH or less and temperature 5 to 30°C
 - (B) keeping in the dry box (humidity 20% or less, temperature 5 to 25°C)

3.3 Baking before mounting

In case that it could not be carried out the above treatment, or the humidity indicator card turned pink when opening the package, it is able to mount by baking treatment. However baking treatment shall be limited only 1 time.

Recommended conditions : 125°C, 16 to 24 hours

Recommended conditions at the packaged condition by the reel : 65°C, 48 hours

- ※ In the case baking at the packaged condition, please hang the reel in the oven using the spindle through the center hall of the reel. Please do not put the reel across the oven.

(Attachment-2-1)

Package specifications (φ 180mm reel)

1. Application

This specification applies to the taping specifications and the relation items for the GA1A1S202WP.

2. Taping method

(2.1) Tape structure and Dimensions (Refer to the attached sheet-2-2)

The tape shall have a structure in which a cover tape is sealed heat-pressed on the carrier tape made by electrically conductive polycarbonate to protect against static electricity.

(2.2) Reel structure and Dimensions (Refer to the attached sheet-2-3)

The reel shall be made of plastic.

(2.3) Direction of product insertion (Refer to the attached sheet-2-3)

Product direction in carrier tape shall direct to the Io and Vcc terminal (= the part of the cutout of the package) at the hole side on the tape, shall direct to the terminal part of the product at the bottom side of the rectangle hole on the tape, shall direct to the detecting part at the upside of the rectangle hole on the tape.

(2-4) Inclusion correction

In case correcting inclusion failing products, these products can be cut out from the carrier tape and the cutting parts can be sealed. At this time, the products are not included at the same places.

3. Adhesiveness of cover tape

The exhalation force between carrier tape and cover tape shall be 0.1N to 1.0N for the angle from 160° to 180° .

4. Rolling method and quantity

Wind the tape back on the reel so that the cover tape will be outside the tape.

Attach more than 16cm of blank tape to the trailer and 40cm to the leader of the tape and fix the both ends with adhesive tape.

One reel shall contain 2000 pcs, but in the case products by failing to seal are cut out(refer to the 2-4), the number is less.

5. Marking

The outer packaging case shall be marked with following information.

* Model No. * Number of pieces delivered * Production date

6. Safety protection during shipping

There shall be no deformation of component or degradation of electrical characteristics due to shipping.

REFERENCE

(Attachment-2-2)

Tape structure and Dimensions

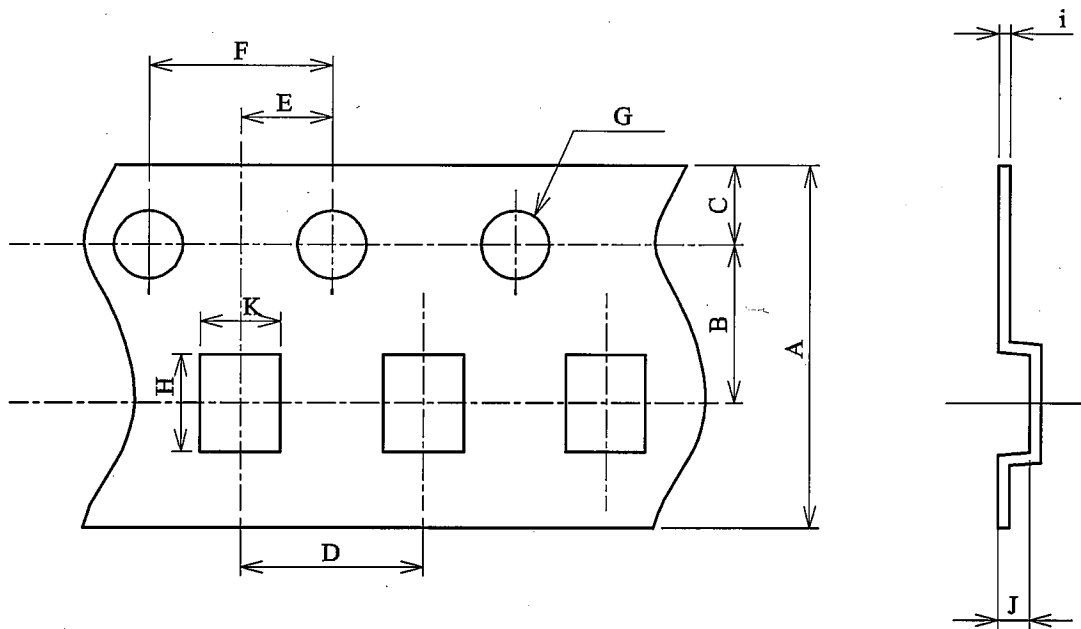

| Unit \ Symbol | A | B | C | D | E | F |
|---------------|---------------|---------------|-----------------|---------------|---------------|---------------|
| mm | 8.0 ± 0.1 | 3.5 ± 0.1 | 1.75 ± 0.10 | 4.0 ± 0.1 | 2.0 ± 0.1 | 4.0 ± 0.1 |

| Unit \ Symbol | G | H | i | J | K |
|---------------|---|-----------------|-----------------|-----------------|-----------------|
| mm | $\phi 1.5 \begin{smallmatrix} +0.1 \\ -0 \end{smallmatrix}$ | 2.12 ± 0.10 | 0.25 ± 0.10 | 0.70 ± 0.10 | 1.70 ± 0.10 |

(Attachment-2-3)

Reel structure and Dimensions

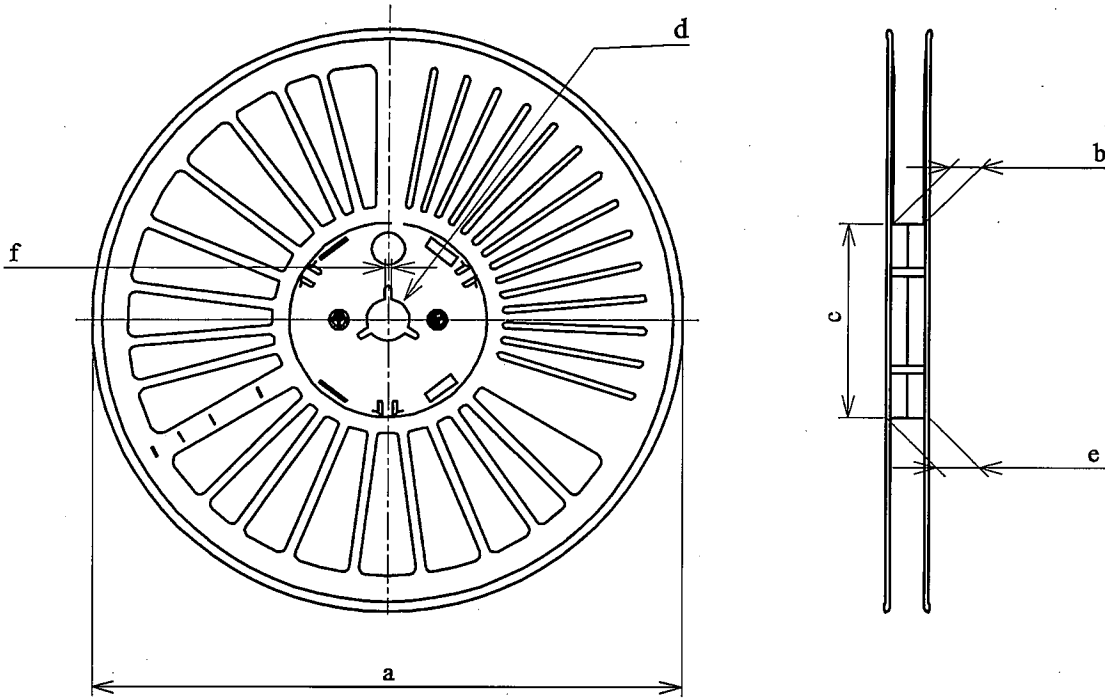

| Unit \ Symbol | a | b | c | d | e | f |
|---------------|----------------------|---------------|---------------------|---------------------|----------------|---------------|
| mm | $\phi 180.0 \pm 1.0$ | 9.5 ± 1.0 | $\phi 60.0 \pm 1.0$ | $\phi 13.0 \pm 0.2$ | 13.1 ± 1.0 | 2.0 ± 0.5 |

Direction of product insertion

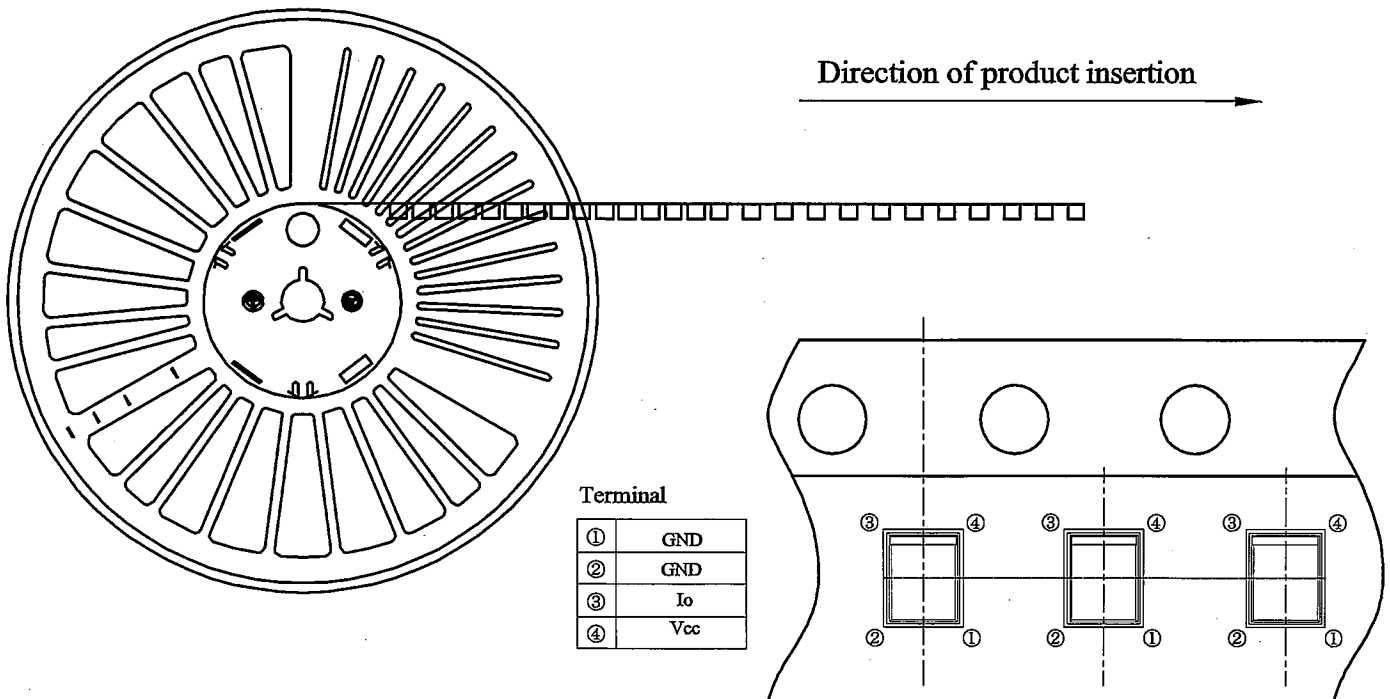

(Attachment-2-4)

Moisture-proof package specification (ϕ 180mm reel)

1. Application

This specification applies to the products which Sharp delivers to customer.

2. Packing specifications

2.1 Packaging material

| Name | Material | Quantity | Aim |
|-------------------------|-----------------------|----------------|--------------------------------------|
| Aluminum laminated bag | Aluminum polyethylene | Refer to 2.2 | Moisture-proof |
| Label | Paper(-made) | - | Indication of Model No. and Quantity |
| Humidity indicator card | Paper(-made) | 1 sheet / reel | Indication of Humidity |

2.2 Packaging method

- (1) Seal the aluminum laminated bag included the ruled tape-reel and humidity indicator card quantity.
- (2) Fill up the blank of label and paste on the bag.
- (3) Put the moisture-proof laminated bag in the ruled case

| Package shape | Product | Quantity | Moisture-proof sack Quantity |
|---------------------------|-----------|-----------------|------------------------------|
| Tape-reel (ϕ 180mm) | 1ch. type | 2000pcs. / reel | 1 reel / bag |

Minimum order Quantity : 1 reel / bag

- (4) Packing case is closed by craft tape and Model No., Quantity, and Inspection date are filled out.
(Quantity: 10,000pcs./case) *Except the case products by failing to seal are cut out.

3. Storage and management after opening the package

3.1 Storage condition : Storage shall be in accordance with the below conditions.

Storage temp. : 5 to 30°C

Storage humidity : 70%RH or less

3.2 Treatment after opening the package

- (1) After opening the package, please mount at the conditions of humidity 60%RH or less and temperature 5 to 25°C within 3 days.
- (2) In case of long time storage after opening the package, please mount within 2 weeks at the conditions of (A) or (B).
 - (A) after resealing with desiccant in moisture-proof sack by sealer, keeping in the condition of humidity 70%RH or less and temperature 5 to 30°C
 - (B) keeping in the dry box (humidity 20% or less, temperature 5 to 25°C)

3.3 Baking before mounting

In case that it could not be carried out the above treatment, or the humidity indicator card turned pink when opening the package, it is able to mount by baking treatment. However baking treatment shall be limited only 1 time.

Recommended conditions : 125°C, 16 to 24 hours

Recommended conditions at the packaged condition by the reel : 65°C, 48 hours

- ※ In the case baking at the packaged condition, please hang the reel in the oven using the spindle through the center hall of the reel. Please do not put the reel across the oven.

REFERENCE

4 Packaging

① Outer packing drawing

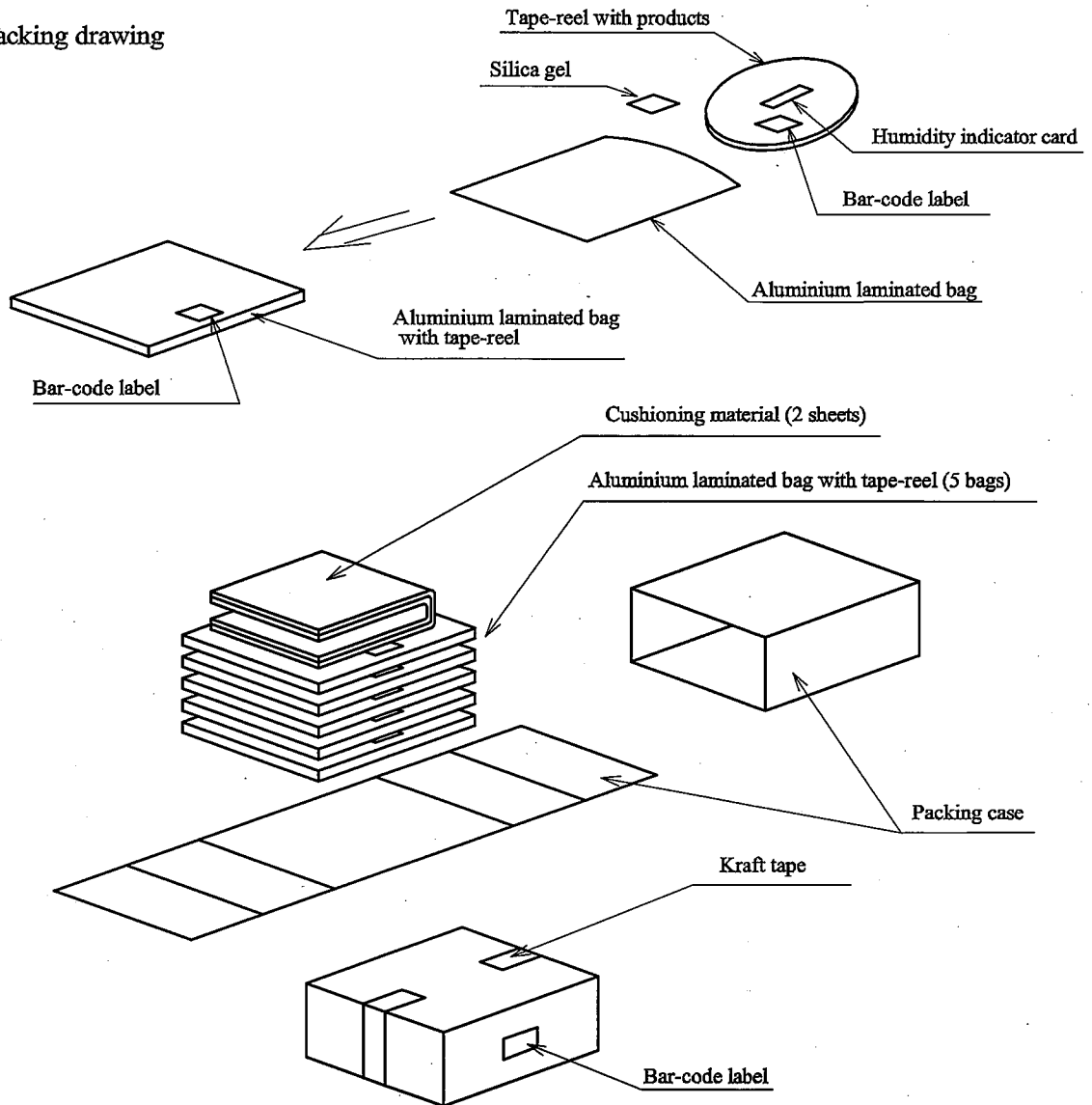

② Outer packing material: Packing case(Corrugated cardboard), Cushioning material (Urethane)
Aluminium laminated bag (Alumi-Polyethylene)

Humidity indicator card (paper), Label(paper), Silica gel, Kraft tape

③ Quantity: 10,000pcs./box

④ Indication: Model No., quantity and inspection date

⑤ Regular packaged mass: Approximately 600g

Opto Specification

Opto/EC Group



NORTH AMERICA

Sharp Microelectronics of the Americas
5700 NW Pacific Rim Blvd.
Camas, WA 98607, U.S.A.
Phone: (1) 360-834-8700
Fax: (1) 360-834-8903
www.sharpsma.com

TAIWAN

Sharp Electronic Components
(Taiwan) Corporation
8F-A, No. 16, Sec. 4, Nanking E. Rd.
Taipei, Taiwan, Republic of China
Phone: (886) 2-2577-7341
Fax: (886) 2-2577-7326/2-2577-7328

CHINA

Sharp Microelectronics of China
(Shanghai) Co., Ltd.
28 Xin Jin Qiao Road King Tower 16F
Pudong Shanghai, 201206 P.R. China
Phone: (86) 21-5854-7710/21-5834-6056
Fax: (86) 21-5854-4340/21-5834-6057
Head Office:
No. 360, Bashen Road,
Xin Development Bldg. 22
Waigaoqiao Free Trade Zone Shanghai
200131 P.R. China
Email: smc@china.global.sharp.co.jp

EUROPE

Sharp Microelectronics Europe
Division of Sharp Electronics (Europe) GmbH
Sonninstrasse 3
20097 Hamburg, Germany
Phone: 49 (0)180 507 35 07
Fax: (49) 40-2376-2232
www.sharpsme.com

SINGAPORE

Sharp Electronics (Singapore) PTE., Ltd.
438A, Alexandra Road, #05-01/02
Alexandra Technopark,
Singapore 119967
Phone: (65) 271-3566
Fax: (65) 271-3855

KOREA

Sharp Electronic Components
(Korea) Corporation
RM 501 Geosung B/D, 541
Dohwa-dong, Mapo-ku
Seoul 121-701, Korea
Phone: (82) 2-711-5813 ~ 8
Fax: (82) 2-711-5819

JAPAN

Sharp Corporation
Electronic Components & Devices
22-22 Nagaïke-cho, Abeno-Ku
Osaka 545-8522, Japan
Phone: (81) 6-6621-1221
Fax: (81) 6117-725300/6117-725301
www.sharp-world.com

HONG KONG

Sharp-Roxy (Hong Kong) Ltd.
Level 26, Tower 1, Kowloon Commerce Centre,
No. 51, Kwai Cheong Road, Kwai Chung,
New Territories, Hong Kong
Phone: (852) 28229311
Fax: (852) 28660779
www.sharp.com.hk
Shenzhen Representative Office:
Room 602-603, 6/F,
International Chamber of Commerce Tower,
168 Fuhua Rd. 3, CBD,
Futian District, Shenzhen 518048,
Guangdong, P.R. China
Phone: (86) 755-88313505
Fax: (86) 755-88313515

SPECIFICATIONS ARE SUBJECT TO CHANGE WITHOUT NOTICE.

Suggested applications (if any) are for standard use; See Important Restrictions for limitations on special applications. See Limited Warranty for SHARP's product warranty.

The Limited Warranty is in lieu, and exclusive of, all other warranties, express or implied.

ALL EXPRESS AND IMPLIED WARRANTIES, INCLUDING THE WARRANTIES OF MERCHANTABILITY, FITNESS FOR USE AND FITNESS FOR A PARTICULAR PURPOSE, ARE SPECIFICALLY EXCLUDED. In no event will SHARP be liable, or responsible in any way, for any incidental or consequential economic or property damage.

Mouser Electronics

Authorized Distributor

Click to View Pricing, Inventory, Delivery & Lifecycle Information:

[Sharp Microelectronics:](#)

[GA1A1S202WP](#)