

KMA36 MAGNETIC ENCODER IC

The KMA36 magnetic encoder IC from TE Connectivity (TE) is an excellent solution for reliable and precise measurement in innovative and rugged applications. Its Anisotropic Magnetoresistive (AMR) technology determines accurately and contactless the magnetic angle of an external magnet over 360° with resolution up to 15 bit.

The KMA36 offers a sleep reduced power mode over I²C. In addition, programmable parameters give users access to a wide range of configuration options to provide the maximum of freedom and functionalities.

Used both as a linear or a rotary position sensor, the KMA36 magnetic encoder IC has large air gap tolerance. The measurement is reliable over temperature ranges and insensitive to thermal stress. The maintenance-free operation and high bandwidth of this universal magnetic sensor make it a good choice for dynamic applications in harsh environments.

Features

- Small TSSOP Package
- Digital Output
- I²C Interface
- High Resolution up to 0.01°
- Rotational or Linear Measurement Mode
- AMR Technology

Applications

Precise rotary and linear position measurements for:

- Industrial and medical robotics and devices
- Potentiometer replacement
- Motion control, like transportation roller etc.
- Valve position in industrial valves
- Gauge readings (e.g. Bourdon tubes etc.)

Specifications

Operating power supply range of 3V to 5.5V	3.0 – 5.5V
Operating temperature	-25°C to +85°C
Average current	10 – 30 mA
Sleep current	1.5 mA
Data Update rate	24 – 720 Hz
I²C Clock rate (Standard I²C interface)	Up to 100 Kbit/s
Angle measurement	Contactless absolute 360° (180°)
I²C device address	Hardware configurable
Communication interface	Standard I ² C (100 kHz)
Digital Resolution	Up to 15 bit (0.01 degree)
Operation modes	Incremental Linear High accuracy Low power Sleep mode (with automatic wake-up over I ² C)
Additional features	Very low hysteresis, User programmable parameters, Programmable zero position
Environmental standards	RoHS, Reach

Pin Assignment

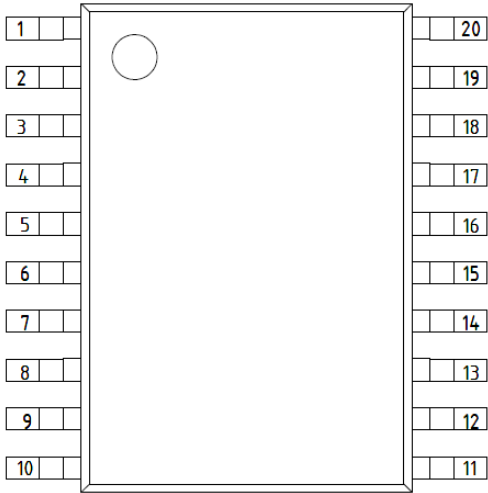

Pin No. KMA36 TSSOP	Symbol	Type	Description
1	A1	NC	Not connected
2	A0	I	Slave address config. pin
3	DVCC_SE	O	Drive pin to power sensor
4	SDA	I/O	Two-wire interface data pin
5	PWM	O	PWM output
6	SCL	I	Two-wire interface clock pin
7	GND_SE	S	Sensor supply ground pin
8	VCC_SE	S	Sensor power supply pin
9	NC	NC	Not connected
10	NC	NC	Not connected
11	NC	NC	Not connected
12	COILP	I	Coil power supply pin
13	COILN	I	Coil power supply pin
14	AREF	I	Asic analog reference
15	NC	NC	Not connected
16	GND_AS	S	Asic supply ground
17	NC	NC	Not connected
18	VCC_AS	S	Asic power supply
19	DCOILN	O	Drive pin to coil power supply
20	DCOILP	O	Drive pin to coil power supply

Figure 1: Pin assignment (TSSOP20)

Electrical Characteristics

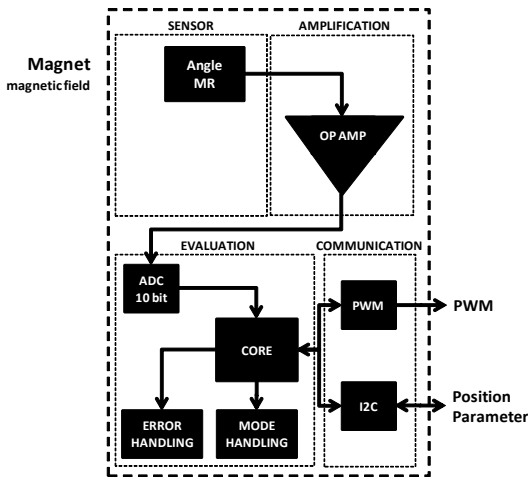

Figure 2: Functional block description

Unless otherwise specified, all voltages are referenced to the power ground supply VSS. Typical values are based on $T_{op}=25^{\circ}\text{C}$, $V_{CC} = 5\text{ V}$. They are given only as design guidelines and are not tested in production. Data based on characterization results, design simulation and/or technology characteristics are indicated in the table footnotes and are not tested in production.

Absolute maximum ratings are limiting values of permitted operation and should never be exceeded under the worst possible conditions either initially or consequently. If exceeded by even the smallest amount, instantaneous catastrophic failure can occur. And even if the device continues to operate satisfactorily, its life may be considerably shortened.

Absolute Maximum Ratings

CAUTION: Exceeding these values may destroy the product.

Symbol	Parameter	Condition	Min.	Typ.	Max.	Unit
T _{op}	Operating temperature		- 25		+ 85	°C
T _{sto}	Storage temperature		- 40		+ 85	°C
V _{cc}	Operating voltage		2.9		6.0	V
V _{in}	Input voltage on any Pin		-0.5		V _{cc} +0.5	V
I _{in}	DC Current through any I/O Pin				40	mA
I _{in}	DC Current through S Pin				200	mA
I _{in}	DC Current through any C Pin				60	mA

Table 1: Absolute maximum ratings

Operating Conditions

Symbol	Parameter	Condition	Min.	Typ.	Max.	Unit
T _{op}	Operating temperature		- 25		+ 85	°C
V _{cc}	Operating voltage		3		5.5	V
V _{in}	Input voltage on I/O pin		-0.3		V _{cc} +0.5	V
A _{Ref}	External Analog Reference ¹⁾		1.8	2.2	2.5	V
R _{AREF}	Analog Reference input resistance		-	32	-	kΩ

Table 2: Operating conditions

¹⁾ Apply 2.2V at AREF for best results

Please refer to the typical application section to know which external components should be connected.

AC/DC Characteristics

Symbol	Parameter	Condition	Min.	Typ.	Max.	Unit
I _{avg}	Average current ¹⁾	Except in sleep mode, V _{cc} = 5V	10		30	mA
I _{avg}	Average current ¹⁾	Except in sleep mode, V _{cc} = 3V	5		16	mA
I _{sleep}	Sleep current	V _{cc} = 5V V _{cc} = 3V		2 0.5		mA
V _{IL}	Input low voltage		-0.5		0.3 x V _{CC}	V
V _{IH}	Input high voltage		0.6 x V _{CC}		V _{CC} + 0.5	V
V _{OL}	Output low voltage	I _{OL} = 5 mA			0.6	V
V _{OH}	Output high voltage	I _{OH} = 5 mA	0.86 x V _{CC}			V

Table 3: AC/DC characteristics

¹⁾ Current measurement has been done with a standard circuit including a voltage divider on AREF.

System Parameters

Symbol	Parameter	Condition	Min.	Typ.	Max.	Unit
f_{data}	Update rate ^{1) 2)}		24		720	Hz
t_{start}	Starting time MCU			5		ms
t_{start}	Starting time PWM output			20		ms
α_{rd}	Resolution digital	$H_0=25$ kA/m, I ² C mode ³⁾		13 ⁵⁾	15	Bit
α_{ra}	Resolution analog	$H_0=25$ kA/m, PWM mode ³⁾		10		Bit
$\Delta\alpha$	Accuracy ^{4) 6)}	$H_0=25$ kA/m ³⁾ $T_{op}=25^\circ\text{C}$, I ² C mode, Oversampling=32		± 0.3	± 1	°
$\Delta\alpha_H$	Hysteresis error (Repeatability) ^{4) 6)}	$H_0=25$ kA/m ³⁾ $T_{op}=25^\circ\text{C}$, I ² C mode, Oversampling=32		± 0.1	± 0.25	°
V_{bwn}	Brown-out reset voltage			2.7		V
t_{bwn}	Brown-out reset pulse width			2		µs
H_0	Applied magnetic field		15	25	60	kA/m
R_{COIL}	Internal coil resistance		75	100	150	Ω
I_{COIL}	Internal coil current	$H_0=25$ kA/m	15	20	40	mA
f_{PWM}	PWM frequency			7.8		kHz

Table 4: System parameters

¹⁾ Maximum is measured in speed mode with minimum oversampling. Minimum is measured with maximum oversampling.

²⁾ When using the analog-output configuration then update rate is fixed at 88Hz

³⁾ System parameter were obtained with an applied magnetic field with field direction homogeneity better than 1%.

⁴⁾ Hysteresis and accuracy are depending nearly inversely proportional on the magnetic field strength.

The accuracy is defined as the max. angular difference between actual field angle and measured angle.

The hysteresis is defined as angular difference between left and right turn

⁵⁾ Using higher resolutions than 13 Bit may cause "missing bits" (occasionally skipped data values resulting in increased linearity error)

⁶⁾ At rotation speeds higher than 35000 °/min reduced accuracy and increased hysteresis error could be observed

Update rate

$$f_{data} = 1 / (1.4 \text{ msec} \times \text{oversampling} / \text{const})$$

SPD Bit	const
0	1
1	2

in [Hz]	I2C		Analog
	normal mode	speed mode	
2	357	714	88
4	179	357	
8	89	179	
32	22	45	

System Output

The system has two possible hardware output configurations: two-wire interface or analog output.

- **Analog Output**

The system has a Pulse Width Modulation unit with 10-bit resolution which can be easily coupled with a first order low-pass filter¹⁾ to generate an analog output between V_{ss} and V_{cc} corresponding to 0° and 360°. In this hardware configuration, all internal registers are loaded with initial values. No digital configuration is necessary; all available configurations can be set by changing the hardware setup²⁾ of the KMA36.

¹⁾ Please refer to the typical application section for further information.

²⁾ Please refer to the hardware configuration section for further information.

- **I²C (Digital Output)**

The KMA36 has an I²C Interface unit (two-wire interface, based on the standard I²C-bus specification defined by Philips Semiconductors) with an 8-bit data bus which can be easily used to retrieve measurement and configuration information. (Please refer to the two-wire interface section for details)

Two-Wire Interface

- Physical interface parameters

Symbol	Parameter	Condition	Min.	Typ.	Max.	Unit
B_{rt}	Clock rate		1	50	100	Kbit/s
A_L	Address length			7		bit
A_s	Address ¹⁾			0x59		Hex

Table 5: Physical interface parameters

1) Please refer to the hardware configuration section to determine how to configure other addresses.

- Timing parameters

Symbol	Parameter	Condition	Min.	Typ.	Max.	Unit
$t_{SU:STA}$	Start setup time		4.7			μ s
$t_{HD:STA}$	Start hold time		4.0			μ s
$t_{SU:STO}$	Stop setup time		4.0			μ s
t_{HIGH}	Clock high time		4.0		50	μ s
t_{LOW}	Clock low time		4.7			μ s
t_r	Rise time				1	μ s
t_f	Fall time				0.3	μ s
$t_{SU:DAT}$	Data input setup time		0.25			μ s
t_{BUF}	Bus free time		4.7			μ s

Table 6: Start, stop and data timing parameters

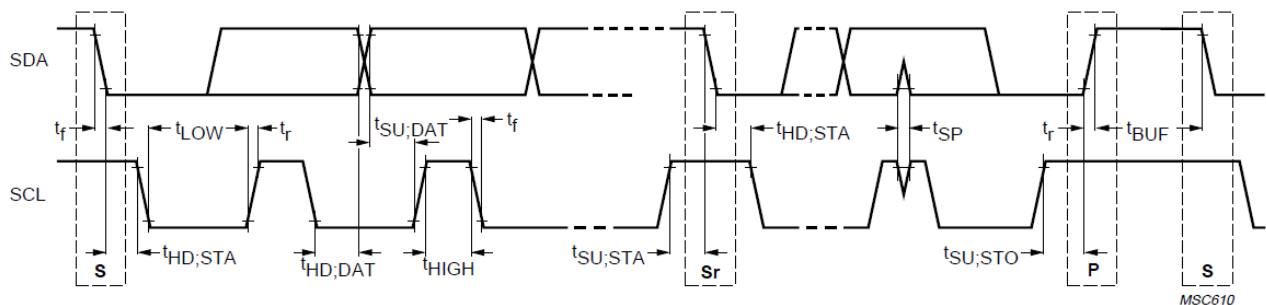

Figure 3: Timing definitions²⁾

²⁾ Please refer to the standard I²C-bus specification defined by Philips Semiconductors for further information.

• **Registers (Overview)**

The KMA36 contains the following I/O registers:

Registers of the KMA36			
Register	Size	Read/Write	Function
KCONF	8 bit	R/W	Configuration bits
KRES	16 bit	R/W	Resolution
MA	16 bit	R	Magnetic angle
ILC	32 bit	R	Incremental Counter

Table 7: Registers of the KMA36

• **I²C Bus**

The KMA36 is always operating as a pure slave.

• **I²C Reading data**

It is possible to read up to ten bytes as described in the following figure.

TWI - Read data										
Byte	0	1	2	3	4	5	6	7	8	9
	MA0	MA1	ILC0	ILC1	ILC2	ILC3	KCONF	KRESL	KRESH	CSSEND
Read/Write	R	R	R	R	R	R	R	R	R	R
Initial value	0x00	0x00	0x00	0x00	0x00	0x00	0x03	0x00	0x04	

Byte 0:1 - MA1:0: Magnetic angle
Unsigned integer giving the magnetic angle in degree with the configured resolution

Byte 2:5 - ILC3:0: Incremental linear counter
Signed long giving the incremental linear counter in degree with the configured resolution.

Byte 6 - KCONF: Configuration register
Unsigned char giving the configuration register value.

Byte 8:7 - KRES: Resolution register
Contains the desired resolution.

Byte 9 - CSSEND: Checksum
Send data (Low-Byte of sum of Byte[0..9])

Table 8: Read data

• **I²C Writing data (general)**

The KMA36 can be controlled using two internal registers. The configuration (KCONF) is an 8-bit register and the resolution (KRES) is a 16-bit register. To write the 16-bit register (KRES) through the two-wire interface with an 8-bit data bus, it is necessary to send the high byte first and then the low byte.

To change the KMA configuration, four bytes should be sent through the two-wire 8-bit data bus. The first three bytes correspond to the configuration and resolution registers. The last byte contains an 8-Bit Cyclic Redundancy Check (CRC) value which can be calculated as described in the example.

After writing via I²C the KMA36 needs 60ms + time of 2 measurements (with new configuration) to process to data (worst case at 22Hz update rate = 151ms). Initiating any I²C communication within this period may cause unpredictable behavior.

TWI - Send data				
Byte	0	1	2	3
	KCONF	KRESH	KRESL	KCS
Read/Write	W	W	W	W
Initial value	-	-	-	-

Byte 0: KCONF: Configuration register
Contains the desired system configuration.

Byte 1:2 - KRES: Resolution register
Contains the desired resolution.

Byte 3 - KCS: Checksum
Contains the checksum.

Table 9: Send data

Example

	KCONF	KRESH	KRESL	KCS
data	0x03	0x7F	0xFF	0x7F

$$\boxed{\text{KCS}} = 0xFF - (\text{KCONF} + \text{KRESH} + \text{KRESL}) + 0x01$$

$$\boxed{\text{KCS}} = 0xFF - (0x03 + 0x7F + 0xFF) + 0x01 = 0x7F$$

Table 10: CS Example

• **KCONF (Configuration register)**

The configuration register is used to control and monitor the status and modes of the system:

KCONF - Configuration register

Bit	7	6	5	4	3	2	1	0
	SLP	-	LIN	CNT	PWR	SPD	OVCS1	OVSC0
Read/Write	W	R/W	R/W	R/W	R/W	R/W	R/W	R/W
Initial value	0	0	0	0	0	0	1	0

Bit 7 - SLP: Sleep mode

Writing this bit to one enables the sleep mode. This bit will be always set to zero by hardware.

Bit 5 - LIN: Mode

Writing this bit to one disables the rotational mode and enables the linear mode.

Bit 4 - CNT: Mode

Writing this bit to one enables the incremental counter mode. By writing it to zero, the counter mode is turned off and reset

Bit 3 - PWR: Low power mode

Writing this bit to one enables the low power mode.

Bit 2 - SPD: Speed mode

Writing this bit to one enables the fast speed mode.

Bit 1:0 - OVCS1:0: Oversampling

These bits determine the accuracy of the angle evaluation.

Table 11: KCONF – Configuration Register

- **Rotational measurement** used to measure the angle of a rotating magnet disc centered above the magnetic sensor center of the KMA36. ¹⁾
- **Linear measurement** used to measure the linear movement of the KMA36 along a magnetic pole strip with 5mm pole length. A lookup table is used for internal error correction ¹⁾
- **Sleep mode** used to power down the KMA36. Wake up is initiated by I²C communication

¹⁾ Please refer to the arrangement section.

• **SLP-Bit (KCONF register)**

Writing a “1” to this Bit will activate the sleep mode. The KMA36 will power down to sleep mode. To wake up the KMA36 please follow this procedure:

- Initiate a I²C read (minimum 1 byte) on any I²C address (The KMA36 will wake up temporarily)
- Wait 10...15 ms
- Initiate a I²C read (minimum 1 byte) on the I²C address of the KMA36 (The KMA36 will keep awake and start a new measurement)

• **LIN-Bit (KCONF register)**

Writing a “1” to this Bit will activate the linear measurement mode. This mode is used to measure the linear movement of the KMA36 along a magnetic pole strip with 5mm pole length. A lookup table is used for internal error correction. Please refer to the arrangement section.

Writing a “0” to this Bit will activate the rotational measurement mode. This mode is used to measure the angle of a rotating magnet disc centered above the magnetic sensor center of the KMA36. Please refer to the arrangement section.

• **CNT-Bit (KCONF register)**

In addition, there is an incremental counter implemented, which can be enabled by writing a one to the CNT-Bit in the KCONF register.

• **PWR-Bit (KCONF register)**

The current consumption can be reduced with the low power mode accessible through the PWR bit. In low power mode, only 180° measurements are possible.

• **SPD-Bit (KCONF register)**

The measurement update rate can be increased by activating the fast mode with SPD bit. In fast mode measurement accuracy is reduced.

Update rate

$$f_{data} = 1 / (1.4 \text{ msec} \times \text{oversampling} / \text{const})$$

SPD Bit	const
0	1
1	2

Table 12: Update rate

• **OVCS-Bits (KCONF register)**

To increase the measurement accuracy, it is possible to configure the oversampling rate by using the OVSCx bits. Please notice that a higher accuracy leads to a reduction of the update rate (Please refer to the Update rate table)

OVS1	OVS0	Oversampling
0	0	2
0	1	4
1	0	8
1	1	32

Table 13: OVSC - Oversampling

• **KRES (Resolution register)**

The resolution can be set to any decimal value between 1 and 32768. Any other value would lead to unexpected system behavior.

KRES - Resolution Register

Bit	15	14	13	12	11	10	9	8
KRESH	KRES15	KRES14	KRES13	KRES12	KRES11	KRES10	KRES9	KRES8
KRESL	KRES7	KRES6	KRES5	KRES4	KRES3	KRES2	KRES1	KRES0
Bit	7	6	5	4	3	2	1	0
Read/Write	W	W	W	W	W	W	W	W
	W	W	W	W	W	W	W	W
Initial value	0	1	1	1	1	1	1	1
	1	1	1	1	1	1	1	1

Bit 15:0 KRES15:0:
Resolution

Table 14: KRES - Resolution Register

For example, a resolution of decimal 360 (0x00168) leads to rotational data in steps of 1 degree. A resolution of decimal 3600 (0x0E10) results in steps of 0.1°.

Hardware Configuration

The hardware configuration depends on the desired output: two-wire interface or (analog) PWM output. In both modes, it is not allowed to left pin A0 floating / unconnected. In two-wire interface configuration, the slave address of the system can be configured by connecting A0 and another pin as described in following table.

Address	Connection	
0x59	A0	4,7K to GND
0x5A	A0	4,7K to DCOILP
0x5B	A0	4,7K to DCOILN
0x5C	A0	4,7K to DVCC_SE
0x5D	A0	4,7K to VCC

Table 15: TWI / I²C Slave address configuration

In analog mode, the rotation direction can be configured by connecting DVCC_SE and a power supply pin. The user zero reference angle calibration can be activated by connecting A0 and COILP. When the user zero reference angle calibration is active, the next evaluated magnetic angle will be set as the new zero reference angle. The user selectable output voltage for the zero-reference angle can be configured by connecting A0 in series with a 4,7k ohm resistor and a port pin. The percentage indicated is relative to the power supply value Vcc and is defined at the zero-reference angle position.

ANALOG - Rotation direction configuration

Direction	Connection	
CW	DVCC_SE	VCC
CCW	DVCC_SE	4,7K to GND

ANALOG - User selectable output for zero reference

Percent	Connection	
0%	A0	4,7K to VCC
10%	A0	4,7K to DVCC_SE
25%	A0	4,7K to DCOILN
50%	A0	4,7K to GND

ANALOG - Zero reference angle user calibration

Status	Connection	
Active	A0	COILP
Inactive	A0	-

Table 16: Analog-Mode configuration

Typical Application

Electrical circuit

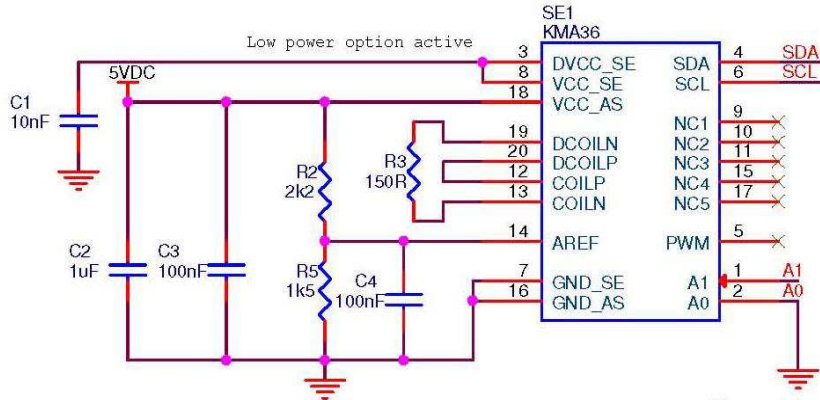

Figure 4: Typical circuit with two-wire interface

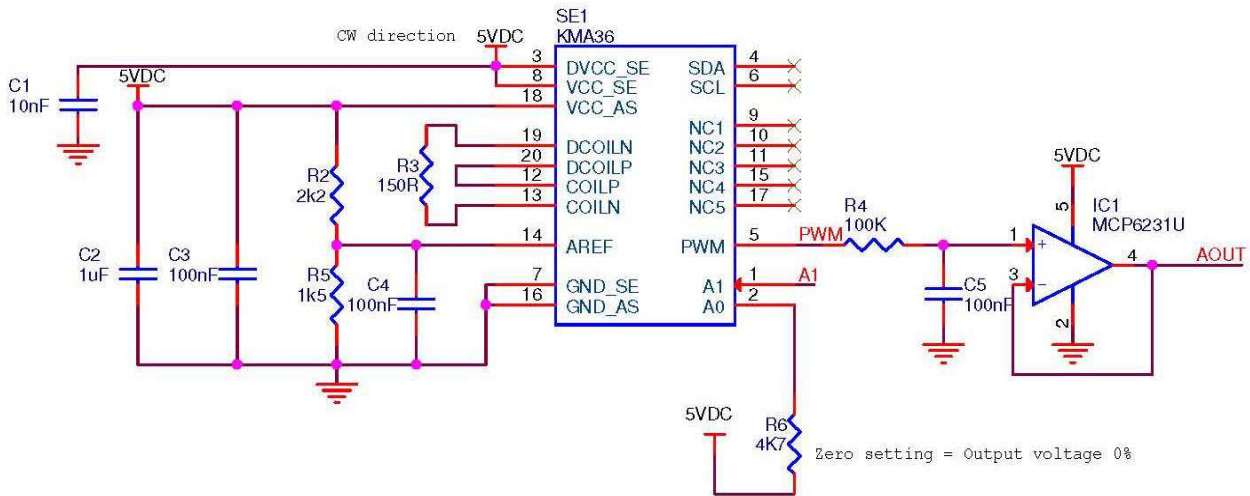

Figure 5: Typical circuit with analog interface

Arrangement

Due to the magneto resistive technology which senses the magnetic field direction in the sensor plane, it is advised to mount the magnet disc centered above the sensor center. Please refer to the magnets and scales section for more information about the magnetic center position of the KMA36. The magnetic scale should be placed perpendicularly to the KMA36 as depicted in the following figure rather in the middle along the width of the scale. For best results the KMA36 should be as close as possible to the magnet.

Recommended rotational setup (for best results)



Pay attention to the magnetic center of the KMA36

Digital signal and absolute error

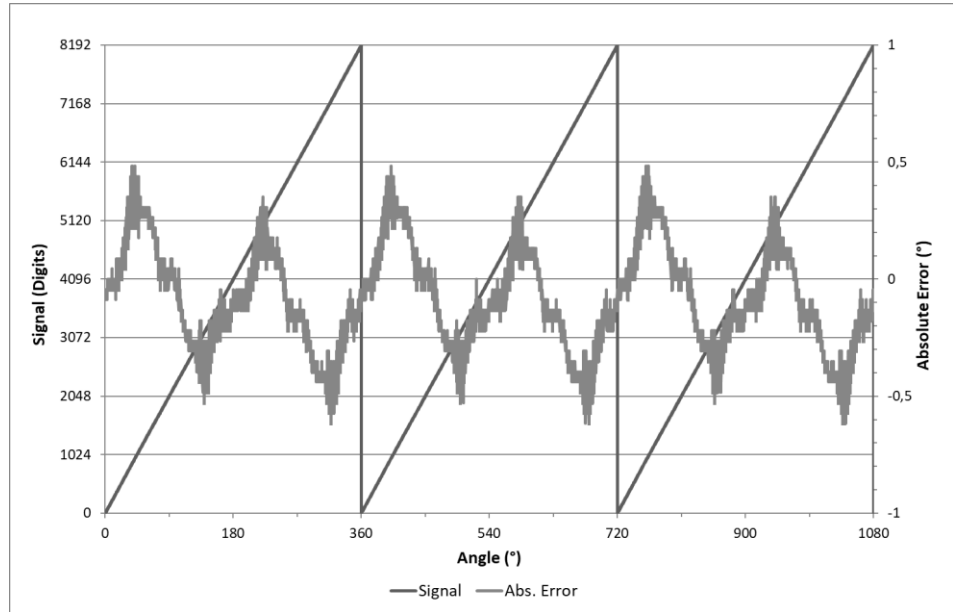

Rotational mode, Bit LIN = 0

Recommended linear setup



use magnetic pole strip with 5mm pole length for best results

Digital signal and absolute error

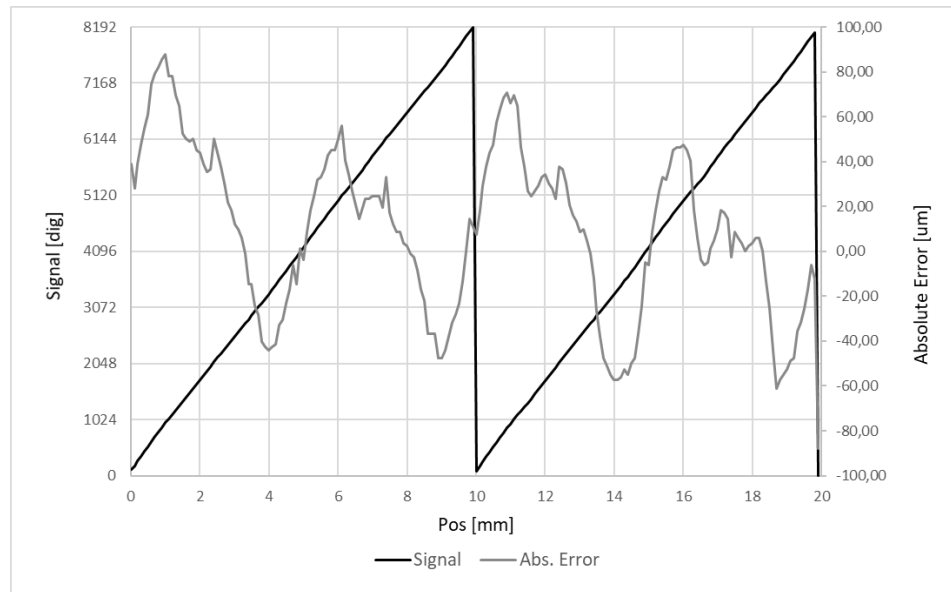

Linear mode, Bit LIN = 1

Figure 6: Typical application set ups

Magnets and Scales

Rotational Mode

The KMA36 can be used with a magnet, preferably of disc or square shape or a magnet scale with pole pitch 5mm.

For development purposes, TESS offers a magnet disc made of plastic bonded Nd-Fe-B magnetic material which provides a homogenous magnetic field with sufficient magnetic field strength for typical application with the KMA36. The following table describes typical magnets parameters. Please refer to the website <http://www.magnetfabrik.de> (article number 67.044-1) and its application note section for more information.

Symbol	Parameter	Condition	Min.	Typ.	Max.	Unit
\varnothing	Diameter	Neofer 48/60p only		14		mm
T	Thickness	Neofer 48/60p only		2.5		mm
B_r	Magnetic field strength	Neofer 48/60p only		540		mT
T_{op}	Operating temperature	Neofer 48/60p only			150	°C

Table 17a: Typical disc-magnet specification

Linear Mode

The linear mode of the KMA36 is designed for a magnetic scale with pole pitch 5mm. A magnetic scale is made of a magnetic ferrite elastomer bonded on a steel support which guarantees mechanical stability. The steel support is made of a stainless steel alloy that provides no loss of magnetic field strength. TE offers a standard scale with the following parameters for development purpose:

Symbol	Parameter	Condition	Min.	Typ.	Max.	Unit
L_T	Length			<= 1		m
L_P	Pole length			5		mm
W	Width			10		mm
T	Thickness			1.3		mm
Δp	Accuracy			40		μm/m
T_{op}	Operating temperature		-40		100	°C

Table 17b: Typical TESS magnet-scale specification

The correct magnet dimensions and assembly geometry depend on the specific arrangement of the application and are part of the specification of the entire system.

Package Drawing

TSSOP

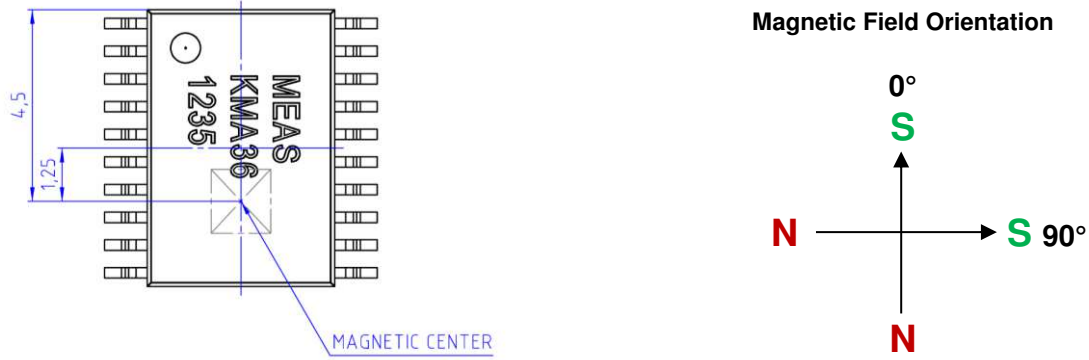

Figure 7: TSSOP20 Package drawing (magnetic center & orientation of magnetic field direction)

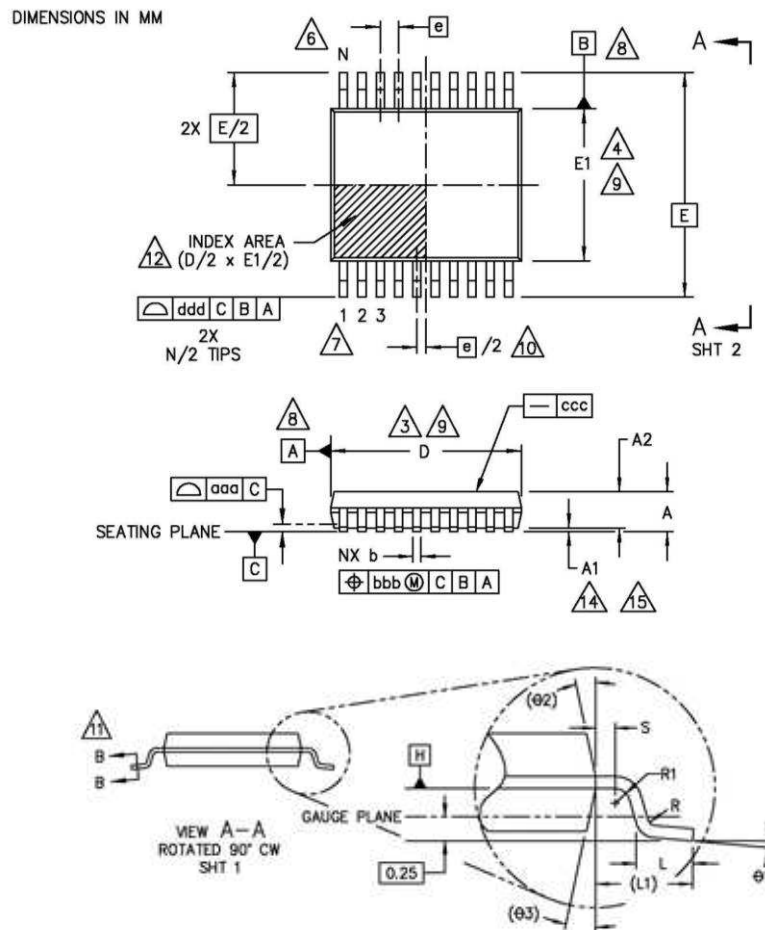

Figure 8: TSSOP20 Package drawing

Dimensions

COMMON DIMENSIONS (MILLIMETERS)			
Symbol	Min.	Typ.	Max.
A	-	-	1.20
A1	0.05	-	0.15
A2	0.80	1.00	1.05
b	0.19	-	0.30
D	6.40	6.50	6.60
E	-	6.40	-
E1	4.30	4.40	4.50
e	-	0.65	-
L	0.45	0.60	0.75
N	-	20	-
R	0.09	-	-
S	0.20	-	-
∅1	0°	-	8°

Table 18: TSSOP20 common dimensions

Ordering Information

Description	Package	Part Number
KMA36 TSSOP20	Tubes	G-MRMO-031
KMA36 TSSOP20	TnR 500pcs	23370000-01

Table 19: Ordering codes

NORTH AMERICA
Tel +1 800 522 6752
customercare.hmpt@te.com

EUROPE
Tel +31 73 624 6999
customercare.dtm@te.com

ASIA
Tel +86 0400 820 6015
customercare.shzn@te.com

te.com/sensorsolutions

Measurement Specialties (MEAS), TE Connectivity, TE Connectivity (logo) and EVERY CONNECTION COUNTS are trademarks. All other logos, products and/or company names referred to herein might be trademarks of their respective owners.

The information given herein, including drawings, illustrations and schematics which are intended for illustration purposes only, is believed to be reliable. However, TE Connectivity makes no warranties as to its accuracy or completeness and disclaims any liability in connection with its use. TE Connectivity's obligations shall only be as set forth in TE Connectivity's Standard Terms and Conditions of Sale for this product and in no case will TE Connectivity be liable for any incidental, indirect or consequential damages arising out of the sale, resale, use or misuse of the product. Users of TE Connectivity products should make their own evaluation to determine the suitability of each such product for the specific application.

© 2019 TE Connectivity Ltd. family of companies All Rights Reserved.