

Helping Customers Innovate, Improve & Grow



### Description

The FX-500 is a complete crystal-based frequency translator used in communications applications where low jitter is paramount. Performance advantages include superior jitter performance, high output frequencies and small package size. Advanced custom ASIC technology results in a highly robust, reliable and predictable device. The device is packaged in a 6 pin J-Lead ceramic package with a hermetic seam welded lid.

### Features

- Complete Frequency Translator to 80.00 MHz
- 3.3 Volt or 5.0 Volt Supply
- Capable of locking to an 8kHz pulse/ BITS clock
- Tri-State Output allows board test
- Lock Detect
- J-lead Ceramic Package
- Advanced Custom ASIC Technology
- Absolute Pull Range Performance to  $\pm 100$  ppm
- CMOS output
- Commercial or Industrial Temperature Range
- EIA Compatible Tape and Reel Packaging
- RoHS Compliant \*

### Applications

- Frequency Translation, Clock Smoothing
- Telecom - SONET/SDH/ATM
- Datacom - DSLAM, DSLAR, Access Nodes
- Cable Modem Head End
- Base Station - GSM, CDMA



\* ( Except parts with Sn-Pb Solder Coated Option )

### Block Diagram

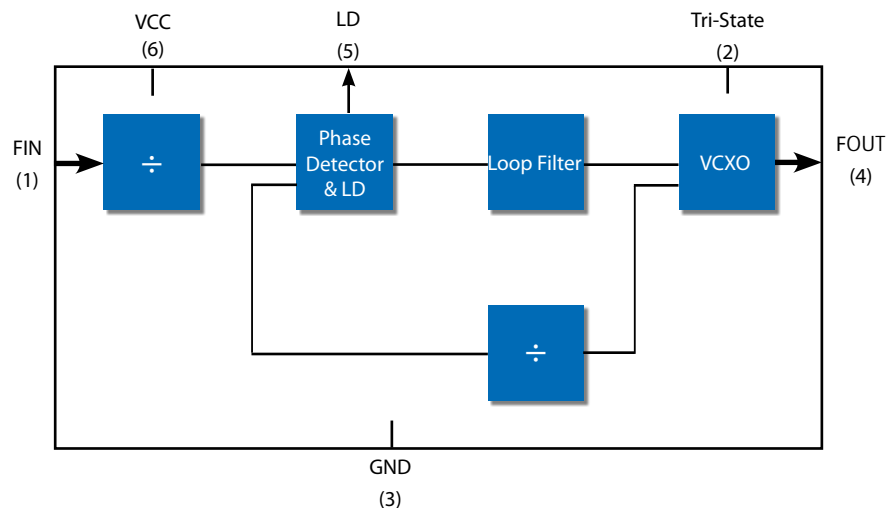

Figure 1. Functional block diagram

# Performance Specifications

**Table 1. Electrical Performance**

Parameter	Symbol	Min	Typical	Maximum	Units
Frequency					
Input Frequency	$F_{IN}$	0.001		80.00	MHz
Capture Range (Ordering Option)	APR	$\pm 50$		$\pm 100$	ppm
Output Frequency	$F_{OUT}$	1.0		80.00	MHz
Supply <sup>1</sup>					
Voltage (Ordering Option)	$V_{DD}$	3.0	3.3	3.6	V
Current (No Load)	$V_{DD}$	4.5	5.0	5.5	V
	$I_{DD}$			40	mA
Input Signal					
Input Low Level Voltage	$V_{IL}$			$0.3 \cdot V_{DD}$	V
Input High Level Voltage	$V_{IH}$	$0.7 \cdot V_{DD}$			V
Pulse Width		6			ns
Output <sup>2</sup>					
Output High Level Voltage	$V_{OH}$	$0.9 \cdot V_{DD}$			V
Output Low Level Voltage	$V_{OL}$			$0.1 \cdot V_{DD}$	V
Rise Time	$t_R$		1.8	3.0	ns
Fall Time	$t_F$		1.8	3.0	ns
Duty Cycle <sup>3</sup>	D				%
≤ 60 MHz		45		55	%
> 60MHz		40		60	%
Leakage Current of Input	$I_C$	-1		1	μA
Loop Bandwidth (-3dB), 8kHz input	BW		10		Hz
Jitter, 8kHz to 77.76MHz					
rms			4.7		ps
p-p			44		ps
			0.003		UI

1. A 0.1 μF low frequency tantalum bypass capacitor in parallel with a 0.01 μF high frequency ceramic capacitor is recommended.
2. Figure 2 defines the waveform parameters. Figure 3 illustrates the standard test conditions under which these parameters are specified and tested.
3. Duty cycle is defined as (on time÷period), with  $V_S = V_{DD}/2$ , per figure 2. Duty cycle is measured with a 15pf load per figure 3.
4. Other frequencies may be available, please contact factory.

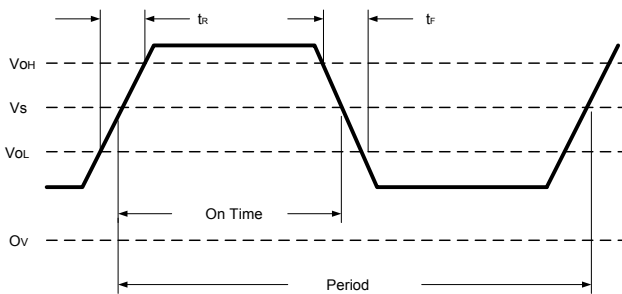

FIGURE 2. Output Waveform

Figure 2. Output Waveform

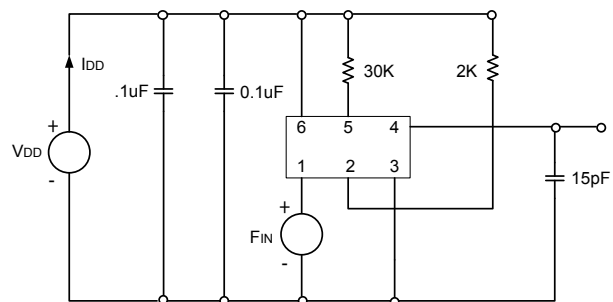

Figure 3. Output Test Conditions (25 ± 5°C)

## Absolute Maximum Ratings

Stresses in excess of the absolute maximum ratings can permanently damage the device. Functional operation is not implied at these or any other conditions in excess of conditions represented in the operational sections of this data sheet. Exposure to the maximum ratings for the extended periods may adversely affect device reliability.

Table 2. Absolute Maximum Ratings

Parameter	Symbol	Ratings	Unit
Power Supply	$V_{DD}$	7	V
Storage Temperature	$T_{STR}$	-55 to +125	°C

## Reliability

The FX-500 is capable of meeting the following qualification tests

Table 3. Environmental Compliance

Parameter	Conditions
Mechanical Shock	MIL-STD-883, M2002/TEST A
Mechanical Vibration	MIL-STD-883, M2007/TEST A
Lead Solderability	MIL-STD-883, M2003
Gross and Fine Leak	MIL-STD-883, M1014

## Handling Precautions

Although ESD protection circuitry has been designed into the the FX-500, proper precautions should be taken when handling and mounting. VI employs a human body model and a charged-device model (CDM) for ESD susceptibility testing and design protection evaluation. ESD thresholds are dependent on the circuit parameters used to define the model. Although no industry wide standard has been adopted for the CDM, a standard HBM of resistance=1.5Kohms and capacitance = 100pF is widely used and therefore can be used for comparison purposes.

Table 4. Predicted ESD Ratings

Model	Minimum	Conditions
Human Body Model	1000 V	MIL-STD 883, Method 3015
Charged Device Model	1000 V	JEDEC, JESD22-C101

Table 5. Reflow Profile (IPC/JEDEC J-STD-020C)

Parameter	Symbol	Value
PreHeat Time	$t_s$	60 sec Min, 180 sec Max
Ramp Up	$R_{UP}$	3 °C/sec Max
Time Above 217 °C	$t_L$	60 sec Min, 150 sec Max
Time To Peak Temperature	$t_{AMB-P}$	480 sec Max
Time At 260 °C	$t_p$	20 sec Min, 40 sec Max
Ramp Down	$R_{DN}$	6 °C/sec Max

The device has been qualified to meet the JEDEC standard for Pb-Free assembly. The temperatures and time intervals listed are based on the Pb-Free small body requirements. The temperatures refer to the topside of the package, measured on the package body surface. The FX-500 device is hermetically sealed so an aqueous wash is not an issue.

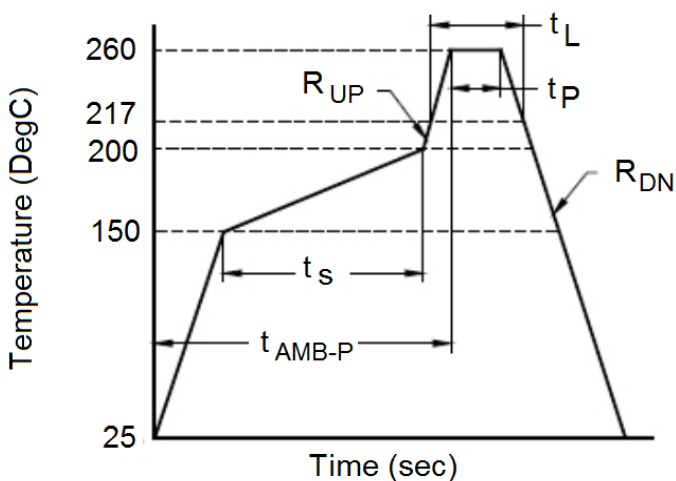

Figure 4. Suggested IR Profile

Table 6. Tape and Reel Information

Tape Dimensions (mm)					Reel Dimensions (mm)							
W	F	Po	P1	Do	A	B	C	D	N	W1	W2	#/Reel
24.00	11.50	4.00	12.00	1.50	330.20	2.03	12.70	23.11	101.60	24.64	29.84	1000

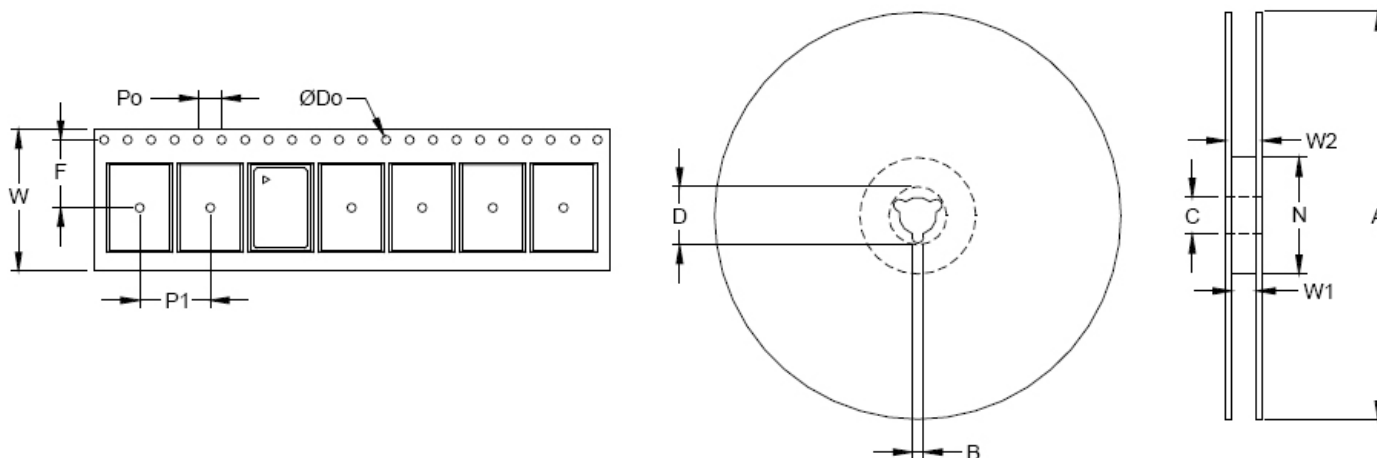

Figure 5. Tape and Reel

# Outline Drawing

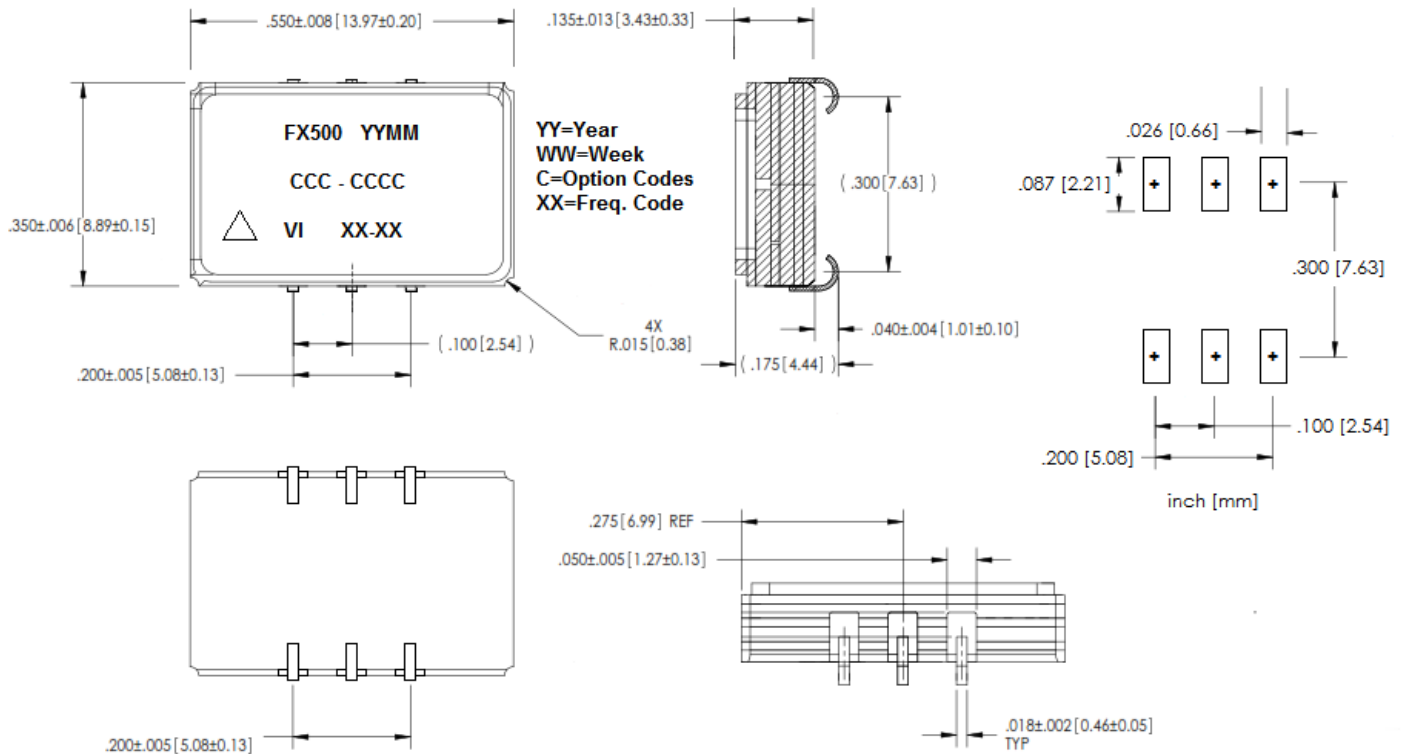

Figure 6. Outline Drawing and Pad Layout

Table 7. Pin Functions		
Pin #	Symbol	Function
1	$f_{IN}$	Input Frequency
2	Tri-State <sup>1</sup>	Logic Low = Output Disable Logic High = Output Enable
3	GND	Case and Electrical Ground
4	$f_o$	Output Frequency
5	LD <sup>2</sup>	Lock Detect
6	$V_{DD}$	Power Supply Voltage

1. Tristate is driven to logic high or logic low; there is no internal pull up or pull down resistor.
2. LD is an open collector output requiring a 30k ohm pull-up resistor to VDD. LD output is logic high under locked condition, logic low for no input at  $f_{IN}$ , and for "out-of-lock" condition LD transitions between logic low and logic high at the phase detector

## Ordering Information

**Table 8. Standard Frequencies (MHz)**

0.0010	A1	1.0000	BB	9.2160	CH	19.6990	DK	32.7680	H3	49.1520	J7
0.0020	AR	1.0240	B2	9.7200	C8	19.7190	DH	33.0000	H7	49.4080	J2
0.0032	AG	1.2150	BU	9.7500	CE	19.9219	ED	33.3330	HC	50.0000	JD
0.0040	A2	1.2288	BK	9.8304	C1	20.0000	E2	34.3680	H6	50.0480	KD
0.0080	A3	1.2500	BG	10.0000	C4	20.1416	E3	34.5600	HB	51.2000	LL
0.0095	AU	1.3333	BF	10.2300	DP	20.4800	E4	36.8640	HG	51.8400	J4
0.0100	A6	1.5000	BE	10.2400	DM	20.5444	EF	37.0560	H4	52.0000	JP
0.0156	AL	1.5360	BV	10.4143	DV	20.7135	E1	37.1250	H9	53.3300	JU
0.0157	AD	1.5440	B3	10.4582	DU	20.8286	EB	37.5000	HK	54.7460	JL
0.0158	AC	1.9200	B1	10.4872	DN	20.8286	EG	38.8800	H5	55.0000	JX
0.0160	A4	2.0000	B8	10.9490	DG	20.9165	EH	39.0625	HH	60.0000	JR
0.0240	BX	2.0480	B4	10.9500	DJ	21.0051	EJ	39.3216	HD	61.3800	KY
0.0250	BR	2.3040	BD	11.1840	DF	22.0000	E9	39.8438	HJ	61.4400	J5
0.0320	BW	2.4576	BJ	12.2880	D8	22.1048	EK	40.0000	JF	62.2080	J8
0.0400	AP	2.5000	BM	12.3077	DY	22.2171	E5	40.2831	KK	62.5000	J9
0.0441	AA	2.5575	B9	12.3520	D1	22.5792	E8	40.9600	J1	62.9145	LE
0.0480	AB	3.0880	B6	12.8000	D2	24.0000	EC	41.0889	KM	63.3600	JJ
0.0481	AV	3.2400	BL	13.0000	D3	24.5760	E6	41.6571	KP	63.8976	JN
0.0500	BT	3.2500	BC	13.5000	DT	24.7040	E7	41.8329	KT	64.0000	JT
0.0640	A5	3.3750	BH	14.8352	DL	25.0000	F7	42.0000	JB	64.1520	JH
0.0800	A9	3.8400	B7	15.0000	D4	25.1658	F8	42.0102	KV	65.5360	J6
0.1000	AH	4.0000	BN	15.0336	DR	25.6000	F6	42.5000	JC	66.0000	JA
0.1280	AX	4.0960	B5	15.3600	DW	25.9200	F2	42.6600	JZ	70.0000	KB
0.2430	A8	5.0000	C6	16.0000	D9	26.0000	F3	44.2095	KX	70.6560	KC
0.2560	AM	5.1200	CD	16.3840	D5	27.0000	F4	44.4343	LF	71.6100	KF
0.3200	AW	6.1440	CG	17.1840	DE	27.6480	FB	44.6218	JW	73.7280	K8
0.3840	AY	6.2914	CC	18.4320	D7	28.7040	F1	44.7360	J3	74.1250	K1
0.4000	AF	6.2915	CF	18.5280	DC	29.4912	F5	44.9280	JE	74.1758	KA
0.4800	AK	6.3120	C7	18.7500	EE	29.5000	F9	45.1584	JG	74.2500	K7
0.5000	BP	6.4800	C2	19.2000	DD	30.0000	HE	45.8240	JM	75.0000	KH
0.5120	AJ	6.7500	CB	19.3927	DX	30.7200	H1	46.0379	LG	76.8000	K4
0.6555	AE	7.6800	C9	19.4400	D6	30.8800	HF	46.7200	JK	77.7600	K2
0.7720	AT	7.7760	C5	19.5313	DZ	31.2500	H8	46.8750	JY	80.0000	K9
0.9600	A7	8.1920	C3	19.6608	DB	32.0000	H2	48.0000	JV		

*Note 1: Other frequencies are available upon request, please contact VI for details*

*SS is code for non-standard frequencies, list the frequency after the part number.*

*Note 2: Not all combinations are possible.*

*Note 3: Output frequency must be equal to or greater than the input frequency. The ratio of  $f_o/f_{in}$  must be an integer. Also, the output frequency must be equal to greater than 100 kHz.*

## Ordering Information

# FX-500-E A E-K N N N-XX-XX

### Product Family

FX: Frequency Translator

### Package

500: 9.0 x 14 x 4.5 mm

### Input

D: 5.0 Vdc  $\pm$ 10%

E: 3.3 Vdc  $\pm$ 10%

### Output

A: CMOS

### Operating Temperature

E: -40 to 85 °C

T: 0 to 70 °C

### Absolute Pull Range

K:  $\pm$  50 ppm

P:  $\pm$  80 ppm

S:  $\pm$  100 ppm

**Output Frequency**  
(See Above)

**Input Frequency**  
(See Above)

### Performance Options

N: Standard

A: Improved Phase Noise

### Loop Filter BW

N: Internal Loop Filter

### Lead Finish

N: 6 pin gold plated

S: 6 pin with solder coated leads \*

Note:

\* Leads are hot solder-dipped with 63/37 SnPb eutectic solder.

Not all combinations will be available - contact factory to determine the optimum configuration for your application.

## For Additional Information, Please Contact

### USA:

Vectron International  
267 Lowell Road, Unit 102  
Hudson, NH 03051  
Tel: 1.888.328.7661  
Fax: 1.888.329.8328

### Europe:

Vectron International  
Landstrasse, D-74924  
Neckarbischofsheim, Germany  
Tel: +49 (0) 3328.4784.17  
Fax: +49 (0) 3328.4784.30

### Asia:

Vectron International  
68 Yin Cheng Road(C), 22nd Floor  
One LuJiaZui  
Pudong, Shanghai 200120, China  
Tel: 86.21.6194.6886  
Fax: 86.21.6194.6699

### Disclaimer

Vectron International reserves the right to make changes to the product(s) and or information contained herein without notice. No liability is assumed as a result of their use or application. No rights under any patent accompany the sale of any such product(s) or information.