

Low- R_{ON} , Low-Voltage SPST Analog Switch

FSA1156, FSA1157

Description

The FSA1156 and FSA1157 are high-performance Single-Pole / Single-Throw (SPST) analog switches. The devices feature ultra-low R_{ON} of 0.75 Ω (typical) and operate over a wide V_{CC} range of 1.65 V to 5.5 V. The devices are fabricated with sub-micron CMOS technology to achieve fast switching speeds. The select input is TTL-level compatible. The FSA1156 has normally open operation; the FSA1157 has normally closed operation.

Features

- Maximum 0.95 Ω R_{ON} for 4.5 V Supply at 25°C
- 0.3 Ω Maximum R_{ON} Flatness at 4.5 V Supply
- Broad V_{CC} Operating Range: 1.65 V to 5.5 V
- Fast Turn-On and Turn-Off Time
- Over-Voltage Tolerant, TTL-Compatible Control Input
- Available in Space-saving 6-lead, MicroPak™ and SC70 Packages
- These Devices are Pb-Free and are RoHS Compliant

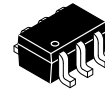

SC-88 (SC-70 6 Lead), 1.25x2
 CASE 419AD



SIP6 1.45X1.0
 CASE 127EB

MARKING DIAGRAM

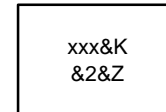

- xxx = Specific Device Code (156, EH, or 157)
- &K = 2-Digits Lot Run Traceability Code
- &2 = 2-Digit Date Code
- &Z = Assembly Plant Code

ORDERING INFORMATION

See detailed ordering and shipping information on page 2 of this data sheet.

FSA1156, FSA1157

ORDERING INFORMATION

Part Number	Top Mark	Package	Shipping†
FSA1156P6X	156	SC-88 (SC-70 6 Lead), 1.25x2 (Pb-Free)	3000 / Tape & Reel
FSA1156L6X	EH	SIP6 1.45X1.0 (Pb-Free)	5000 / Tape & Reel
FSA1157P6X	157	SC-88 (SC-70 6 Lead), 1.25x2 (Pb-Free)	3000 / Tape & Reel

†For information on tape and reel specifications, including part orientation and tape sizes, please refer to our Tape and Reel Packaging Specifications Brochure, BRD8011/D.

PIN CONFIGURATIONS

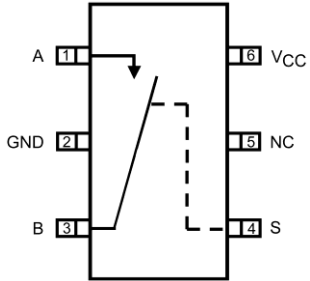

Figure 1. FSA1156 SC70 Top View (Normally Open)

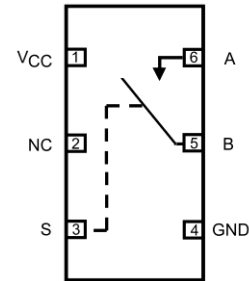

Figure 2. FSA1156 MicroPak Top Through View (Normally Open)

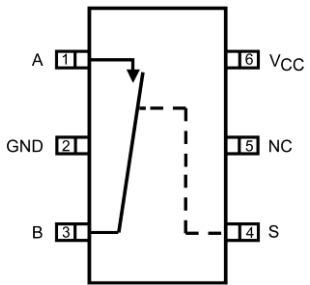

Figure 3. FSA1156 SC70 Top View (Normally Open)

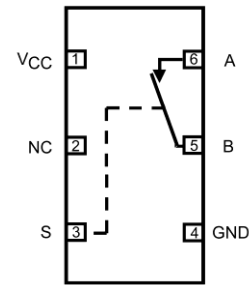

Figure 4. FSA1157 MicroPak Top Through View (Normally Open)

PIN DEFINITIONS

Pin# SC70	Pin# Micropak	Name	Description
1	6	A	Data Ports
2	4	GND	Ground
3	5	B	Data Ports
4	3	S	Control Input
5	2	NC	No Connect
6	1	VCC	Supply Voltage

TRUTH TABLE

Control Input (S)	FSA1156	FSA1157
Low	OFF	ON
High	ON	OFF

FSA1156, FSA1157

ABSOLUTE MAXIMUM RATINGS

Symbol	Parameter	Min	Max	Unit	
V _{CC}	Supply Voltage	-0.5	6.0	V	
V _{SW}	Switch Voltage (Note 1)	-0.5	V _{CC} + 0.5	V	
V _{IN}	Input Voltage (Note 1)	-0.5	6.0	V	
I _{IK}	Input Diode Current		-50	mA	
I _{SW}	Switch Current		200	mA	
I _{SWPEAK}	Peak Switch Current (Pulse at 1 ms Duration, < 10% Duty Cycle)		400	mA	
P _D	Power Dissipation at 85°C, SC70 Package		180	mW	
T _{STG}	Storage Temperature Range	-65	+150	°C	
T _J	Maximum Junction Temperature		+150	°C	
T _L	Lead Temperature (Soldering, 10 seconds)		+260	°C	
ESD	Electrostatic Discharge Capability	Human Body Model, JESD22-A114		8000	V

Stresses exceeding those listed in the Maximum Ratings table may damage the device. If any of these limits are exceeded, device functionality should not be assumed, damage may occur and reliability may be affected.

1. Input and output negative ratings may be exceeded if input and output diode current ratings are observed.

RECOMMENDED OPERATING CONDITIONS

Symbol	Parameter	Min	Max	Unit
V _{CC}	Supply Voltage	1.65	5.50	V
V _{CNTRL}	Control Input Voltage (Note 2)	0	V _{CC}	V
V _{SW}	Switch Input Voltage	0	V _{CC}	V
T _A	Operating Temperature	-40	+85	°C
θ _{JA}	Thermal Resistance in Still Air, SC70 Package		350	°C/W

Functional operation above the stresses listed in the Recommended Operating Ranges is not implied. Extended exposure to stresses beyond the Recommended Operating Ranges limits may affect device reliability.

2. Control input must be held HIGH or LOW and it must not float.

FSA1156, FSA1157

DC ELECTRICAL CHARACTERISTICS (Typical values are at 25°C unless otherwise specified.)

Symbol	Parameter	Conditions	V _{CC} (V)	Ambient Temperature (T _A)					Units
				+25°C			-40 to +85°C		
				Min.	Typ.	Max.	Min.	Max.	
V _{IH}	Input Voltage High		2.7 to 3.6				2.0		V
			4.5 to 5.5				2.4		
V _{IL}	Input Voltage Low		2.7 to 3.6					0.6	V
			4.5 to 5.5					0.8	
I _{IN}	Control Input Leakage	V _{IN} = 0 V to V _{CC}	2.7 to 3.6				-1.0	1.0	μA
			4.5 to 5.5				-1.0	1.0	
I _{NO(OFF)} , I _{NC(OFF)}	Off Leakage Current	A = 1 V, 4.5 V, B = 4.5 V, 1 V	5.5	-2		2	20	20	nA
I _{A(ON)}	On Leakage Current	A = 1 V, 4.5 V, B = 1 V, 4.5 V, or Floating	5.5	-4		4	-40	40	nA
R _{ON}	Switch On Resistance (Note 3)	I _{OUT} = 100 mA, B = 1.5 V	2.7		1.4	2.1		2.5	Ω
		I _{OUT} = 100 mA, B = 3.5 V	4.5		0.75	0.90		1.00	
R _{FLAT(ON)}	On Resistance Flatness (Note 4)	I _{OUT} = 100 mA, B ₀ = 0 V, 0.75 V, 1.5 V	2.7		0.6				Ω
		I _{OUT} = 100 mA, B ₀ = 0 V, 1 V, 2 V	4.5		0.1	0.2		0.3	
I _{CC}	Quiescent Supply Current	V _{IN} = 0 V or V _{CC} , I _{OUT} = 0 V	3.6		0.1	0.5		1.0	μA
			5.5		0.1	0.5		1.0	

3. On resistance is determined by the voltage drop between the A and B pins at the indicated current through the switch.

4. Flatness is defined as the difference between the maximum and minimum value of on resistance over the specified range of conditions.

AC ELECTRICAL CHARACTERISTICS (Typical values are at 25°C unless otherwise specified.)

Symbol	Parameter	Conditions	V _{CC} (V)	Ambient Temperature (T _A)					Units	Figure
				+25°C			-40 to +85°C			
				Min.	Typ.	Max.	Min.	Max.		
t _{ON}	Turn-On Time	B = 1.5 V, R _L = 50 Ω, C _L = 35 pF	2.7 to 3.6		30	40		45	ns	Figure 7
		B = 3.0 V, R _L = 50 Ω, C _L = 35 pF	4.5 to 5.5		15	20		25		
t _{OFF}	Turn-Off Time	B = 1.5 V, R _L = 50 Ω, C _L = 35 pF	2.7 to 3.6		25	35		45	ns	Figure 7
		B = 3.0 V, R _L = 50 Ω, C _L = 35 pF	4.5 to 5.5		22	30		40		
Q	Charge Injection	C _L = 1.0 nF, V _{GE} = 0 V, R _{GEN} = 0 Ω	2.7 to 3.6		10				pC	Figure 8
			4.5 to 5.5		20					
OIRR	Off Isolation	f = 1 MHz, R _L = 50 Ω	2.7 to 3.6		-65				dB	Figure 9
			4.5 to 5.5		-65					
BW	-3db Bandwidth	R _L = 50 Ω	2.7 to 3.6		300				MHz	Figure 10
			4.5 to 5.5		300					
THD	Total Harmonic Distortion	R _L = 600 Ω, V _{IN} = 0.5 V _{PP} , f = 20 Hz to 20 kHz	2.7 to 3.6		0.001				%	Figure 11
			4.5 to 5.5		0.001					

FSA1156, FSA1157

CAPACITANCE

Symbol	Parameter	Conditions	V _{CC} (V)	Ambient Temperature +25°C			Units	Figure
				Min.	Typ.	Max.		
C _{IN}	Control Pin Input Capacitance	f = 1 MHz	0.0		3		pF	Figure 12
C _{OFF}	B Port Off Capacitance	f = 1 MHz	4.5		20		pF	Figure 12
C _{ON}	On Capacitance	f = 1 MHz	4.5		65		pF	Figure 12

FSA1156, FSA1157

TYPICAL PERFORMANCE CHARACTERISTICS

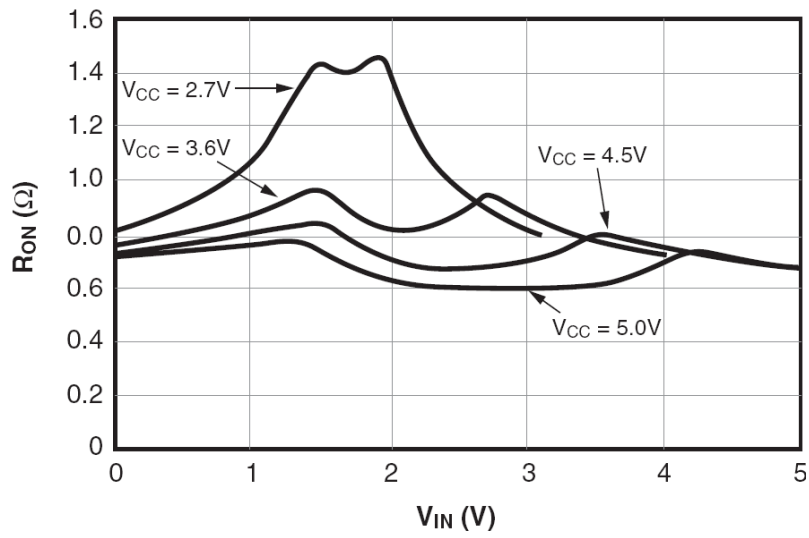

Figure 5. On Resistance vs. Input Voltage, Over Supply Voltage, $T_A = 25^\circ\text{C}$

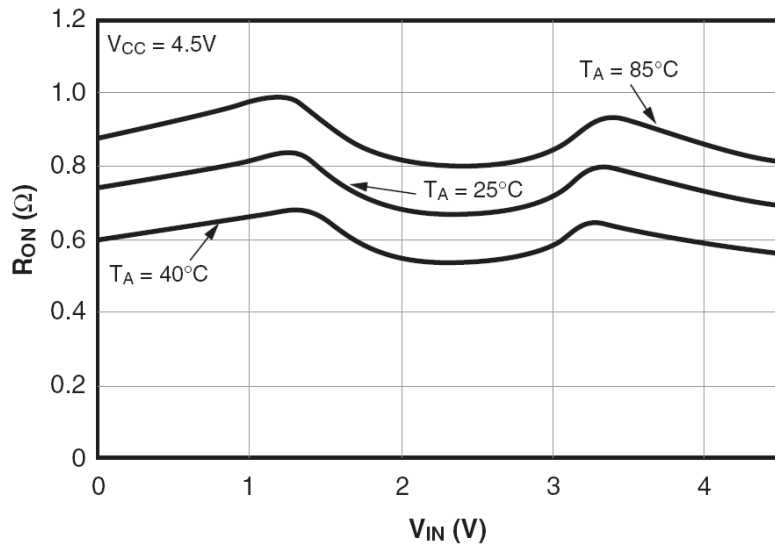
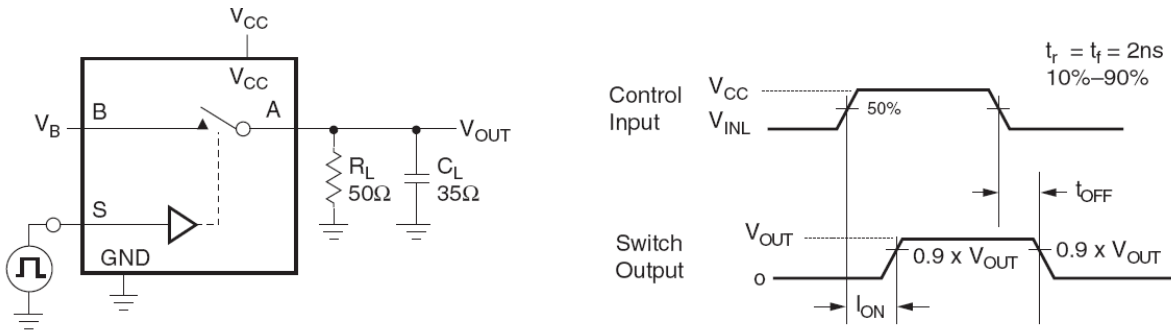

Figure 6. On Resistance vs. Input Voltage, Over Temperature

AC LOADINGS AND WAVEFORMS



C_L Includes Fixture and Stray Capacitance

Logic Input Waveforms Inverted for Switches that have the Opposite Logic Sense

Figure 7. Turn On / Off Timing

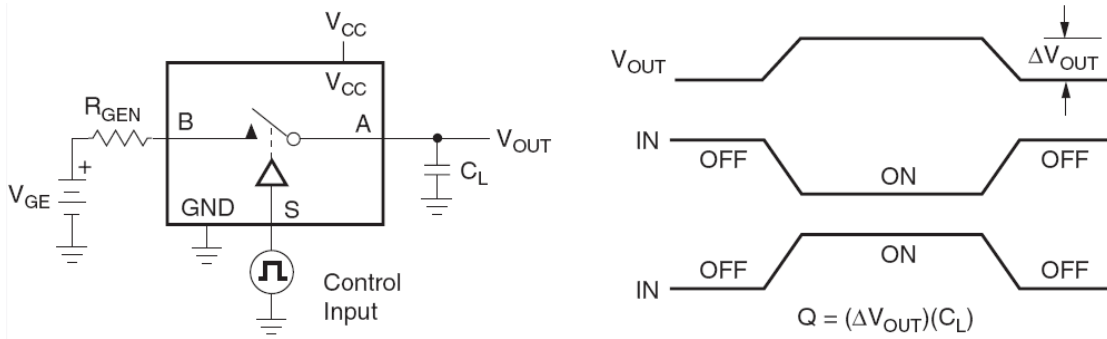

Figure 8. Charge Injection

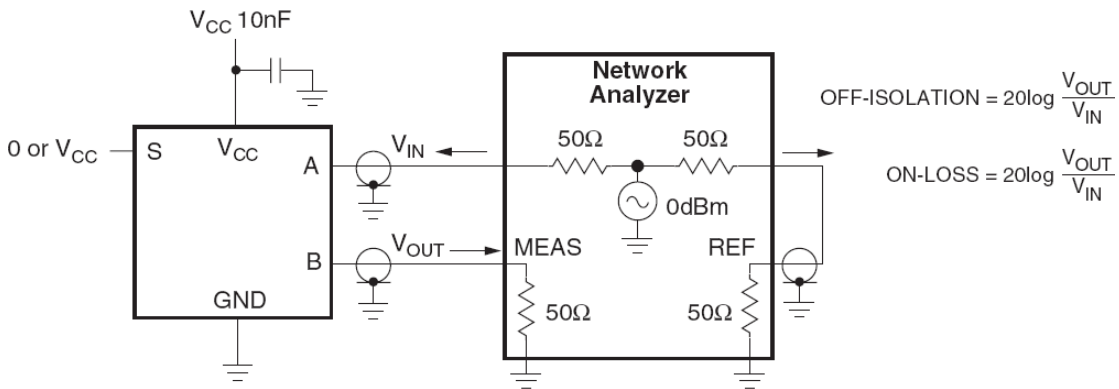

Figure 9. Off Isolation

FSA1156, FSA1157

AC LOADINGS AND WAVEFORMS (Continued)

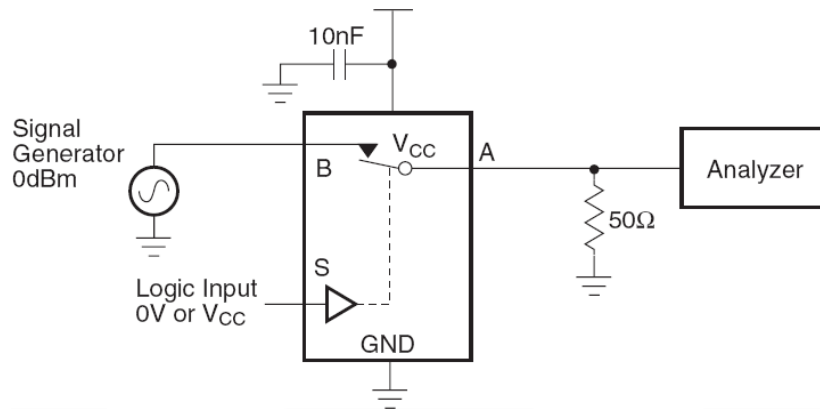

Figure 10. Bandwidth

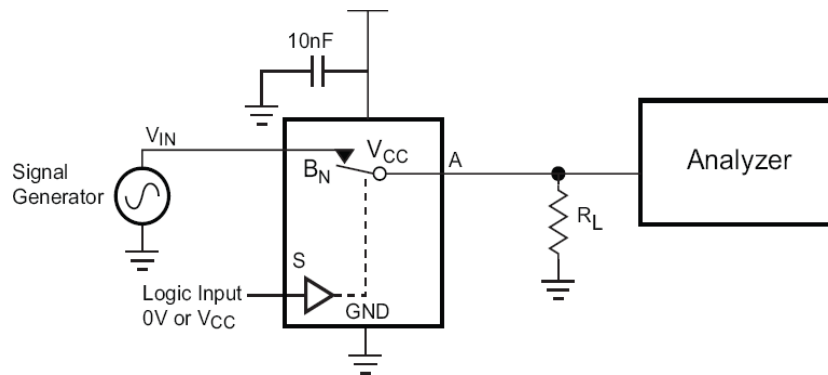

Figure 11. Harmonic Distortion

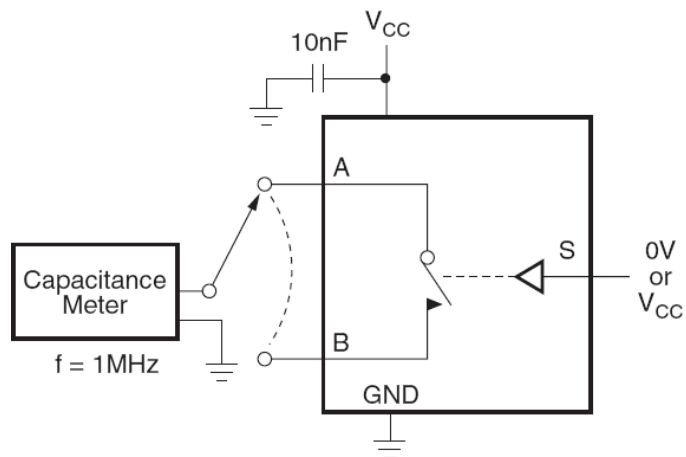

Figure 12. On / Off Capacitance

MicroPak is a trademark of Semiconductor Components Industries, LLC dba "onsemi" or its affiliates and/or subsidiaries in the United States and/or other countries.



SIP6 1.45X1.0
CASE 127EB
ISSUE O

DATE 31 AUG 2016

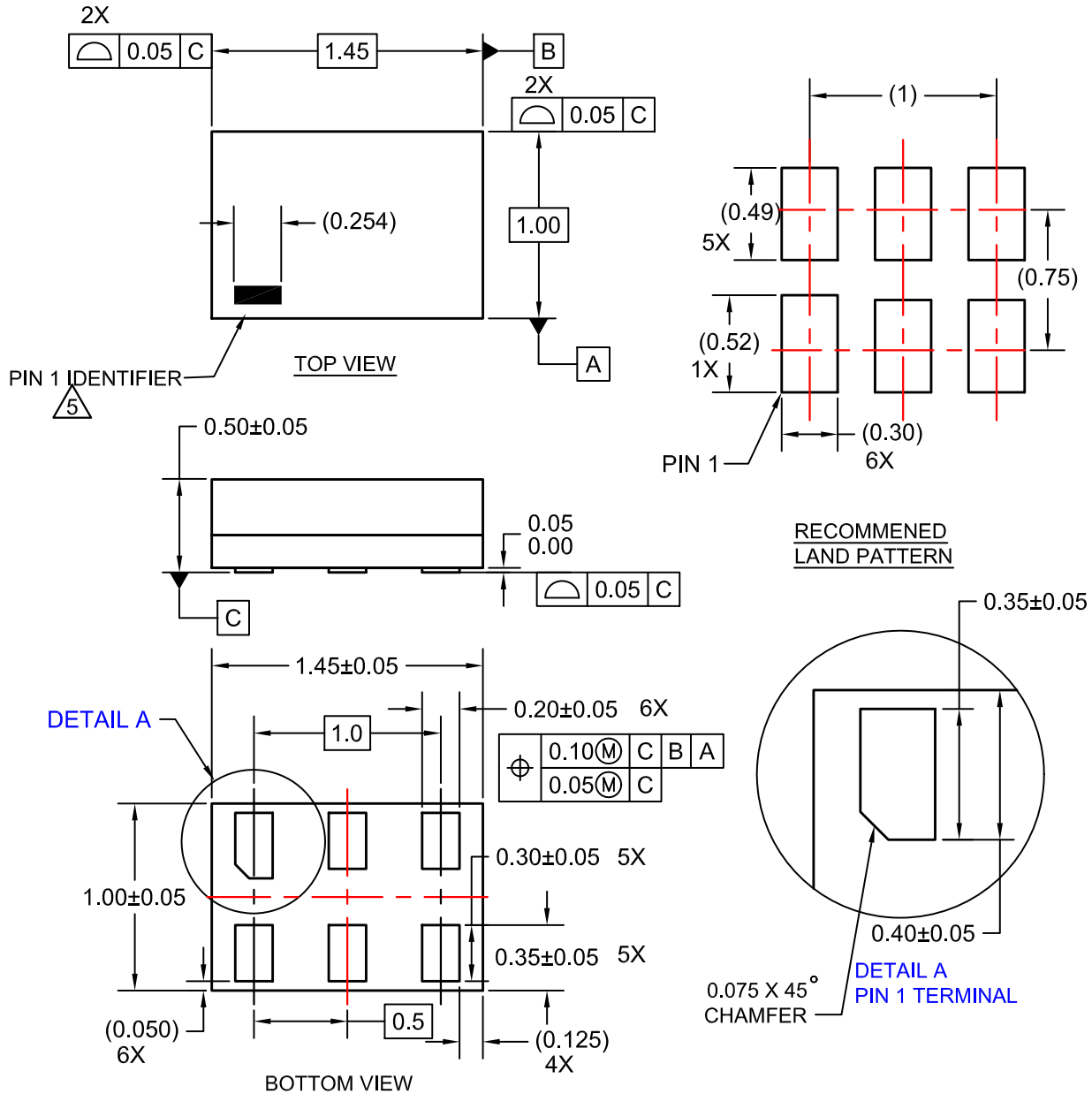

NOTES:

1. CONFORMS TO JEDEC STANDARD MO-252 VARIATION UAAD
2. DIMENSIONS ARE IN MILLIMETERS
3. DRAWING CONFORMS TO ASME Y14.5M-2009
4. PIN ONE IDENTIFIER IS 2X LENGTH OF ANY OTHER LINE IN THE MARK CODE LAYOUT.

DOCUMENT NUMBER:	98AON13590G	Electronic versions are uncontrolled except when accessed directly from the Document Repository. Printed versions are uncontrolled except when stamped "CONTROLLED COPY" in red.
DESCRIPTION:	SIP6 1.45X1.0	PAGE 1 OF 1

ON Semiconductor and are trademarks of Semiconductor Components Industries, LLC dba ON Semiconductor or its subsidiaries in the United States and/or other countries. ON Semiconductor reserves the right to make changes without further notice to any products herein. ON Semiconductor makes no warranty, representation or guarantee regarding the suitability of its products for any particular purpose, nor does ON Semiconductor assume any liability arising out of the application or use of any product or circuit, and specifically disclaims any and all liability, including without limitation special, consequential or incidental damages. ON Semiconductor does not convey any license under its patent rights nor the rights of others.

MECHANICAL CASE OUTLINE

PACKAGE DIMENSIONS

ON Semiconductor®



SC-88 (SC-70 6 Lead), 1.25x2
CASE 419AD-01
ISSUE A

DATE 07 JUL 2010

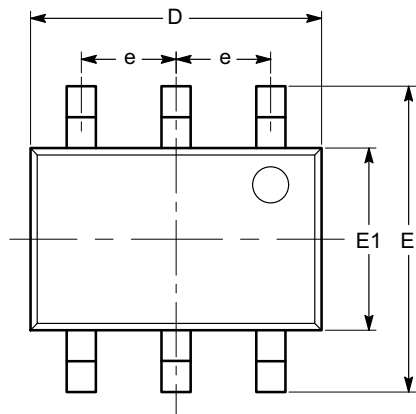

TOP VIEW

SYMBOL	MIN	NOM	MAX
A	0.80		1.10
A1	0.00		0.10
A2	0.80		1.00
b	0.15		0.30
c	0.10		0.18
D	1.80	2.00	2.20
E	1.80	2.10	2.40
E1	1.15	1.25	1.35
e	0.65 BSC		
L	0.26	0.36	0.46
L1	0.42 REF		
L2	0.15 BSC		
θ	0°		8°
θ_1	4°		10°

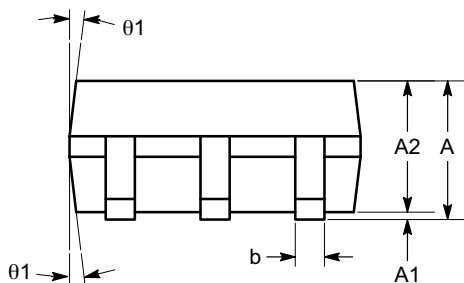

SIDE VIEW

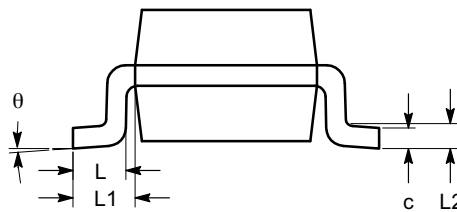

END VIEW

Notes:

- (1) All dimensions are in millimeters. Angles in degrees.
- (2) Complies with JEDEC MO-203.

DOCUMENT NUMBER:	98AON34266E	Electronic versions are uncontrolled except when accessed directly from the Document Repository. Printed versions are uncontrolled except when stamped "CONTROLLED COPY" in red.
DESCRIPTION:	SC-88 (SC-70 6 LEAD), 1.25X2	PAGE 1 OF 1

ON Semiconductor and are trademarks of Semiconductor Components Industries, LLC dba ON Semiconductor or its subsidiaries in the United States and/or other countries. ON Semiconductor reserves the right to make changes without further notice to any products herein. ON Semiconductor makes no warranty, representation or guarantee regarding the suitability of its products for any particular purpose, nor does ON Semiconductor assume any liability arising out of the application or use of any product or circuit, and specifically disclaims any and all liability, including without limitation special, consequential or incidental damages. ON Semiconductor does not convey any license under its patent rights nor the rights of others.

onsemi, **Onsemi**, and other names, marks, and brands are registered and/or common law trademarks of Semiconductor Components Industries, LLC dba "**onsemi**" or its affiliates and/or subsidiaries in the United States and/or other countries. **onsemi** owns the rights to a number of patents, trademarks, copyrights, trade secrets, and other intellectual property. A listing of **onsemi**'s product/patent coverage may be accessed at www.onsemi.com/site/pdf/Patent-Marking.pdf. **onsemi** reserves the right to make changes at any time to any products or information herein, without notice. The information herein is provided "as-is" and **onsemi** makes no warranty, representation or guarantee regarding the accuracy of the information, product features, availability, functionality, or suitability of its products for any particular purpose, nor does **onsemi** assume any liability arising out of the application or use of any product or circuit, and specifically disclaims any and all liability, including without limitation special, consequential or incidental damages. Buyer is responsible for its products and applications using **onsemi** products, including compliance with all laws, regulations and safety requirements or standards, regardless of any support or applications information provided by **onsemi**. "Typical" parameters which may be provided in **onsemi** data sheets and/or specifications can and do vary in different applications and actual performance may vary over time. All operating parameters, including "Typicals" must be validated for each customer application by customer's technical experts. **onsemi** does not convey any license under any of its intellectual property rights nor the rights of others. **onsemi** products are not designed, intended, or authorized for use as a critical component in life support systems or any FDA Class 3 medical devices or medical devices with a same or similar classification in a foreign jurisdiction or any devices intended for implantation in the human body. Should Buyer purchase or use **onsemi** products for any such unintended or unauthorized application, Buyer shall indemnify and hold **onsemi** and its officers, employees, subsidiaries, affiliates, and distributors harmless against all claims, costs, damages, and expenses, and reasonable attorney fees arising out of, directly or indirectly, any claim of personal injury or death associated with such unintended or unauthorized use, even if such claim alleges that **onsemi** was negligent regarding the design or manufacture of the part. **onsemi** is an Equal Opportunity/Affirmative Action Employer. This literature is subject to all applicable copyright laws and is not for resale in any manner.

PUBLICATION ORDERING INFORMATION

LITERATURE FULFILLMENT:

Email Requests to: orderlit@onsemi.com

onsemi Website: www.onsemi.com

TECHNICAL SUPPORT

North American Technical Support:

Voice Mail: 1 800-282-9855 Toll Free USA/Canada

Phone: 011 421 33 790 2910

Europe, Middle East and Africa Technical Support:

Phone: 00421 33 790 2910

For additional information, please contact your local Sales Representative