

FOSC 450

Gel-Sealed Fiber Optic Splice Closure

2nd Edition

Contents

Welcome to the FOSC 450 Fiber Optic Splice Closure Ordering Guide. This Guide is designed to provide you with the information you need to specify and purchase FOSC 450 splice closures and accessories you need for your fiber network.

FOSC 450 fiber optic splice closures are used worldwide!

Please note that this ordering guide is designed for FOSC 450 closures as they are configured for North America, Mexico, the Caribbean, and Central America. For information regarding FOSC 450 closures for other areas of the world, please refer to www.te.com/FOSC450 or contact your local sales or customer service representative.

Product Introduction

Closure Overview	5
FOSC 450 Closure Family	5
Splice Capacities and Characteristics Chart.....	6
Typical Closure Kit Contents	7

Ordering Information

Ordering Introduction	8
Description and Ordering Key	8
Commonly Requested Kit Configurations.....	9
Commonly Requested Accessory Kits	10

FOSC 450 Closure Accessories

General Information	11
Cable Termination Accessories.....	11
Cable Sealing Accessories.....	12
Splice Tray Accessories.....	13
Fiber Management and Routing Accessories	15
Slack Storage Basket Accessories.....	15
Grounding Accessories	15
Closure Mounting Hardware Accessories	16
Splitters Description Key and Product List.....	17
CWDM's Description Key and Product List	20
Passives: CWDM Kits	23
Passives: DWDM Kits	26
DWDM's Description Key	30
Miscellaneous Accessories	32

Additional FOSC Closure Products

Introduction to Additional FOSC Closure Products	23
FOSC Closure Family.....	23

Engineering Information

Engineering Information	34
Closure Information.....	34
FOSC 450 Closure Family Drawings	34
Splice Tray Dimension	35
FOSC Fiber Optic Splice Closures.....	36
Quick Reference Guide	36
Index	37

Information subject to change. For the latest information, see the FOSC 450 Closure Ordering Guide at:
<http://www.te.com/FOSC450>

FOSC 450

Gel-Sealed Fiber Optic Splice Closure

FOSC 450

Fiber Optic Splice Closure Family

A FAMILY OF CLOSURES DESIGNED FOR YOUR FIBER NETWORK NEEDS!

FOSC 450 fiber optic splice closures are a family of single-ended closures designed for use most anywhere there are fiber splicing and storage needs.

THESE CLOSURES ARE AVAILABLE IN FIVE SIZES, EACH FEATURING:

- Re-usable compressed gel cable sealing components that accommodate a wide range of cable sizes
- Capability to accommodate a variety of cable styles including loose tube or central core tube cables with single or ribbon fibers
- Hinging splicing trays that provide controlled access to splices and slack storage
- Splice and storage compartments accessible via a removable dome-clamp system
- Thermoplastic outer materials that withstand temperature and contaminate extremes
- Slack storage baskets of various sizes that provide different slack storage scenarios
- Many shared components between closure sizes
- A range of accessories for a variety of outside plant needs



450 A

SMALLEST OF THE FOSC 450 CLOSURE FAMILY

- 4 cable entry ports, each with multi-cable capability
- 96 single fiber/144 mass splice capacity
- 19" long by 8" diameter*
- Capacity of up to 8 drop cables in addition to a feed-through cable
- Compact size for FTTH applications
- Accessories available for a wide variety of applications



450 B Short

ONE OF THE SMALLER 450 CLOSURES

- 6 cable entry ports, each with multi-cable capability
- 144 single fiber/288 mass splice capacity
- 19" long by 9.2" diameter*
- Uses A size splice trays
- Capacity of up to 16 drop cables in addition to a feed-through cable
- Fits applications requiring large splice capacity in a small size
- Accessories available for a wide variety of applications



450 B

THE MID-SIZE FOSC 450 CLOSURE

- 6 cable entry ports, each with multi-cable capability
- 144 single fiber/288 mass splice capacity
- Increased slack storage capacity over the B Short closure
- 24" long by 9.8" diameter*
- Capacity of up to 16 drop cables in addition to a feed-through cable
- Accessories available for a wide variety of applications



450 C

COMBINING THE WELL ACCEPTED FOSC 450 D CLOSURE WITH A SHORT OVERALL LENGTH (23"), THE 450 C FITS APPLICATIONS WHERE INCREASED SPLICE CAPACITY AND SMALL SIZE ARE A MUST

- 6 cable entry ports, each with multi-cable capability
- 192 single fiber/864 mass splice capacity
- 23" long by 11.5" diameter*
- Capacity of up to 16 drop cables in addition to a feed-through cable
- Wide-style splice tray
- Accessories available for a wide variety of applications
- Field upgradeable to the 450D size



450 D

THE LARGEST OF THE FOSC 450 CLOSURE LINE, THE 450 D IS CAPABLE OF HANDLING A WIDE RANGE OF FIBER CLOSURE NEEDS

- 6 cable entry ports, each with multi-cable capability
- 576 single fiber/1152 mass splice capacity
- 30" long by 11.5" diameter*
- Wide-splice tray
- Accessories available for patching, rehabilitation and a wide variety of applications
- Capacity of up to 16 drop cables in addition to a feed-through cable

*Diameter measurements are based on the widest diameter points and include the clamp hinge and latching mechanisms. Diameters of the clamps not including the hinge and latch are approximately 1 inch less.

FOSC 450

Closure Capacities and Characteristics

These charts represent the capacities of each of the FOSC 450 closure sizes. Capacities may vary due to application variables, such as the amount of slack storage required.

Single Fiber Application



Ribbon Application Using Ribbon Trays

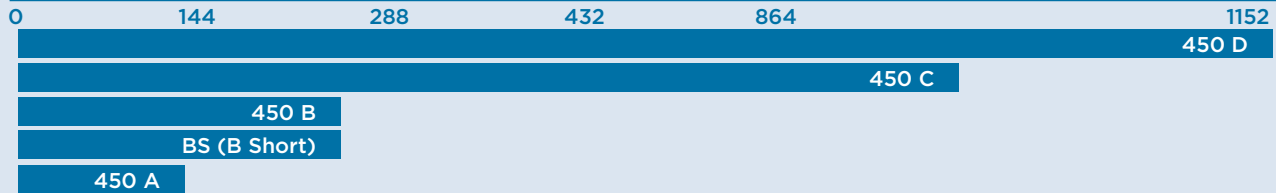

Characteristics Chart

Type/Size	D6	C6	B6	BS	A4
Closure Size ¹ (inches)	11.5 dia. 30 L	11.5 dia. 23 L	9.8 dia. 24 L	9.2 dia. 19 L	8 dia. 19 L
Approx. Closure Weights (lbs)	20	16	13	10	6
Closure Capacity					
End-to-End Splicing					
Single Splice (SM6 Modules)	288	96	72	72	48
Single Splice (SM12 Modules) ²	576	192	144	144	96
Mass Fusion Splice	1152	864	288	144	144
Mid-Sheath Splicing					
Single Splice	576	192	144	144	72
Mass Fusion Splice	864	432	288	288	216
Trays Per Closure					
Standard Trays	8 ⁵ / 6 ³ / 5 ⁴	8 ⁵ / 6 ³ / 5 ⁴	6 ⁵ / 6 ³ / 4 ⁴	6 ⁵ / 6 ³ / 2 ⁴	4 ⁵ / 3 ³ / 2 ⁴
Ribbon Trays	4 ⁵ / 3 ³ / 2 ⁴	4 ⁵ / 3 ³ / 2 ⁴	3 ⁵ / 3 ³ / 2 ⁴	3 ³	1 ³
Single Fiber Splice Capacity per Tray					
SM6 Modules	36	12	12	12	12
SM12 Modules ²	72	24	24	24	24
FIST Modules ²	96	n/a	n/a	n/a	n/a
Patching					
Tray (quantity/type)	Yes (12,16/sc)	No	Yes (12,16/sc)	No	No
Basket (quantity/type)	Yes (4/all, 8/sc)	No	Yes (4/all, 8/sc)	Yes (4/all, 8/sc)	Yes (4/all, 8/sc)
Sealing System					
Closure Dome-to-Base or Top-to-Bottom	"O" Ring/ Clamp	"O" Ring/ Clamp	"O" Ring/ Clamp	"O" Ring/ Clamp	"O" Ring/ Clamp
Cable Capacity					
Butt (std./max.)	6 / 16 ⁷ / 21 ⁸	6 / 16 ⁷ / 21 ⁸	6 / 16 ⁷ / 21 ⁸	6 / 16 ⁷ / 21 ⁸	4 / 10 ⁷ / 13 ⁸
Inline (std./max.)	n/a	n/a	n/a	n/a	n/a
Fire Retardant Closure Available	No ^{9,10}	No ⁹	No ^{9,10}	No ⁹	No ⁹
Tools Required	Can Wrench, Snips	Can Wrench, Snips	Can Wrench, Snips	Snips	Can Wrench Snips

¹Closure length ("L") plus 10X largest cable diameter installed equals the overall length required for handhole. Maximum dimensions includes clamp and cable sealing.

²SMOUV splice protection sleeves should be used.

³With standard basket.

⁴With tall basket.

⁵Flexible sock is used for LBT storage.

⁶The ribbon tray can also be configured with 12 SC adapters for patching and provide 12 single splice capacity.

⁷If using the 3-cable Multicable kit, 3 flat or 3 round cables per port if cable does not exceed <0.25" diameter.

⁸If using the 4-cable Multicable kits and combined cables do not exceed 1" diameter.

⁹Fire Retardant bag or blanket options.

¹⁰Fire Retardant closures available in FOSC 400 family.

FOSC 450

Typical Closure Kit Contents

Typical Closure Kit Contents include

- Dome
- Clamp
- O-ring
- Base
- Gel sealing block with compression trigger
- Plugs for unused cable ports
- Tray tower to hold hinging FOSC splice trays
- FOSC splice trays (quantity according to the ordering description)
- Cable retention hardware (quantity according to the ordering description)
- Miscellaneous hardware, including fiber routing (transportation) tubing, cable retention clamps, strength member retainers, etc.
- Installation Instructions



Dome - The dome is made from a polymer, with ribbing added for extra strength. Five different sizes are available (A, BS, B6, C6, D6), matching the five closure sizes in the family.



Base - The base houses the gel block cable sealing system and is the foundation for the tray tower and cable attachment/retention hardware.



Gel Block with Trigger - The gel block provides the sealing mechanism for cables entering the closure. Available with six cables entry ports (450 B, BS, C or D) or four (450 A size only). Not Sold Separately.



Dome to Base Seal - Domes are attached to the base by means of a clamp. Dome-to-base sealing is accomplished via a compressed O-ring.



Cable Retention Hardware - Cable strain relief and strength member termination hardware.

FOSC 450

Making the Information Work for You

FOSC 450 fiber optic splice closures can be ordered in a variety of configurations to maximize efficiency and minimize up front cost. The following pages provide closure choices and the steps to be followed when specifying FOSC 450 closure configurations. In addition, we have supplied a list of commonly requested closure configurations.

Follow the steps to choose the desired closure. Then simply match the step to the description key. See *Quick Reference Guide in the back of this catalog for additional details*



- 1** Closure Size: A4, BS (B Short), B6, C6, or D6
- 2** Termination Hardware Quantity for the Kit: 2, 4, or 6
- 3** Capacity and Type of Splice Tray
- 4** Quantity of Splice Trays Factory Installed (Choose either "0" trays (no trays installed) or "1" tray installed. Additional trays sold separately.)
- 5** Slack Basket Type
- 6** Feed-through Ground Quantity
- 7** Whether Flash Test Valve is Desired (Valved version is standard)



1 Closure Size (inches)

A4	4 cable entry ports; 8 dia. x 19 long
BS	6 cable entry ports; 9 dia. x 19.5 long
B6	6 cable entry ports; 10 dia. x 24 long
C6	6 cable entry ports; 11.5 dia. x 23 long
D6	6 cable entry ports; 11.5 dia. x 30 long

2 Termination Hardware Quantity for the Kit

2	2 cable attachments included
4	4 cable attachments included
6	6 cable attachments included (N/A for A size)

3 Capacity and Type of Splice Tray

NT	No tray installed in factory
12	A, B, or C tray with two SM6 splice modules
24*	A, B, or C tray with two SM12 splice modules
36	D tray with six SM6 splice modules
72*	D tray with six SM12 splice modules
R1	A, B size ribbon tray (accommodates 12 ribbons/144 fibers)
R2	D size ribbon tray (24 ribbons/288 fibers)
R3	C size ribbon tray (18 ribbons/216 fibers)
SF	Stackable single fusion trays (12 splices)

4 Quantity of Splice Trays Factory Installed

0 or 1 is standard	Choose either "0" trays (no trays installed) or "1" tray installed. Additional trays sold separately.
---------------------------	---

7 Valve for Flash Testing

V	Valve (standard)
N	No Valve

Note: We recommend flash test valves for FOSC closures. However, non-valved closures are available upon request.

6 Number of Ground Feed-through Lugs

0	No grounding
1	1 ground feed-through lug (A4 only, N/A for BS)
3	3 ground feed-through lugs (B6, C6, and D6 closures only, N/A for BS)
6	6 ground feed-through lugs (C6 and D6 closure only, N/A for BS)

Note: FEG and MEG kits provide optional ground isolation for FOSC 450 closures.

5 Slack Basket Type

N	No Basket
A	A4 Standard Size
B	B6, BS Standard Size
C	C6 Standard Size
D	D6 Standard Size
E	Special Bulkhead Basket arrangement for B, BS closures only
T	Tall Size
S	Stackable Trays in D Closure

Note: D-size closures with "N" option include backbone used to route ribbons to ribbon trays. A and B-size closures include storage "socks".

*Note: SMOUV (1120-01) splice protection sleeves are highly recommended for use with SM12 splice modules.

FOSC 450

Commonly Requested Closure Kits

In order to provide customers with cost and inventory efficient options, FOSC 450 fiber optic splice closures are classified in three categories as shown below.

CLASS A LIST: Basic kits. Lower comparable cost. Lowest targeted lead time.

FOSC 450A	FOSC 450B Short	FOSC 450B	FOSC 450C	FOSC 450D
FOSC450-A4-4-NT-0-A1V	FOSC450-BS-6-NT-0-B0V	FOSC450-B6-6-NT-0-B3V	FOSC450-C6-6-NT-0-C6V	FOSC450-D6-6-NT-0-D6V
FOSC450-A4-4-NT-0-N0V	FOSC450-BS-4-NT-0-N0V	FOSC450-B6-4-NT-0-N0V	FOSC450-C6-4-NT-0-N0V	FOSC450-D6-4-NT-0-N0V
FOSC450-A4-4-NT-0-N1V		FOSC450-B6-4-NT-0-N3V	FOSC450-C6-4-NT-0-N3V	FOSC450-D6-4-NT-0-N3V

CLASS B LIST: Standard kits. Includes splice tray, basket, and grounding options.

FOSC 450A	FOSC 450BS	FOSC 450B	FOSC 450C	FOSC 450D
FOSC450-A4-4-12-1-A0V	FOSC450-BS-6-12-1-B0V	FOSC450-B6-6-12-1-B0V	FOSC450-C6-6-12-1-C0V	FOSC450-D6-6-36-1-D0V
FOSC450-A4-4-12-1-A1V	FOSC450-BS-6-12-1-T0V	FOSC450-B6-6-12-1-B3V	FOSC450-C6-6-12-1-C3V	FOSC450-D6-6-36-1-D3V
FOSC450-A4-4-24-1-A0V	FOSC450-BS-6-24-1-B0V	FOSC450-B6-6-24-1-B0V	FOSC450-C6-6-12-1-C6V	FOSC450-D6-6-36-1-D6V
FOSC450-A4-4-24-1-A1V	FOSC450-BS-6-24-1-T0V	FOSC450-B6-6-24-1-B3V	FOSC450-C6-6-24-1-C0V	FOSC450-D6-6-72-1-D0V
FOSC450-A4-4-NT-0-A0V		FOSC450-B6-6-NT-0-B0V	FOSC450-C6-6-24-1-C3V	FOSC450-D6-6-72-1-D3V
FOSC450-A4-4-R1-1-A0V		FOSC450-B6-6-R1-1-B0V	FOSC450-C6-6-24-1-C6V	FOSC450-D6-6-72-1-D6V
FOSC450-A4-4-R1-1-A1V		FOSC450-B6-6-R1-1-B3V	FOSC450-C6-6-NT-0-C0V	FOSC450-D6-6-NT-0-D0V
FOSC450-A4-4-NT-0-T0V		FOSC450-B6-6-NT-0-T0V	FOSC450-C6-6-R3-1-C0V	FOSC450-D6-6-R2-1-D0V
FOSC450-A4-4-NT-0-T1V		FOSC450-B6-6-NT-0-T3V	FOSC450-C6-6-R3-1-C3V	FOSC450-D6-6-R2-1-D3V
			FOSC450-C6-6-R3-1-C6V	FOSC450-D6-6-R2-1-D6V
			FOSC450-C6-6-NT-0-T0V	FOSC450-D6-6-NT-0-T0V
			FOSC450-C6-6-NT-0-T6V	FOSC450-D6-6-NT-0-T6V

CLASS C LIST: Non-standard kits. Contact your local salesperson for further information.

All other closure configurations are available as Class C products. Contact your salesperson for further information.

Information subject to change. For the latest information, see the FOSC 450 Closure Ordering Guide at:
<http://www.te.com/FOSC450>

COMMONLY REQUESTED ACCESSORY KITS

Splice Trays - FOSC 450 fiber optic splice closures are accompanied by a wide variety of splice trays and tray accessories including those for storing single and/or ribbon (mass) fusion splices, ribbon splices with ribbon slack on the same tray, and patching trays.

Multi-Cable Sealing Accessories - FOSC 450 closures can accommodate multiple cables entering a cable entry port by utilizing multi-cable sealing kits. Several styles of multi-cable kits are available.

Mounting Hardware - Many mounting hardware options are available for mounting closures in the various outside plant environments.

Slack Storage Baskets - Closures are typically supplied with standard size slack storage baskets. Tall version baskets (for storing additional slack) are also available.

Splitters and WDM's - A wide range of splitters and CWDM's are available, whether on FOSC trays or field installable.

See the Accessories section, pages 11-18, for additional details.

EXTRAS THAT MAKE YOUR JOB EASIER

While each FOSC 450 closure kit comes outfitted with components needed for installation, a full line of accessories is also available—from splice trays, to multi-cable-per-port sealing kits, to a range of mounting hardware options—to meet your splice closure needs.

The following is a listing of the most commonly requested accessories, categorized for your convenience. Additional accessories are also available.

For more information, check our website: www.te.com/TelecomNetworks or contact your local salesperson or our Customer Service team for additional information.



450 A Cable Retention Plate



450 BS, B, C, D Cable Retention Plate B version shown

CABLE TERMINATION ACCESSORIES

Closure Size	Kit Contents	Cables	Grounding Hardware	Kits/ Pkg.	Part Number	Description
A Only	Cable retention hardware, strength member retention hardware	1 Port	No	5	D20592-000	FOSC-ACC-450-A-CBLTERM
A Only	Cable retention hardware; strength member retention hardware	1 Port	Yes	5	C67369-000	FOSC-ACC-450-A-CBLTERM-G
BS Only	4 sets each: cable retention hardware (with hose clamps), strength member retention hardware	4 Ports	No	1	D25359-000	FOSC450-CABLE-TERM-4-BS
B, C, D	2 sets each: cable retention hardware (with hose clamps), strength member retention hardware	2 Ports	No	1	F67166-000	FOSC450-CABLE-TERM-2-N
B, C, D	2 sets each: cable retention hardware (with hose clamps), strength member retention hardware; ground wires	2 Ports	Yes	1	C61629-000	FOSC450-CABLE-TERM-2-G
B, C, D	4 sets each: cable retention hardware (with hose clamps), strength member retention hardware	4 Ports	No	1	558850-000	FOSC450-CABLE-TERM-4-N
B, C, D	4 sets each: cable retention hardware (with hose clamps), strength member retention hardware, ground wires	4 Ports	Yes	1	659136-000	FOSC450-CABLE-TERM-4-G

Closure Sealing Accessories

Closure Size	Cables Sealed ¹	Key Sealing Components	Kits/Pkg.	Part Number	Description
Multiple Cables/Drop Cables per Port Seals					
All	3	Quick Install Gel Plug	10	A38215-000	FAK-MULDRP-45-3-DRP
				40606V-000	FAK-MULDRP-45-3/CBL-ATT*
	4	Gel Tape Wrap		41606V-000	FAK-MULDRP-45-4-DRP
				E21473-000	FAK-MULDRP-45-4/CBL-ATT*
		Quick Install Gel Plug		XJ261N-000	FAK-MULDRP-45-4P-DRP
				1F6818-000	FAK-MULDRP-45-4P/CBL-ATT*
Closure Size: 450 B, BS, C, D	4	Mini Gel Sealing Block		CZ3388-000	FAK-MULDRP-45-SEAL-FLAT4



3-Cable Seal with Cable Attachment Kit (assembled)

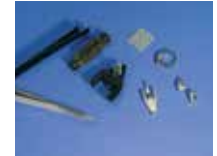

4-Cable Seal with Cable Attachment Kit

Closure Size	Cables Sealed ¹	Key Sealing Components	Kits/Pkg.	Part Number	Description
Port Plugs (used to plug empty cable ports)					
All	N/A	Port Plug	50	A05721-000	FOSC-ACC-450-PORT-PLUGS
Replacement O-Rings (fits between dome and base)					
450A	N/A	O-Ring	5	381107-000	FOSC-ACC-400AB-450A-ORIN
450BS	N/A	O-Ring	5	HG302N-000	FOSC-ACC-450-BS-ORING
450B	N/A	O-Ring	5	A51343-000	FOSC-ACC-450-B-ORING
450C	N/A	O-Ring	5	429631-000	FOSC-ACC-D-O-RING-SEAL
450D	N/A	O-Ring	5	429631-000	FOSC-ACC-D-O-RING-SEAL

¹ Combined cable diameters must be within cable port size requirements.

*Cable attachments included

Splice Tray Accessories

FEATURES

Variety of splice trays, capacities, options
Single and ribbon fiber styles



ORDERING INFORMATION

Closure Size	Tray Capacity	Includes Protection Sleeve?	Kits include instructions, tie-wraps, tray and clear cover with:	Kits/Pkg.	Part Number	Description
A	12	No	2 SM-6 splice modules	2	497817-000	FOSC-ACC-A-TRAY-12
A	12	Yes	2 SM-6 splice modules, 12 60MM SMOUV splice protection sleeves	2	HL0017-000	FOSC-ACC-A-TRAY-12-SMV60
A	24*	No	2 SM-12 splice modules	2	429567-000	FOSC-ACC-A-TRAY-24
A	24	Yes	2 SM-12 splice modules, 25 60MM SMOUV splice protection sleeves	2	EB063E-000	FOSC-ACC-A-TRAY-24-SMV60
BS	12	No	2 SM-6 splice modules	2	497817-000	FOSC-ACC-A-TRAY-12
BS	12	Yes	2 SM-6 splice modules, 12 60MM SMOUV splice protection sleeves	2	HL0017-000	FOSC-ACC-A-TRAY-12-SMV60
BS	24*	No	2 SM-12 splice modules	2	429567-000	FOSC-ACC-A-TRAY-24
BS	24	Yes	2 SM-12 splice modules, 25 60MM SMOUV splice protection sleeves	2	EB063E-000	FOSC-ACC-A-TRAY-24-SMV60
B	12	No	2 SM-6 splice modules	2	898849-000	FOSC-ACC-B-TRAY-12
B	12	Yes	2 SM-6 splice modules, 12 60MM SMOUV		G68315-000	FOSC-ACC-B-TRAY-12-SMV60
B	24*	No	2 SM-12 splice modules	2	863927-000	FOSC-ACC-B-TRAY-24
B	24	Yes	2 SM-12 splice modules, 25 60MM SMOUV splice protection sleeves	2	Z75279-000	FOSC-ACC-B-TRAY-24-SMV60
C	12	No	2 SM-6 splice modules	2	RH0198-000	FOSC-ACC-C-TRAY-12
C	12	Yes	2 SM-6 splice modules, 12 60MM SMOUV splice protection sleeves	2	X35373-000	FOSC-ACC-C-TRAY-12-SMV60
C	24*	No	2 SM-12 splice modules	2	RH0202-000	FOSC-ACC-C-TRAY-24
C	24	Yes	2 SM-12 splice modules, 25 60MM SMOUV splice protection sleeves	2	C4388W-000	FOSC-ACC-C-TRAY-24-SMV60
C	36	Yes	3 FIST style modules, 36 60MM SMOUV splice protection sleeves	2	EM5842-000	FOSC-ACC-C-TRAY-36-S60
D	00	No	Tray and clear cover, no splice modules. Includes tie-wraps, instructions.	2	122131-000	FOSC-ACC-D-TRAY-00
D	36	No	6 SM-6 splice modules	2	426579-000	FOSC-ACC-D-TRAY-36
D	36	Yes	6 SM-6 splice modules, 40 60MM SMOUV splice protection sleeves	2	DK696L-000	FOSC-ACC-D-TRAY-36-SMV60
D	48	No	6 SM-8 splice modules	2	579575-000	FOSC-ACC-D-TRAY-48
D	72*	No	6 SM-12 splice modules	2	915167-000	FOSC-ACC-D-TRAY-72
D	72	Yes	6 SM-12 splice modules, 75 60MM SMOUV splice protection sleeves	2	JL0937-000	FOSC-ACC-D-TRAY-72-SMV60
D	96	Yes	8 FIST style splice modules, 100 60MM SMOUV splice protection sleeves	2	F10669-000	FOSC-ACC-D-TRAY-96-S60

* TE's SMOUV splice sleeves highly recommended for use with these trays.

FOSC 450

Accessories



A/B Ribbon Tray Kit

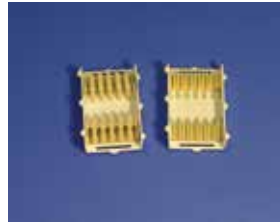

Individual Splice Modules



D-12 Patch Tray



D-16 Patch Tray

ORDERING INFORMATION

	Tray Capacity	Kit Includes	Kits/ Pkg.	Part Number	Description
Ribbon Fiber Trays					
A or B	144 Mass Fusion (12 fiber ribbon x 12 splices)	A/B Size Ribbon Tray with clear cover, 2 SM-6 splice modules, tie-wraps, instructions	1	709972-000	FOSC-ACC-A/B-TRAY-12-RBN
C	216 Mass Fusion (12 fiber ribbon x 18 splices)	C Size Ribbon Tray with clear cover, 3 SM-6 splice modules, tie-wraps, instructions	1	398955-000	FOSC-ACC-C-TRAY-RIBN-18
D	288 Mass Fusion (12 fiber ribbon x 24 splices)	D Size Ribbon Tray with clear cover, 4 SM-6 splice modules, tie-wraps, instructions	1	061064-000	FOSC-ACC-D-TRAY-RIBN-24
Patch Trays					
B	16 fiber patch tray	B-size Patch Tray with adapter retainer. Holds up to 16 SC style adapters.	1	A38455-000	FOSC-ACC-B-TRAY-P-16-0
D	16 fiber patch tray	D-size Patch Tray with adapter retainer. Holds up to 16 SC style adapters.	1	C03247-000	FOSC-ACC-D-TRAY-P-16-0
D	12 fiber patch tray	D-size Patch Tray, adapter retainer, no adapters installed	1	P5387P-000	FOSC-ACC-D-TRAY-P-12-0
D	12 fiber patch tray	D-size Patch Tray, adapter retainer, and 12 SC/APC style adapters	2	C91240-000	FOSC-ACC-D-TRAY-P-SC/APC
D	12 fiber patch tray	D-size Patch Tray, adapter retainer, and 12 SC/UPC style adapters.	2	E90832-000	FOSC-ACC-D-TRAY-P-SC/UPC
Splice Tray Covers					
A or BS		1 clear A-size tray cover	25	90887R-000	FOSC-ACC-A-TRAY-COVER
B		1 clear B-size tray cover	25	Y66598-000	FOSC-ACC-B-TRAY-COVER
C		1 clear C-size tray cover	25	YD926E-000	FOSC-ACC-C-TRAY-COVER
D		1 clear D-size tray cover	25	ZP0533-000	FOSC-ACC-D-TRAY-COVER
Splice Modules (for replacing or adding modules to trays)					
All		6-splice capacity snap-in module	48	581981-000	FOSC-ACC-SM6-MODULES
All		8-splice capacity snap-in module	48	332341-000	FOSC-ACC-SM8-MODULES
All		12-splice capacity snap-in module	48	275897-000	FOSC-ACC-SM12-MODULES**
All		12-splice capacity (high density) snap-in module	100	B86578-000	FOSC-ACC-SPLCEHLDR12-SMV

*Splice tray dimensional information can be found in the Engineering Section.

**TE's SMOUV splice sleeves are highly recommended for use with these trays/modules.

FOSC 450

Accessories

SMOUV Splice Protection Sleeves

Fiber Type	Sleeve Information	Kits/ Pkg.	Part Number	Description
SMOUV Fusion Splice Protection Sleeves				
Single Fiber	Heat-shrinkable, 61 mm, single fiber splice protection sleeve	1000	369305-000	SMOUV-1120-01
Single Fiber	Heat-shrinkable, 45 mm, single fiber splice protection sleeve	1000	103897-000	SMOUV-1120-02
Ribbon Fiber	Heat-shrinkable, 42 mm, 12 fiber ribbon splice protection sleeve	1000	757849-000	SMOUV-1120-R2/12

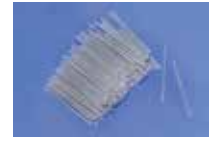

Fiber Management and Routing Accessories

SINGLE AND RIBBON FIBER

Closure Sizes	Tubing Style	Kit Includes	Std. Pack	Part Number	Description
All	Transportation	Six 16 inch pieces	240	526767-000	FOSC-ACC-TTUBE-SMLL-16IN
		One 50 foot section	10	829333-000	FOSC-ACC-TTUBE-SMLL-50FT
		Six 16 inch pieces	240	118317-000	FOSC-ACC-TTUBE-LRGE-16IN
		One 50 foot section	10	646311-000	FOSC-ACC-TTUBE-LRGE-50FT
		Six 16 inch pieces	240	577809-000	FOSC-ACC-TTUBE-RBN12-16I
		One 50 foot section	10	226809-000	FOSC-ACC-TTUBE-RBN12-50
		Six 16 inch pieces	240	F2103R-000	FOSC-ACC-TTUBE-RBN16I
		One 50 foot section	10	57581K-000	FOSC-ACC-TTUBE-RIBN24-50
	Buffer Tube Wrap	One wrap	100	RH0073-000	FOSC-ACC-LBTWRAP-100
	Spiral	One 500 foot roll	1	234855-000	FOSC-ACC-SPRLTUBE-1/8
		Two 100 foot rolls	1	469031-000	FOSC-ACC-SPRLTUBE-3/16
		One 25 foot section	1	RH0090-000	FOSC-ACC-SPRLTBE-3/16-25
One 50 foot section		1	460490-000	FOSC-ACC-SPRLTBE-3/8-50	



118317-000



829333-000

Slack Basket Accessories

Various styles are available for regular or increased slack storage, including adding baskets to existing closure kits that are without baskets.

Basket Style	Closure Sizes	Kits per Pkg.	Part Number	Description
Standard	A	1	E14672-000	FOSC-ACC-A8/450A-BASKET
	BS	1	457507-000	FOSC-ACC-B-BASKET
	B	1	457507-000	FOSC-ACC-B-BASKET
	C	1	RH0199-000	FOSC-ACC-C-BASKET
	D	1	089279-000	FOSC-ACC-D-BASKET
Tall	A	1	A91433-000	FOSC-ACC-450A4-BASKET-T
	BS	1	F53958-000	FOSC-ACC-B-BASKET-TALL
	B	1	F53958-000	FOSC-ACC-B-BASKET-TALL
	C	1	RH0200-000	FOSC-ACC-C-BASKET-TALL
	D	1	056395-000	FOSC-ACC-D-BASKET-TALL



089279-000

Note: Tall style slack storage baskets provide increased slack storage over standard baskets, but may reduce the closure's splice tray capacity.

Grounding Accessories

	Kit Includes	Kits per Pkg.	Part Number	Description
Grounding accessory kits include	Groundwire and associated hardware to add 1 ground to any FOSC 450 closure	5	A33560-000	FOSC-ACC-450-FIBRGRD-KIT
	Groundwire and associated hardware to add up to 3 grounds to any FOSC 450 closure*	5	449105-000	FOSC-ACC-MULT-EXT-GRND-3
	Groundwire and associated hardware to add 6 grounds to any FOSC 450 closure*	5	671575-000	FOSC-ACC-MULT-EXT-GRND-6
	Groundwires (alligator clip one end, eyelet on other) and bonding braid to bond up to 6 cables together	5	A11796-000	FOSC-ACC-450-COM-GRD-A
	Groundwires (eyelets on each end for use with B-Bonds) and bonding braid to bond up to 6 cables together	5	D46439-000	FOSC-ACC-450-COM-GRD-B
	RUS Style B Bonds	100	92733M-000	FOSC-ACC-RUS-B-BONDS

* Grounds are placed through one of the cable ports.

Closure Mounting Hardware Accessories

Below are a variety of mounting hardware options for 450 closures.

A	BS	B	C	D	Std. Pack	Kit Includes	Part Number	Description
AERIAL								
•	•	•	•	•	10	2 hanger brackets and clamps, 2 Snaplock* clamps, 2 lashing straps	663259-000**	FOSC-ACC-AERIAL-CLAMPS
•	•	•	•	•	10	1 dome mounting bracket, 1 base mounting bracket, 2 Snaplock* clamps, associated hardware	A13909-000**	FOSC-ACC-450-AERIAL-CLMP
•	•	•	•	•	10	2 metallic lashing straps, 2 nylon lashing straps, 4 cable spacers	360889-000	FOSC-ACC-LASHING-STRAPS
•	•	•	•	•	1	Lashing strap	124063-000	FOSC-ACC-LASH-CBL-SUPPORT
•	•	•	•	•	5	2 hanger brackets and clamps, 2 lashing straps, ground wire	340883-000	FOSC-ACC-UNIV-AER-CL-NO6
•	•	•	•	•	1	1 set of ADSS hanger clamps, cable protection wrap	1B376P-000	FOSC-ACC-ADSSBRKT-400450
•	•	•	•	•	100	1 Snaplock* clamp	C85442-000	FOSC-ACC-SNAPLOCK-CLAMPS
PEDESTAL								
•	•	•	•	•	10	Universal pedestal bracket, Snaplock* clamp, associated hardware	F29601-000	FOSC-ACC-PED-BRKT-UNIV
POLE or WALL								
•	•	•	•	•	1	2 mounting brackets, 2 Snaplock* clamps, 4 lag bolts	C82508-000**	FOSC-ACC-WALL/POLE-MOUNT
•	•	•	•	•	1	2 mounting brackets, 4 Snaplock* clamps, 4 lag bolts	D80858-000	FOSC-ACC-WALL-PMT-BRKT
		•			1	Custom bracket components and hardware for mounting FOSC 450 B6 closure to pole	D91837-000	FOSC-ACC-MTGBKT-450-B6PL
			•		1	Custom bracket and hardware for mounting FOSC 450 D6 closure to pole.	919435-000	FOSC-ACC-D-POLE-MOUNT

*Snaplock is a trademark of Epicor Industries, Inc. **Commonly Requested Kits



360889-000



663259-000



124063-000



340883-000



A13909-000



F29601-000



1B376P-000



C82508-000



D80858-000



D91837-000



919435-000

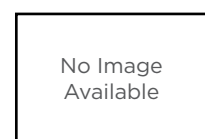

No Image Available

C85442-000

FOSC-OC Splitter



1 Tray Type

6	FOSC-A-TRAY-24, "Black Box" concept*
3	FOSC-D-TRAY-72

2 Splitter Type

A	A (fused biconical tapered)
P	P (standard planar technology)

3 Number of Integrated Splitters

Splitter/Grade	Tray Type			
	6		3	
	A	P	A	P
1x2	16		12	
2x2	16		9	
1x4		2		10
2x4		2		9
1x8		2		6
2x8		2		6
1x16		2		3
2x16		2		3
1x32		1		1
2x32		1		1
1x64				1
2x64				1

4 Number of Inputs per Splitter

1	1x...splitter
2	2x...splitter

6 Split Ratio

00	Symmetrical
05	5/95
10	10/90
15	15/85
20	20/80
25	25/75
30	30/70
35	35/65
40	40/60
45	45/55

Note: All asymmetrical split ratios are only available for 1x2 and 2x2 splitters.

5 Number of Outputs per Splitter

2	...x 2 splitter
3	...x 3 splitter
4	...x 4 splitter
6	...x 6 splitter
8	...x 8 splitter
G	...x 16 splitter
W	...x 32 splitter
Z	...x 64 splitter

*FOSC-A-Tray-24 fits A or B size closures.

The FOSC-OC-6 is a "black box" concept and therefore does not allow splicing the in- and outgoing fibers on this tray. Pre-installed tubes will route these fibers to another tray in the closure box

Field Installable Splitter

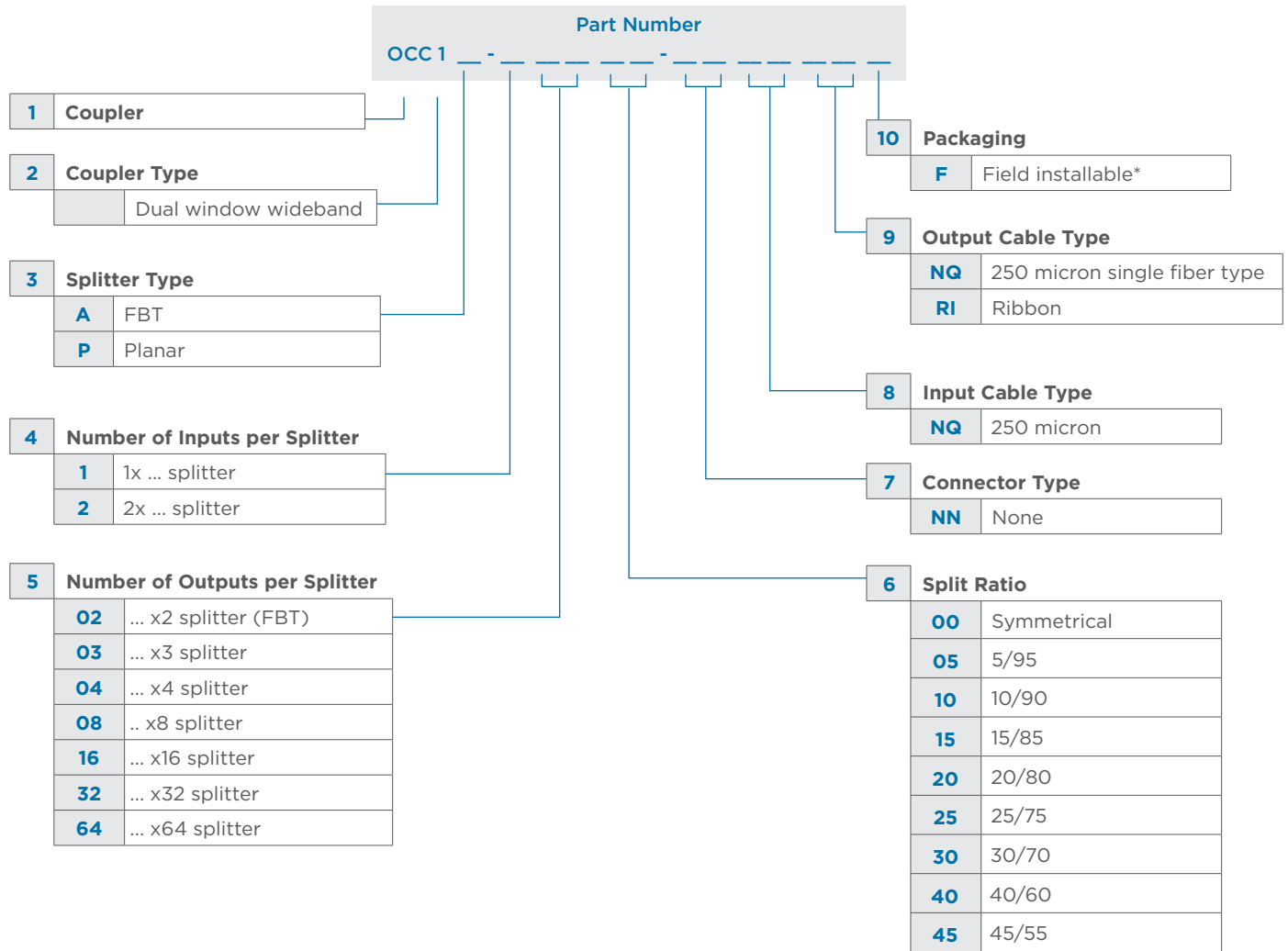

Note: All asymmetrical split ratios are only available for 1x2 and 2x2 splitters

*Standard fiber length = 2.5 + -0.5m at each side (non-connectorized)

Trays with Singlemode Wideband Couplers/Splitters

Trays come in a standard package of one.



FOSC OC Splitter

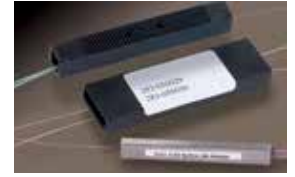

Field-installable Splitter

Tray Type**	Tray Capacity	Splitter Type	Detailed Description	Part Number	OC Splitter Kits Description
A	"Black Box"***	Grade A-Fused Biconical Tapered	2 - 1x2 splitter, symmetrical split ratio	5Z5944-000	FOSC-OC-6A21200
			6 - 1x2 splitter, symmetrical split ratio	BP7852-000	FOSC-OC-6A61200
			1 - 1x2 splitter, symmetrical split ratio	E45575-000	FOSC-OC-6A11200
			1 - 5x2 splitter, symmetrical split ratio	C74674-000	FOSC-OC-6A51200
		Planar	1 - 1x16 splitter, symmetrical split ratio	D39498-000	FOSC-OC-6P11G00
			1 - 2x16 splitter, symmetrical split ratio	C75701-000	FOSC-OC-6P12G00
			1 - 1x4 splitter, symmetrical split ratio	CC8177-000	FOSC-OC-6P11400
			1 - 1x8 splitter, symmetrical split ratio	CC1037-000	FOSC-OC-6P11800
			2 - 1x4 splitter, symmetrical split ratio	QK7510-000	FOSC-OC-6P21400
			2 - 1x8 splitter, symmetrical split ratio	WH6662-000	FOSC-OC-6P21800
D	72*	Grade A-Fused Biconical Tapered	1 - 1x2 splitter, symmetrical split ratio	C75768-000	FOSC-OC-3A11200
	72*	Planar	1 - 1x4 splitter, symmetrical split ratio	CB9820-000	FOSC-OC-3P11400
1 - 1x8 splitter, symmetrical split ratio			E49835-000	FOSC-OC-3P11800	
1 - 1x16 splitter, symmetrical split ratio			D39890-000	FOSC-OC-3P11G00	
1 - 1x32 splitter, symmetrical split ratio			F58883-000	FOSC-OC-3P11W00	
2 - 1x8 splitter, symmetrical split ratio			CB4800-000	FOSC-OC-3P21800	
2 - 1x16 splitter, symmetrical split ratio			C73000-000	FOSC-OC-3P21G00	
2 - 1x4 splitter, symmetrical split ratio			JH1234-000	FOSC-OC-3P21400	
		Grade A-Fused Biconical Tapered	1 - 1x2 FBT	CC8541-000	OCC1A-1200-NNNANQNF
Field Installable		Planar	1 - 1x4 planar	CC9545-000	OCC1P-10400-NNNQNQF
			1 - 1x8 planar	CC8542-000	OCC1P-10800-NNNQNQF
			1 - 1x16 planar	CC8544-000	OCC1P-11600-NNNQNQF
			1 - 1x32 planar	CC8312-000	OCC1P-13200-NNNQNQF
			1 - 1x64 planar	CC8313-000	OCC1P-16400-NNNQNQF
Field Installable		Planar - Ribbon	1 - 1x3 planar	754759-000	OCC1P-10300-NNNQRIF
			1 - 1x4 planar	367652-000	OCC1P-10400-NNNQRIF
			1 - 1x8 planar	121724-000	OCC1P-10800-NNNQRIF
			1 - 1x16 planar	414942-000	OCC1P-11600-NNNQRIF
			1 - 1x32 planar	891722-000	OCC1P-13200-NNNQRIF

*TE's SMOUV splice sleeves highly recommended for use with these trays/modules.

**A trays fit A or B-size closures.

FOSC-OC Coarse Wavelength Division Multiplexing in FOSC trays

Part Number

FOSC-OC - - - -

Tray Type

3	FOSC-D-TRAY-72: splice modules in the middle of the tray
6	FOSC-A-TRAY-24: "black box" concept
7	2 unit high FOSC-D tray with 12 connector patchpanel
8	1 unit high FOSC-D tray with 6 connector patchpanel

Coarse WDM Components

Number of Channels

1	1
2	2
4	4
8	8
A	4 channels + upgrade port
B	8 channels + upgrade port
C	4 channels + upgrade + 1310 nm port
D	8 channels + upgrade + 1310 nm port
E	4 channels + 1310 nm port
F	8 channels + 1310 nm port
G	12 channels
H	2 channels + upgrade
I	2 channels + upgrade + 1310 nm port
J	5 channels + upgrade + 1310 nm port
K	5 channels + upgrade
L	3 channels + upgrade
M	6 channels + upgrade + 1310 port
N	10 channels
O	18 channels
P	11 channels
R	1 channel + upgrade
S	16 channels
T	6 channels + upgrade
U	2 channels + 1310 port
V	1 channel + upgrade + 1310 port
W	10 channels + upgrade + 1310 port

Options

T	Test fiber
2T	Tx and Rx test fibers

Connector Type

SC	LC	Min.return loss
S1	L1	50 dB (UPC)*
S2	L2	60 dB (APC 8°)*
S3		60 dB (APC 9°)*
NN		Not applicable

*UPC Ultra polished physical contact
*APC Angled polished physical contact

Channel Spacing/Sequence

0	0 One channel only
1	20 nm e.g. 1471, 1491, 1511,...
2	40 nm e.g. 1471, 1511, 1551,...
3	20 nm + 1310 nm
4	20 nm + upgrade port
5	20 nm + upgrade port + 1310 nm
A	Channels skipped

Starting Wavelength

27	27 1271 nm
29	29 1291 nm
•	•
•	•
•	•
•	•
•	•
61	61 1611 nm

Type

M	Multiplexing
D	Demultiplexing
X	Double demux (for 2 fiber system)
Y	Double mux (for 2 fiber system)
Z	Triple mux

PERFORMANCE SPECIFICATIONS

Refer to the TE CWDM specification proposal 5336.

Notes

- Refer to the Closure Capacities and Characteristics section for tray dimensions.
- The FOSC-OC-3 tray has been provided with holders for heat-shrinkable splice protectors to splice the incoming fibers.
- The FOSC-OC-6 is a black box concept and therefore does not allow splicing the in- and outgoing fibers on this tray. Pre-installed tubes will route these fibers to another tray in the enclosure.
- The FOSC-OC-7 and FOSC-OC-8 provide pre-terminated in- and outputs of the CWDM. Outside plant fibers can be spliced on a standard FOSC tray to 900 micron pigtails and be routed to the CWDM tray.
- Not all configurations are possible. Please consult your local sales engineer for confirmation.

Field Installable CWDM

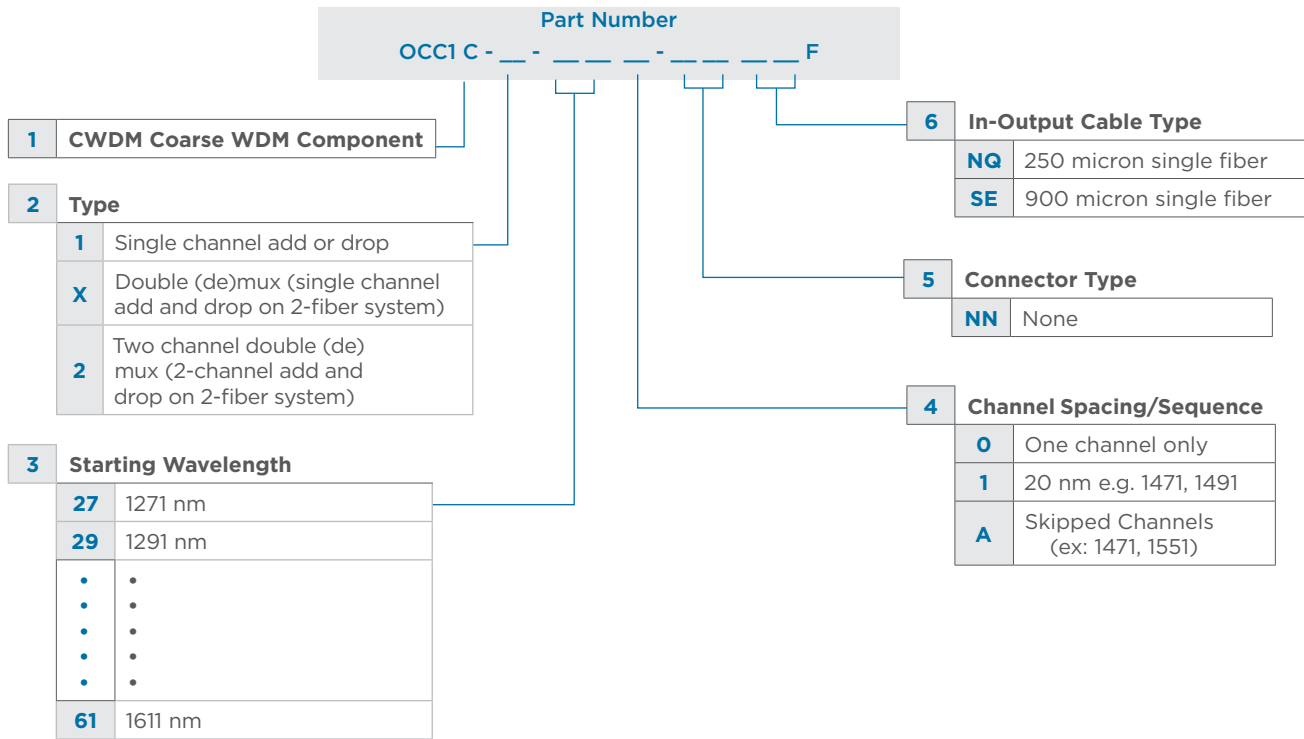
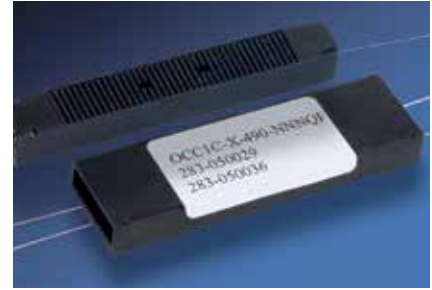

Trays with Coarse Wavelength Division Multiplexing/DeMultiplex Components (CWDM)

Detailed Description	Number of Channels	Upgrade Port	1310	Part Number	Description
Tray Type: A**; Tray Capacity: "Black Box"					
Double Demux 1471 nm	1	X		E1566C-000	FOSC-OC-6C1X470NN-US26A
Double Demux 1511 nm	1	X		G4682T-000	FOSC-OC-6C1X510NN-US26A
Demux 1431 - 1451 nm	2	X		CS1033-000	FOSC-OC-6CHD431NN-US26
Demux 1471 - 1491 nm	2	X		CS1029-000	FOSC-OC-6CHD471NN-US26
Demux 1511 - 1531 nm	2	X		CS1030-000	FOSC-OC-6CHD511NN-US26
Demux 1551 - 1571 nm	2	X		CS1031-000	FOSC-OC-6CHD551NN-US26
Demux 1591 - 1611 nm	2	X		CS1032-000	FOSC-OC-6CHD591NN-US26
Double Demux 1471 - 1491 nm	2	X		CK9319-000	FOSC-OC-6CHX471NN-US26A
Double Demux 1511 - 1531 nm	2	X		CK9320-000	FOSC-OC-6CHX571NN-US26A
Demux 1471 - 1531 nm	4	X		CK4768-000	FOSC-OC-6CAD471NN-US26A
Demux 1551 - 1611nm	4	X		CK4769-000	FOSC-OC-6CAD551NN-US26A
Demux 1471 - 1611 nm	8	X		CP1551-000	FOSC-OC-6CFD471NN-US26
Double Demux 1471 - 1531 nm	4	X		CC9309-000	FOSC-OC-6CAX471NN-US26
Double Demux 1551 - 1610 nm	4	X		CC9310-000	FOSC-OC-6CAX551NN-US26
Tray Type: D*; Tray Capacity: 72*					
Demux 1551 - 1611 nm	4	X		CC6143-000	FOSC-OC-3CAD551NN
Double Demux 1471 - 1531 nm	4	X		CC8944-000	FOSC-OC-3CAX471NN-US26
Demux 1471 - 1611 nm	8		X	CC4896-000	FOSC-OC-3CFD471NN-US26

*TE's SMOUV splice sleeves highly recommended for use with these trays/modules.

**A trays fit A or B-size closures.

Field Installable CWDM - 1 and 2 Channels

Detailed Description Tray Type: N/A; Tray Capacity: N/A	Number of Channels	Upgrade Port	Part Number	Description
1 CH Double Demux 1431 nm	1	X	CP5771-000	OCC1C-X-430-NNNQF-US26
1 CH Double Demux 1451 nm	1	X	CP5772-000	OCC1C-X-450-NNNQF-US26
1 CH Double Demux 1471 nm	1	X	CP5773-000	OCC1C-X-470-NNNQF-US26
1 CH Double Demux 1491 nm	1	X	CP5774-000	OCC1C-X-490-NNNQF-US26
1 CH Double Demux 1511 nm	1	X	CP5775-000	OCC1C-X-510-NNNQF-US26
1 CH Double Demux 1531 nm	1	X	CP5776-000	OCC1C-X-530-NNNQF-US26
1 CH Double Demux 1551 nm	1	X	CP5777-000	OCC1C-X-550-NNNQF-US26
1 CH Double Demux 1571 nm	1	X	CP5779-000	OCC1C-X-570-NNNQF-US26
1 CH Double Demux 1591 nm	1	X	CP5780-000	OCC1C-X-590-NNNQF-US26
1 CH Double Demux 1611 nm	1	X	CP5781-000	OCC1C-X-610-NNNQF-US26
2 CH Double Demux 1471 - 1491 nm	2	X	CC9377-000	OCC1C-2-X471-NNNQF-US26
2 CH Double Demux 1511 - 1531 nm	2	X	CC9378-000	OCC1C-2-X511-NNNQF-US26
2 CH Double Demux 1531 - 1551 nm	2	X	CR9646-000	OCC1C-2-X531-NNNQF-US26
2 CH Double Demux 1551 - 1571 nm	2	X	CC9379-000	OCC1C-2-X551-NNNQF-US26
2 CH Double Demux 1591 - 1611 nm	2	X	CC9380-000	OCC1C-2-X591-NNNQF-US26
2 CH Double Demux 1310 - 1551 nm	2	X	CC9381-000	OCC1C-2-X31A-NNNQF-US26

*TE's SMOUV splice sleeves are highly recommended for use with these trays/modules. Note: One tray kit per package.

Compact Field Installable CWDM

PERFORMANCE SPECIFICATIONS

Refer to the TE Connectivity CWDM specification proposal 5414.

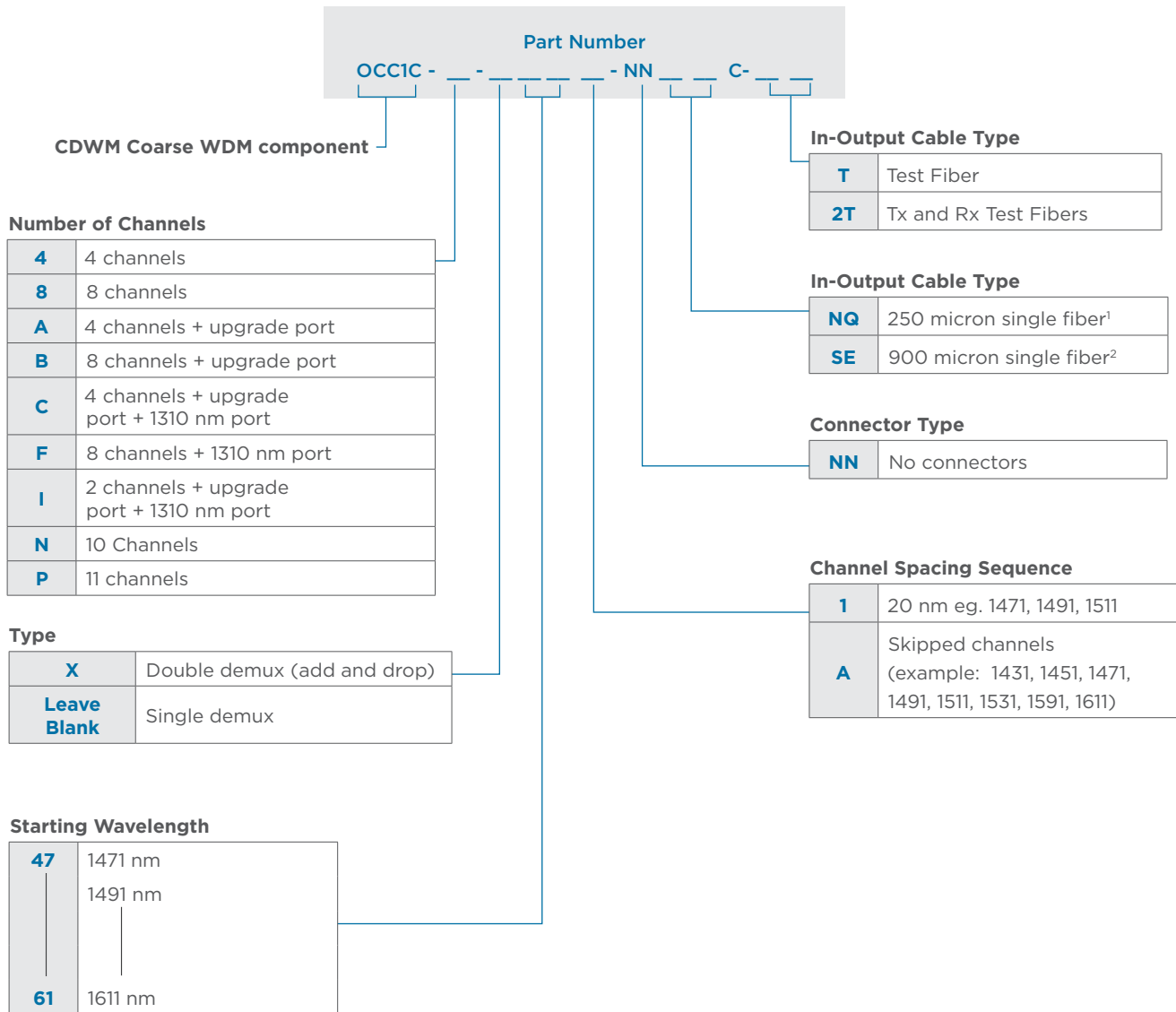

Example:

OCC1C-A-X471-NNNQ

4 channel compact CWDM, double demux with upgrade port, not connectorized, 1471-1611 nm, 250 μ fibers

¹ Available with colored fibers for select wavelengths per TE color code

² Available with colored fibers for select wavelengths per customer request

Compact Field Installable CWDM

Detailed Description	Number of Channels	Part Number	Description
Tray Type: N/A; Tray Capacity: N/A			
4CH Single Demux, 250 Micron, 1511-1571 nm	4	R66521-000	OCC1C-4-511-NNNQC-US26
8CH Single Demux, 250 Micron, 1471-1611 nm	8	798561-000	OCC1C-8-471-NNNQC
4CH Single Demux, Upgrade, 250 Micron, 1431-1491 nm	4	768727-000	OCC1C-A-431-NNNQC-US23
4CH Single Demux, Upgrade, 250 Micron, 1471-1531 nm	4	3T5187-000	OCC1C-A-471-NNNQC-US26
4CH Single Demux, Upgrade, 900 Micron, 1471-1531 nm	4	T18616-000	OCC1C-A-471-NNSEC-US26
4CH Single Demux, Upgrade, 250 Micron, 1511, 1571, 1591, 1611 nm	4	672134-000	OCC1C-A-51A-NNNQC-US23
4CH Single Demux, Upgrade, 250 Micron, 1551-1611 nm	4	23416D-000	OCC1C-A-551-NNNQC-US26
4CH Single Demux, Upgrade, 900 Micron, 1551-1611 nm	4	53693P-000	OCC1C-A-551-NNSEC-US26
4CH Double Demux, Upgrade, 250 Micron, 1471-1531 nm	4	38244Z-000	OCC1C-A-X471-NNNQC-US26
4CH Double Demux, Upgrade, 250 Micron, 1551-1611 nm	4	584135-000	OCC1C-A-X551-NNNQC-US26
8CH Single Demux, Upgrade, 250 Micron, 1431-1531, 1591-1611 nm	8	JM3297-000	OCC1C-B-43A-NNNQC-US23
8CH Single Demux, Upgrade, 250 Micron, 1431-1511, 1571-1611 nm	8	885217-000	OCC1C-B-43A-NNNQC-US23C
8CH Single Demux, Upgrade, 900 Micron, 1431-1511, 1571-1611 nm	8	376744-000	OCC1C-B-43A-NNSEC-C01
8CH Single Demux, Upgrade, 250 Micron, 1471-1611 nm	8	G52146-000	OCC1C-B-471-NNNQC-US23
8CH Single Demux, Upgrade, 1431-1531 only, 250 Micron, 1471 - 1611 nm	8	G5929Y-000	OCC1C-B-471-NNNQC-US26
8CH Single Demux, Upgrade, 1431-1451 only, 900 Micron, 1471-1611 nm	8	TP1579-000	OCC1C-B-471-NNSEC-US26
4CH Single Demux, Upgrade, 1310, 250 Micron, 1471-1531 nm	4	M63669-000	OCC1C-C-471-NNNQC-US26
4CH Single Demux, Upgrade, 1310, 900 Micron, 1471-1531 nm	4	251842-000	OCC1C-C-471-NNSEC-US26
4CH Single Demux, Upgrade, 1310, 250 Micron, 1551-1611 nm	4	V35741-000	OCC1C-C-551-NNNQC-US26
4CH Single Demux, Upgrade, 1310, 900 Micron, 1551-1611 nm	4	365734-000	OCC1C-C-551-NNSEC-US26
8CH Single Demux, Upgrade, 1310, Test Port, 250 Micron, 1431-1511, 1571-1611 nm	8	693489-000	OCC1C-D-43A-NNNQC-T-U45A
8CH Single Demux, Upgrade, 1310, 900 Micron, 1431-1511, 1571-1611 nm	8	668264-000	OCC1C-D-43A-NNSEC-US26
8CH Single Demux, 1310, Tx and Rx Test Ports, 250 Micron, 1471-1611 nm	8	983648-000	OCC1C-F-471-NNNQC-2T-U26
8CH Single Demux, 1310, Tx and Rx Test Ports, 250 Micron, 1471-1611 nm	4	961898-000	OCC1C-F-471-NNNQC-2T-U41
8CH Single Demux, 1310, 250 Micron, 1471-1611 nm	8	8X4939-000	OCC1C-F-471-NNNQC-US26
8CH Single Demux, 1310, 900 Micron, 1471-1611 nm	8	R34325-000	OCC1C-F-471-NNSEC-US26
2CH Single Demux, Upgrade, 1310, 250 Micron, 1431-1451 nm	2	H36214-000	OCC1C-I-431-NNNQC-US26
2CH Single Demux, Upgrade, 1310, 250 Micron, 1471-1491 nm	2	198632-000	OCC1C-I-471-NNNQC-US26
2CH Single Demux, Upgrade, 1310, 250 Micron, 1511-1531 nm	2	336114-000	OCC1C-I-511-NNNQC-US26
2CH Single Demux, Upgrade, 1310, 250 Micron, 1551-1571 nm	2	783714-000	OCC1C-I-551-NNNQC-US26
2CH Single Demux, Upgrade, 1310, 250 Micron, 1591-1611 nm	2	966965-000	OCC1C-I-591-NNNQC-US26
2CH Double Demux, Upgrade, 1310, 250 Micron, 1591-1611 nm	2	816989-000	OCC1C-I-X591-NNNQC-US26
10CH Single Demux, 1310, 250 Micron, 1431-1611 nm	10	866716-000	OCC1C-N-433-NNNQC-US26
11CH Single Demux, 250 Micron, 1311, 1431-1611 nm	11	J4198V-000	OCC1C-P-43A-NNNQC-US26

ORDERING INFORMATION

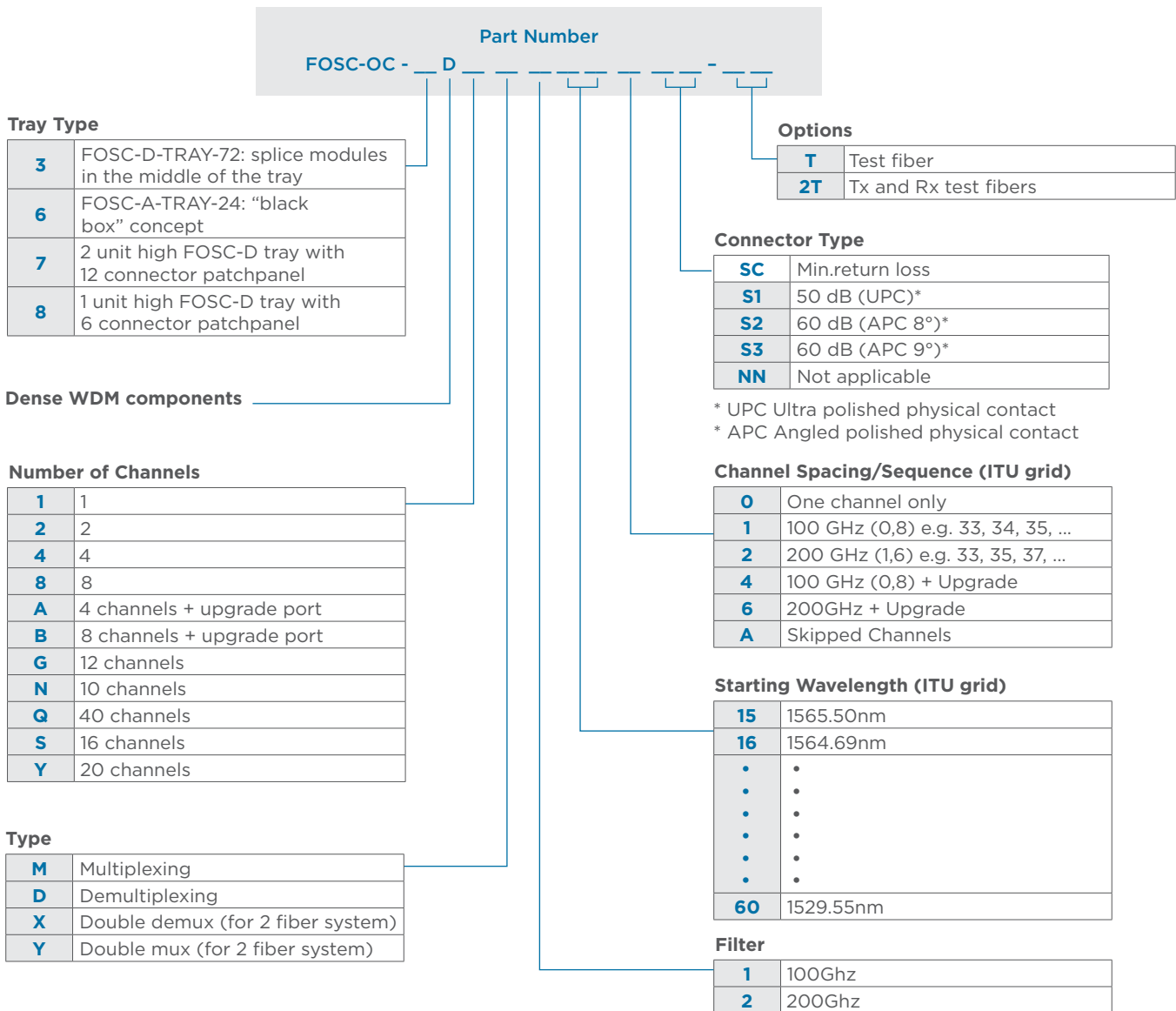

PERFORMANCE SPECIFICATIONS

Refer to the TE DWDM specification proposal 5400.

Notes

- Refer to the FOSC trays ordering guide for tray dimensions.
- The FOSC-OC-3 tray has been provided with holders for heat-shrinkable splice protectors to splice the incoming fibers.
- The FOSC-OC-6 is a black box concept and therefore does not allow splicing the in- and outgoing fibers on this tray. Pre-installed tubes will route these fibers to another tray in the enclosure.
- The FOSC-OC-7 and FOSC-OC-8 provide pre-terminated in- and outputs of the DWDM. Outside plant fibers can be spliced on a standard FOSC tray to 900 micron pigtailed and be routed to the DWDM tray.
- Not all configurations are possible. Please consult your local sales engineer for confirmation.

Trays with Dense Wavelength Division Multiplexing/Demultiplexing Components (DWDM)

Detailed Description	Number of Channels	Part Number	Description
Tray Type: A			
4CH Single Demux, Upgrade, Express, Tx and Rx Test Ports, 20 - 23 nm	4	233732-000	FOSC-OC-6DAD1201NN2T-U23
4CH Single Demux, Upgrade, Express, Tx and Rx Test Ports, 21 - 24 nm	4	418552-000	FOSC-OC-6DAD1211NN2T-U23
4CH Single Demux, Upgrade, Express, Tx and Rx Test Ports, 24 - 27 nm	4	522619-000	FOSC-OC-6DAD1241NN2T-U23
4CH Single Demux, Upgrade, Express, Tx and Rx Test Ports, 28 - 31 nm	4	356391-000	FOSC-OC-6DAD1281NN2T-U23
4CH Single Demux, Upgrade, Express, Tx and Rx Test Ports, 32 - 35 nm	4	522277-000	FOSC-OC-6DAD1321NN2T-U23
4CH Single Demux, Upgrade, Express, Tx and Rx Test Ports, 36 - 39 nm	4	453481-000	FOSC-OC-6DAD1361NN2T-U23
4CH Single Demux, Upgrade, Express, Tx and Rx Test Ports, 40 - 43 nm	4	536725-000	FOSC-OC-6DAD1401NN2T-U23
4CH Single Demux, Upgrade, Express, Tx and Rx Test Ports, 44 - 47 nm	4	259645-000	FOSC-OC-6DAD1441NN2T-U23
4CH Single Demux, Upgrade, Express, Tx and Rx Test Ports, 48 - 51 nm	4	289162-000	FOSC-OC-6DAD1481NN2T-U23
4CH Single Demux, Upgrade, Express, Tx and Rx Test Ports, 52 - 55 nm	4	326145-000	FOSC-OC-6DAD1521NN2T-U23
4CH Single Demux, Upgrade, Express, Tx and Rx Test Ports, 56 - 59 nm	4	287626-000	FOSC-OC-6DAD1561NN2T-U23
4CH Double Demux, Upgrade, Express, Tx and Rx Test Ports, 20 - 23 nm	4	775788-000	FOSC-OC-6DAX1204NN2T-U23
4CH Double Demux, Upgrade, Express, Tx and Rx Test Ports, 24 - 27 nm	4	697576-000	FOSC-OC-6DAX1244NN2T-U23
4CH Double Demux, Upgrade, Express, Tx and Rx Test Ports, 28 - 31 nm	4	899651-000	FOSC-OC-6DAX1284NN2T-U23
4CH Double Demux, Upgrade, Express, Tx and Rx Test Ports, 32 - 35 nm	4	876696-000	FOSC-OC-6DAX1324NN2T-U23
4CH Double Demux, Upgrade, Express, Tx and Rx Test Ports, 36 - 39 nm	4	537225-000	FOSC-OC-6DAX1364NN2T-U23
4CH Double Demux, Upgrade, Express, Tx and Rx Test Ports, 40 - 43 nm	4	256329-000	FOSC-OC-6DAX1404NN2T-U23
4CH Double Demux, Upgrade, Express, Tx and Rx Test Ports, 44 - 47 nm	4	716946-000	FOSC-OC-6DAX1444NN2T-U23
4CH Double Demux, Upgrade, Express, Tx and Rx Test Ports, 48 - 51 nm	4	554948-000	FOSC-OC-6DAX1484NN2T-U23
4CH Double Demux, Upgrade, Express, Tx and Rx Test Ports, 52 - 55 nm	4	378146-000	FOSC-OC-6DAX1524NN2T-U23
4CH Double Demux, Upgrade, Express, Tx and Rx Test Ports, 56 - 59 nm	4	653499-000	FOSC-OC-6DAX1564NN2T-U23
8CH Single Demux, Upgrade, 20 - 27 nm	8	338861-000	FOSC-OC-6DBD1201NN
8CH Single Demux, Upgrade, Express, Tx and Rx Test Ports, 20 - 27 nm	8	DD6594-000	FOSC-OC-6DBD1201NN2T-U23
8CH Single Demux, Upgrade, Express, 20 - 27 nm	8	954395-000	FOSC-OC-6DBD1204NN-US26
8CH Single Demux, Upgrade, 23, 25, 27 - 37 nm	8	975473-000	FOSC-OC-6DBD1232NN
8CH Single Demux, Upgrade, 23, 25, 27, 29, 39, 41, 43, 45 nm	8	271474-000	FOSC-OC-6DBD123ANN-US21
8CH Single Demux, Upgrade, Express, Tx and Rx Test Ports, 25 - 32 nm	8	B56232-000	FOSC-OC-6DBD1251NN2T-U23
8CH Single Demux, Upgrade, 28 - 35 nm	8	783214-000	FOSC-OC-6DBD1281NN
8CH Single Demux, Upgrade, Express, Tx and Rx Test Ports, 28 - 35 nm	8	B48787-000	FOSC-OC-6DBD1281NN2T-U23
8CH Single Demux, Upgrade, Express, 28 - 35 nm	8	235784-000	FOSC-OC-6DBD1284NN-US26
8CH Single Demux, Upgrade, Express, Tx and Rx Test Ports, 33 - 40 nm	8	352211-000	FOSC-OC-6DBD1331NN2T-U23
8CH Single Demux, Upgrade, Express, Tx and Rx Test Ports, 34 - 41 nm	8	784987-000	FOSC-OC-6DBD1341NN2T-U23
8CH Single Demux, Upgrade, 36 - 43 nm	8	361675-000	FOSC-OC-6DBD1361NN
8CH Single Demux, Upgrade, Express, Tx and Rx Test Ports, 36 - 43 nm	8	784299-000	FOSC-OC-6DBD1361NN2T-U23
8CH Single Demux, Upgrade, Express, 36 - 43 nm	8	649712-000	FOSC-OC-6DBD1364NN-US26

Trays with Dense Wavelength Division Multiplexing/Demultiplexing Components (DWDM)

Detailed Description	Number of Channels	Part Number	Description
Tray Type: A			
8CH Single Demux, Upgrade, 44 - 51 nm	8	548889-000	FOSC-OC-6DBD1441NN
8CH Single Demux, Upgrade, Express, Tx and Rx Test Ports, 44 - 51 nm	8	778497-000	FOSC-OC-6DBD1441NN2T-U23
8CH Single Demux, Upgrade, 52 - 59 nm	8	743794-000	FOSC-OC-6DBD1521NN
8CH Single Demux, Upgrade, Express, Tx and Rx Test Ports, 52 - 59 nm	8	656598-000	FOSC-OC-6DBD1521NN2T-U23
8CH Double Demux, Upgrade, Express, Tx and Rx Test Ports, 20 - 27 nm	8	689578-000	FOSC-OC-6DBX1204NN2T-U23
8CH Double Demux, Upgrade, Express, Test Ports, Tx 21, 22, 24, 26, 28, 33, 36, 39; Rx 38, 41, 35, 42, 46, 49, 34, 32 nm	8	244284-000	FOSC-OC-6DBX121ANN2T-U23
8CH Double Demux, Upgrade, Express, Tx and Rx Test Ports, 28 - 35 nm	8	265994-000	FOSC-OC-6DBX1284NN2T-U23
8CH Double Demux, Upgrade, Express, Tx and Rx Test Ports, 36 - 43 nm	8	535664-000	FOSC-OC-6DBX1364NN2T-U23
8CH Double Demux, Upgrade, Express, Tx and Rx Test Ports, 44 - 51 nm	8	562886-000	FOSC-OC-6DBX1444NN2T-U23
8CH Double Demux, Upgrade, Express, Tx and Rx Test Ports, 52 - 59 nm	8	529839-000	FOSC-OC-6DBX1524NN2T-U23
12CH Single Demux, Upgrade, Express, Tx and Rx Test Ports, 20 - 31 nm	12	129752-000	FOSC-OC-6DGD1204NN2T-U23
12CH Single Demux, Upgrade, Express, Tx and Rx Test Ports, 50 - 61 nm	12	31565W-000	FOSC-OC-6DGD1504NN2T-U23
16CH Single Demux, Upgrade, Express, Tx and Rx Test Ports, 20 - 35 nm	16	929218-000	FOSC-OC-6DSD1204NN2T-U23
16CH Single Demux, Upgrade, Express, Tx and Rx Test Ports, 25 - 40 nm	16	59684T-000	FOSC-OC-6DSD1254NN2T-U23
20CH Single Demux, Upgrade, Express, Tx and Rx Test Ports, 20 - 39 nm	20	66873J-000	FOSC-OC-6DYD1204NN2T-U23
20CH Single Demux, Upgrade, Express, Tx and Rx Test Ports, 40 - 59 nm	20	A19691-000	FOSC-OC-6DYD1404NN2T-U23
40CH Single Demux, Upgrade, Express, Tx and Rx Test Ports, 20 - 59 nm	40	988743-000	FOSC-OC-6DQD1204NN2T-U23
5 Band BWDM Single Demux, Express, Tx and Rx Test Ports, 20 - 59 nm	40	539449-000	FOSC-OC-6D5B20ANN2T-U23
5 Band BWDM Double Demux, Express, Tx and Rx Test Ports, 20 - 59 nm	40	989184-000	FOSC-OC-6D5BX20ANN2T-U23
10 Band BWDM Single Demux, Express, Tx and Rx Test Ports, 20 - 59 nm	40	367979-000	FOSC-OC-6DNDB20ANN2T-U23
10 Band BWDM Double Demux, Express, Tx and Rx Test Ports, 20 - 59 nm	40	224482-000	FOSC-OC-6DNXB20ANN2T-U23
Tray Type: D			
4CH Single Demux, Upgrade, 21, 23, 25, 27 nm	4	DG9676-000	FOSC-OC-3DAD1212NN
4CH Single Demux, Upgrade, 29, 31, 33, 35 nm	4	R46569-000	FOSC-OC-3DAD1292NN
8CH Single Demux, Upgrade, Express, 20 - 27 nm	8	768626-000	FOSC-OC-3DBD1204NN-US26
8CH Single Demux, Upgrade, 21, 23, 25 - 35 nm	8	G35247-000	FOSC-OC-3DBD1212NN
8CH Single Demux, Upgrade, 39, 41, 43 - 53 nm	8	J25147-000	FOSC-OC-3DBD1392NN
16CH Single Demux, Upgrade, 23, 25, 27 - 53 nm	16	967122-000	FOSC-OC-3DSD1237NN-US21
40CH Single Demux, Upgrade, Express, Tx and Rx Test Ports, 20 - 59 nm	40	39862W-000	FOSC-OC-3DQD1204NN2T-U23

FOSC 450

OCC1D - Field Installable DWDM

ORDERING INFORMATION

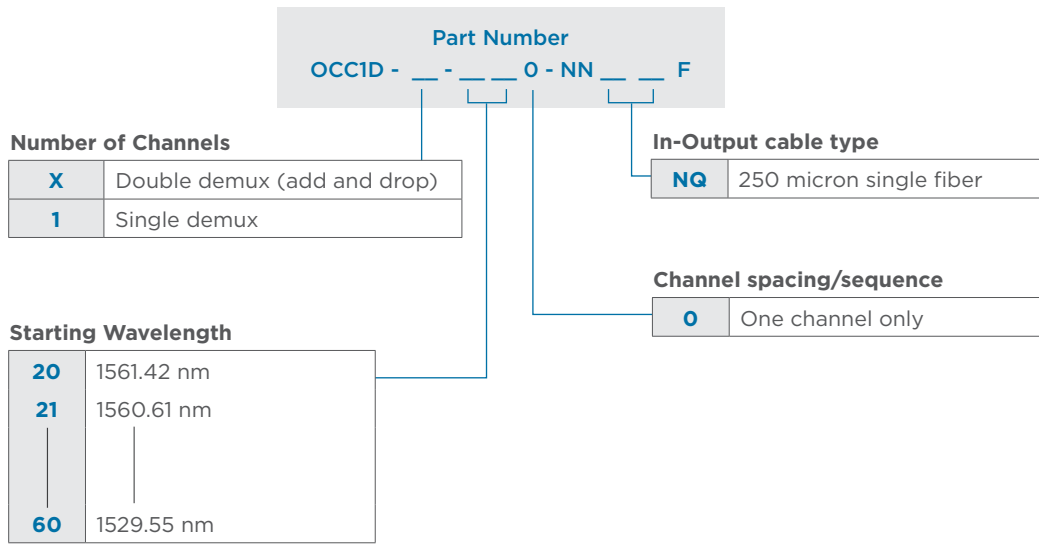

DWDM

Detailed Description	Number of Channels	Part Number	Description
Tray Type: N/A; Tray Capacity: N/A			
1 CH Double Demux 20 nm	1	R32159-000	OCC1D-X-200-NNNQF
1 CH Double Demux 21 nm	1	T63574-000	OCC1D-X-210-NNNQF
1 CH Double Demux 22 nm	1	E31478-000	OCC1D-X-220-NNNQF
1 CH Double Demux 23 nm	1	B57410-000	OCC1D-X-230-NNNQF
1 CH Double Demux 24 nm	1	A68521-000	OCC1D-X-240-NNNQF
1 CH Double Demux 25 nm	1	J35412-000	OCC1D-X-250-NNNQF
1 CH Double Demux 26 nm	1	H68521-000	OCC1D-X-260-NNNQF
1 CH Double Demux 27 nm	1	R68752-000	OCC1D-X-270-NNNQF
1 CH Double Demux 28 nm	1	J96321-000	OCC1D-X-280-NNNQF
1 CH Double Demux 29 nm	1	R74129-000	OCC1D-X-290-NNNQF
1 CH Double Demux 30 nm	1	F63215-000	OCC1D-X-300-NNNQF
1 CH Double Demux 31 nm	1	L63215-000	OCC1D-X-310-NNNQF
1 Ch Double Demux 32 nm	1	K69850-000	OCC1D-X-320-NNNQF
1 CH Double Demux 33 nm	1	J63987-000	OCC1D-X-330-NNNQF
1 CH Double Demux 34 nm	1	R96882-000	OCC1D-X-340-NNNQF
1 CH Double Demux 35 nm	1	R32650-000	OCC1D-X-350-NNNQF
1 CH Double Demux 36 nm	1	R74125-000	OCC1D-X-360-NNNQF
1 CH Double Demux 37 nm	1	V68741-000	OCC1D-X-370-NNNQF
1 CH Double Demux 38 nm	1	R69312-000	OCC1D-X-380-NNNQF
1 CH Double Demux 39 nm	1	V95478-000	OCC1D-X-390-NNNQF
1 CH Double Demux 40 nm	1	B35216-000	OCC1D-X-400-NNNQF

DWDM (continued)

Detailed Description	Number of Channels	Part Number	Description
Tray Type: N/A; Tray Capacity: N/A			
1 CH Double Demux 41 nm	1	T58874-000	OCC1D-X-410-NNNQF
1 CH Double Demux 42 nm	1	K98521-000	OCC1D-X-420-NNNQF
1 CH Double Demux 43 nm	1	JK9632-000	OCC1D-X-430-NNNQF
1 CH Double Demux 44 nm	1	M63215-000	OCC1D-X-440-NNNQF
1 CH Double Demux 45 nm	1	552120-000	OCC1D-X-450-NNNQF
1 CH Double Demux 46 nm	1	TH8547-000	OCC1D-X-460-NNNQF
1 CH Double Demux 47 nm	1	R55412-000	OCC1D-X-470-NNNQF
1 CH Double Demux 48 nm	1	322369-000	OCC1D-X-480-NNNQF
1 CH Double Demux 49 nm	1	BC7441-000	OCC1D-X-490-NNNQF
1 CH Double Demux 50 nm	1	T74441-000	OCC1D-X-500-NNNQF
1 CH Double Demux 51 nm	1	V63332-000	OCC1D-X-510-NNNQF
1 CH Double Demux 52 nm	1	B63339-000	OCC1D-X-520-NNNQF
1 CH Double Demux 53 nm	1	E33984-000	OCC1D-X-530-NNNQF
1 CH Double Demux 54 nm	1	C63154-000	OCC1D-X-540-NNNQF
1 CH Double Demux 55 nm	1	C96541-000	OCC1D-X-550-NNNQF
1 CH Double Demux 56 nm	1	C78825-000	OCC1D-X-560-NNNQF
1 CH Double Demux 57 nm	1	D63214-000	OCC1D-X-570-NNNQF
1 CH Double Demux 58 nm	1	CC7744-000	OCC1D-X-580-NNNQF
1 CH Double Demux 59 nm	1	DC9926-000	OCC1D-X-590-NNNQF
1 CH Double Demux 60 nm	1	E85214-000	OCC1D-X-600-NNNQF

Detailed Description	Number of Channels	Part Number	Description
FOSC450 B with Integrated CWDM Trays			
O-BAND 2X2, 1291, 1293, 1471, 1491 nm	4	546515-000	FOSC450-6CAD29ANN2T-US26
O-BAND 4X4, 1291, 1293, 1295, 1290, 1471, 1491, 1591, 1611 nm	8	228629-000	FOSC450-6CBD29ANN2T-US26
8CH Single CWDM + Express + 2 Test Ports, 1431 - 1531, 1591, 1611 nm	8	ER3584-000	FOSC450-6CBC43ANN2T-US23
8CH Dual CWDM + Express + 2 Test Ports, 1431 - 1531, 1591, 1611 nm	8	EK3574-000	FOSC450-6CBX43ANN2T-US23
8CH Dual CWDM + Express + 2 Test Ports, 1471 - 1611 nm	8	893871-000	FOSC450-6CBX471NN2T-US23
FOSC450 D with Integrated DWDM Trays			
40CH Single DWDM + Upgrade + Express + 2 Test Ports, 20 - 59 nm	40	68358K-000	FOSC450-3DQD1204NN2T-U23
40CH Dual DWDM + Upgrade + Express + 2 Test Ports, 20 - 59 nm	40	634946-000	FOSC450-3DQX1204NN2T-U23
FOSC450 B with Integrated DWDM Trays			
8CH Single DWDM + Upgrade + Express + 2 Test Ports, 20-27 nm	8	28618Y-000	FOSC450-6DBD1201NN2T-US23
8CH Single DWDM + Upgrade + Express + 2 Test Ports, 25-32 nm	8	15113K-000	FOSC-450-6DBD1251NN2T-U23
8CH Single DWDM + Upgrade + Express + 2 Test Ports, 28 - 35 nm	8	18852D-000	FOSC450-6DBD1281NN2T-U23
8CH Single DWDM + Upgrade + Express + 2 Test Ports, 33 - 40 nm	8	31657C-000	FOSC450-6DBD1331NN2T-U23
8CH Single DWDM + Upgrade + Express + 2 Test Ports, 36 - 43 nm	8	268144-000	FOSC450-6DBD1361NN2T-U23
8CH Single DWDM + Upgrade + Express + 2 Test Ports, 44 - 51 nm	8	539582-000	FOSC450-6DBD1441NN2T-U23
8CH Single DWDM + Upgrade + Express + 2 Test Ports, 52 - 59 nm	8	537426-000	FOSC450-6DBD1521NN2T-U23
8CH Dual DWDM + Upgrade + Express + 2 Test Ports, 20 - 27 nm	8	H54959-000	FOSC450-6DBX1201NN2T-U23
8CH Dual DWDM + Upgrade + Express + 2 Test Ports, 25 - 32 nm	8	496598-000	FOSC450-6DBX1251NN2T-U23
8CH Dual DWDM + Upgrade + Express + 2 Test Ports, 28 - 35 nm	8	T76555-000	FOSC450-6DBX1281NN2T-U23
8CH Dual DWDM + Upgrade + Express + 2 Test Ports, 33 - 40 nm	8	9F1283-000	FOSC450-6DBX1331NN2T-U23
8CH Dual DWDM + Upgrade + Express + 2 Test Ports, 36 - 43 nm	8	R97641-000	FOSC450-6DBX1361NN2T-U23
8CH Dual DWDM + Upgrade + Express + 2 Test Ports, 44 - 51 nm	8	R56475-000	FOSC450-6DBX1441NN2T-U23
8CH Dual DWDM + Upgrade + Express + 2 Test Ports, 52 - 59 nm	8	E63589-000	FOSC450-6DBX1521NN2T-U23
12CH Single DWDM + Upgrade + Express + 2 Test Ports, 50 - 61 nm	12	574488-000	FOSC450-6DGD1504NN2T-U23
12CH Dual DWDM + Upgrade + Express + 2 Test Ports, 50 - 61 nm	12	384493-000	FOSC450-6DGX1504NN2T-U23
16CH Single DWDM + Upgrade + Express + 2 Test Ports, 25 - 40 nm	16	821169-000	FOSC450-6DSD1254NN2T-U23
16CH Dual DWDM + Upgrade + Express + 2 Test Ports, 25 - 40 nm	16	641414-000	FOSC450-6DSX1254NN2T-U23
20CH Single DWDM + Upgrade + Express + 2 Test Ports, 20 - 39 nm	20	15222Q-000	FOSC450-6DYD1204NN2T-U23
20CH Single DWDM + Upgrade + Express + 2 Test Ports, 40 - 59 nm	20	267742-000	FOSC450-6DYD1404NN2T-U23
40CH Single DWDM + Upgrade + Express + 2 Test Ports, 20 - 59 nm	40	96128F-000	FOSC450-6DQD1204NN2T-U23
FOSC450 B with Integrated BWDM Trays			
5 BAND Single BWDM + Express + 2 Test Ports, 20 - 59 nm	40	974192-000	FOSC450-6D5DB20ANN2T-U23
5 BAND Dual BWDM + Express + 2 Test Ports, 20 - 59 nm	40	633361-000	FOSC450-6D5XB20ANN2T-U23
10 BAND Single BWDM + Express + 2 Test Ports, 20 - 59 nm	40	835167-000	FOSC450-6DNDB20ANN2T-U23
10 BAND Dual BWDM + Express + 2 Test Ports, 20 - 59 nm	40	614295-000	FOSC450-6DNXB20ANN2T-U23

FOSC 450

Miscellaneous Accessories

Category	Kit Includes	Item	Description	Part Number
Workstand	Clamp for holding FOSC 450 closure during splicing	FOSC 450 Closure Workstand	FOSC-ACC-450-WORKSTAND	941802-000
Flame Retardant Coverings	1 flame retardant bag for FOSC 450 A, B or BS (B Short) closure	Flame Retardant Vault Bag for A & B Size Closures	FOSC-ACC-A/B-VAULT-BAG	263245-000
	1 flame retardant bag for FOSC 450 C or D closure	Flame Retardant Vault Bag for C & D Size Closures	FOSC-ACC-D-VAULT-BAG	766709-000
Closure Upgrade Kit	Kit to upgrade FOSC 450C closure 450D. Includes D size dome and 36 count splice tray (additional trays sold separately).	FOSC 450C to 450D Upgrade Kit	FOSC-ACC-C-D-CONVRSION	9J701X-000
Closure Rehab Kit	FOSC 450C and D version base separable into 2 halves. For rehabilitation of closures with wide splice trays into a FOSC 450 C or D closure.	FOSC 450 C&D Split Base	FOSC-450D-SPLTBASE-01	D80569-000
	Combination 450 D closure and Split Base	FOSC 450 D Rehab Kit	FOSC450-D6-REHAB-KIT	RH0070-000
Label Cards	Blue Label Cards with numbers F1-F24 & 1TO-8TO	Label Cards - Blue	FOSC-ACC-ID-LBLCARD-BLUE	119982-000
	White Label Cards with numbers D1-D24, 1-8	Label Cards - White	FOSC-ACC-ID-LBLCARD-WHT	759952-000
	Identification label for A&B trays	Label for A & B trays	FOSC-ACC-DECAL-ID-ABTRAY	E34360-000
Slack Storage Sock	Loose buffer tube storage sock for 450A, B and BS closures.	Loose Buffer Tube Storage Sock for A, BS, B Closures	FOSC-ACC-LBT-SOCK	769441-000
	Loose buffer tube storage sock for 450 C & D closures.	Loose Buffer Tube Storage Sock for C & D Closures	FOSC400-D-SOCK	019008-000
Wraps	Multi-functional adhesive backed wrap primarily for placement onto loose buffer tubes as they enter a splice tray.	Loose Buffer Tube Wrap	FOSC-ACC-LBT-WRAP-100	RH0073-000
	Multi-functional adhesive backed wrap primarily for placement onto drop cables to be placed under the cable retention clamp hardware.	Multi-Drop Wrap	FOSC-ACC-MD-WRAP-25	RH0126-000
Shield Continuity		Shield Continuity Clamp	FOSC-ACC-SHIELDCONTCLMP	9V219F-000
Splice Tray Accessories	Specially designed holder for attaching un-tubed ribbons onto a splice tray	Ribbon Fiber Termination Module	FOSC-ACC-RIBBON-TERM-MOD	D7512P-000
	Device for separating ribbons routing to different splice trays	D Basket Ribbon Router	FOSC-ACC-D-RIBBON-ROUTER	525147-000
	Tray tabs for A & B splice trays	FOSC Tray Hold-down Tabs	FOSC-ACC-TRAY-HOLD-TABS	D77919-000
	Tie-wraps for splice trays	FOSC Tray Tie-wraps	FOSC-ACC-TRAY-TY-RAPS	L5904R-000
Tray Backbone	Bracket for holding trays in position when no slack basket is present	Tray Backbone	FOSC-ACC-D-BACKBONE	F47112-00a
Straps to Secure Trays	Strap for securing trays in FOSC 450 A, BS closures	FOSC Tray Velcro Strap - Black	FOSC-ACC-VELCROSTRAP-16	L48638-000
	Strap for securing trays in FOSC 450 B, C and D closures	FOSC Tray Velcro Strap - Red	FOSC-ACC-VELCROSTRAP-25	66994Z-000
Strength Member Bracket	Large size strength member bracket	Large Strength Member Bracket	FOSC-ACC-STRMEM-BRKT-LG	135731-000
Specialty Tools	Raucut1 tooling to open cut or uncut (midspan) buffer tubes. Kit includes inserts for tubes 1.8 mm to 4.2mm diameter	Buffer Tube Stripper Tool	FACC-AXIAL-STRIPPER-RC1	250960-000

FOSC 450

Additional FOSC Fiber Optic Splice Closures

A family of closures designed for your fiber network needs!

FOSC 450 fiber optic splice closures is just one of several families of FOSC closures that connect, protect and seal the fiber optic network.

The information that follows describes some of the other closure families and products available for your fiber network from TE.



FOSC 250 CLOSURE

The FOSC 250 splice closure sets a new standard in installation efficiency for Fiber-to-the-Home applications. Specifically designed for more efficient termination of drop or terminal cables to the distribution cable, the FOSC 250 splice closure utilizes an integrated splice tray, slack basket, and compressed gel sealed base that simplifies training and installation while reducing loose or unused closure parts, deployment times, installation errors, and overall installation costs.



FOSC 400 CLOSURES

Similar to the 450 family, this is a family of single ended (butt) style fiber optic splice closures utilizing heat shrink cable sealing rather than gel. Other features include a removable dome, hinging splice trays and a range of sizes and styles to choose from.



FOSC 400 FLAME RETARDANT CLOSURES

Flame retardant versions of the FOSC 400 B and 400 D closures.



FOSC 500 CLOSURES

The smallest of the FOSC closure family, the 500 uses gel sealing and can be configured for butt or inline splicing. Slack storage is limited to bare fibers, and has a twenty-four single splice capacity.



FOSC 600 CLOSURES

The largest of the FOSC closure family, 600 fiber optic splice closures are a great fit for applications such as large cable splicing in the network backbone, consolidating a large number of cables and splices, or rehabilitating failed closures.



FOSC 350 CLOSURE

The new FOSC 350 in-line gel sealed fiber splice closure holds up to 96 single splices (196 for 12-fiber ribbons). This two-halved, re-enterable and re-useable closure incorporates four cable entry ports, hinging splice trays, and toolless perimeter latches. Accessory kits are available for bringing multiple cables through a single cable port.



AIR FOSC CLOSURES

These free breathing closures are designed for aerial applications and provide either taut sheath or inline (with slack) splicing. The rodent resistant body and FOSC splice trays provide an efficient closure to connect, protect and distribute fiber and fiber cables.



GATOR 12F GEL SPLICE CLOSURE

TE introduces a small splice closure designed for splicing two flat drop style cables.

- Small enough to fit into "flower pot" size hand holes
- Accommodates up to 12 single fibers, 12 ribbonized fibers, or one 12 fiber ribbon

For additional information, contact your local area sales representative or visit our web site:
www.te.com/TelecomNetworks

In the following section you will find dimensional and assembly information and drawings related to FOSC 450 fiber optic splice closures and accessories. Additional information is available upon request.

**FOSC 450 Closure Family
Assembly Drawings**

450 A – Shown with 2 standard splice trays and tall version slack basket

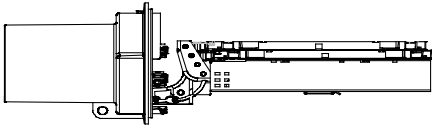

450 B – Shown with 6 standard splice trays and standard version slack basket

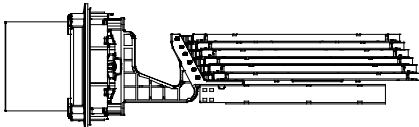

450 BS (B Short) – Shown with 6 standard splice trays and standard version slack basket

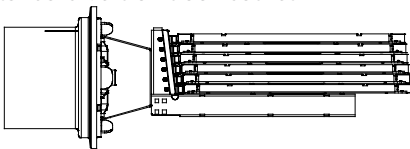

450 C/D – D size shown with 6 standard splice trays and standard version slack basket. Note: FOSC 450 C closure is not shown, but will replicate the D size with the exception of shorter trays, basket, and dome.

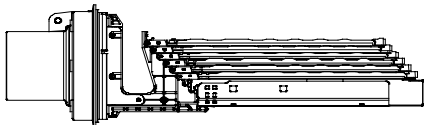

Note: The drawings are not to scale



Closure Dimensions

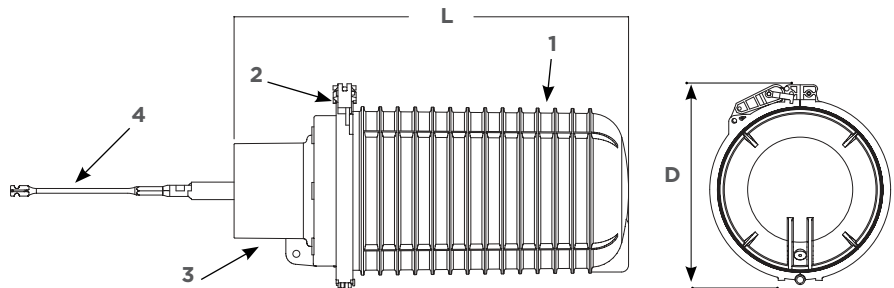

Gel-Block Profiles

Drawing Key

- 1. Dome
- 2. Clamp
- 3. Base
- 4. Trigger

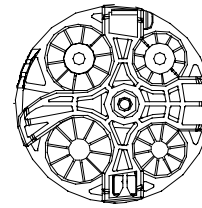

450 A

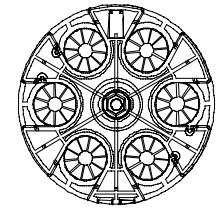

**450 BS, B6,
C6, D6**

Closure Size (Dimensions in inches)

	A	BS	B6	C6	D6
L Total closure length, excluding trigger	19	19	24	23	30
D Closure outer diameter, including clamp	8	9.2	9.8	11.5	11.5

NOTE: Diameters excluding clamp are approximately 2 inches less.

Cable port dimensions (Dimensions in inches)

	A	BS	B6	C6	D6
Number round cable ports	4	6	6	6	6
Cable diameter range	.30 -.87 (2X)	.35-1	.35-1	.35-1	.35-1
	.39 -1.10 (2X)				

SPLICE TRAY DIMENSIONS

Tray Sizes	Fits FOSC Closure Size					Tray Fiber Capacity Versions Available		Nominal Tray Dimensions (inches, hinge not included)
	400	450	500	600	AIR FOSC	Single	Mass	L x W x H
A	A4, A8	A4, BS	N/A	N/A	A	12, 24	72*	9 1/8 x 3 7/8 x 7/16
B	B2, B4	B6	N/A	N/A	B	12, 24	72*	12 x 3 7/8 x 7/16
C	C5	C6	N/A	N/A	N/A	12, 24	144*	7 1/2 x 5 7/8 x 7/16
D	D5	D6	N/A	C or D	N/A	36, 72, 96	288*	15 x 5 7/8 x 7/16
A/B Ribbon	A4, A8, B2, B4	A4, BS, B6	N/A	N/A	A & B	N/A	144	9 1/8 x 3 7/8 x 1
C Ribbon	C5	C6	N/A	N/A	N/A	N/A	216	7 1/2 x 5 7/8 x 1
D Ribbon	D5	D6	N/A	C or D	N/A	N/A	288	15 x 5 7/8 x 1

*When performing mass fusion splicing on these trays, ribbon slack must be stored on a separate tray or slack basket.

FOSC Fiber Optic Splice Closures

Quick Reference Guide

Closure	HEAT-SHRINK CABLE SEALING										GEL CABLE SEALING						BREATHABLE	
	FOSC 400					FOSC 450					FOSC 500			FOSC 600			AIR FOSC	
	D5	C5	B2	B4	A4	A8	D6	C6	B6	BS	A4	AA	D	C	A	B		
Type/Size	11.5 dia. 31L 16	11.5 dia. 23L 12	8 dia. 25L 8"	8 dia. 25L 8"	8 dia. 19.5L 6"	11.5 dia. 30L 20	11.5 dia. 23L 16	9.8 dia. 24L 13	9.2 dia. 19L 10	8 dia. 19L 6	19 Lx2.5x5 5	33 Lx10x11 31	33 Lx6x11 30"	29.5/37 Lx6x5 22/15				
Closure Size¹ (inches) Approx. Closure Weights (lbs)	288	96	48	48	24	24	288	72	72	48	24 ²	324	180	48				
Closure Capacity End-to-End	288	96	48	48	24	24	288	72	72	48	24 ²	324	180	48				
Single Splice (SM6 Modules)	288	96	48	48	24	24	288	72	72	48	24 ²	324	180	48				
Single Splice (SM12 Modules) ¹²	576	192	96	96	48	48	576	144	144	96	24 ²	648/864 ²	360/480 ²	96				
Mass Fusion Splice	1152	864	144	144	n/a	144	1152	288	144	144	n/a	1728	864	288				
Mid-Sheath																		
Single Splice	432	192	96	96	48	48	576	144	144	72	24	864	480	96				
Mass Fusion Splice	864	432	144	144	n/a	144	864	288	288	216	n/a	1728	864	288				
Trays Per Closure																		
Standard Trays	8 ⁴ /6 ⁵ /5 ⁶	8 ⁴ /6 ⁵ /5 ⁶	4 ⁴	4 ⁴	2 ⁵	4 ⁴ /3 ⁵ /2 ⁶	8 ⁴ /6 ⁵ /5 ⁶	6 ⁴ /6 ⁵ /4 ⁶	6 ⁴ /6 ⁵ /2 ⁶	4 ⁴ /3 ⁵ /6 ⁶	1	9	5	4				
Standard Trays/Ribbon Trays	4 ⁴ /3 ⁵ /2 ⁶	4 ⁴ /3 ⁵ /2 ⁶	2 ⁶	2 ⁶	1 ⁷	2 ⁷ /1 ⁸ /1 ⁹	4 ⁴ /3 ⁵ /2 ⁶	3 ⁴ /3 ⁵ /2 ⁶	3 ⁴ /3 ⁵ /1 ⁶	2 ⁷ /2 ⁷ /1 ⁸	n/a	5 ³	3 ¹	n/a ¹¹				
Single Fiber Splice Capacity per Tray																		
SM6 Modules	36	12	12	12	12	12	36	12	12	12	n/a	36	36	12				
SM12 Modules ¹²	72	24	24	24	24	24	72	24	24	24	n/a	72	72	24				
FIST Modules ¹²	96	n/a	n/a	n/a	n/a	n/a	96	n/a	n/a	n/a	24	96	96	n/a				
Patching																		
Tray (quantity/type)	Yes (12/16/sc)	No	No	No	No/No	No/No	Yes (12/16/sc)	Yes (12/16/sc)	No	No	No	Yes (12/16/sc)	Yes (12/16/sc)	No	Yes (12/16/sc)	No		
Basket (quantity/type)	Yes (4/all, 8/sc)	No	Yes (4/all, 8/sc)	Yes (4/all, 8/sc)	Yes (4/all, 8/sc)	Yes (4/all, 8/sc)	Yes (4/all, 8/sc)	Yes (4/all, 8/sc)	Yes (4/all, 8/sc)	Yes (4/all, 8/sc)	No	No	No	No	No	No		
Sealing System																		
Closure Dome-to-Base or Top-to-Bottom	"O" Ring/ Clamp	"O" Ring/ Clamp	"O" Ring/ Clamp	"O" Ring/ Clamp	"O" Ring/ Clamp	"O" Ring/ Clamp	"O" Ring/ Clamp	"O" Ring/ Clamp	"O" Ring/ Clamp	"O" Ring/ Clamp	Dry Gasket	Dry Gasket	Dry Gasket	Breathable				
Cable Capacity																		
Butt (std./max.)	7/12 ⁹	7/12 ⁹	4/8 ⁹	6/10 ⁹	6 ⁹	10 ⁹	6/16/21 ⁸	6/16/21 ⁸	6/16/21 ⁸	4/10/13 ⁸	2	8/16/20 ⁸	8/16/20 ⁸	n/a up to 12				
Inline (std./max.)	n/a	n/a	n/a	n/a	n/a	n/a	n/a	n/a	n/a	n/a	4	12/20/24 ⁸	12/20/24 ⁸	n/a up to 12				
Fire Retardant Closure Available	Yes (400-D5/FR)	No ¹⁰	Yes (400-D5/FR)	Yes (400-D5/FR)	No ¹⁰	No ¹⁰	No ¹⁰	No ¹⁰	No ¹⁰	No ¹⁰	No	No	No	No	No	No		
Tools Required	CV-1981 Hot Air Gun, Power	CV-1981 Hot Air Gun, Power	CV-1981 Hot Air Gun, Power	CV-1981 Hot Air Gun, Power	CV-1981 Hot Air Gun, Power	CV-1981 Hot Air Gun, Power	Can Wrench, Snips	Can Wrench, Snips	Can Wrench, Snips	Can Wrench, Snips	1/2" Nut Driver, Screwdriver	1/2" Nut Driver, Screwdriver	1/2" Nut Driver, Screwdriver	1/2" Nut Driver	1/2" Nut Driver			

¹ Using C-36 trays (mechanical modules)
² Closure length ("L") plus TOX largest cable diameter installed equals the overall length required for handle. Maximum dimensions include clamp and cable sealing. Diameter dimensions include clamp. Diameters without clamps are approximately 2 inches less.
³ Trays configured with FIST style splice modules provide 96 single splice capacity - FOSC 400 D5 and 450 D6 closures can also accommodate FIST style modules (SMOUV splice protection sleeves must be used)
⁴ The ribbon tray can also be configured with 12 SC adapters for patching and provide 12 single splice capacity.
⁵ Flexible sock is used for LBT storage.
⁶ With standard basket.
⁷ If using the 3-cable multi-cable kit, 3 flat or 3 round cables per port if cable does not exceed <0.25" diameter
⁸ If using the 4-cable multi-cable kits and combined cables do not exceed 1" diameter.
⁹ Multiple cables per port can be installed (using SCOP or branch-off clip) if cable diameters do not exceed port diameter.
¹⁰ Fire Retardant bag or blanket options.
¹¹ Ribbon/mass fusion can be done but slack is pulled back into the slack area under the trays.
¹² SMOUV splice protection sleeves must be used.
¹³ FOSC 600 C closure uses "D" size splice trays

FOSC 400 Closure

FOSC 400 - XX - XX - X - XXX

Closure size (inches) _____

Cable entry ports (in addition to oval port which is included with each kit) _____

Capacity (or type) of splice tray _____

Valve for flash test _____

Ground feed-through lugs _____

Cable blocking components _____

Number of splice trays _____

FOSC 450 Closure

FOSC 450 - XX - X - XX - X - XXX

Closure size (inches) _____

Number of cable ports for which termination hardware is provided _____

Capacity (or type) of splice tray _____

Number of trays pre-installed _____

Valve for flash test _____

Ground feed-through lugs _____

Slack Basket type _____

FOSC 500 Closure

FOSC-500AA-XXX-XX-X-X

Splicing tray _____

Cable type _____

Ground feed-through lugs _____

Valve for flash test _____

FOSC 600 Closure

FOSC 600 - X X X - XX - X - X X X

Closure size _____

Number of cable ports provided _____

Configuration _____

Capacity (or type) of splice trays _____

Valve for flash-test _____

Ground feed-through lugs _____

Slack Basket type _____

Number of splice trays _____

AIR FOSC Closure

AIR-FOSC - X - XXX - XX - X X X

Closure size _____

Style _____

Tray style _____

Number of trays _____

Grounding _____

Miscellaneous _____

Closure Splice Tray Guide

Tray Size	Tray Fiber Capacity Single	Mass	Nominal Tray Dimensions (L x W x H)	Fits the following closure sizes:				
				FOSC 400	FOSC 450	FOSC 500	FOSC 600	AIR FOSC
FOSC A	12, 24	72	9 1/8 x 3 7/8 x 7/16	A4, A8	N/A	N/A	N/A	AIR FOSC A
FOSC B	12, 24	72	12 x 3 7/8 x 7/16	B2, B4	B6	N/A	N/A	AIR FOSC B
FOSC C	12, 24	144	7 1/2 x 5 7/8 x 7/16	C5	C6	N/A	N/A	N/A
FOSC D	36, 72, 96	288	15 x 5 7/8 x 7/16	D5	D6	N/A	N/A	Cor D N/A
FOSC A/B Ribbon	N/A	144	9 1/8 x 3 7/8 x 1	A4, A8, B2, B4	A4, BS, B6	N/A	N/A	AIR FOSC A, AIR FOSC B
FOSC C Ribbon	N/A	216	7 1/2 x 5 7/8 x 1	C5	C6	N/A	N/A	N/A
FOSC D Ribbon	N/A	288	15 x 5 7/8 x 1	D5	D6	N/A	N/A	Cor D N/A

*inches; hinge not included

CLASS A FOSC Closures

FOSC 400

FOSC400-A4-NT-0-NGV C22578-000

FOSC400-A8-NT-0-NGV F84540-000

FOSC400-B2-NT-0-NGV 755467-000

FOSC400-B4-NT-0-NGV 677893-000

FOSC400-C5-NT-0-NGV L21886-000

FOSC400-D5-NT-0-NGV 430987-000

FOSC 600

FOSC600-C8B-NT-0-C4V 531296-000

FOSC600-C8-NT-0-C4V A13992-000

FOSC600-D8B-NT-0-D4V 867502-000

FOSC600-D8-NT-0-D4V F90616-000

*NT indicates that no tray is factory installed in this closure.

FOSC 450

FOSC450-A4-4-NT-0-A1V A08617-000

FOSC450-A4-4-NT-0-N0V A47106-000

FOSC450-A4-4-NT-0-N1V A89777-000

FOSC450-B5-6-NT-0-B0V F34112-000

FOSC450-B5-4-NT-0-N0V V98542-000

FOSC450-B6-6-NT-0-B3V 058514-000

FOSC450-B6-4-NT-0-N0V EK9632-000

FOSC450-B6-4-NT-0-N3V 47214Z-000

FOSC450-C6-6-NT-0-C6V J1945R-000

FOSC450-C6-4-NT-0-N0V KR7894-000

FOSC450-C6-4-NT-0-N3V DM6321-000

FOSC450-D6-6-NT-0-D6V 931866-000

FOSC450-D6-4-NT-0-N0V C06369-000

FOSC450-D6-4-NT-0-N3V E43425-000

CLASS B FOSC Closures

(Contact TE's Customer Service for complete list.)

Includes all CLASS A configurations with 12, 24, and Ribbon trays (FOSC400, 450 A, B and C closures) or 36, 72 and Ribbon Trays (FOSC400, 450 D closures, FOSC600 Closures). Some sizes available with tall slack storage baskets.

ex: FOSC400-D5-36-1-NGV 197697-000

ex: FOSC450-C6-4-12-1-C6V Y53157-000

ex: FOSC600-D8B-R2-1-D4V A37830-000

Includes non-grounded CLASS A configurations with 12, 24, and Ribbon trays (FOSC400, 450 A, B and C closures) or 36, 72 and Ribbon Trays (FOSC400, 450 D closures, FOSC600 Closures). Some sizes available with tall slack storage baskets.

ex: FOSC400-B4-12-1-BNV 886337-000

ex: FOSC450-B6-4-24-1-B0V 776482-000

ex: FOSC600-C8B-36-1-C0V 7X2580-000

Includes RUS closure configurations.

<p>A</p> <p>Accessories</p> <p>Cable Termination:..... 11</p> <p>Closure Mounting Hardware:..... 16</p> <p>Pedestal: 16</p> <p>Pole: 16</p> <p>Wall: 16</p> <p>Closure Mounting Hardware Aerial: 16</p> <p>Closure Sealing: 12</p> <p>Fiber Management: 15</p> <p>Fiber Routing: 15</p> <p>Miscellaneous: 28</p> <p>Patch Trays: 14</p> <p>Ribbon Fiber Trays: 14</p> <p>Splice Modules: 14</p> <p>Splice Tray: 13</p> <p>Splice Tray Covers: 14</p> <p>AIR FOSC Closures: 29</p> <p>B</p> <p>Base: 7</p> <p>C</p> <p>Class A List: 9</p> <p>Class B List: 9</p> <p>Class C List: 9</p> <p>Closure</p> <p>Dimensions: 34</p> <p>FOSC 250:..... 33</p> <p>FOSC 400:..... 33</p> <p>Kit Contents: 7</p> <p>Closure Dimensions:..... 34</p> <p>Closure Mounting:..... 16</p> <p>Closure Mounting Hardware Accessories:..... 16</p> <p>Closures</p> <p>AIR FOSC: 33</p> <p>FOSC 350:..... 33</p> <p>FOSC 400</p> <p>Flame Retardant:..... 33</p> <p>FOSC 500: 33</p> <p>CWDM: 20, 22</p>	<p>D</p> <p>Dimensions</p> <p>Closure: 34</p> <p>Splice Tray:..... 35</p> <p>Dome: 7</p> <p>Dome to Base Seal: 7</p> <p>Drawings</p> <p>FOSC 450 A:..... 34</p> <p>FOSC 450 B: 34</p> <p>FOSC 450 BS (B Short):..... 34</p> <p>FOSC 450 C: 34</p> <p>FOSC 450 D: 34</p> <p>F</p> <p>Field-Installable CWDM:..... 22</p> <p>Field-Installable Splitter: 18</p> <p>FOSC 250 Closure: 33</p> <p>FOSC 350 Closure: 33</p> <p>FOSC 400 Closures:..... 33</p> <p>FOSC 400 Flame Retardant Closures:... 33</p> <p>FOSC 500 Closures:..... 33</p> <p>FOSC Closures</p> <p>450 A:..... 5</p> <p>450 B: 5</p> <p>450 B Short:..... 5</p> <p>450 C: 5</p> <p>450 D:..... 5</p> <p>FOSC OC CWDM:..... 20</p> <p>FOSC OC Splitter: 17</p> <p>G</p> <p>Gel Block: 7</p> <p>M</p> <p>Mounting: 16</p> <p>P</p> <p>Passives</p> <p>CWDMs: 23, 24</p> <p>Splitters:..... 19</p> <p>Patch Trays: 14</p>	<p>R</p> <p>Ribbon Fiber Trays: 14</p> <p>S</p> <p>Seal: 7</p> <p>SMOUV Fusion Splice Protection Sleeve:... 14</p> <p>Splice Modules: 14</p> <p>Splice Tray Covers:..... 14</p> <p>Splice Tray Dimensions: 31</p> <p>Splitter:..... 17, 18</p> <p>T</p> <p>Trigger:..... 7</p>
--	--	---

FOSC 450

Gel-Sealed Fiber Optic Splice Closure

te.com

TE Connectivity, TE Connectivity (logo) and Every Connection Counts are trademarks. All other logos, products and/or company names referred to herein might be trademarks of their respective owners.

The information given herein, including drawings, illustrations and schematics which are intended for illustration purposes only, is believed to be reliable. However, TE Connectivity makes no warranties as to its accuracy or completeness and disclaims any liability in connection with its use. TE Connectivity's obligations shall only be as set forth in TE Connectivity's Standard Terms and Conditions of Sale for this product and in no case will TE Connectivity be liable for any incidental, indirect or consequential damages arising out of the sale, resale, use or misuse of the product. Users of TE Connectivity products should make their own evaluation to determine the suitability of each such product for the specific application.

© 2015 TE Connectivity Ltd. family of companies All Rights Reserved.

316384.1AE 03/15 Revision

CATALOG

Contact us

P.O. Box 1101
Minneapolis, Minnesota
USA 55440-1101

Tel: 1-800-366-3891 x73000
1-952-917-3000

Fax: 1-952-917-3237

www.te.com/TelecomNetworks