

REVISIONS			
REV	DESCRIPTION, ECN, EAR NO.	DATE	APPD
A	PROPOSAL DRAWING	NOV30/18	S.M.
B	CURRENT RATING CHANGE	JAN22/19	S.M.

WIRE SIZE	MAX INSULATION	DIM 'A'	DIM 'B'	DIM 'C'	DIM 'D'	DIM 'E'	DIM 'F'
18 - 22	1.5	2.29	2.54	0.76	1.91	2.08	0.64

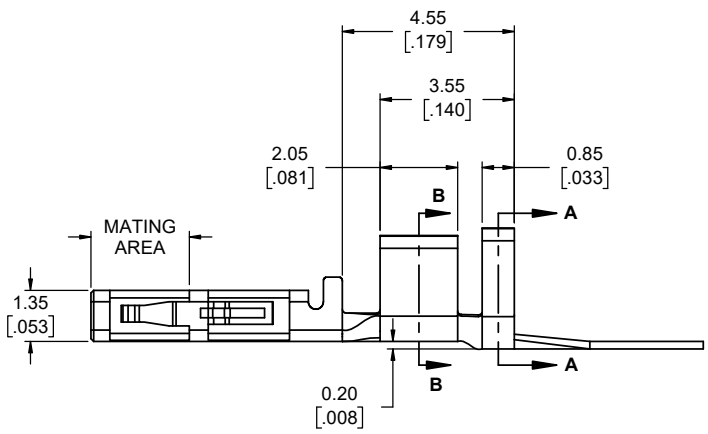
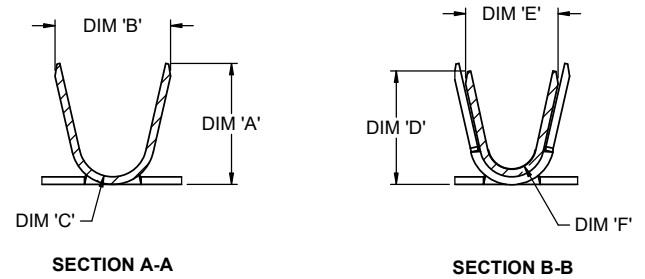
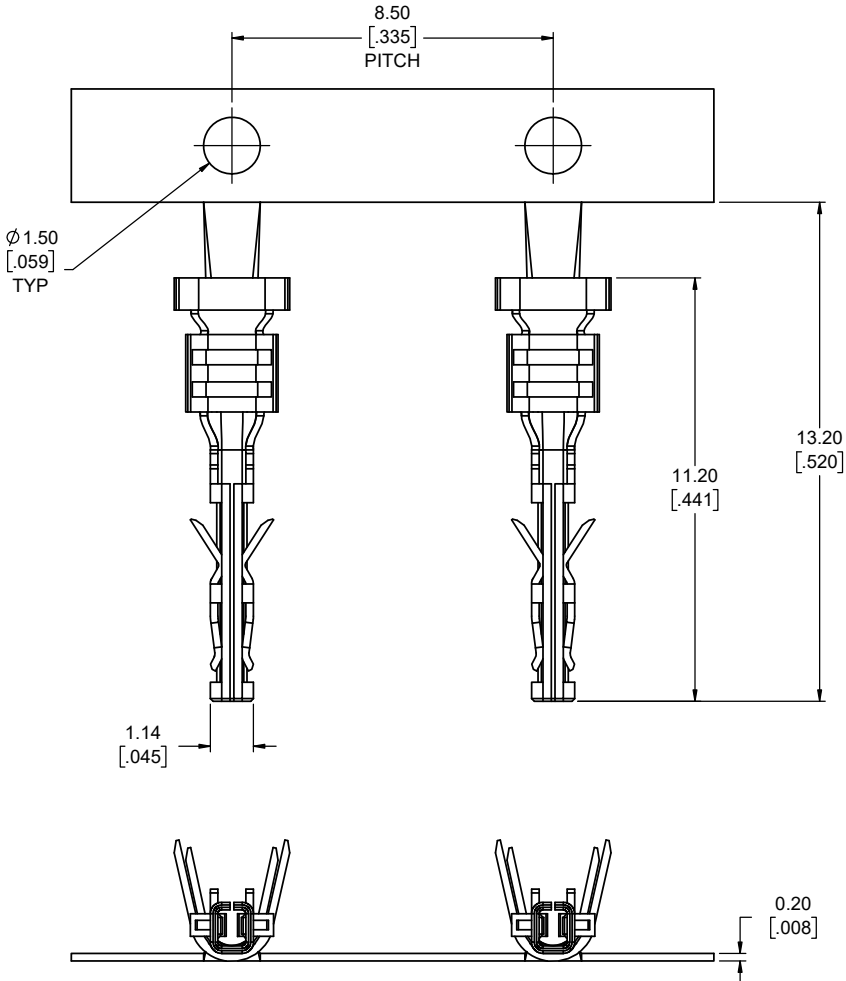

PART NUMBER: FLH - SC136 - XXX

SERIES
FLH

CONTACT TYPE
SC = SOCKET CONTACT
3 = AWG #18 - AWG #22

CONTACT FINISH
T01 = 100µ" TIN
G15 = 15µ" GOLD
G30 = 30µ" GOLD

NOTES:

- MATERIALS: ALL MATERIALS ARE RoHS COMPLIANT PER EU DIRECTIVE 2011/65/EU & AMENDMENTS
 - CONTACTS: PHOSPHOR BRONZE PLATED WITH NICKEL UNDER PLATE ALL OVER. MATING AREA PLATED WITH MATTE TIN OR GOLD AS DEFINED BY THE PART NUMBER SELECTED.
- ELECTRICAL CHARACTERISTICS
 - CURRENT RATING: 8A (18 AWG) OR 5A (20 AWG) OR 3A (22 AWG) PER CONTACT WHEN USING 3 CONTACTS
 - OPERATING TEMPERATURE: -40°C TO +105°C
- CONTACT DESIGNED FOR SOCKET HOUSING P/N: FLH-SX1-00



AMPHENOL PART NUMBER: FLH-SC136-XXX

UNLESS SPECIFIED OTHERWISE	DRAWN	B.COPPING	NOV30/18
PRIMARY UNITS MILLIMETERS	CHECKED	S.MUGAN	NOV30/18
SECONDARY INCHES	M.E. APPD		
REFERENCE IN PARENTHESES	Q.A. APPD		
GENERAL TOLERANCES	DWG APPR.		
1 DECIMAL PLACE	ENG. REL. NO.		
2 DECIMAL PLACES ±0.20	REF.		
3 DECIMAL PLACES	THIRD ANGLE PROJECTION		
ANGULAR DEGREES	DO NOT SCALE DRAWING		

Amphenol Canada Corp.
Commercial Products

FLH SERIES, 2.5mm PITCH
SOCKET CONTACT, CRIMP
TERMINATION, RoHS COMPLIANT

DWG. NO. **P-FLH-SC136-XXX** REV **B**

CODE ID NO. 03554 DWG SIZE: X SCALE: 10:1 SHEET 1 OF 2

REVISIONS			
REV	DESCRIPTION, ECN, EAR NO.	DATE	APPD
A	PROPOSAL DRAWING	NOV30/18	S.M.
B	CURRENT RATING CHANGE	JAN22/19	S.M.

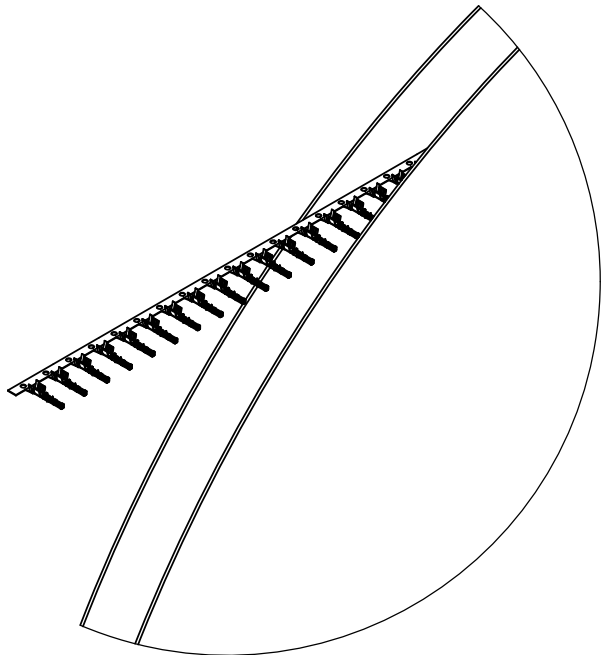

DETAIL C
SCALE 1 : 1

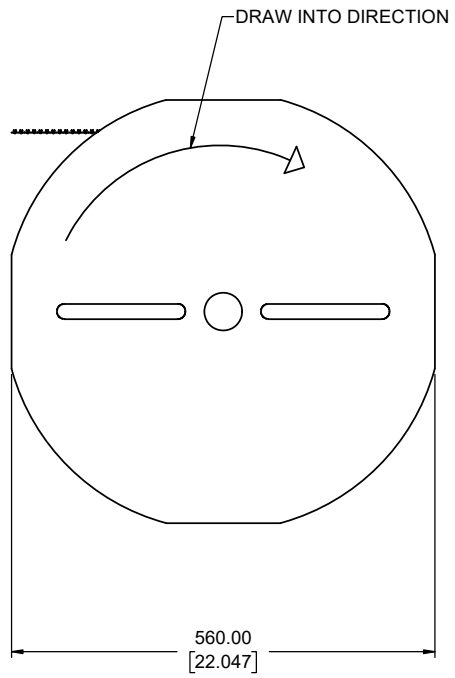
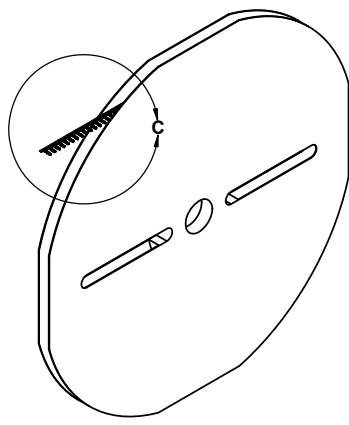

UNLESS SPECIFIED OTHERWISE	DRAWN	B.COPPING	NOV30/18
PRIMARY UNITS MILLIMETERS	CHECKED	S.MUGAN	NOV30/18
SECONDARY INCHES	M.E. APPD		
REFERENCE IN PARENTHESES	Q.A. APPD		
GENERAL TOLERANCES	DWG APPR.		
1 DECIMAL PLACE	ENG. REL. NO.		
2 DECIMAL PLACES ±0.20	REF.		
3 DECIMAL PLACES	THIRD ANGLE PROJECTION		DO NOT SCALE DRAWING
ANGULAR DEGREES			

Amphenol Canada Corp.
Commercial Products

FLH SERIES, 2.5mm PITCH
SOCKET CONTACT, CRIMP
TERMINATION, RoHS COMPLIANT

DWG. NO. **P-FLH-SC136-XXX** REV **B**

CODE ID NO. 03554 DWG SIZE: X SCALE: 1:5 SHEET 2 OF 2

THIS DOCUMENT CONTAINS PROPRIETARY INFORMATION AND SUCH INFORMATION MAY NOT BE DISCLOSED TO OTHERS FOR ANY PURPOSE OR USED FOR MANUFACTURING PURPOSES WITHOUT WRITTEN PERMISSION FROM AMPHENOL CANADA CORP.