



Is Now Part of



**ON Semiconductor®**

To learn more about ON Semiconductor, please visit our website at  
[www.onsemi.com](http://www.onsemi.com)

Please note: As part of the Fairchild Semiconductor integration, some of the Fairchild orderable part numbers will need to change in order to meet ON Semiconductor's system requirements. Since the ON Semiconductor product management systems do not have the ability to manage part nomenclature that utilizes an underscore (\_), the underscore (\_) in the Fairchild part numbers will be changed to a dash (-). This document may contain device numbers with an underscore (\_). Please check the ON Semiconductor website to verify the updated device numbers. The most current and up-to-date ordering information can be found at [www.onsemi.com](http://www.onsemi.com). Please email any questions regarding the system integration to [Fairchild\\_questions@onsemi.com](mailto:Fairchild_questions@onsemi.com).

ON Semiconductor and the ON Semiconductor logo are trademarks of Semiconductor Components Industries, LLC dba ON Semiconductor or its subsidiaries in the United States and/or other countries. ON Semiconductor owns the rights to a number of patents, trademarks, copyrights, trade secrets, and other intellectual property. A listing of ON Semiconductor's product/patent coverage may be accessed at [www.onsemi.com/site/pdf/Patent-Marking.pdf](http://www.onsemi.com/site/pdf/Patent-Marking.pdf). ON Semiconductor reserves the right to make changes without further notice to any products herein. ON Semiconductor makes no warranty, representation or guarantee regarding the suitability of its products for any particular purpose, nor does ON Semiconductor assume any liability arising out of the application or use of any product or circuit, and specifically disclaims any and all liability, including without limitation special, consequential or incidental damages. Buyer is responsible for its products and applications using ON Semiconductor products, including compliance with all laws, regulations and safety requirements or standards, regardless of any support or applications information provided by ON Semiconductor. "Typical" parameters which may be provided in ON Semiconductor data sheets and/or specifications can and do vary in different applications and actual performance may vary over time. All operating parameters, including "Typicals" must be validated for each customer application by customer's technical experts. ON Semiconductor does not convey any license under its patent rights nor the rights of others. ON Semiconductor products are not designed, intended, or authorized for use as a critical component in life support systems or any FDA Class 3 medical devices or medical devices with a same or similar classification in a foreign jurisdiction or any devices intended for implantation in the human body. Should Buyer purchase or use ON Semiconductor products for any such unintended or unauthorized application, Buyer shall indemnify and hold ON Semiconductor and its officers, employees, subsidiaries, affiliates, and distributors harmless against all claims, costs, damages, and expenses, and reasonable attorney fees arising out of, directly or indirectly, any claim of personal injury or death associated with such unintended or unauthorized use, even if such claim alleges that ON Semiconductor was negligent regarding the design or manufacture of the part. ON Semiconductor is an Equal Opportunity/Affirmative Action Employer. This literature is subject to all applicable copyright laws and is not for resale in any manner.



# FL7730

## Single-Stage Primary-Side-Regulation PWM Controller for PFC and LED Dimmable Driving

### Features

- Compatible with Traditional TRIAC Control (No need to change existing lamp infrastructure: wall switch & wire)
- Compatible with Non-Dimming Lamp Designs
- Cost-Effective Solution without Input Bulk Capacitor and Feedback Circuitry
- Power Factor Correction (PFC)
- Accurate Constant-Current (CC) Control, Independent Online Voltage, Output Voltage, Magnetizing Inductance Variation
- Line Voltage Compensation for CC Control
- Linear Frequency Control for Better Efficiency and Simple Design
- Open-LED Protection
- Short-LED Protection
- Cycle-by-Cycle Current Limiting
- Over-Temperature Protection with Auto Restart
- Low Startup Current: 20  $\mu$ A
- Low Operating Current: 5 mA
- SOP-8 Package Available
- Application Voltage Range: 80 V<sub>AC</sub> ~ 308 V<sub>AC</sub>

### Applications

- LED Lighting System

### Description

This highly integrated PWM controller, FL7730, provides several features to enhance the performance of single-stage flyback converters. The proprietary topology, TRUECURRENT<sup>®</sup> enables the simplified circuit design for LED lighting applications.

TRIAC dimming is smoothly managed by dimming brightness control without flicker. By using single-stage topology with primary-side regulation, an LED lighting board can be implemented with few external components and minimized cost. It does not require an input bulk capacitor or feedback circuitry. To implement good power factor and low total harmonic distortion, constant on-time control is utilized with an external capacitor connected to the COM1 pin.

Precise constant-current control regulates accurate output current versus changes in input voltage and output voltage. The operating frequency is proportionally changed by the output voltage to guarantee Discontinuous Conduction Mode (DCM) operation with higher efficiency and simpler design. The FL7730 provides protections such as open-LED, short-LED, and over-temperature protections. Current-limit level is automatically reduced to minimize output current and protect external components in a short-LED condition.

The FL7730 controller is available in an 8-pin Small Outline Package (SOP).

### Related Resources

[Evaluation Board: FEBFL7730\\_L20L008A](#)

[Evaluation Board: FEBFL7730\\_L20H008A](#)

### Ordering Information

Part Number	Operating Temperature Range	Package	Packing Method
FL7730MY_F116	-40°C to +125°C	8-Lead, Small Outline Package (SOP-8)	Tape & Reel

### Application Diagram

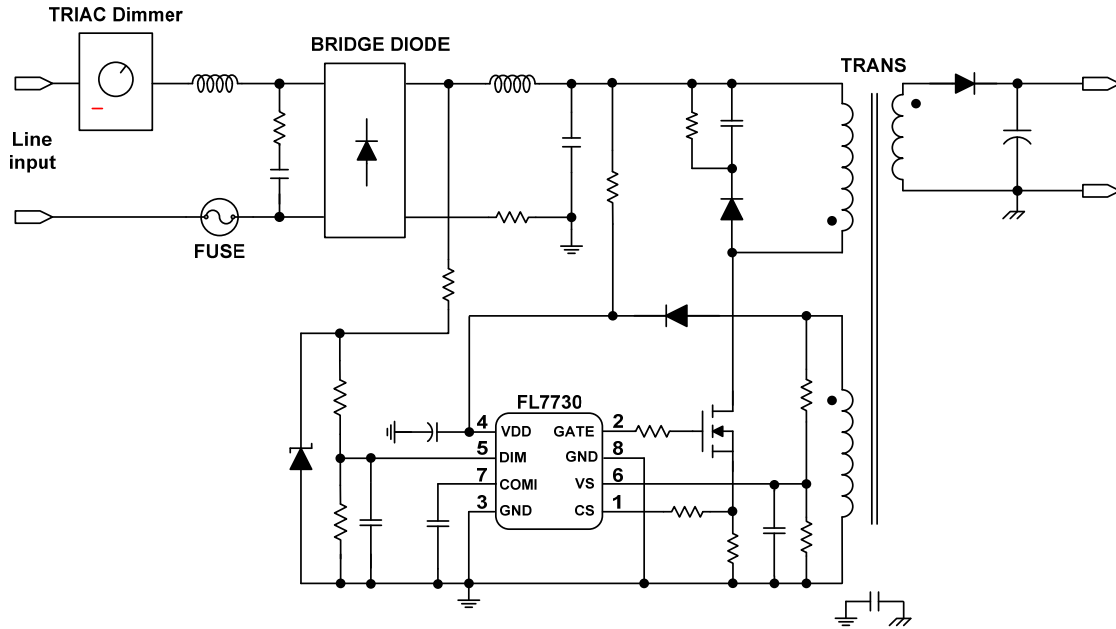

Figure 1. Typical Application

### Internal Block Diagram

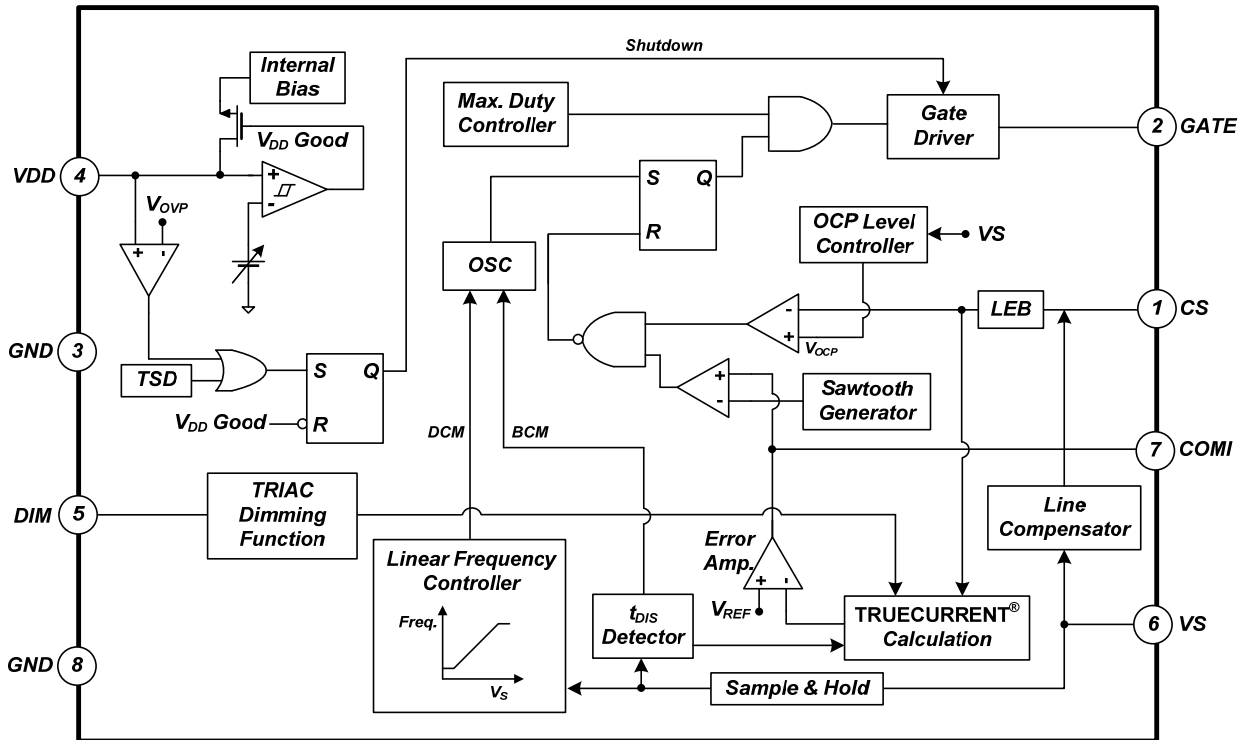
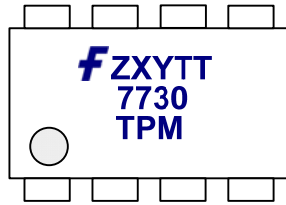

Figure 2. Functional Block Diagram

## Marking Information



F: Fairchild Logo  
 Z: Plant Code  
 X: 1-Digit Year Code  
 Y: 1-Digit Week Code  
 TT: 2-Digit Die Run Code  
 T: Package Type (M=SOP)  
 P: Z: Pb free, Y: Green package  
 M: Manufacture Flow Code

Figure 3. Top Mark

## Pin Configuration

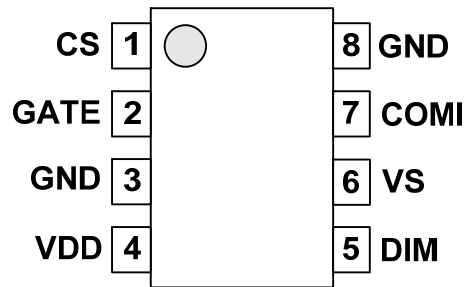

Figure 4. Pin Configuration

## Pin Definitions

Pin #	Name	Description
1	CS	<b>Current Sense.</b> This pin connects a current-sense resistor to detect the MOSFET current for the output-current regulation in constant current regulation.
2	GATE	<b>PWM Signal Output.</b> This pin uses the internal totem-pole output driver to drive the power MOSFET.
3	GND	<b>Ground</b>
4	VDD	<b>Power Supply.</b> IC operating current and MOSFET driving current are supplied using this pin.
5	DIM	<b>Dimming.</b> This pin controls the dimming operation of LED lighting.
6	VS	<b>Voltage Sense.</b> This pin detects the output voltage information and discharge time for linear frequency control and constant-current regulation. This pin connects divider resistors from the auxiliary winding.
7	COMI	<b>Constant Current Loop Compensation.</b> This pin is the output of the transconductance error amplifier.
8	GND	<b>Ground</b>

## Absolute Maximum Ratings

Stresses exceeding the absolute maximum ratings may damage the device. The device may not function or be operable above the recommended operating conditions and stressing the parts to these levels is not recommended. In addition, extended exposure to stresses above the recommended operating conditions may affect device reliability. The absolute maximum ratings are stress ratings only.

Symbol	Parameter	Min.	Max.	Unit
V <sub>VDD</sub>	DC Supply Voltage <sup>(1,22)</sup>		30	V
V <sub>VS</sub>	VS Pin Input Voltage	-0.3	7.0	V
V <sub>CS</sub>	CS Pin Input Voltage	-0.3	7.0	V
V <sub>DIM</sub>	DIM Pin Input Voltage	-0.3	7.0	V
V <sub>COMI</sub>	COMI Pin Input Voltage	-0.3	7.0	V
V <sub>GATE</sub>	GATE Pin Input Voltage	-0.3	30.0	V
P <sub>D</sub>	Power Dissipation (T <sub>A</sub> < 50°C)		633	mW
$\theta_{JA}$	Thermal Resistance (Junction to Air)		158	°C /W
$\theta_{JC}$	Thermal Resistance (Junction to Case)		39	°C /W
T <sub>J</sub>	Maximum Junction Temperature		150	°C
T <sub>STG</sub>	Storage Temperature Range	-55	150	°C
T <sub>L</sub>	Lead Temperature (Soldering, 10 Seconds)		260	°C

### Notes:

1. Stresses beyond those listed under Absolute Maximum Ratings may cause permanent damage to the device.
2. All voltage values, except differential voltages, are given with respect to the GND pin.

## Recommended Operating Conditions

The Recommended Operating Conditions table defines the conditions for actual device operation. Recommended operating conditions are specified to ensure optimal performance to the datasheet specifications. Fairchild does not recommend exceeding them or designing to Absolute Maximum Ratings.

Symbol	Parameter	Min.	Max.	Unit
T <sub>A</sub>	Operating Ambient Temperature	-40	125	°C

## Electrical Characteristics

$V_{DD}=20\text{ V}$  and  $T_A=25^\circ\text{C}$  unless otherwise specified.

Symbol	Parameter	Condition	Min.	Typ.	Max.	Unit
<b>VDD Section</b>						
$V_{DD-ON}$	Turn-On Threshold Voltage		14.5	16.0	17.5	V
$V_{DD-OFF}$	Turn-Off Threshold Voltage		6.75	7.75	8.75	V
$I_{DD-OP}$	Operating Current	Maximum Frequency, $C_{LOAD} = 1\text{ nF}$	3	4	5	mA
$I_{DD-ST}$	Startup Current	$V_{DD} = V_{DD-ON} - 0.16\text{ V}$		2	20	$\mu\text{A}$
$V_{OVP}$	$V_{DD}$ Over-Voltage-Protection		22.0	23.5	25.0	V
<b>Gate Section</b>						
$V_{OL}$	Output Voltage Low	$V_{DD}=20\text{ V}, I_{GATE}=-1\text{ mA}$			1.5	V
$V_{OH}$	Output Voltage High	$V_{DD}=10\text{ V}, I_{GATE}=+1\text{ mA}$	5			V
$I_{source}$	Peak Sourcing Current	$V_{DD} = 10 \sim 20\text{ V}$		60		mA
$I_{sink}$	Peak Sinking Current	$V_{DD} = 10 \sim 20\text{ V}$		180		mA
$t_r$	Rising Time	$C_{LOAD} = 1\text{ nF}$	100	150	200	ns
$t_f$	Falling Time	$C_{LOAD} = 1\text{ nF}$	20	60	100	ns
$V_{CLAMP}$	Output Clamp Voltage		12	15	18	V
<b>Oscillator Section</b>						
$f_{MAX-CC}$	Maximum Frequency in CC		60	65	70	kHz
$f_{MIN-CC}$	Minimum Frequency in CC		21.0	23.5	26.0	kHz
$V_{S_{MAX-CC}}$	$V_S$ for Maximum Frequency in CC	$f = f_{MAX} - 2\text{ kHz}$	2.25	2.35	2.45	V
$V_{S_{MIN-CC}}$	$V_S$ for Minimum Frequency in CC	$f = f_{MIN} + 2\text{ kHz}$	0.55	0.85	1.15	V
$t_{ON(MAX)}$	Maximum Turn-On Time		12	14	16	$\mu\text{s}$
<b>Current Sense Section</b>						
$V_{RV}$	Reference Voltage		2.475	2.500	2.525	V
$V_{CCR}$	EAI Voltage for Constant Current Regulation	$V_{CS} = 0.44\text{ V}$	2.38	2.43	2.48	V
$t_{LEB}$	Leading-Edge Blanking Time			300		ns
$t_{MIN}$	Minimum On Time in CC	$V_{COMI} = 0\text{ V}$		600		ns
$t_{PD}$	Propagation Delay to GATE		50	100	150	ns
$t_{dis-BNK}$	$t_{DIS}$ Blanking Time of $V_S$			1.5		$\mu\text{s}$
$I_{COMI-BNK}$	$V_S$ Current for COMI Blanking			100		$\mu\text{A}$
<b>Current-Error Amplifier Section</b>						
$G_m$	Transconductance			85		$\mu\text{mho}$
$I_{COMI-SINK}$	COMI Sink Current	$V_{EAI}=3\text{ V}, V_{COMI}=5\text{ V}$	28		38	$\mu\text{A}$
$I_{COMI-SOURCE}$	COMI Source Current	$V_{EAI}=2\text{ V}, V_{COMI}=0\text{ V}$	28		38	$\mu\text{A}$
$V_{COMI-HGH}$	COMI High Voltage	$V_{EAI}=2\text{ V}$	4.9			V
$V_{COMI-LOW}$	COMI Low Voltage	$V_{EAI}=3\text{ V}$			0.1	V

Continued on the following page...

## Electrical Characteristics

$V_{DD}=15\text{ V}$  and  $T_A=25^\circ\text{C}$  unless otherwise specified.

Symbol	Parameter	Condition	Min.	Typ.	Max.	Unit
<b>Over-Current Protection Section</b>						
$V_{OCP}$	$V_{CS}$ Threshold Voltage for OCP		0.60	0.67	0.74	V
$V_{LowOCP}$	$V_{CS}$ Threshold Voltage for Low OCP		0.13	0.18	0.23	V
$t_{startup}$	Startup Time			13		ms
$V_{LowOCP-EN}$	VS Threshold Voltage to Enable Low OCP level			0.40		V
$V_{LowOCP-DIS}$	VS Threshold Voltage to Disable Low OCP level			0.60		V
<b>Over-Temperature Protection Section</b>						
$T_{OTP}$	Threshold Temperature for OTP <sup>(3)</sup>		140	150	160	$^\circ\text{C}$
$T_{OTP-HYS}$	Restart Junction Temperature Hysteresis			10		$^\circ\text{C}$
<b>Dimming Section</b>						
$V_{DIM-LOW}$	Maximum $V_{DIM}$ at Low Dimming Angle Range		2.45	2.50	2.55	V
$V_{DIM-HIGH}$	Maximum $V_{DIM}$ at High Dimming Angle Range		3.43	3.50	3.57	V
$DS_{LOW}$	$V_{DIM}$ vs. $V_{cs,offset}$ Slope at Low Dimming Angle Range			0.19		V/V
$DS_{HIGH}$	$V_{DIM}$ vs. $V_{cs,offset}$ Slope at High Dimming Angle Range			0.58		V/V

**Note:**

- If over-temperature protection is activated, the power system enters Auto Recovery Mode and output is disabled. Device operation above the maximum junction temperature is NOT guaranteed.

## Typical Performance Characteristics

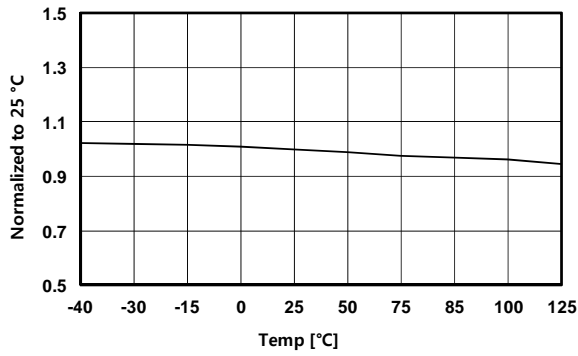

Figure 5.  $V_{DD-ON}$  vs. Temperature

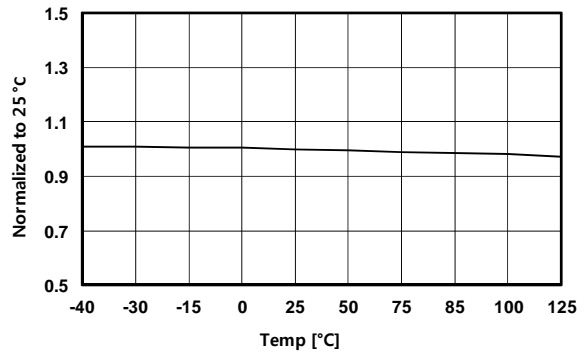

Figure 6.  $V_{DD-OFF}$  vs. Temperature

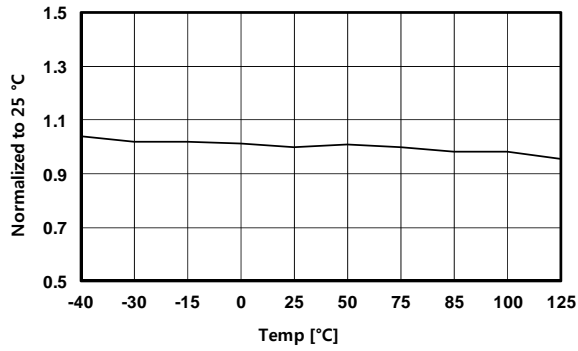

Figure 7.  $I_{DD-OP}$  vs. Temperature

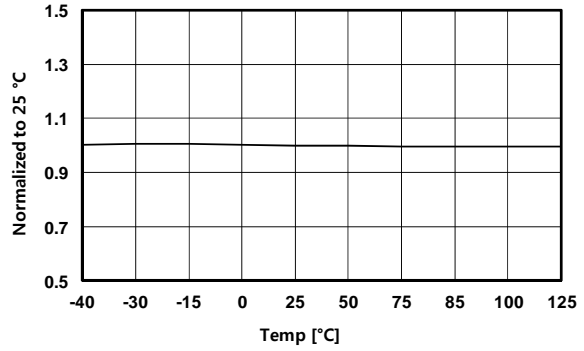

Figure 8.  $V_{OVP}$  vs. Temperature

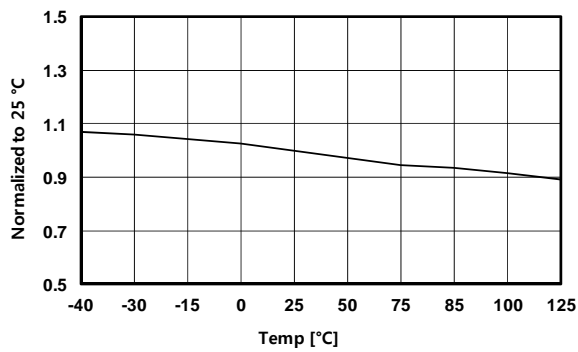

Figure 9.  $f_{MAX-CC}$  vs. Temperature

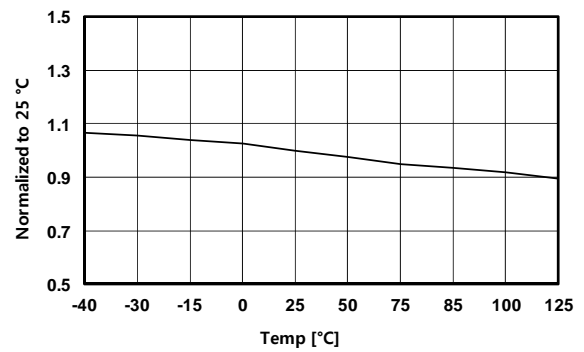

Figure 10.  $f_{MIN-CC}$  vs. Temperature

## Typical Performance Characteristics

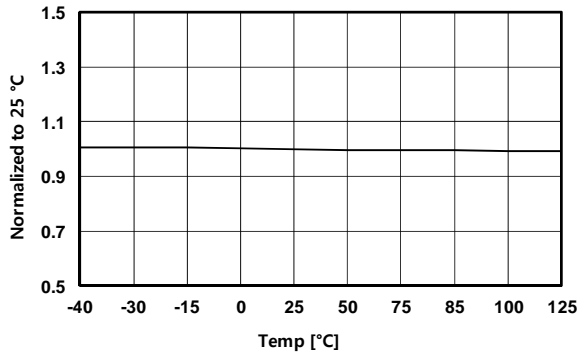

Figure 11.  $V_{RV}$  vs. Temperature

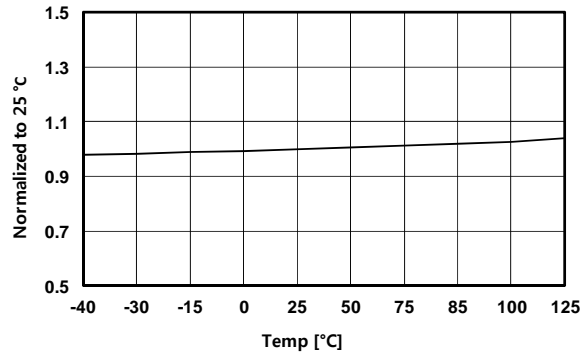

Figure 12.  $V_{CCR}$  vs. Temperature

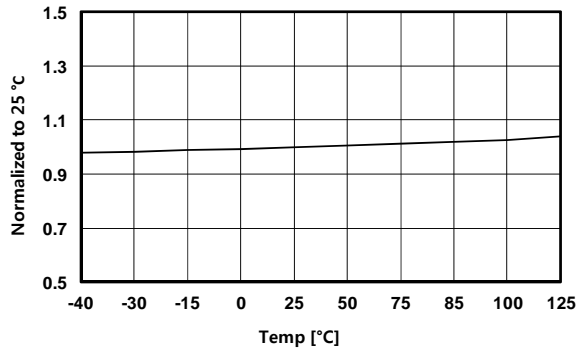

Figure 13.  $V_{OCP}$  vs. Temperature

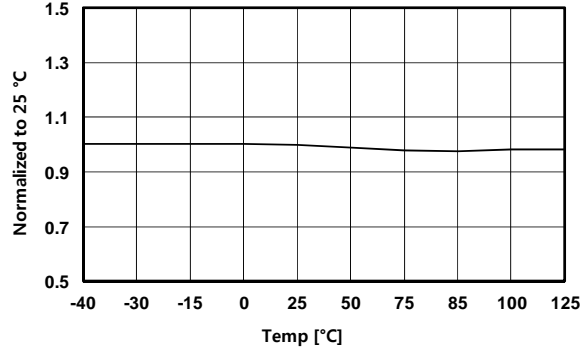

Figure 14.  $V_{OCP-Low}$  vs. Temperature

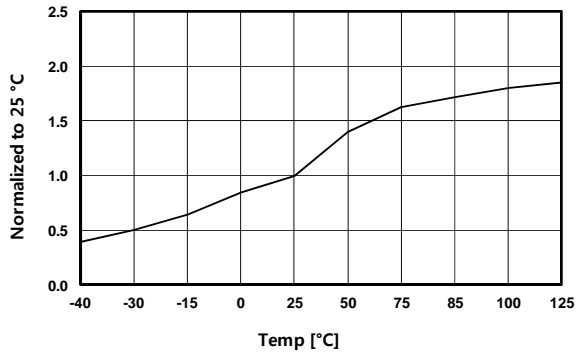

Figure 15.  $DS_{Low}$  vs. Temperature

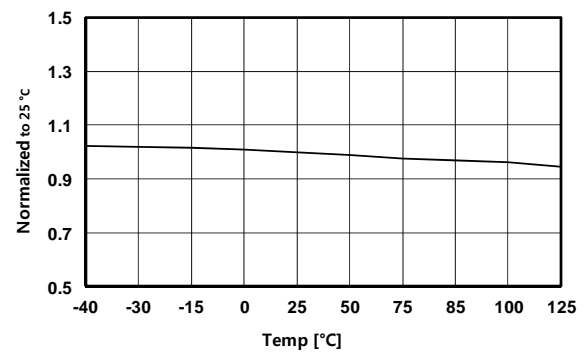

Figure 16.  $DS_{High}$  vs. Temperature

## Functional Description

FL7730 is AC-DC dimmable PWM controller for LED lighting applications. TRUECURRENT<sup>®</sup> technique and internal line compensation regulates accurate LED current independent of input voltage, output voltage, and magnetizing inductance variations. The TRIAC dim function block provides smooth brightness dimming control compatible with a conventional TRIAC dimmer. The linear frequency control in the oscillator reduces conduction loss and maintains DCM operation in a wide range of output voltages, which implements high power factor correction in a single-stage flyback topology. A variety of protections; such as short-LED protection, open-LED protection, over-temperature protection, and cycle-by-cycle current limitation; stabilize system operation and protect external components.

### Startup

Powering at startup is slow due to the low feedback loop bandwidth in the PFC converter. To boost power during startup, an internal oscillator counts 12 ms to define Startup Mode. During Startup Mode, turn-on time is determined by Current Mode control with a 0.2 V CS voltage limit and transconductance becomes 14 times larger, as shown in Figure 17. After Startup Mode, turn-on time is controlled by Voltage Mode using the COMI voltage and the error amplifier transconductance is reduced to 85  $\mu$ mho.

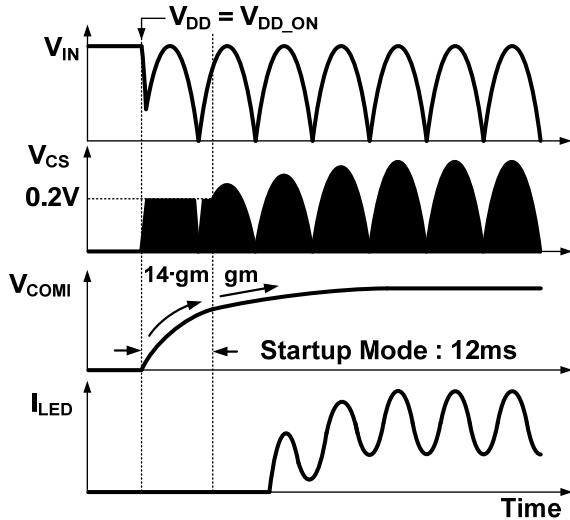

Figure 17. Startup Sequence

### Constant-Current Regulation

The output current is estimated using the peak drain current and inductor current discharge time because output current is same as the average of the diode current in steady state. The peak value of the drain current is determined by the CS pin. The inductor discharge time ( $t_{DIS}$ ) is sensed by a  $t_{DIS}$  detector. Using three sources of information (peak drain current, inductor discharging time, and operating switching period), a TRUECURRENT<sup>®</sup> block calculates estimated output current. The output of the calculation is compared with an internal precise reference to generate

an error voltage ( $V_{COMI}$ ), which determines turn-on time in Voltage Mode control. With Fairchild's innovative TRUECURRENT<sup>®</sup> technique, constant current output can be precisely controlled.

### PFC and THD

In a conventional boost converter, Boundary Conduction Mode (BCM) is generally used to keep input current in phase with input voltage for Power Factor (PF) and Total Harmonic Distortion (THD). However, in flyback / buck boost topology, constant turn-on time and constant frequency in Discontinuous Conduction Mode (DCM) can implement high PF and low THD, as shown in Figure 18. Constant turn-on time is maintained by an internal error amplifier and a large external capacitor (typically  $>1 \mu$ F) at the COMI pin. Constant frequency and DCM operation are managed by linear frequency control.

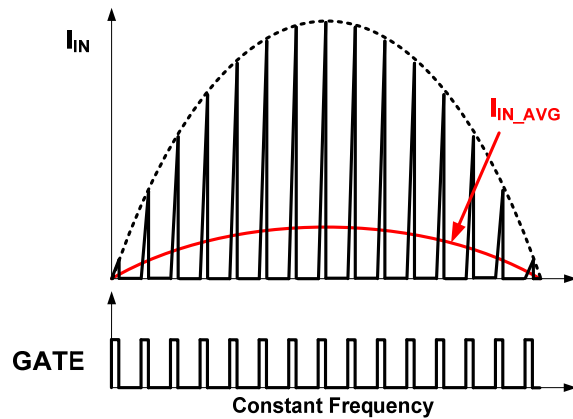

Figure 18. Input Current and Switching

### Linear Frequency Control

DCM should be guaranteed for high power factor in flyback topology. To maintain DCM in the wide range of output voltage, frequency is linearly adjusted by output voltage in linear frequency control. Output voltage is detected by auxiliary winding and resistive divider connected to the VS pin, as shown in Figure 19.

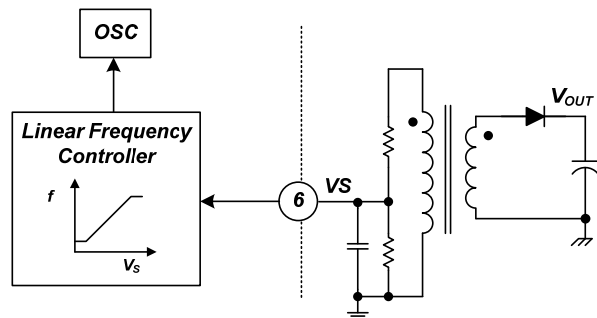

Figure 19. Linear Frequency Control

When output voltage decreases, secondary diode conduction time is increased and the linear frequency control lengthens switching period, which retains DCM operation in the wide output voltage range, as shown in Figure 20. The frequency control lowers primary rms current for better power efficiency in full-load condition.

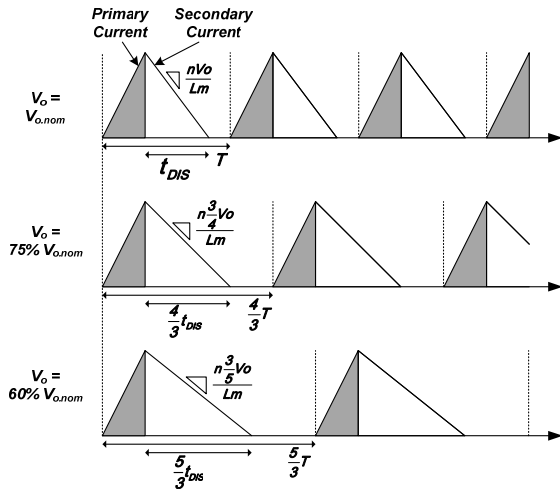

Figure 20. Primary and Secondary Current

### BCM Control

The end of secondary diode conduction time can be over a switching period set by linear frequency control. In this case, FL7730 doesn't allow CCM and operation mode changes from DCM to BCM. Therefore, magnetizing inductance can be largely designed to add BCM for better efficiency if PF and THD meet specification with enough margin.

### Dimming Control

TRIAC dimmable control is implemented by simple and noise-immune external passive components and an internal dimming function block. Figure 21 shows dimming angle detection and the internal dimming control block. Dimming angle is sensed by Zener diode and Zener diode voltage is divided by two resistors ( $R_{D1}$  and  $R_{D2}$ ) to fit the sensing range of the DIM pin. The detected signal is filtered by capacitor  $C_D$  to provide DC voltage into the DIM pin. The internal dimming control adds  $CS_{offset}$  to the peak current value as the input of TRUECURRENT<sup>®</sup> calculation block. When the dimming angle is small, lowered DIM voltage increases  $CS_{offset}$ , which makes calculated output current larger and reduces turn-on time to dim the LED brightness.

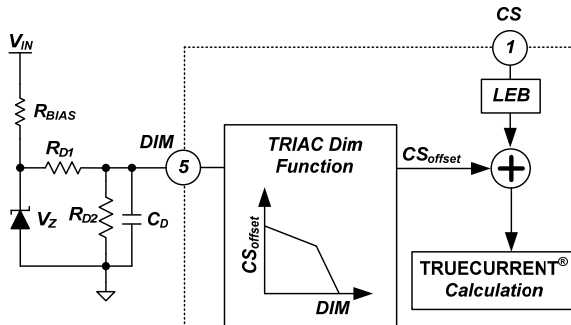

Figure 21. Dimming Control Schematic

To disable the dimming function, a 1 nF filter capacitor can be added at the DIM pin. An internal current source ( $\sim 7.5 \mu A$ ) on the DIM pin charges the filter capacitor up to 4 V. FL7730 goes into IC Test Mode when DIM voltage is over 6 V; so the maximum DIM voltage should be limited to less than 5 V.

### Short-LED Protection

In a short-LED condition, the switching MOSFET and secondary diode are usually stressed by the high powering current. However, FL7730 changes the OCP level in a short-LED condition. When  $V_S$  is lower than 0.4 V, the OCP level becomes down to 0.2 V from 0.7 V, as shown in Figure 22, so that powering is limited and external components' current stress is relieved.

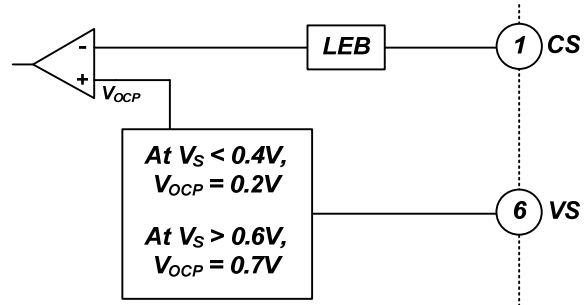

Figure 22. Internal OCP Block

Figure 23 shows operational waveforms in short-LED condition. Output voltage is quickly lowered to 0 V after the LED-short event. The reflected auxiliary voltage is also 0 V, making  $V_S$  less than 0.4 V. The 0.2 V OCP level limits primary-side current and  $V_{DD}$  hiccups up and down in between UVLO hysteresis.

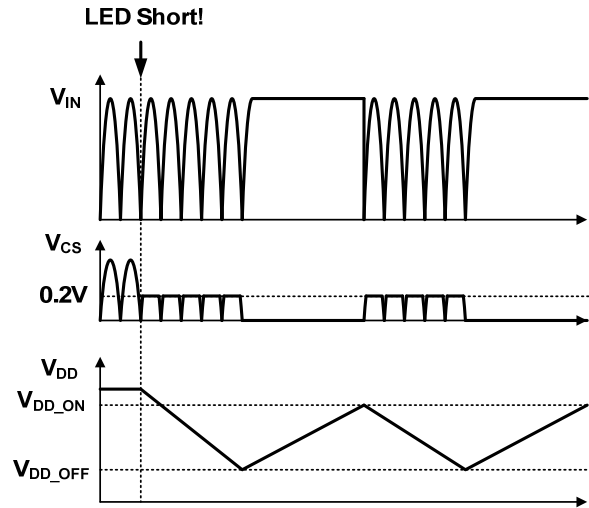

Figure 23. Waveforms in Short-LED Condition

### Open-LED Protection

FL7730 protects external components, such as diodes and capacitors on the secondary side, in the open-LED condition. During switch-off, the  $V_{DD}$  capacitor is charged up to the auxiliary winding voltage, which is applied as the reflected output voltage. Because the  $V_{DD}$  voltage has output voltage information, the internal voltage comparator on the VDD pin can trigger output Over-Voltage Protection (OVP), as shown in Figure 24. When at least one LED is open-circuited, output load impedance becomes very high and output capacitor is quickly charged up to  $V_{OVP} \times N_s / N_a$ . Then switching is shut down and  $V_{DD}$  block goes into "Hiccup" Mode until the open-LED condition is removed, shown in Figure 25.

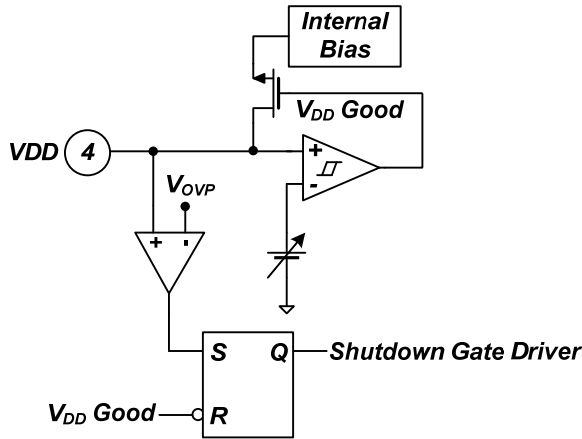

Figure 24. Internal OVP Block

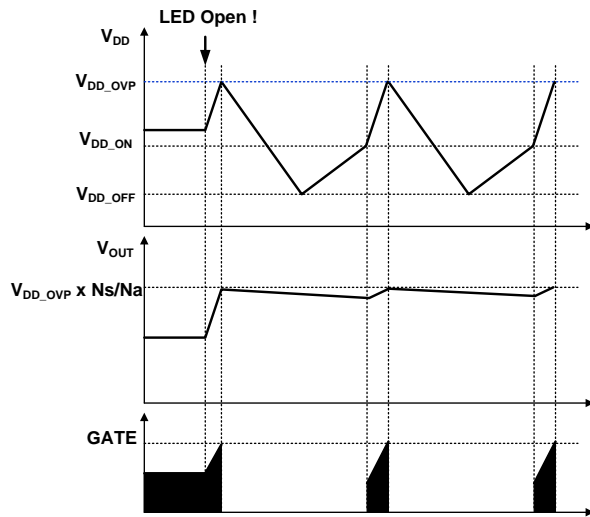

Figure 25. Waveforms in Open-LED Condition

### Under-Voltage Lockout (UVLO)

The turn-on and turn-off thresholds are fixed internally at 16 V and 7.5 V, respectively. During startup, the  $V_{DD}$  capacitor must be charged to 16 V through the startup resistor to enable the FL7730. The  $V_{DD}$  capacitor continues to supply  $V_{DD}$  until power can be delivered from the auxiliary winding of the main transformer.  $V_{DD}$  must not drop below 7.5 V during this startup process. This UVLO hysteresis window ensures that the  $V_{DD}$  capacitor is adequate to supply  $V_{DD}$  during startup.

### Over-Temperature Protection (OTP)

The built-in temperature-sensing circuit shuts down PWM output if the junction temperature exceeds 150°C. While PWM output is shut down, the  $V_{DD}$  voltage gradually drops to the UVLO voltage. Some of the internal circuits are shut down and  $V_{DD}$  gradually starts increasing again. When  $V_{DD}$  reaches 16 V, all the internal circuits start operating. If the junction temperature is still higher than 140°C, the PWM controller shuts down immediately.

### Physical Dimensions

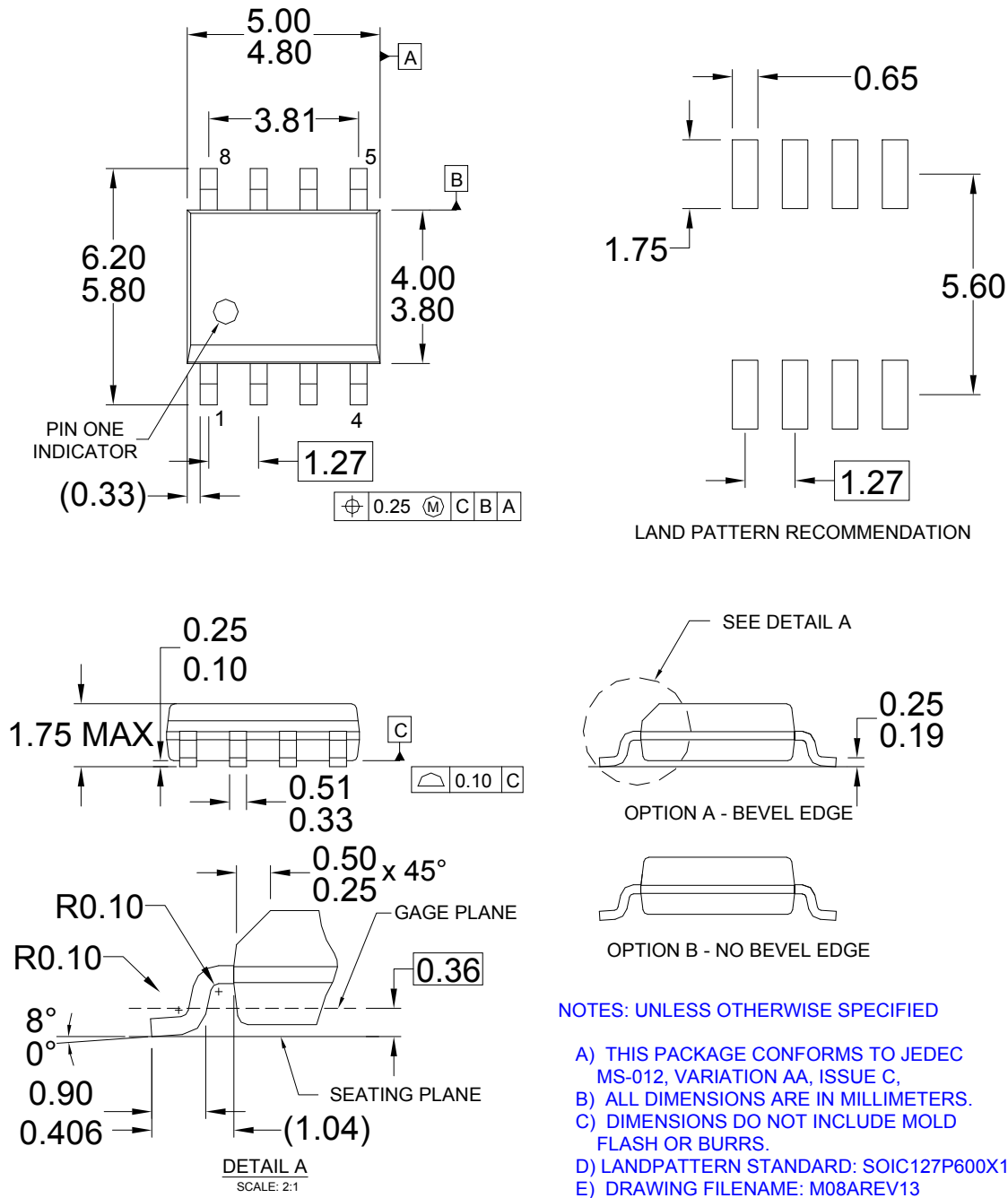

**Figure 26. 8-Lead, SOIC, JEDEC MS-012, .150" Narrow Body**

Package drawings are provided as a service to customers considering Fairchild components. Drawings may change in any manner without notice. Please note the revision and/or date on the drawing and contact a Fairchild Semiconductor representative to verify or obtain the most recent revision. Package specifications do not expand the terms of Fairchild's worldwide terms and conditions, specifically the warranty therein, which covers Fairchild products.

ON Semiconductor and  are trademarks of Semiconductor Components Industries, LLC dba ON Semiconductor or its subsidiaries in the United States and/or other countries. ON Semiconductor owns the rights to a number of patents, trademarks, copyrights, trade secrets, and other intellectual property. A listing of ON Semiconductor's product/patent coverage may be accessed at [www.onsemi.com/site/pdf/Patent-Marking.pdf](http://www.onsemi.com/site/pdf/Patent-Marking.pdf). ON Semiconductor reserves the right to make changes without further notice to any products herein. ON Semiconductor makes no warranty, representation or guarantee regarding the suitability of its products for any particular purpose, nor does ON Semiconductor assume any liability arising out of the application or use of any product or circuit, and specifically disclaims any and all liability, including without limitation special, consequential or incidental damages. Buyer is responsible for its products and applications using ON Semiconductor products, including compliance with all laws, regulations and safety requirements or standards, regardless of any support or applications information provided by ON Semiconductor. "Typical" parameters which may be provided in ON Semiconductor data sheets and/or specifications can and do vary in different applications and actual performance may vary over time. All operating parameters, including "Typicals" must be validated for each customer application by customer's technical experts. ON Semiconductor does not convey any license under its patent rights nor the rights of others. ON Semiconductor products are not designed, intended, or authorized for use as a critical component in life support systems or any FDA Class 3 medical devices or medical devices with a same or similar classification in a foreign jurisdiction or any devices intended for implantation in the human body. Should Buyer purchase or use ON Semiconductor products for any such unintended or unauthorized application, Buyer shall indemnify and hold ON Semiconductor and its officers, employees, subsidiaries, affiliates, and distributors harmless against all claims, costs, damages, and expenses, and reasonable attorney fees arising out of, directly or indirectly, any claim of personal injury or death associated with such unintended or unauthorized use, even if such claim alleges that ON Semiconductor was negligent regarding the design or manufacture of the part. ON Semiconductor is an Equal Opportunity/Affirmative Action Employer. This literature is subject to all applicable copyright laws and is not for resale in any manner.

## PUBLICATION ORDERING INFORMATION

### LITERATURE FULFILLMENT:

Email Requests to: [orderlit@onsemi.com](mailto:orderlit@onsemi.com)

ON Semiconductor Website: [www.onsemi.com](http://www.onsemi.com)

### TECHNICAL SUPPORT

North American Technical Support:  
Voice Mail: 1 800-282-9855 Toll Free USA/Canada  
Phone: 011 421 33 790 2910

Europe, Middle East and Africa Technical Support:

Phone: 00421 33 790 2910

For additional information, please contact your local Sales Representative