

SPECIFICATIONS	
CONTACT MATERIAL/PLATING (M12)	BRASS/NICKEL
CONTACT MATERIAL/PLATING (RJ45SF)	COPPER/GOLD
COUPLING NUT MATERIAL/PLATING (M12)	ZINC/NICKEL
HOUSING MATERIAL/PLATING	ZINC/NICKEL
RATED CURRENT [A]	1.0 A @ 40°C
RATED VOLTAGE [V]	57 VDC
PROTECTION CLASS	IP65/67 (M12), IP20 (RJ45SF)

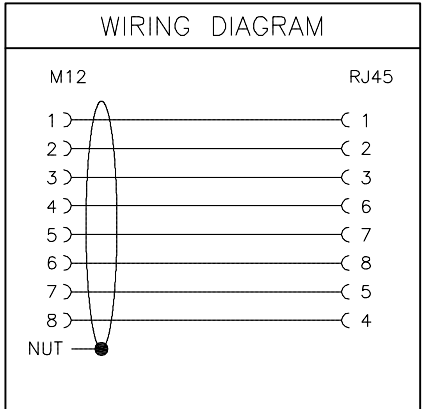
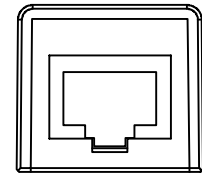
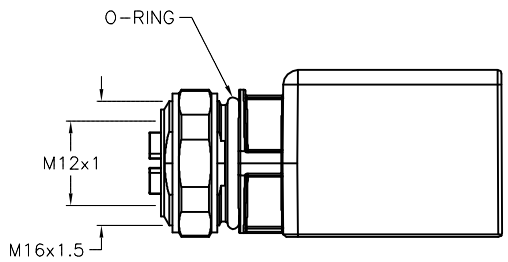
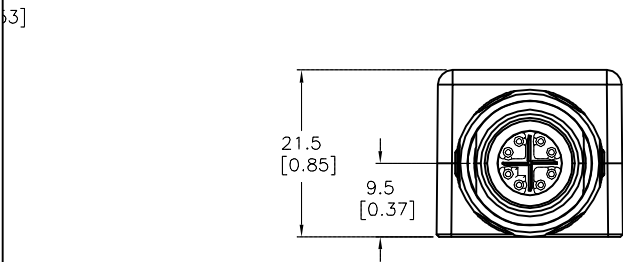
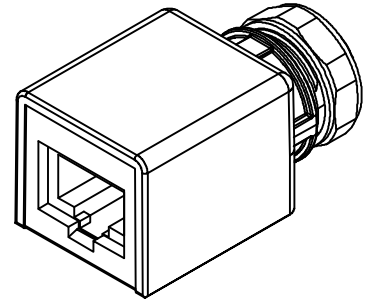
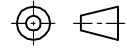

SOURCE DRAWING - FOR REFERENCE ONLY

RELATED DOCUMENTS 1. 2. 3. 4.	3RD ANGLE PROJECTION 	THIS DRAWING IS CONFIDENTIAL AND THE PROPERTY OF TURCK INC. USE OF THIS DOCUMENT WITHOUT WRITTEN PERMISSION IS PROHIBITED.		<b>TURCK INC</b> <i>High Technology Sensors and Automation Controls</i> 3000 CAMPUS DRIVE MINNEAPOLIS, MN 55441 1-800-544-7769 (763) 553-7300 (763) 553-0708 fax turck.com	
		MATERIAL  SEE SPECIFICATIONS	DRFT RDS APVD A.A.	DATE 07/01/13 SCALE 1=1.0	DESCRIPTION FKSDX RJ45SF 86/ST
FINISH  SEE SPECIFICATIONS	ALL DIMENSIONS DISPLAYED ON THIS DRAWING ARE FOR REFERENCE ONLY	UNIT OF MEASUREMENT <b>MILLIMETER [ INCH ]</b>		IDENTIFICATION NO. U2-21790	
CONTACT TURCK FOR MORE INFORMATION		DO NOT SCALE THIS DRAWING		REV C	
FILE: U2-21790		SHEET 1 OF 1			

C	UPDATE M12 END VIEW	RDS	07/25/14	46536
REV	DESCRIPTION	BY	DATE	ECO NO.