

SPECIFICATIONS	
CONTACT CARRIER MATERIAL/COLOR	NYLON OR TPU/BLACK
CONTACT MATERIAL/PLATING	BRASS/GOLD
HOUSING, LOCKNUT/PLATING	BRASS/NICKEL
RATED CURRENT [A]	2.0 A
RATED VOLTAGE [V]	60VAC/75VDC
NUMBER OF CONDUCTORS [AWG]	SOLDER CUPS
TEMPERATURE RANGE	-40°C to +105°C (-40°F to +221°F)
PROTECTION CLASS	MEETS NEMA 1,3,4,6P AND IEC IP68

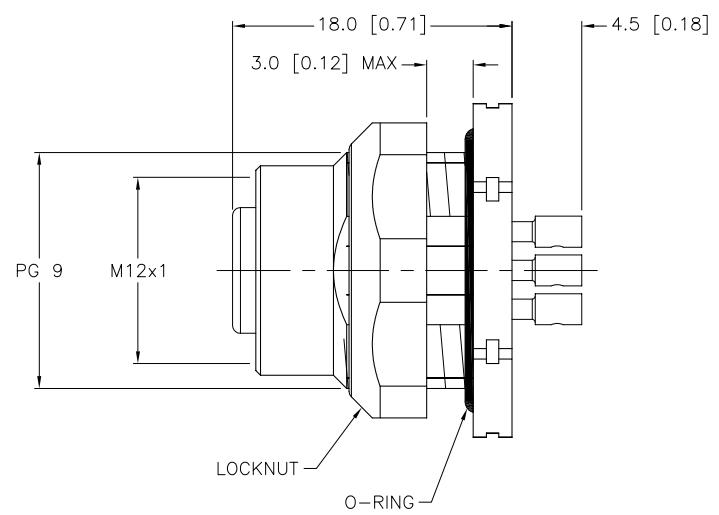
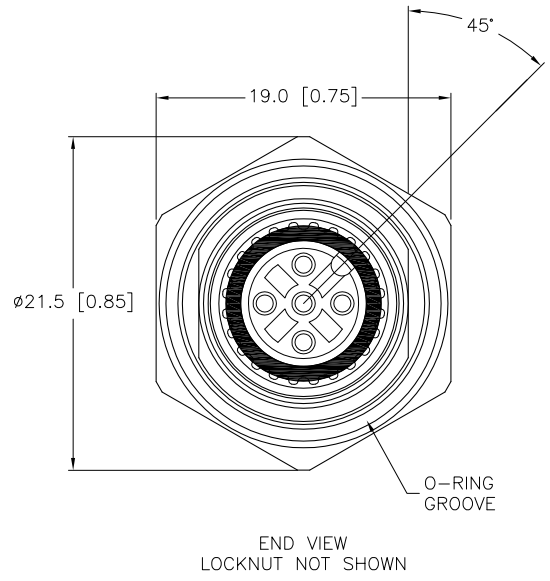

SOURCE DRAWING - FOR REFERENCE ONLY

RELATED DOCUMENTS		3RD ANGLE PROJECTION		THIS DRAWING IS PROPERTY OF TURCK INC. USE OF THIS DOCUMENT WITHOUT WRITTEN PERMISSION IS PROHIBITED.		<b>TURCK INC</b> High Technology Sensors and Automation Controls 3000 CAMPUS DRIVE MINNEAPOLIS, MN 55441 1-800-544-7769 (763) 553-7300 (763) 553-0708 fax turck.com	
1.			DRFT RWC DSGN	DATE 08/17/07	DESCRIPTION FKFDL 4.5		
2.				SCALE 1=.5			
3.		ALL DIMENSIONS DISPLAYED ON THIS DRAWING ARE FOR REFERENCE ONLY  CONTACT TURCK FOR MORE INFORMATION	UNIT OF MEASUREMENT <b>MILLIMETER [ INCH ]</b>		IDENTIFICATION NO. U4509-1		REV B
4.			DO NOT SCALE THIS DRAWING		FILE: U4509-1		SHEET 1 OF 1
MATERIAL		SEE SPECIFICATIONS					
FINISH		SEE SPECIFICATIONS					

B	DRAWING PROCESSED AS PART OF ECO 33971	CBM	04/07/11	33971
REV	DESCRIPTION	BY	DATE	ECO NO.