

Sep.1.2021 Copyright 2021 HIROSE ELECTRIC CO., LTD. All Rights Reserved.  
In case of consideration for using Automotive equipment / device which demand high reliability, kindly contact our sales window correspondents.

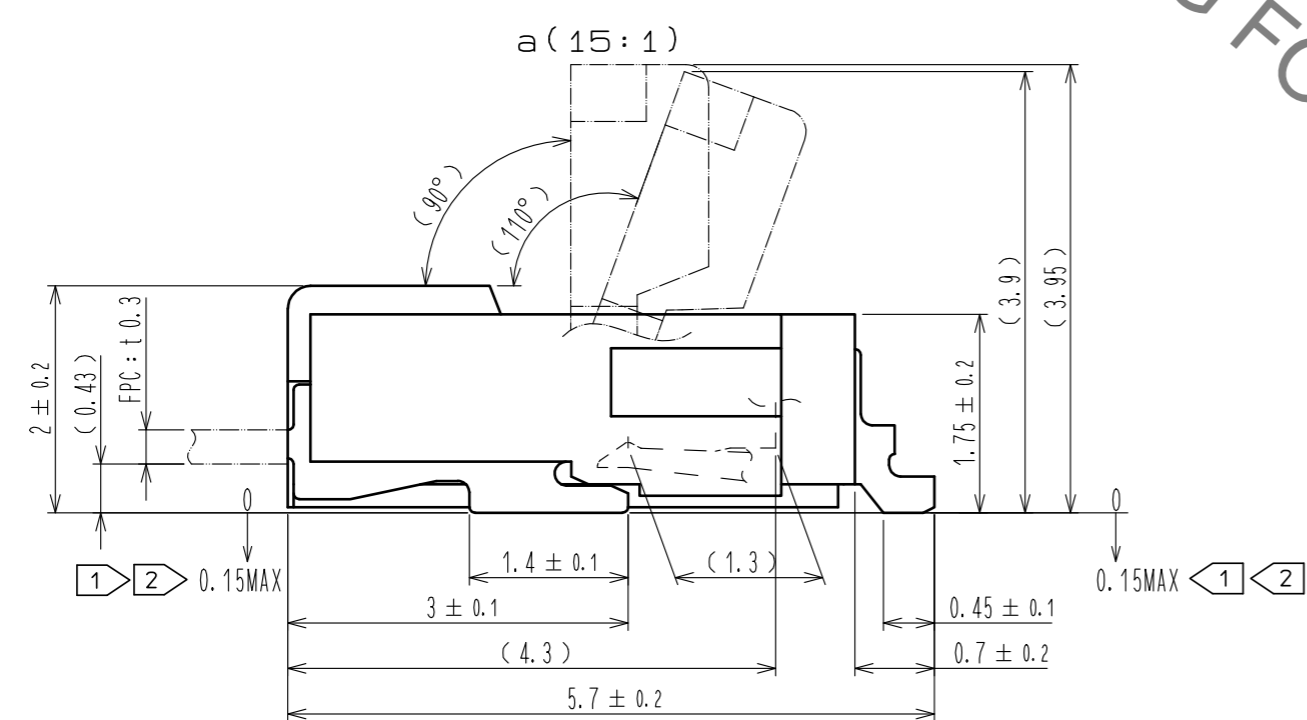
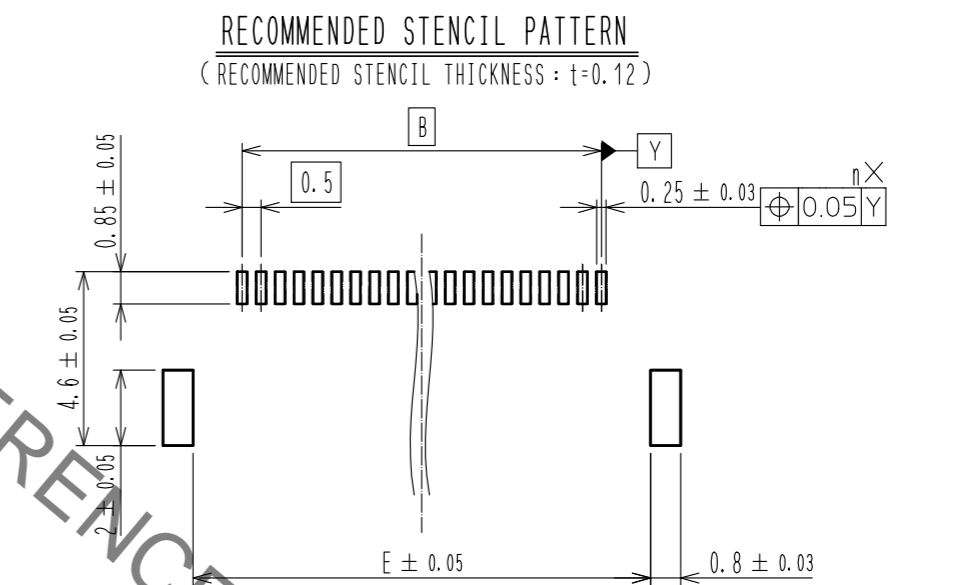
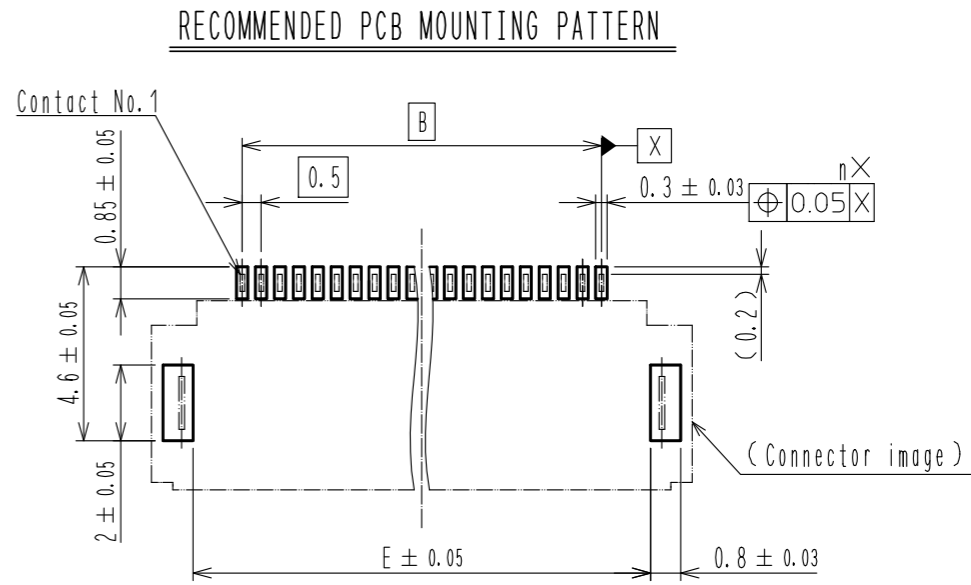
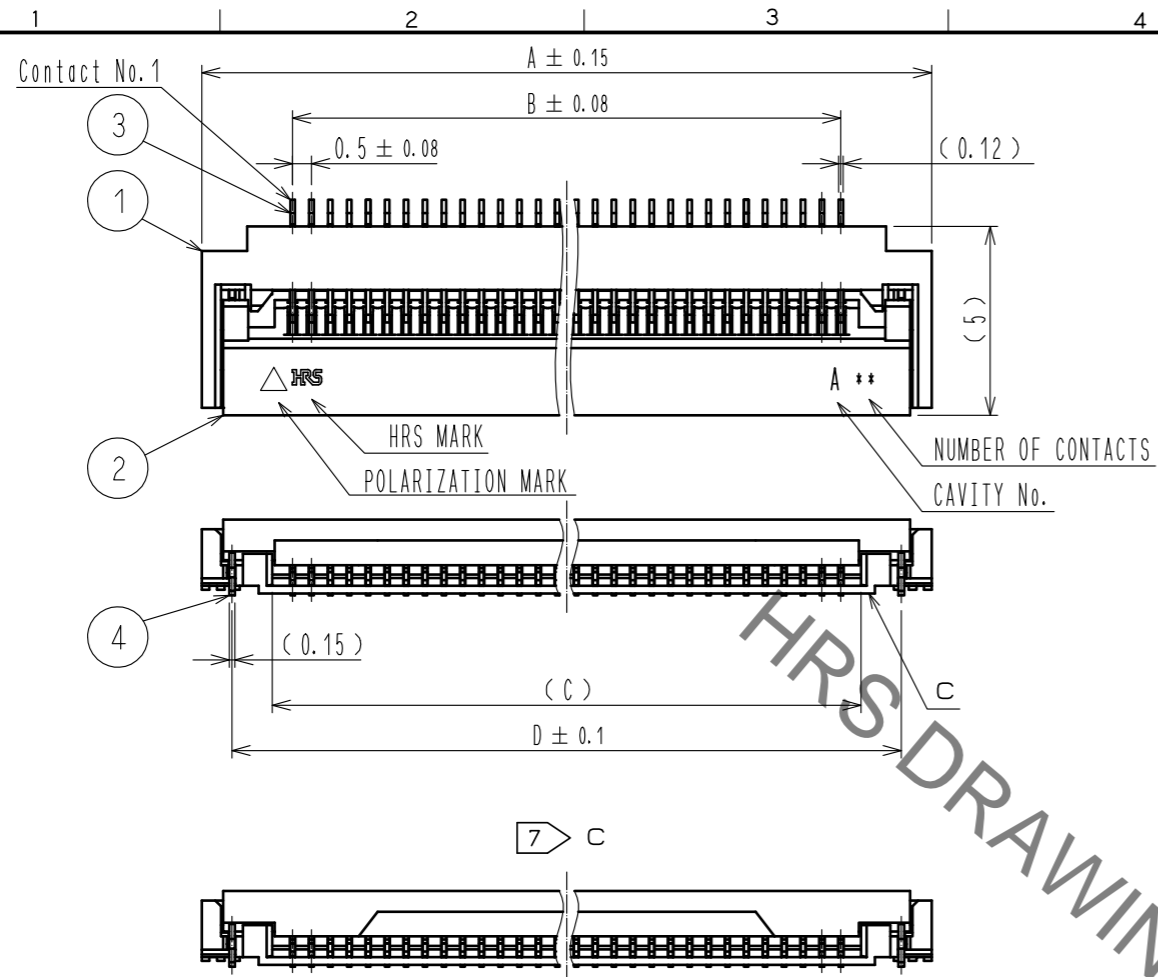

- NOTES
- 1 Lead CO-PLANARITY including reinforced metal fittings shall be 0.1 MAX.
  - 2 Dimension: from reference b.
  3. To be delivered with tape and reel packages.
  4. Note that preventive hole for sink mark could be added for improvement.
  5. The quality remains good. Even with the dark spots, which could occasionally occur molded plastics.
  6. This product satisfies halogen free requirements defined as 900ppm maximum chlorine, 900ppm maximum bromine, and 1500ppm maximum total of chlorine and bromine.
  - 7 Shows actuator configuration of 60 pos.
  8. 'n' represents the number of contacts.

4	BRASS (PLATED MATERIAL)	TIN PLATING(REFLOW FINISHED) 1#MMIN OVER COPPER 0.3#MMIN	8	(CONNECTOR)	
3	PHOSPHOR BRONZE	(CONTACT AREA, LEAD) GOLD 0.03#MMIN OVER NICKEL 1#MMIN (OTHER) NICKEL PLATING 1#MMIN	7	POLYSTYRENE	
2	LCP	BLACK UL94V-0	6	POLYESTER	
1	LCP	GRAY UL94V-0	5	POLYSTYRENE	
NO.	MATERIAL	FINISH . REMARKS	NO.	MATERIAL	FINISH . REMARKS
UNITS mm		SCALE 5 : 1	COUNT 4	DESCRIPTION OF REVISIONS DIS-F-00000381	
DESIGNED HK. KINOUCHI			CHECKED HS. SAKAMOTO		
DATE 15.06.24			DRAWING NO. EDC3-328248-00		
APPROVED : MO. ISHIDA 10.05.13			PART NO. FH52-**S-0.5SH		
CHECKED : NM. NISHIMATSU 10.05.13			CODE NO. CL580		
DESIGNED : YS. EBI 10.05.12					
DRAWN : YS. EBI 10.05.12					

Sep.1.2021 Copyright 2021 HIROSE ELECTRIC CO., LTD. All Rights Reserved.  
In case of consideration for using Automotive equipment / device which demand high reliability, kindly contact our sales window correspondents.

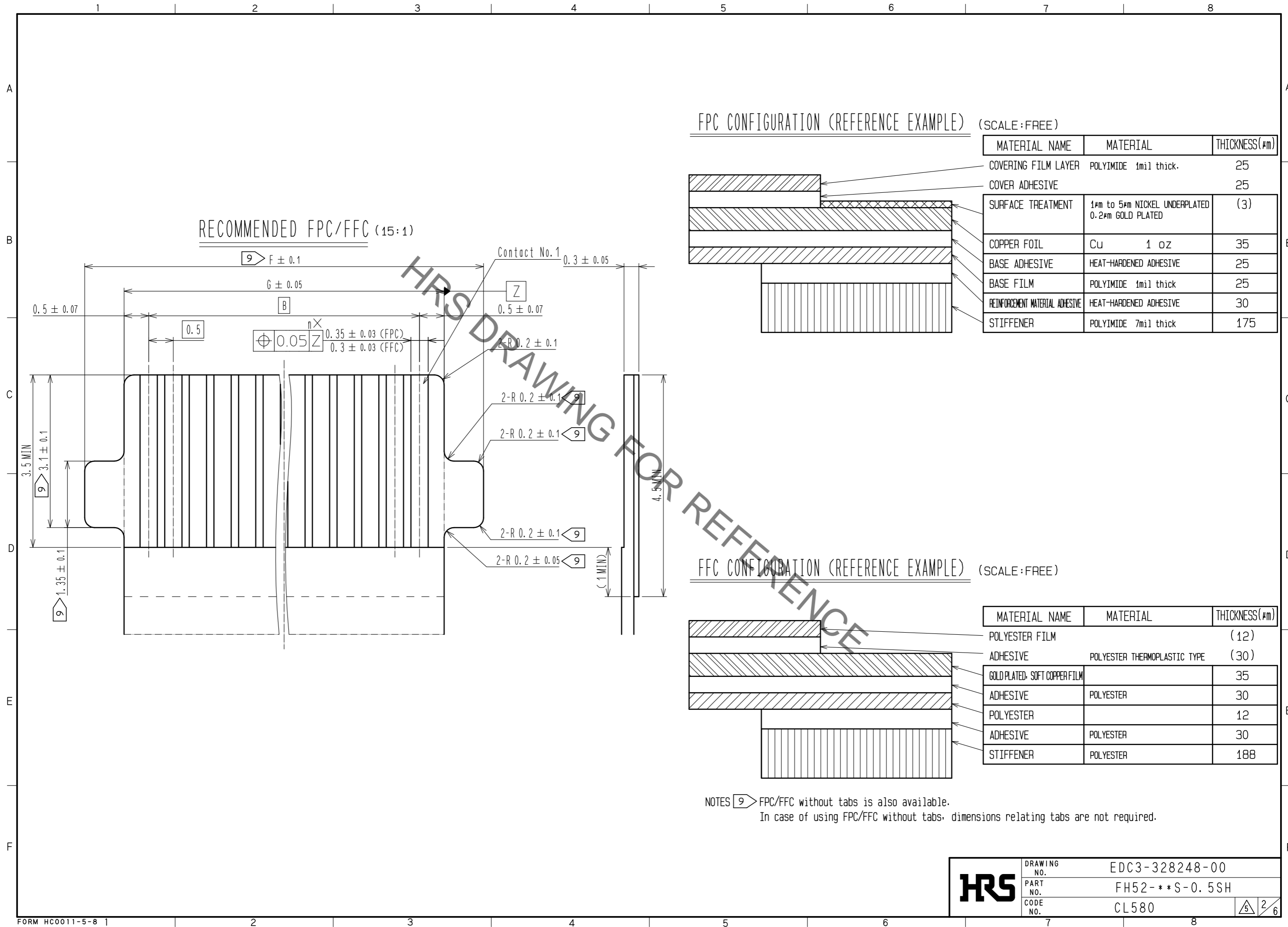

**RECOMMENDED FPC/FFC (15:1)**

**FPC CONFIGURATION (REFERENCE EXAMPLE) (SCALE:FREE)**

MATERIAL NAME	MATERIAL	THICKNESS(#m)
COVERING FILM LAYER	POLYIMIDE 1mil thick.	25
COVER ADHESIVE		25
SURFACE TREATMENT	1#m to 5#m NICKEL UNDERPLATED 0.2#m GOLD PLATED	(3)
COPPER FOIL	CU 1 oz	35
BASE ADHESIVE	HEAT-HARDENED ADHESIVE	25
BASE FILM	POLYIMIDE 1mil thick	25
REINFORCEMENT MATERIAL ADHESIVE	HEAT-HARDENED ADHESIVE	30
STIFFENER	POLYIMIDE 7mil thick	175

**FFC CONFIGURATION (REFERENCE EXAMPLE) (SCALE:FREE)**

MATERIAL NAME	MATERIAL	THICKNESS(#m)
POLYESTER FILM		(12)
ADHESIVE	POLYESTER THERMOPLASTIC TYPE	(30)
GOLD PLATED- SOFT COPPER FILM		35
ADHESIVE	POLYESTER	30
POLYESTER		12
ADHESIVE	POLYESTER	30
STIFFENER	POLYESTER	188

NOTES 9 FPC/FFC without tabs is also available.  
In case of using FPC/FFC without tabs, dimensions relating tabs are not required.

<b>HRS</b>	DRAWING NO.	EDC3-328248-00
	PART NO.	FH52-***S-0.5SH
	CODE NO.	CL580

Sep.1.2021 Copyright 2021 HIROSE ELECTRIC CO., LTD. All Rights Reserved.  
In case of consideration for using Automotive equipment / device which demand high reliability, kindly contact our sales window correspondents.

EMBOSSED CARRIER TAPE DIMENSION (2:1)

REEL DIMENSIONS (No Scale)

TAPE WIDTH : 24mm MAX

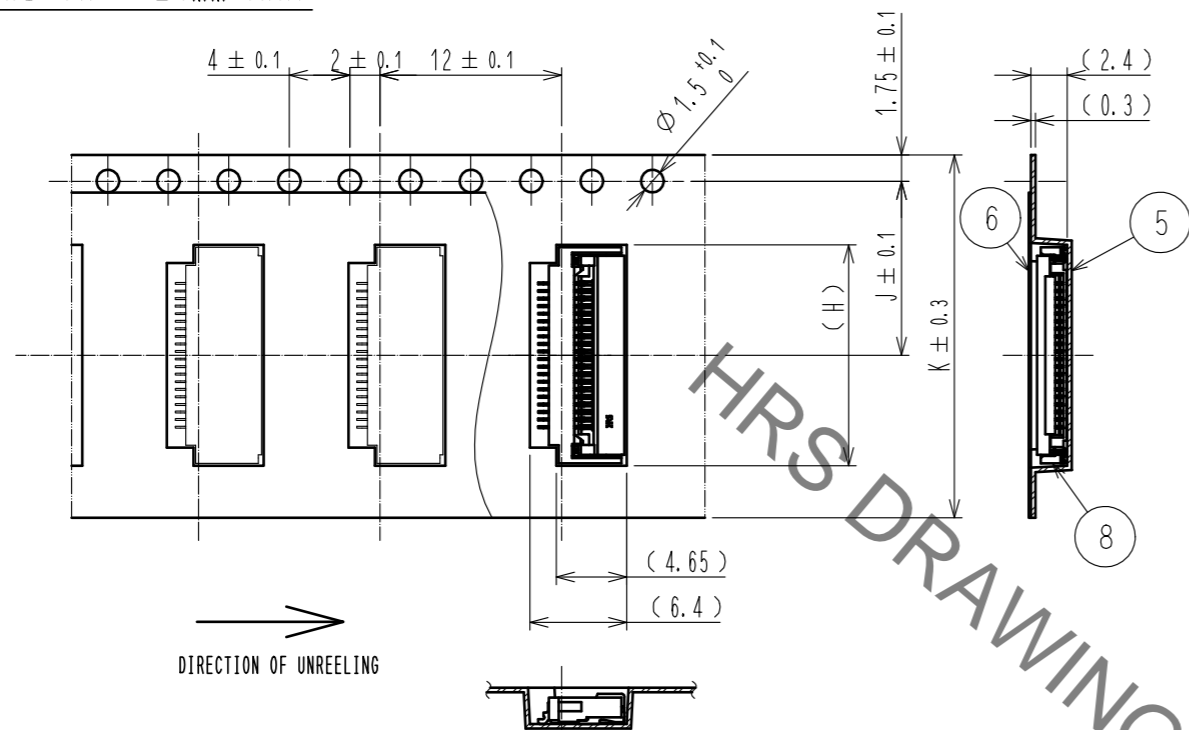

TAPE WIDTH : 32mm MIN

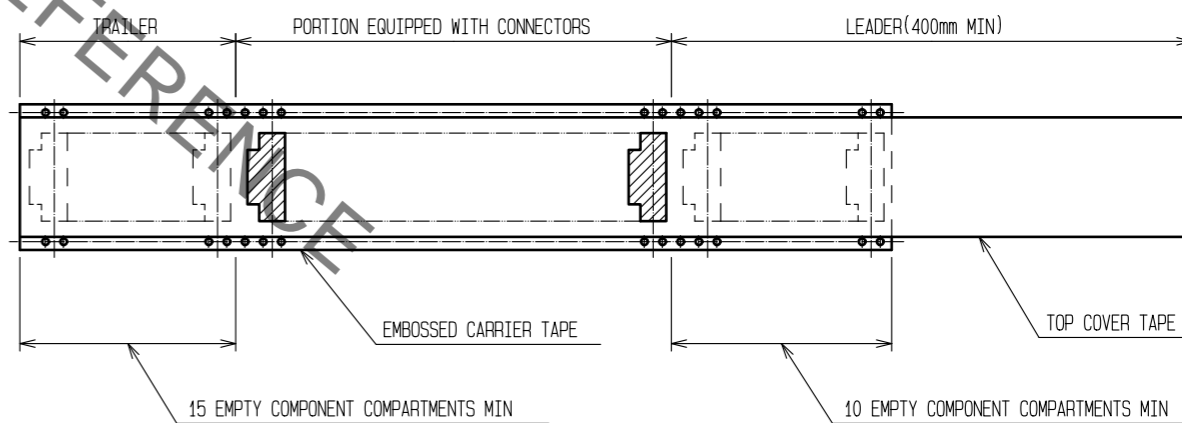
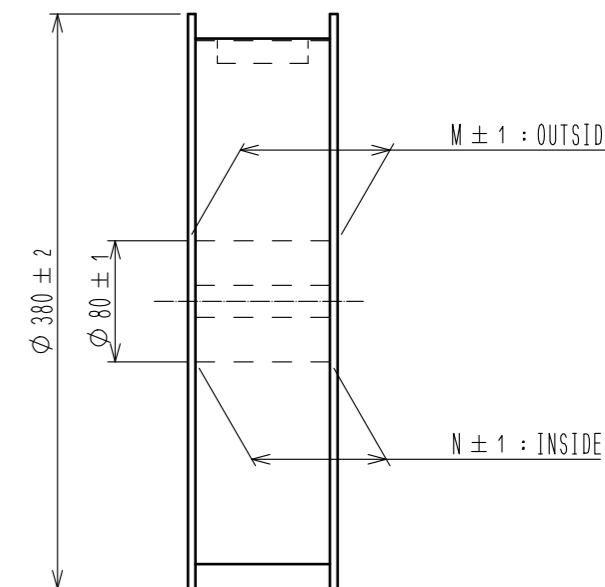
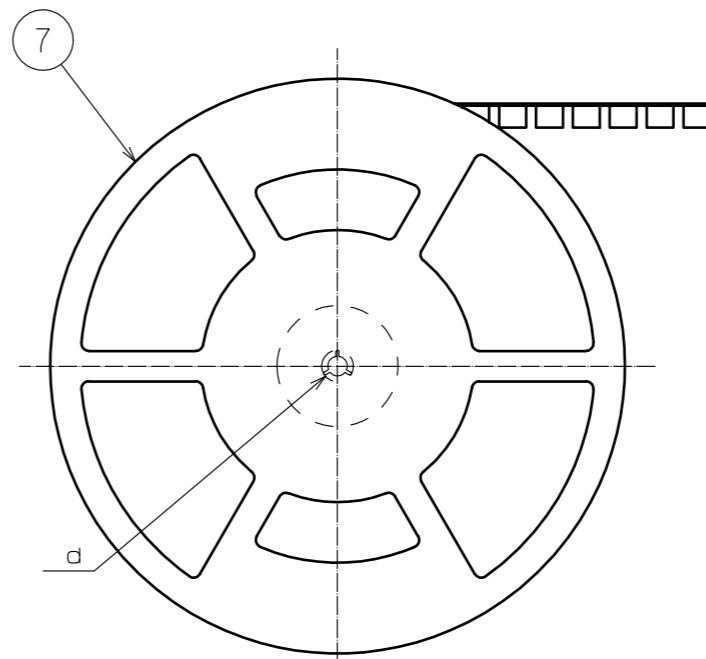
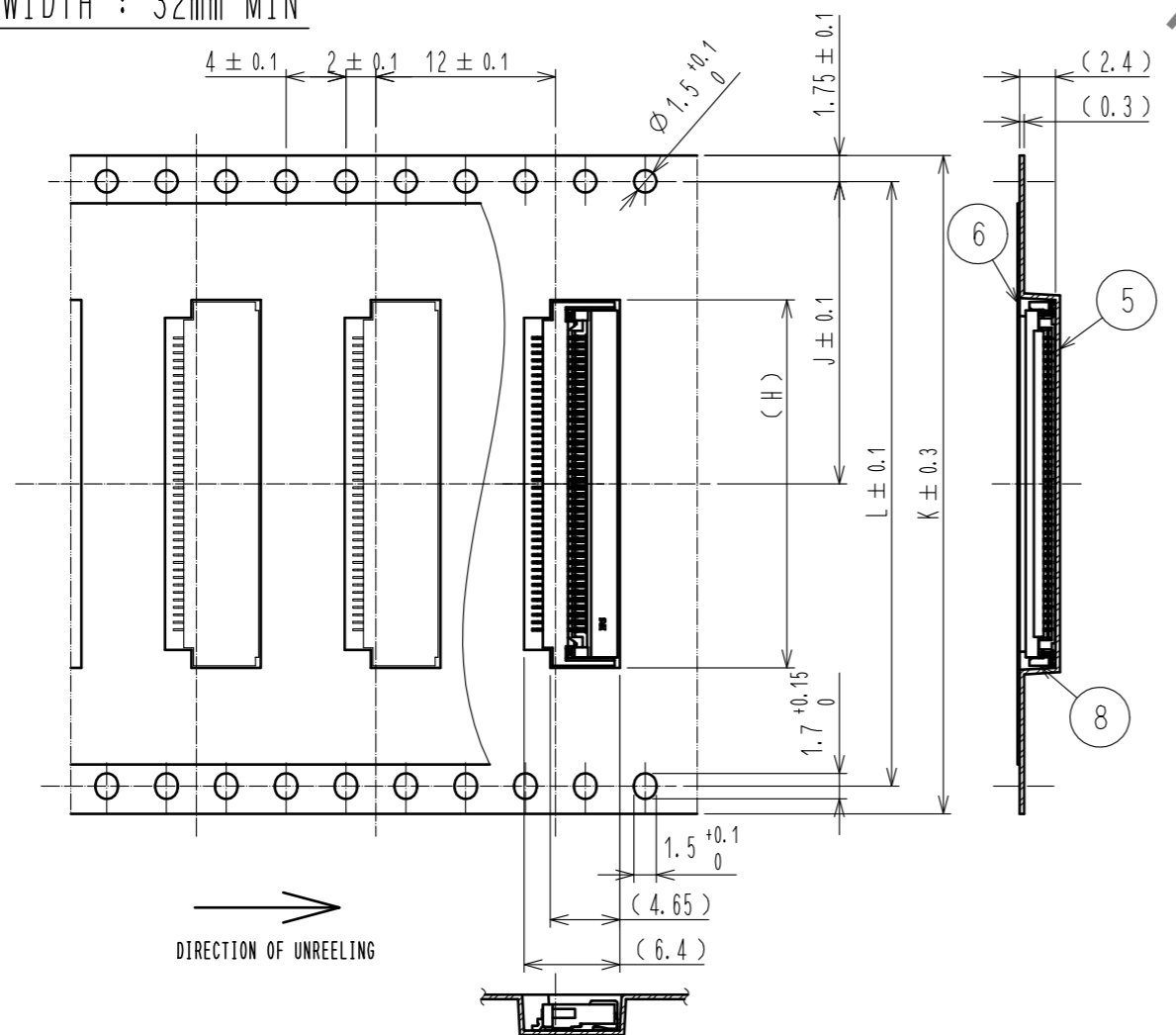

- NOTES
10. The dimension in parentheses are for reference.
  11. 1 reel : 3000 connectors.
  12. Refer to JIS C 0806. (Packaging of components for automatic handling.)

<DRAWING FOR PACKING>

<b>HRS</b>	DRAWING NO.	EDC3-328248-00
	PART NO.	FH52-***S-0.5SH
	CODE NO.	CL580
		3/6

Sep.1.2021 Copyright 2021 HIROSE ELECTRIC CO., LTD. All Rights Reserved.  
In case of consideration for using Automotive equipment / device which demand high reliability, kindly contact our sales window correspondents.

PART NO.	CODE NO.	NUMBER OF CONTACT	DIMENSION OF CONNECTOR, LAND PATTERN, METAL MASK AND FFC/FPC							DIMENSION OF DRAWING FOR PACKING					
			A	B	C	D	E	F	G	H	J	K	L	M	N
		4	6.3	1.5	2.57	4.7	4.1	4.1	2.5	6.6	7.5	16.0	—	21.4	17.4
△		5	6.8	2.0	3.07	5.2	4.6	4.6	3.0	7.1	11.5	24.0	—	29.4	25.4
△	CL580-3304-0-00	6	7.3	2.5	3.57	5.7	5.1	5.1	3.5	7.6	11.5	24.0	—	29.4	25.4
	CL580-3305-3-00	8	8.3	3.5	4.57	6.7	6.1	6.1	4.5	8.6	11.5	24.0	—	29.4	25.4
	CL580-3306-6-00	10	9.3	4.5	5.57	7.7	7.1	7.1	5.5	9.6	11.5	24.0	—	29.4	25.4
	CL580-3320-7-00	11	9.8	5.0	6.07	8.2	7.6	7.6	6.0	10.1	11.5	24.0	—	29.4	25.4
	CL580-3307-9-00	12	10.3	5.5	6.57	8.7	8.1	8.1	6.5	10.6	11.5	24.0	—	29.4	25.4
	CL580-3302-5-00	15	11.8	7.0	8.07	10.2	9.6	9.6	8.0	12.1	11.5	24.0	—	29.4	25.4
		16	12.3	7.5	8.57	10.7	10.1	10.1	8.5	12.6	11.5	24.0	—	29.4	25.4
	CL580-3321-0-00	18	13.3	8.5	9.57	11.7	11.1	11.1	9.5	13.6	11.5	24.0	—	29.4	25.4
	CL580-3309-4-00	20	14.3	9.5	10.57	12.7	12.1	12.1	10.5	14.6	11.5	24.0	—	29.4	25.4
△	CL580-3317-2-00	22	15.3	10.5	11.57	13.7	13.1	13.1	11.5	15.6	14.2	32.0	28.4	37.4	33.4
	CL580-3318-5-00	24	16.3	11.5	12.57	14.7	14.1	14.1	12.5	16.6	14.2	32.0	28.4	37.4	33.4
△	CL580-3316-0-00	25	16.8	12.0	13.07	15.2	14.6	14.6	13.0	17.1	14.2	32.0	28.4	37.4	33.4
△	CL580-3319-8-00	26	17.3	12.5	13.57	15.7	15.1	15.1	13.5	17.6	14.2	32.0	28.4	37.4	33.4
	CL580-3324-8-00	28	18.3	13.5	14.57	16.7	16.1	16.1	14.5	18.6	14.2	32.0	28.4	37.4	33.4
	CL580-3310-3-00	30	19.3	14.5	15.57	17.7	17.1	17.1	15.5	19.6	14.2	32.0	28.4	37.4	33.4
	CL580-3325-0-00	32	20.3	15.5	16.57	18.7	18.1	18.1	16.5	20.6	20.2	44.0	40.4	49.4	45.4
	CL580-3300-0-00	40	24.3	19.5	20.57	22.7	22.1	22.1	20.5	24.6	20.2	44.0	40.4	49.4	45.4
	CL580-3329-1-00	42	25.3	20.5	21.57	23.7	23.1	23.1	21.5	25.6	20.2	44.0	40.4	49.4	45.4
	CL580-3311-6-00	45	26.8	22.0	23.07	25.2	24.6	24.6	23.0	27.1	20.2	44.0	40.4	49.4	45.4
	CL580-3303-8-00	50	29.3	24.5	25.57	27.7	27.1	27.1	25.5	29.6	20.2	44.0	40.4	49.4	45.4
	CL580-3301-2-00	60	34.3	29.5	30.57	32.7	32.1	32.1	30.5	34.6	26.2	56.0	52.4	61.4	57.4

※CONTACT POSITIONS WITHOUT CODE NUMBERS ARE CURRENTLY UNDER PLANNING.  
PLEASE CONTACT HIROSE FOR DETAILED INFORMATION ABOUT PRODUCT VARIATION.

<b>HRS</b>	DRAWING NO.	EDC3-328248-00
	PART NO.	FH52-***S-0.5SH
	CODE NO.	CL580
		△ 4/6

This connector requires delicate and careful handling.  
 Read through the instructions shown below and handle the connector properly.  
 Each values indicating here are for reference and may differ from standard value.

[INSTRUCTIONS FOR MOUNTING ON THE BOARD]

◆ Warp of Board

Minimize warp of the board as much as possible.  
 Lead co-planarity including reinforced metal fittings is 0.1 mm or less.  
 Too much warp of the board may result in a soldering failure.

◆ Load to Connector

Do not apply a force of 1 N or more to the connector before mounting it on the board.  
 Otherwise, the connector may be broken.  
 Do not insert the FFC/FPC or operate the connector before mounting it.

◆ Load to Board

- Splitting a large board into several pieces
  - Screwing the board
- Avoid the handling described above so that no force is exerted on the board during the assembly process.  
 Otherwise, the connector may become defective.

◆ Amount of Warp

The warp of a 100mm wide board should be 1 mm or less.  
 The warp of board suffers stress on connector and the connector may become defective.

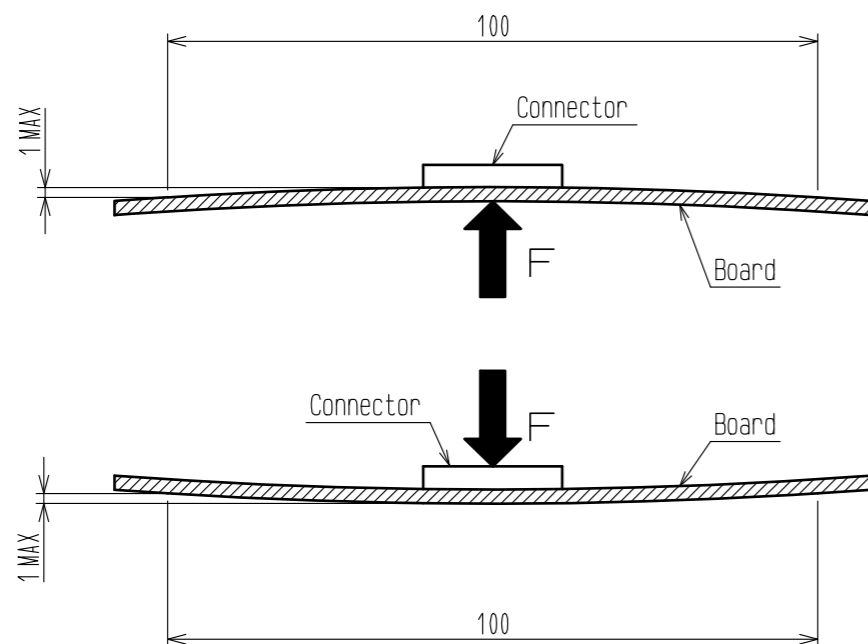

[INSTRUCTIONS ON INSERTING FFC/FPC AND CONNECTION]

◆ Use of the Actuator

1. Be very careful not to apply excessive force when releasing the actuator in the initial position.  
 If you use your nail or finger as shown below, the terminals may be deformed.

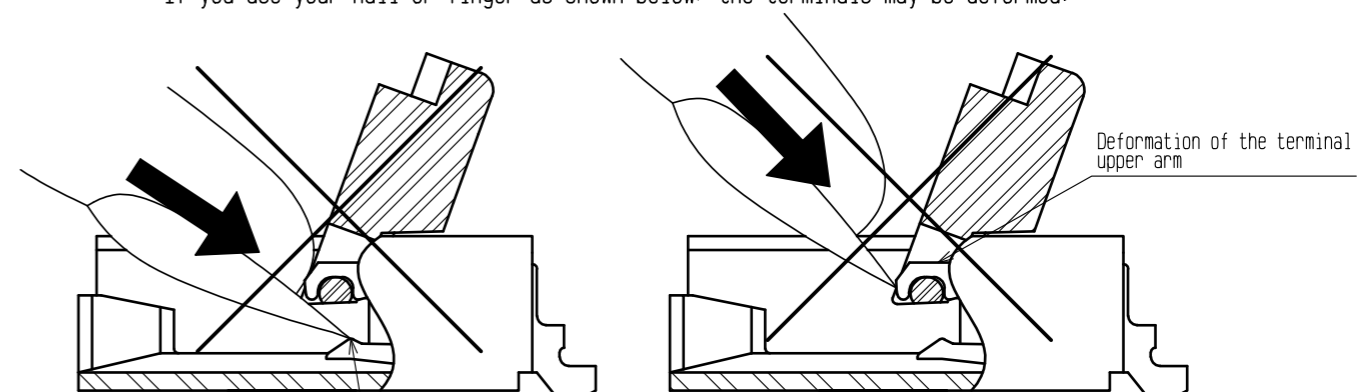

Deformation of the terminal

2. The actuator rotates around the rotational axis as shown below.  
 Rotate the actuator.
3. The actuator will not open more than 110°.  
 Do not apply any force backward beyond this point.  
 Otherwise, the actuator may come off or break.

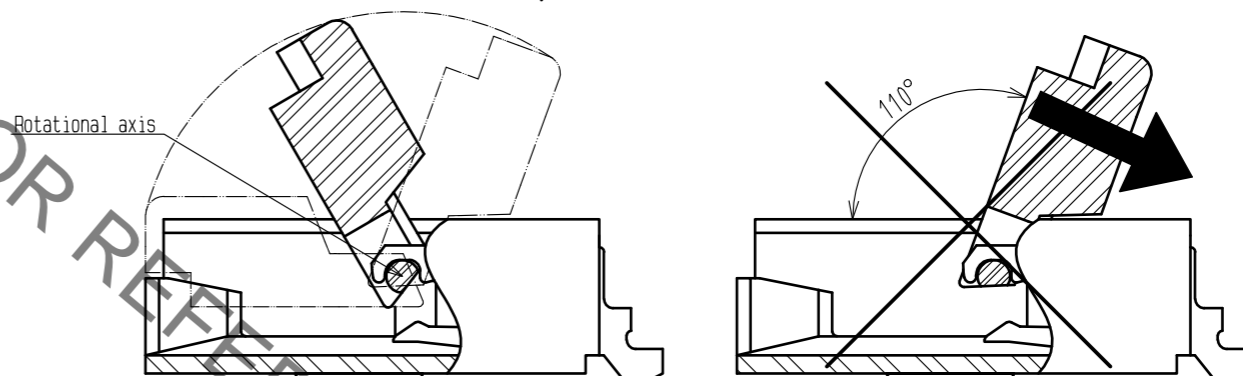

4. Move the actuator at approximately the center.
5. Do not pinch or pick the actuator to lift it as shown below. Otherwise, it may break.  
 (Do not carry out any operation other than rotating the actuator as shown in 2 above.)

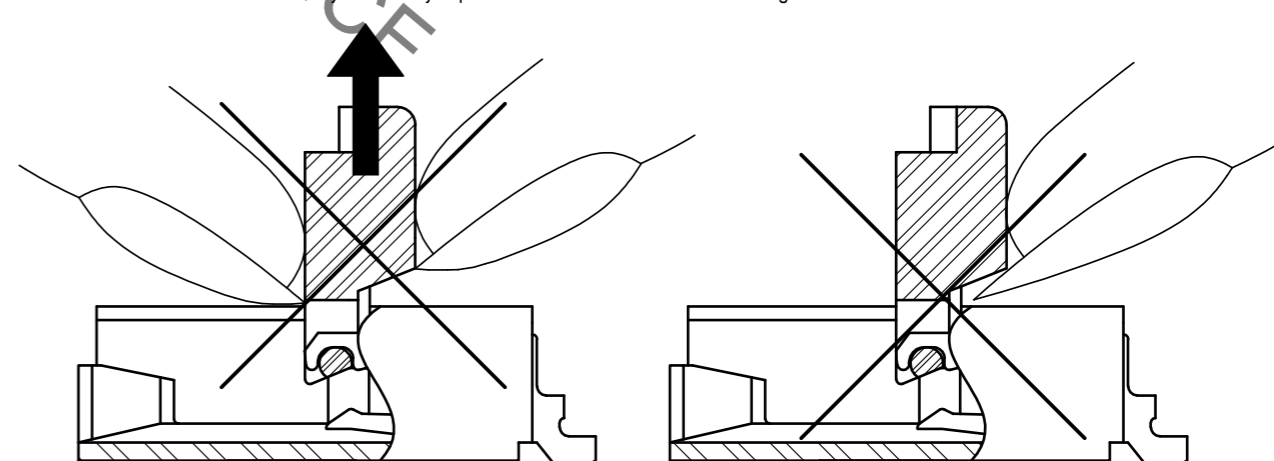

< INSTRUCTION MANUAL(1) >

<b>HRS</b>	DRAWING NO.	EDC3-328248-00
	PART NO.	FH52-***S-0.5SH
	CODE NO.	CL580
		5/6

Sep.1.2021 Copyright 2021 HIROSE ELECTRIC CO., LTD. All Rights Reserved.  
In case of consideration for using Automotive equipment / device which demand high reliability, kindly contact our sales window correspondents.

◆ Direction of Contacts

This connector has contacts on the bottom. Thus, insert FFC/FPC with the exposed conductors face down.

◆ Inserting the FFC/FPC

1. Insert the FFC/FPC by about 10 degrees along the surface and at a right angle to the connector.  
Insert it properly to the very end.

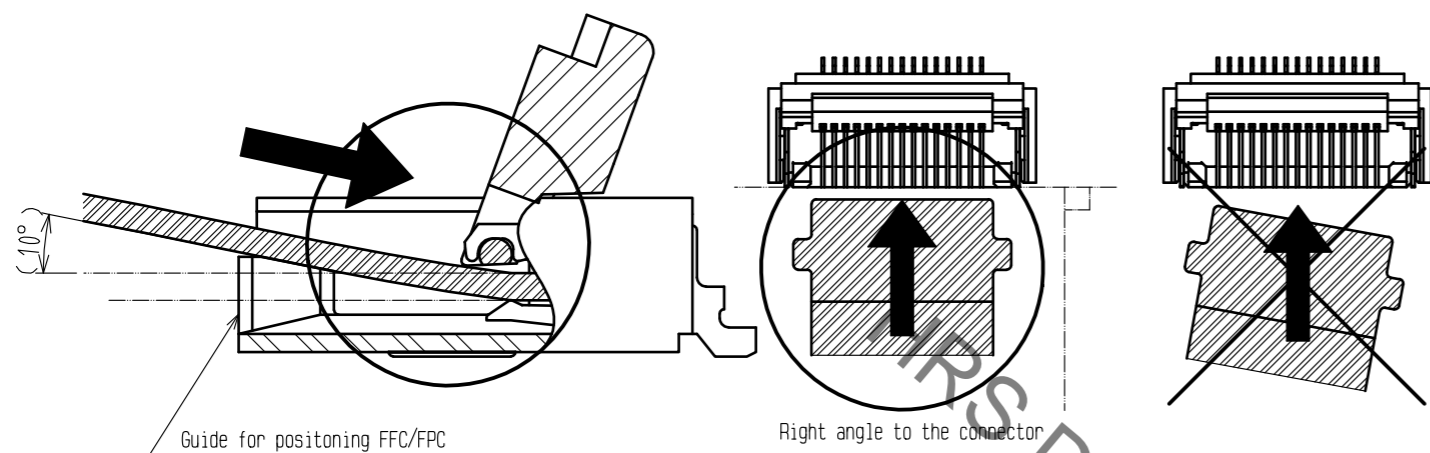

2. Do not insert the FFC/FPC diagonally from above.  
If the FFC/FPC is inserted at a slant (incorrectly) as shown below in the FFC/FPC insertion process, the edge of the FFC/FPC may catch in the terminals, resulting in deformation of the terminals. The FFC/FPC may bend and patterns may break or the FFC may not insert completely, resulting in improper conduction.

- ※ Keep a sufficient FFC/FPC insertion space in the stage of the layout in order to avoid incorrect FFC/FPC insertion.  
Besides, it is not difficult to insert FFC/FPC correctly all the way to the end. Design the proper layout of parts.

- ※ Make adjustments with the FFC/FPC manufacturer for FFC/FPC bending performance and wire breakage.

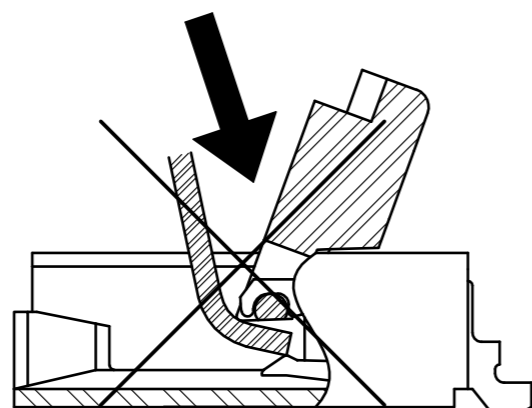

3. Do not rotate the actuator when FFC/FPC TAB is on right and left guides for positioning FFC/FPC.  
Make sure the position of FFC TAB and guides before rotate the actuator.

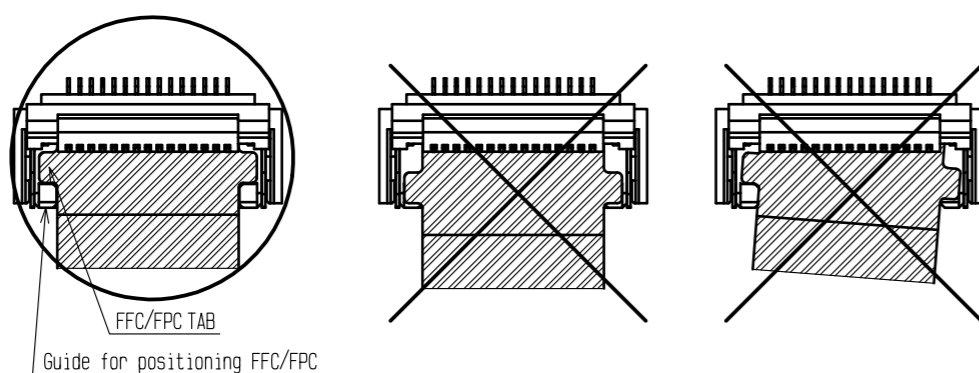

◆ Checking the Locking Condition

In the locked condition, make sure that the actuator is horizontal on the board surface.  
Do not apply excessive force to it near the 0° position of the actuator.  
Otherwise, the terminals may be deformed.

[INSTRUCTIONS ON FFC/FPC LAYOUT AFTER CONNECTION]

◆ Load to FFC/FPC

Be very careful not to apply any force to the connector directly after inserting FFC/FPC.  
Otherwise, the connector may become unlocked or the FFC/FPC may break.  
In particular, design the FFC/FPC layout with care not to bend it sharply upward in a vertical direction near the insertion opening.  
Fix the FFC/FPC when loads are applied to it continuously.

$$\text{Load: } 0.10 \times n \text{ N MAX}$$

(n: number of contacts)

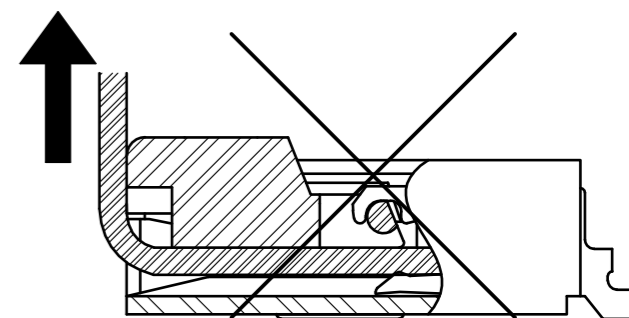

[INSTRUCTIONS ON REMOVING FFC/FPC]

- ◆ Move the actuator at approximately the center.
- ◆ Release the actuator to remove the FFC/FPC.  
Remove the FFC/FPC by about 10 degrees along the surface.

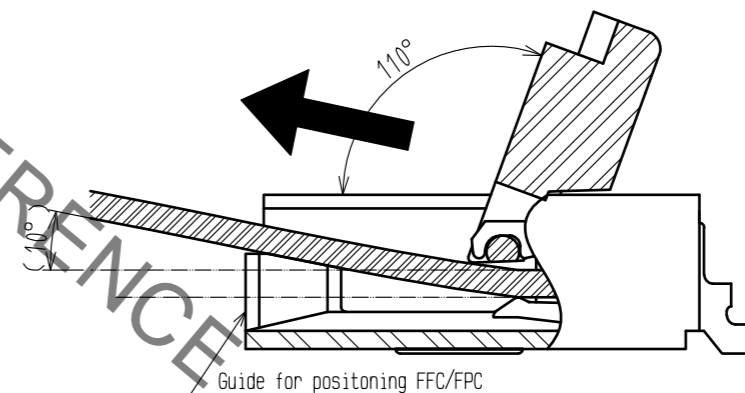

[OTHER INSTRUCTIONS]

◆ Instructions on Manual Soldering

- Follow the instructions shown below when soldering the connector manually during repair work, etc.
1. Do not perform reflow soldering or manual soldering with the FFC inserted into the connector.
  2. Do not heat the connector excessively. Be very careful not to let the soldering iron contact any parts other than connector leads. Otherwise, the connector may be deformed or melt.
  3. Do not use excessive solder (or flux).  
If excessive solder (or flux) is used on the terminals, solder or flux may adhere to the contacts or rotating parts of the actuator, resulting in poor contact or a rotation failure of the actuator. Supplying excessive solder to the reinforcing bracket may hinder actuator rotation, resulting in breakage of the connector.

< INSTRUCTION MANUAL (2) >

<b>HRS</b>	DRAWING NO.	EDC3-328248-00
	PART NO.	FH52-***S-0.5SH
	CODE NO.	CL580