

## FG-R01-4A

Aliases (USETR014AA0000)

KEMET, FG-R01-4A, Current, Through-Hole, Residual, Open-loop, Fluxgate-Based Current Detection, PCB Mounting

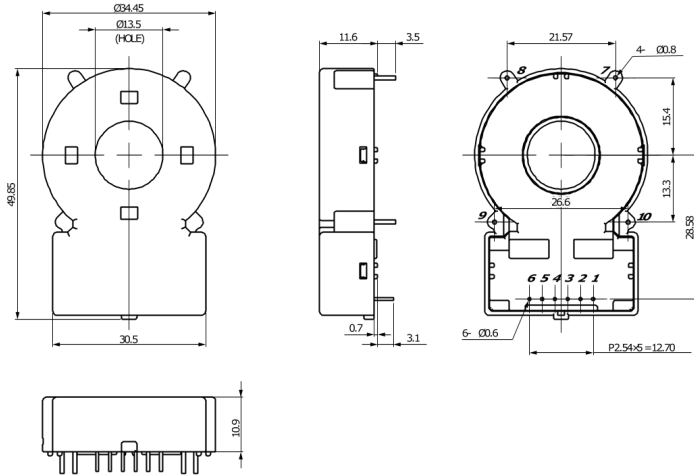

Click [here](#) for the 3D model.

### Dimensions

D	34.45mm NOM
L	30.5mm MAX
W	49.85mm MAX
T	10.9mm MAX
LL	3.5mm MAX

### Packaging Specifications

Packaging	Tray, Box
Packaging Quantity	300
Typical Component Weight	20 g

### General Information

Series	FG-R01-4A
Type	Current
Style	Through-Hole
Description	Fluxgate-Based Residual Current Sensor
Features	Open-loop, Fluxgate-Based Current Detection, PCB Mounting
Lead	6 Pin
RoHS	Yes
REACH	Yes
SCIP Number	1c8d8664-44b6-4879-9276-8538e42f2c42
Qualifications	IEC

### Specifications

Temperature Range	-40/+105°C
Voltage DC	2.25 V (PIN3, Analog Output; typical)
Power Supply Voltage	5 V +/- 5%
Current	6 mA (MAX; DC Detection), 20 mArms (MAX, 55 Hz; AC Detection)
Sensitivity	40 V/A (PIN3, AOUT; typical)
Frequency Range	150 Hz MAX (at -3 dB; PIN3 AOUT)
Measuring Range	+/-50 mA
AC Alarm Response Time	60 typical, 250 maximum (ms, @30 mArms); 20 typical, 100 maximum (ms, @60 mArms); 8 typical, 20 maximum (ms, @150 mArms); 7 typical, 10 maximum (ms, @264 mArms); 7 typical, 10 maximum (ms, > 5 Arms)
DC Alarm Response Time	280 typical, 1000 maximum (ms, @6 mA); 24 typical, 250 maximum (ms, @60 mA); 6 typical, 15 maximum (ms, @300 mA)