

FCS-M18-AP8X

Flow Monitoring – Immersion Sensor with Integrated Processor

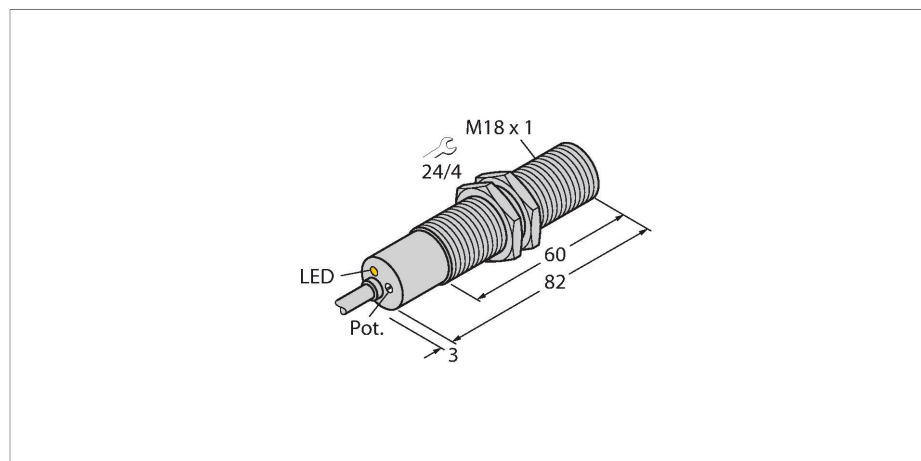

Features

- Flow sensor for gaseous media
- Calorimetric principle
- Adjustment via potentiometer
- Status display via 2-color LED
- Chrome-plated brass sensor
- 3-wire DC, 19.2...28.8 VDC
- NO contact, PNP output
- Cable device

Wiring diagram

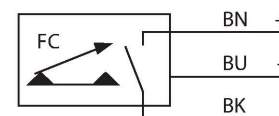

Technical data

ID	6870704
Type	FCS-M18-AP8X
Mounting	Immersion sensor
Air Operating Range	0.5...15 m/s
Switch-on time	typ. 2 s (1...20 s)
Switch-off time	typ. 2 s (1...20 s)
Temperature gradient	≤ 200 K/min
Medium temperature	-20...+70 °C
Ambient temperature	0...+60 °C
Electrical data	
Operating voltage	19.2...28.8 VDC
Current consumption	≤ 70 mA
Output function	PNP, NO contact
Rated operational current	0.4 A
Short-circuit protection	yes
Reverse polarity protection	yes
Protection class	IP67
MTTF	637 years acc. to SN 29500 (Ed. 99) 40 °C
Mechanical data	
Design	Immersion
Housing material	Metal, CuZn
Sensor material	Brass, brass, nickel-plated
Electrical connection	Cable

Functional principle

The function of immersion flow sensors is based on the thermodynamic principle. The sensor is heated up by a few degrees Celsius compared to the flow medium. If the medium flows past the sensor, the heat generated in the sensor is dissipated. The resulting temperature is measured and compared with the temperature of the medium. The flow condition of each medium can be derived from the temperature difference obtained. Thus, TURCK flow sensors reliably and wear-free monitor the flow of liquid or gaseous media.

Technical data

Cable length (L)	2 m
Core cross-section	3 x 0.5 mm ²
Process connection	M18 x 1
Switching state	2-color LED, Red/Green
Tests/approvals	
Approvals	cULus
UL registration number	E210608