

# Synchronous Regulator, TINYBOOST<sup>®</sup>, 2.5 MHz

## FAN48695

### Description

The FAN48695 is a low-power boost regulator designed to provide a regulated output voltage from a single cell Lithium or Li-Ion battery. The device maintains output voltage regulation within the recommended operating conditions. The combination of built-in power transistors, synchronous rectification and low supply current make the FAN48695 ideal for battery-powered applications.

The FAN48695 is available in a 9-bump, 0.4 mm pitch, Wafer-Level Chip Scale Package (WLCSP).

### Features

- Input Voltage Range: 2.5 V to 5.5 V
- 1 A Load Capability
- PFM / PWM for high efficiency
- 2.5 MHz Fixed Frequency PWM Operation
- Synchronous Rectification
- Reverse Current Blocking
- Automatic Pass-Through Operation
- Forced Pass-Through Mode
- Over Temperature Protection
- Over Current Protection
- Under Voltage Protection
- 3 Stage Soft Start
- These Devices are Pb-Free and are RoHS Compliant

### Applications

- NFC/USB/Power Amp
- Cell Phones, Smart Phones, Portable Instruments

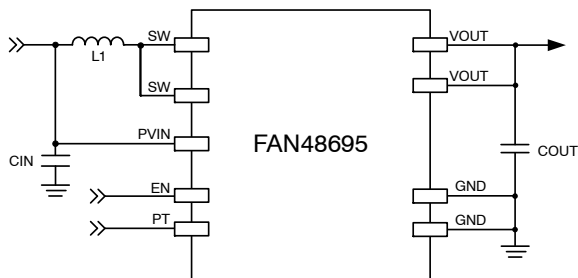

Figure 1. Typical Application

Table 1. ORDERING INFORMATION

| Part Number    | V <sub>OUT</sub> * | Operating Temperature Range | Package                             | Packing†           | Device Marking |
|----------------|--------------------|-----------------------------|-------------------------------------|--------------------|----------------|
| FAN48695UC190X | 5.0 V              | -40°C to 85°C               | 9-Bump, 0.4 mm Pitch, WLCSP Package | 3000 / Tape & Reel | 2G             |

†For information on tape and reel specifications, including part orientation and tape sizes, please refer to our Tape and Reel Packaging Specification Brochure, BRD8011/D.

\*Additional Output voltage options are available upon request.



ON Semiconductor<sup>®</sup>

[www.onsemi.com](http://www.onsemi.com)



WLCSP9  
CASE 567VH

### MARKING DIAGRAM

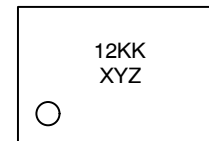

- 12 = Alphanumeric Device Code  
(See Ordering Information for specific device marking)
- KK = Lot Run Number
- X = Alphabetical Year Code
- Y = 2-weeks Date Code
- Z = Assembly Plant Code



Pin Configuration

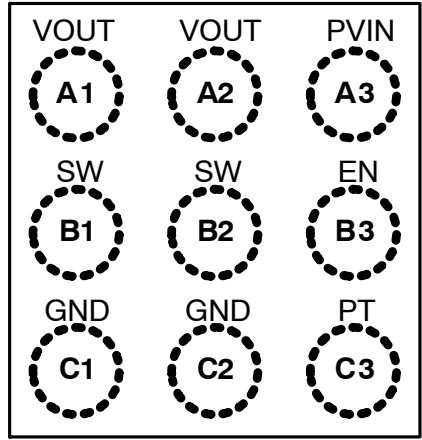

Top View

Figure 3. WLCSP

Table 3. PIN DEFINITIONS

| Pin | Name | Description   |
|-----|------|---|
| A1  | VOUT | Output Voltage: Output of Boost Regulator. Connect $C_{OUT}$ to this pin using the lowest impedance trace possible.                                     |
| A2  |      |   |
| A3  | PVIN | Input Voltage: Input power source for Boost Regulator. Connect $C_{IN}$ directly to this pin using the lowest impedance trace possible.                 |
| B1  | SW   | Switching Node: Connect L1 to this pin.   |
| B2  |      |   |
| B3  | EN   | Enable: A logic HIGH enables the device. A logic LOW disables the device.   |
| C1  | GND  | Ground: Power and signal ground reference for the IC. $C_{IN}$ and $C_{OUT}$ should be connected to this pin using the lowest impedance trace possible. |
| C2  |      |   |
| C3  | PT   | Pass-Through: A logic HIGH will place the device in Forced Pass-Through mode.   |

**Table 4. MAXIMUM RATINGS**

| Symbol            | Parameter                                | Conditions           | Min  | Max      | Units |
|-------------------|--|----------------------|------|----------|-------|
| V <sub>IN</sub>   | Input Voltage                            | PVIN pin             | -0.3 | 6.0      | V     |
| V <sub>OUT</sub>  | Output Voltage                           | VOUT pin             | -0.3 | 6.0      | V     |
| V <sub>SW</sub>   | Continuous Switch Node Voltage           | SW pin               | -0.3 | 6.5      | V     |
| V <sub>CTRL</sub> | Control Voltage                          | EN and PT pins       | -0.3 | (Note 1) | V     |
| ESD               | Electrostatic Discharge Protection Level | Human Body Model     | 2.0  |          | kV    |
|                   |  | Charged Device Model | 1.0  |          | kV    |
| T <sub>J</sub>    | Junction Temperature                     |                      | -40  | +150     | °C    |
| T <sub>STG</sub>  | Storage Temperature                      |                      | -65  | +150     | °C    |
| T <sub>L</sub>    | Soldering Temperature (10 Seconds)       |                      |      | +260     | °C    |

Stresses exceeding those listed in the Maximum Ratings table may damage the device. If any of these limits are exceeded, device functionality should not be assumed, damage may occur and reliability may be affected.

1. Lesser of 6 V or V<sub>IN</sub> + 0.3 V.

**Table 5. RECOMMENDED OPERATING CONDITIONS**

| Symbol           | Parameter                     | Conditions               | Min  | Typ | Max  | Units |
|------------------|-------------------------------|--------------------------|------|-----|------|-------|
| V <sub>IN</sub>  | Supply Voltage Range          | PV <sub>IN</sub>         | 2.5  |     | 5.5  | V     |
| L                | Inductor                      |                          |      | 1.0 |      | μH    |
| C <sub>IN</sub>  | Input Capacitance             |                          |      | 10  |      | μF    |
| C <sub>OUT</sub> | Output Capacitance (Note 2)   |                          | 3.5  | 22  |      | μF    |
| I <sub>OUT</sub> | Output Current (Note 3)       | PV <sub>IN</sub> ≥ 2.8 V | 1000 |     |      | mA    |
| T <sub>A</sub>   | Operating Ambient Temperature |                          | -40  |     | +85  | °C    |
| T <sub>J</sub>   | Junction Temperature          |                          | -40  |     | +125 | °C    |

Functional operation above the stresses listed in the Recommended Operating Ranges is not implied. Extended exposure to stresses beyond the Recommended Operating Ranges limits may affect device reliability.

- The effective capacitance (CEFF) of small, high-value, ceramic capacitors will decrease as bias voltage increases. The effects of bias voltage (DC bias characteristics), tolerance, and temperature must be considered.
- Refer to Figure 17 in Application Information Section.

**Table 6. THERMAL PROPERTIES**

| Symbol          | Parameter                              | Typical | Unit |
|-----------------|--|---------|------|
| θ <sub>JA</sub> | Junction-to-Ambient Thermal Resistance | 50      | °C/W |

NOTE: Junction-to-ambient thermal resistance is a function of application and board layout. This data is measured with two-layer 2s2p boards in accordance to JEDEC standard JESD51. Special attention must be paid not to exceed junction temperature T<sub>J(max)</sub> at a given ambient temperature T<sub>A</sub>.

# FAN48695

**Table 7. ELECTRICAL SPECIFICATIONS** (Note 4)

Minimum and maximum values are at  $PV_{IN} = 2.5$  to  $5.5$  V and  $PV_{IN} < V_{OUT} - 300$  mV,  $EN = 1.8$  V,  $PT = 0$  V,  $T_A = -40^\circ\text{C}$  to  $+85^\circ\text{C}$  unless otherwise specified. Typical values are at  $T_A = 25^\circ\text{C}$ ,  $PV_{IN} = 3.8$  V,  $EN = 1.8$  V,  $PT = 0$  V.

| Symbol | Parameter | Conditions | Min | Typ | Max | Units |
|--------|-----------|------------|-----|-----|-----|-------|
|--------|-----------|------------|-----|-----|-----|-------|

## POWER SUPPLIES

|               |  |  |      |      |      |               |
|---------------|--|--|------|------|------|---------------|
| $I_{Q\_PFM}$  | Quiescent Current                          | No Load, Non Switching,<br>$PV_{IN} \leq V_{OUT} - 300$ mV |      | 27   | 40   | $\mu\text{A}$ |
| $I_{Q\_APT}$  | Auto Pass-Through Operating IQ             | No Load, $PV_{IN} = 5.5$ V                                 |      | 40   | 60   | $\mu\text{A}$ |
| $I_{Q\_FPT}$  | Forced Pass-Through Mode Operating Current | No Load, $PV_{IN} = 3.8$ V, $PT = 1.8$ V                   |      | 9    | 15   | $\mu\text{A}$ |
| $I_{SD}$      | Shutdown Current                           | $EN = 0$ V   |      | 3    | 8    | $\mu\text{A}$ |
| $V_{UVLO\_R}$ | Under-Voltage Lockout Threshold            | Rising $PV_{IN}$   | 2.10 | 2.15 | 2.20 | V             |
| $V_{UVLO\_F}$ | Under-Voltage Lockout Threshold            | Falling $PV_{IN}$  | 2.00 | 2.05 | 2.10 | V             |

## OUTPUT VOLTAGE ACCURACY

|              |                          |   |       |       |       |   |
|--------------|--------------------------|---|-------|-------|-------|---|
| $V_{O\_ACC}$ | Regulated Output Voltage | $PV_{IN} = 3.8$ V, No Load (PFM Mode)             | 4.884 | 5.035 | 5.186 | V |
|              |                          | $PV_{IN} = 3.8$ V, $I_{LOAD} = 200$ mA (PWM Mode) | 4.900 | 5.000 | 5.100 | V |

## REGULATOR

|                  |   |                    |      |      |      |                  |
|------------------|---|--------------------|------|------|------|------------------|
| $F_{SW}$         | PWM Switching Frequency                           | $PV_{IN} = 3.8$ V  | 2.25 | 2.50 | 2.75 | MHz              |
| $R_{DS_{ON\_P}}$ | PMOS Resistance, SW to VOUT                       |                    |      | 55   | 100  | $\text{m}\Omega$ |
| $R_{DS_{ON\_N}}$ | NMOS Resistance, SW to PGND                       |                    |      | 55   | 100  | $\text{m}\Omega$ |
| $I_{SW\_LIM}$    | Inductor Peak Current Limit                       |                    | 2.34 | 2.63 | 2.84 | A                |
| LIN1             | First Stage Linear Soft Start Input Current Limit | $V_{OUT} = 2.0$ V  |      | 280  |      | mA               |
| LIN2             | Linear Soft Start Input Current Limit             | $V_{OUT} = 2.0$ V  |      | 600  |      | mA               |
| $T_{SD}$         | Thermal Shutdown Threshold                        | $I_{LOAD} = 10$ mA |      | 145  |      | $^\circ\text{C}$ |
| $T_{HYS}$        | Thermal Shutdown Hysteresis                       |                    |      | 28   |      | $^\circ\text{C}$ |

## LOGIC PINS (EN, PT)

|          |                      |                      |     |     |     |                  |
|----------|----------------------|----------------------|-----|-----|-----|------------------|
| $V_{IL}$ | Logic Low threshold  |                      |     |     | 0.4 | V                |
| $V_{IH}$ | Logic High threshold |                      | 1.2 |     |     | V                |
| $R_{PD}$ | Pull-Down Resistance | Logic Low state only |     | 300 |     | $\text{k}\Omega$ |

Product parametric performance is indicated in the Electrical Characteristics for the listed test conditions, unless otherwise noted. Product performance may not be indicated by the Electrical Characteristics if operated under different conditions.

4. Specifications in the Electrical Characteristics table reflect open-loop, steady-state data.

TYPICAL CHARACTERISTICS

Unless otherwise specified, circuit of Figure 1 using recommended external components and layout,  $T_A = 25^\circ\text{C}$ ,  $PV_{IN} = 3.8\text{ V}$ ,  $EN = 1.8\text{ V}$ .

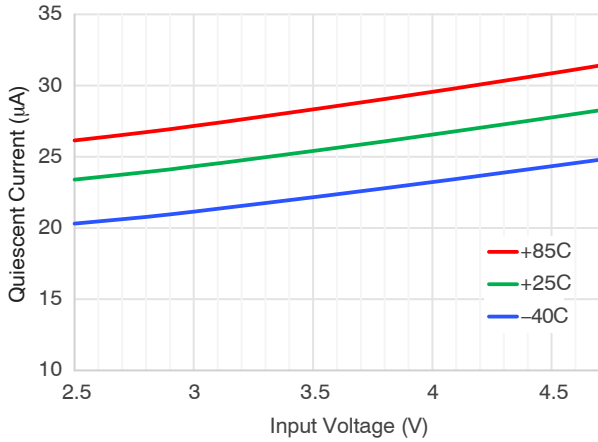

Figure 4. Quiescent Current (Non-Switching) vs. Input Voltage

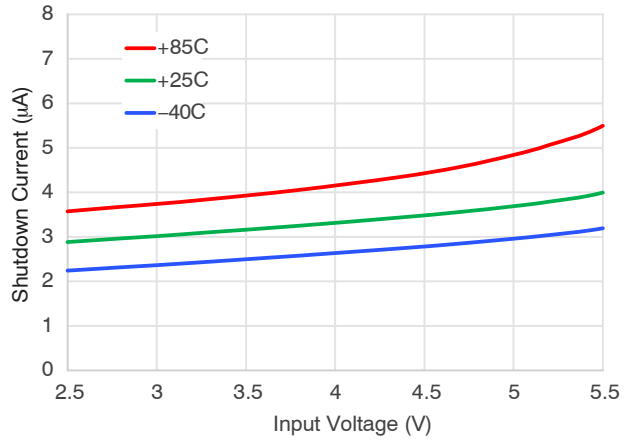

Figure 5. Shutdown Current vs. Input Voltage

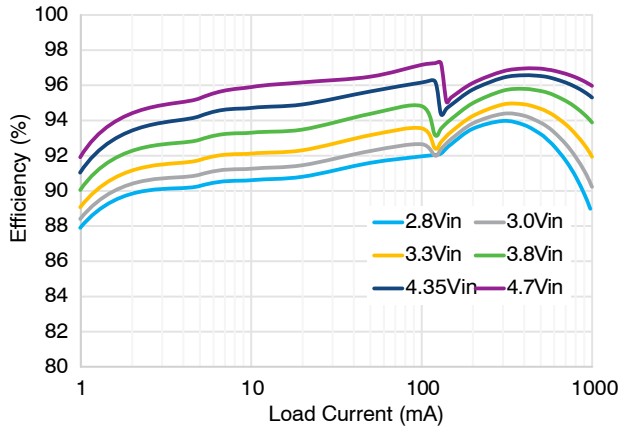

Figure 6. Efficiency vs. Load Current and Input Voltage, L = DFE201610E-1R0M

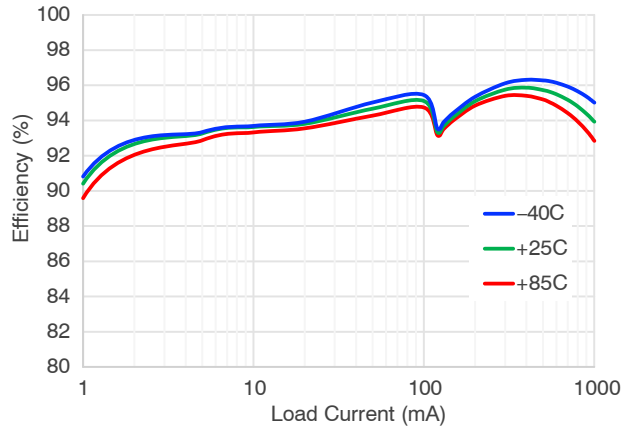

Figure 7. Efficiency vs. Load Current and Temperature, L = DFE201610E-1R0M

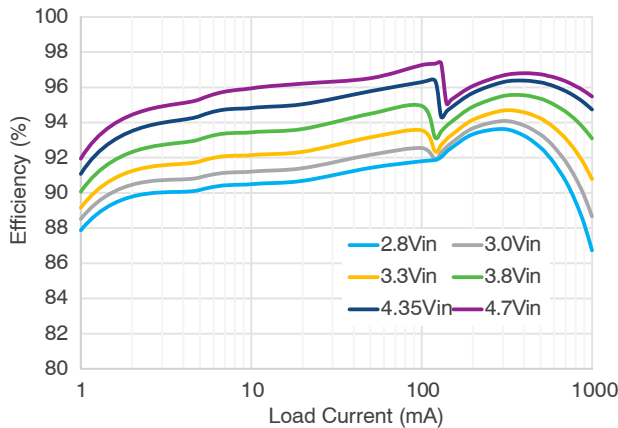

Figure 8. Efficiency vs. Load Current and Input Voltage, L = DFE201610R-H-1R0M

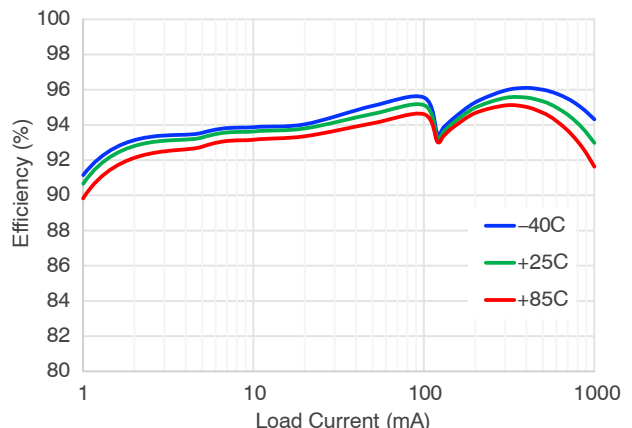

Figure 9. Efficiency vs. Load Current and Temperature, L = DFE201610R-H-1R0M

TYPICAL CHARACTERISTICS

Unless otherwise specified, circuit of Figure 1 using recommended external components and layout,  $T_A = 25^\circ\text{C}$ ,  $PV_{IN} = 3.8\text{ V}$ ,  $EN = 1.8\text{ V}$ .

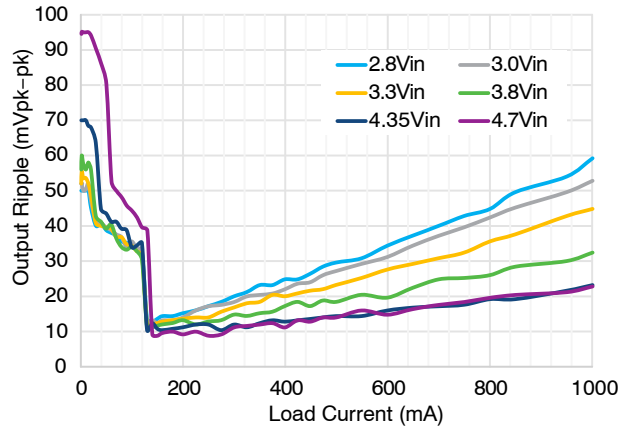

Figure 10. Output Ripple vs. Load Current

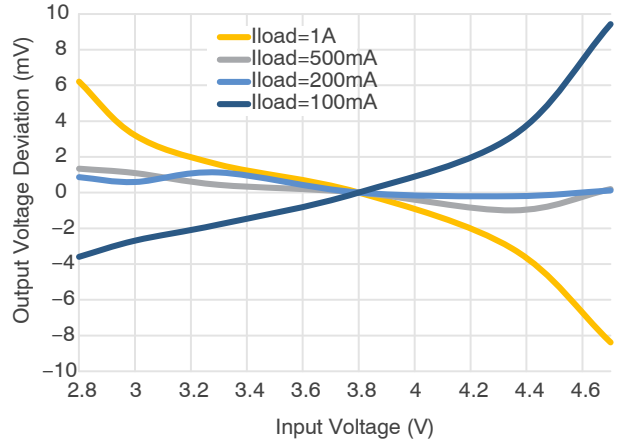

Figure 11. Line Regulation, Deviation from 3.8  $PV_{IN}$  Measurement

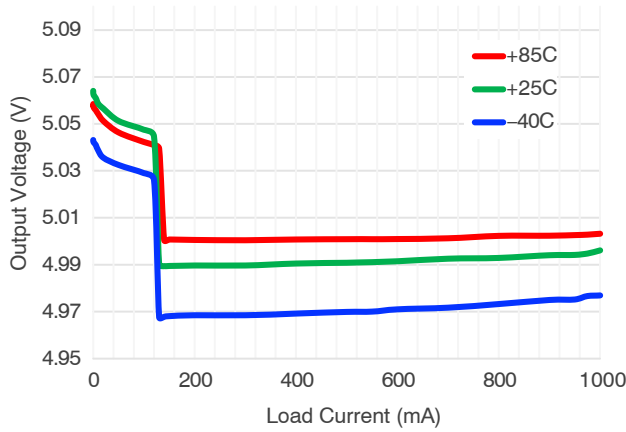

Figure 12. Load Regulation

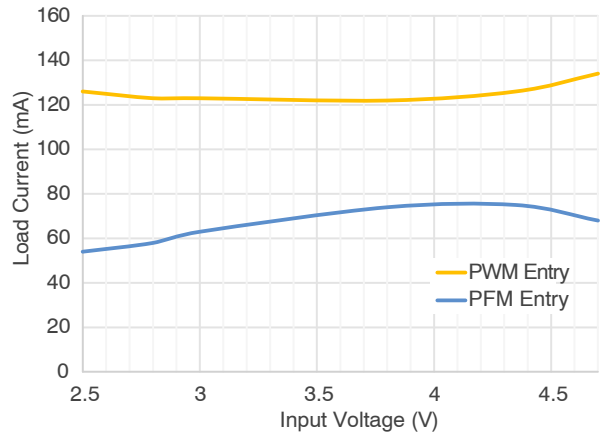

Figure 13. PWM/PFM Entry Thresholds vs. Input Voltage

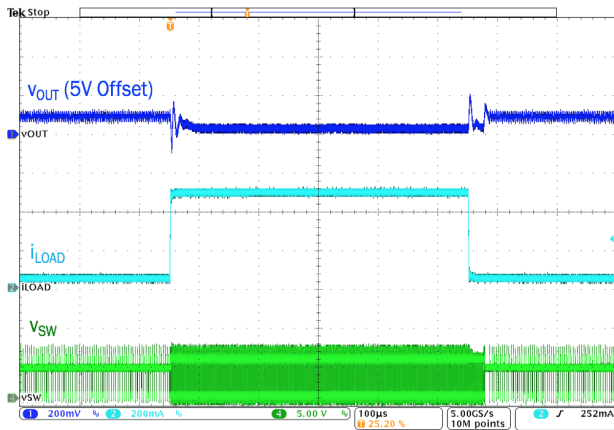

Figure 14. Load Transient, 50 mA ↔ 500 mA, 1  $\mu\text{s}$  Edge

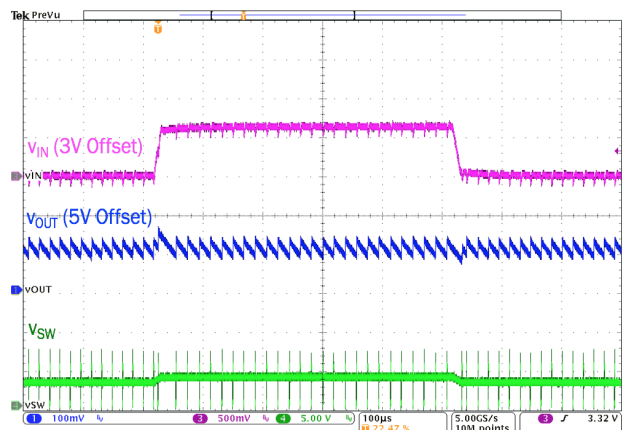

Figure 15. Line Transient, 3.0 V ↔ 3.6 V, 10  $\mu\text{s}$  Edge, 10 mA Load

# FAN48695

## TYPICAL CHARACTERISTICS

Unless otherwise specified, circuit of Figure 1 using recommended external components and layout,  $T_A = 25^\circ\text{C}$ ,  $PV_{IN} = 3.8\text{ V}$ ,  $EN = 1.8\text{ V}$ .

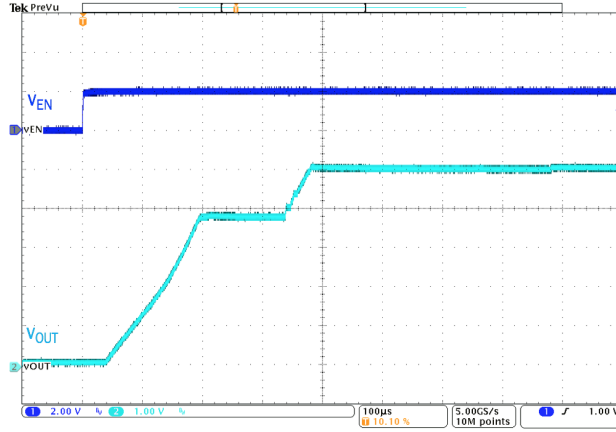

Figure 16. Start-Up into 50  $\Omega$  Load

APPLICATION INFORMATION

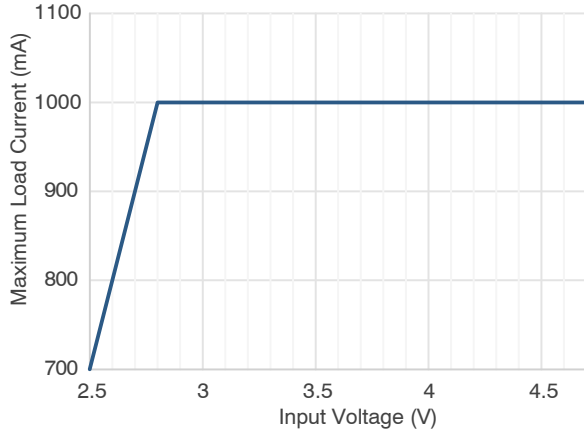

Figure 17. Load Capability vs. Input Voltage

Operation Description

The FAN48695 is a low-power boost regulator designed to provide a regulated output voltage from a single cell Lithium or Li-Ion battery. It maintains the output in regulation within the devices recommended operating conditions. For higher efficiency at low load conditions, the device will transition into PFM Mode.

Automatic Pass-Through Mode will occur during boost Mode if the input voltage rises close to or above the desired output voltage. Additionally, the device can be put into Forced Pass-Through Mode when boosting the output is not required by setting the PT pin to HIGH.

Startup Description

The FAN48695 can startup in either Boost Mode or Forced Pass-Through (FPT) Mode. Both modes use a two

stage linear soft-start to limit inrush currents from the source.

Linear Soft-Start State

An internal fixed current source of LIN1 is applied to  $V_{OUT}$  for up to 500  $\mu s$ . If  $V_{OUT}$  does not reach  $V_{IN} - 300 mV$  within 500  $\mu s$ , the current source is increased to LIN2 for up to an additional 1 ms.

Boost Mode:

- If any time during the Linear Soft-Start State  $V_{OUT}$  charges up to  $V_{IN} - 300 mV$ , the fixed current source will be disabled and the device then proceeds to the Switching Soft-Start State.
- If  $V_{OUT}$  fails to charge up to  $V_{IN} - 300 mV$  by the end of LIN2, the fixed current source is disabled, a fault condition is declared, and the device waits 20 ms to attempt an automatic restart.

FPT Mode:

- If  $V_{OUT}$  charges up to  $V_{IN}$ , Forced Pass-Through Mode is achieved.
- If  $V_{OUT}$  fails to charge up to  $V_{IN}$  by the end of LIN2, the fixed current source is disabled, a fault condition is declared, and the device waits 20 ms to attempt an automatic restart.

Switching Soft-Start State

The regulator begins switching in PFM operation with  $I_{SW\_LIM}$  set to one-quarter its normal value until  $V_{OUT}$  reaches its target voltage or 100  $\mu s$  has elapsed. The device will then transition to BOOST Mode with  $I_{SW\_LIM}$  returned to its typical value.

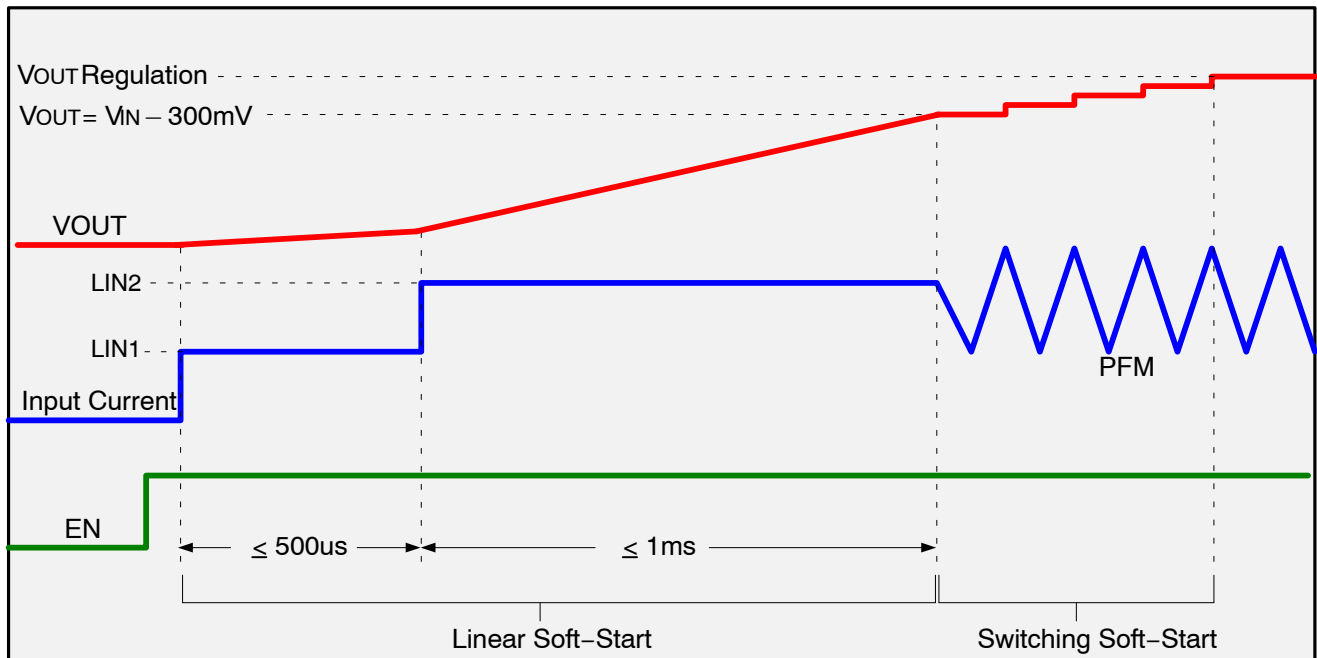

Figure 18. Boost Mode Startup

**Shutdown Description**

The boost can be disabled by asserting the EN pin low. The output (VOUT) will discharge into the prevailing load.

**Modes of Operation**

*Boost PWM Mode*

During PWM mode, the boost regulates the output using a fixed switching frequency of ~2.5 MHz. As the load increases, the inductor current will have an increasing DC offset. The period of when the V<sub>SW</sub> (voltage at switching

node) signal is low, will grow as the battery voltage in a mobile device decays.

*Boost PFM Mode*

The FAN48695 has PFM operation which improves efficiency at light loads. The device operates in PFM when the load current falls below approximately 80 mA. In PFM mode, the average output voltage is regulated higher than the average PWM output voltage to improve transient dips.

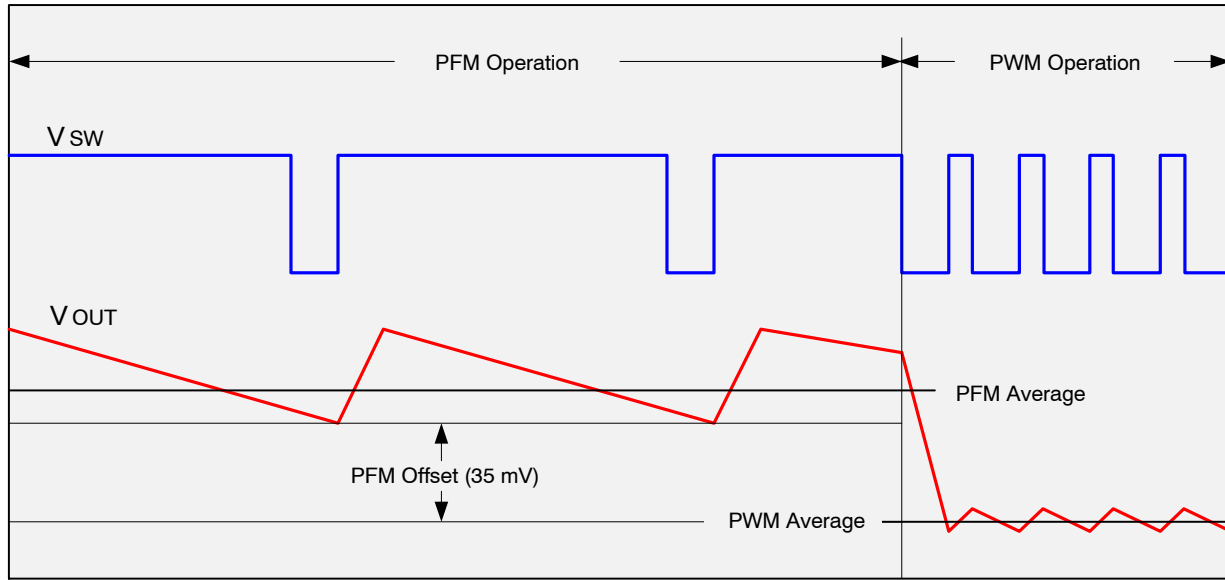

**Figure 19. Boost Mode Operation**

*Automatic Pass-Through Operation*

In normal operation, the device automatically transitions from Boost Mode to Pass-Through Operation if V<sub>IN</sub> is more than the boost target voltage minus 250 mV for ≥5 μsec. In Pass-Through Mode, the device has a low impedance path between V<sub>IN</sub> and V<sub>OUT</sub> (R<sub>DS(ON)\_P</sub> + L<sub>DCR</sub>). The device will automatically exit Pass-Through Mode when V<sub>IN</sub> is 350 mV less than the target boost voltage.

*Forced Pass-Through Mode*

When the PT pin is set to a logic HIGH and EN=HIGH, Forced Pass-Through mode occurs. In Pass-Through Mode, the device has a low impedance path between V<sub>IN</sub> and V<sub>OUT</sub> (R<sub>DS(ON)\_P</sub> + L<sub>DCR</sub>).

## Protection Features

### *V<sub>OUT</sub> Fault*

If the output voltage is pulled down to 300 mV below  $V_{IN}$  by a heavy load, the device will fault to protect itself, the source, and the load.

### *Soft Start Fault*

Refer to the Start-up section for additional detail. If the device fails to drive the output up to  $V_{IN} - 300$  mV within 1.5 ms the device will fault due to sensing a heavy load. If the device is unable to bring the output up to regulation within 100  $\mu$ s after exiting the linear charging phases, the device will fault. In either case, the device will attempt a restart 20 ms later.

### *Current Limit (OCP)*

FAN48695 has a current limit feature which protects itself, the inductor, and load during overload conditions. When the inductor peak current limit is reached and held for 2 ms, the device enters fault state.

During an output overload condition, if  $V_{OUT}$  falls 300 mV below  $V_{IN}$  the device enters fault state without waiting 2 ms.

In fault state, Q2 is completely opened to prevent current flow between PVIN and VOUT, in either direction. The device will attempt an automatic restart every 20 ms.

### *Automatic Pass-Through Mode Protection*

During Automatic Pass-Through Mode, the device is short-circuit protected. If the voltage difference between  $V_{IN}$  and  $V_{OUT}$  exceed more than 350 mV for  $\leq 10$   $\mu$ s, a fault is declared. The part will automatically attempt a restart every 20ms until the short condition ceases.

### *Forced Pass-Through Mode Protection*

In Forced Pass-Through Mode, fault protection occurs when  $V_{OUT}$  is dragged below  $V_{IN} - 450$  mV. The device will automatically attempt a restart every 20 ms.

### *Thermal Shutdown (TSD)*

When the die temperature increases, due to a high load condition and/or a rising ambient temperature, the output switching is disabled until the die temperature falls to the hysteresis threshold. The junction temperature at which the thermal shutdown activates is nominally  $T_{SD}$  with  $T_{HYS}$  hysteresis.

### *Under-Voltage Lockout (UVLO)*

If the EN pin is HIGH, once rising  $V_{IN}$  reaches  $V_{UVLO\_R}$ , the part will begin the Soft Start process. When falling  $V_{IN}$  reaches  $V_{UVLO\_F}$ , the output will go to a high Z state and the output voltage will decay into the prevailing load.

## External Component Selection

Refer to Table 2: Recommended External Components.

### *Output Capacitance (C<sub>OUT</sub>)*

It is recommended to use the output capacitor shown in the Recommended External Components table. If a different component is chosen, it is important that its effective capacitance is equal to or greater than that of the recommended component. See the Recommended Operating Conditions table for details. For better ripple performance, additional output capacitance can be added.

### *Output Voltage Ripple*

Output voltage ripple is inversely proportional to  $C_{OUT}$ . During  $t_{ON}$ , when the boost switch is on, all load current is supplied by  $C_{OUT}$ .

$$V_{RIPPLE(P-P)} = t_{ON} \cdot \frac{I_{LOAD}}{C_{OUT}} \quad (\text{eq. 1})$$

And

$$t_{ON} = t_{SW} \cdot D = t_{SW} \cdot \left(1 - \frac{V_{IN}}{V_{OUT}}\right) \quad (\text{eq. 2})$$

therefore:

$$V_{RIPPLE(P-P)} = t_{SW} \cdot \left(1 - \frac{V_{IN}}{V_{OUT}}\right) \cdot \frac{I_{LOAD}}{C_{OUT}} \quad (\text{eq. 3})$$

$$t_{SW} = \frac{1}{f_{SW}} \quad (\text{eq. 4})$$

For better ripple performance, more output capacitance can be added.

### *Input Capacitance (C<sub>IN</sub>)*

The 10 $\mu$ F ceramic 0402 input capacitor should be placed as close as possible between the PV<sub>IN</sub> pin and GND to minimize the parasitic inductance.

NOTE: The effective capacitance value decreases as  $V_{IN}$  increases due to DC bias effects. A high quality capacitor with ample voltage rating should be used for  $C_{IN}$ .

### *Inductor (L1)*

The FAN48695 employs peak current limiting and there is a finite amount of time between when the peak current is detected and when the switch turns off. During overload conditions, peak currents will be safely limited to  $I_{SW\_LIM}$  when using a properly rated inductor. Saturation effects should be considered during inductor selection.

# FAN48695

## Layout Guideline

The Recommended Layout shows all components on the top layer, top copper in RED and bottom copper in BLUE.

For thermal reasons, it is recommended to maximize the pour area for all planes other than SW.

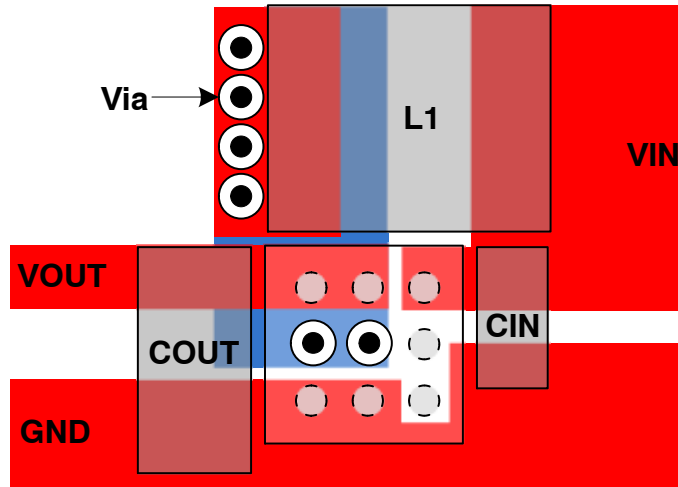
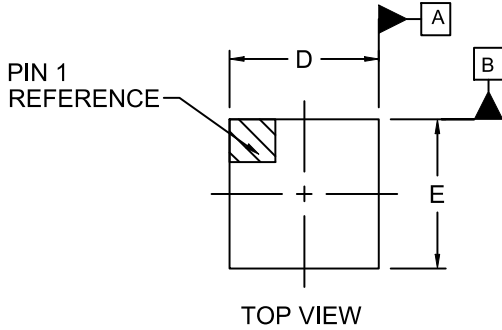

Figure 20. Recommended Layout

# FAN48695

## PACKAGE DIMENSIONS

WLCSP9, 1.365x1.315x0.586  
CASE 567VH  
ISSUE O



### NOTES:

1. DIMENSIONING AND TOLERANCING PER ASME Y14.5M, 2009.
2. CONTROLLING DIMENSION: MILLIMETERS
3. DATUM C APPLIES TO THE SPHERICAL CROWN OF THE SOLDER BALLS

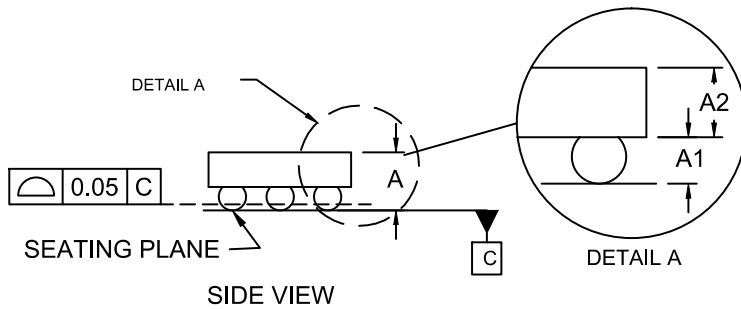

| DIM | MILLIMETERS |       |       |
|-----|-------------|-------|-------|
|     | MIN.        | NOM.  | MAX.  |
| A   | 0.548       | 0.586 | 0.624 |
| A1  | 0.188       | 0.208 | 0.228 |
| A2  | 0.360       | 0.378 | 0.396 |
| b   | 0.240       | 0.260 | 0.280 |
| D   | 1.335       | 1.365 | 1.395 |
| E   | 1.285       | 1.315 | 1.345 |
| e   | 0.40 BSC    |       |       |
| x   | 0.268       | 0.283 | 0.298 |
| y   | 0.243       | 0.258 | 0.273 |

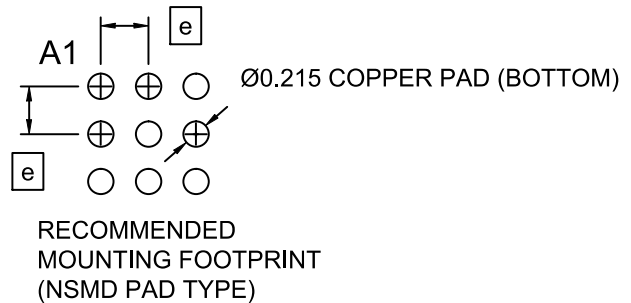
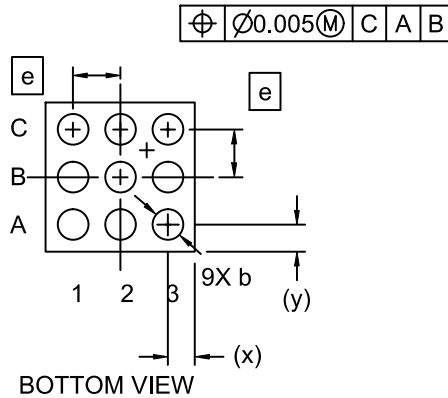



Table 8. PRODUCT SPECIFIC DIMENSIONS

| D        | E        | X         | Y         |
|----------|----------|-----------|-----------|
| 1.365 mm | 1.315 mm | 0.2825 mm | 0.2575 mm |

TINYBOOST is a registered trademark of of Semiconductor Components Industries, LLC (SCILLC) or its subsidiaries in the United States and/or other countries. All other brand names and product names appearing in this document are registered trademarks or trademarks of their respective holders.

ON Semiconductor and  are trademarks of Semiconductor Components Industries, LLC dba ON Semiconductor or its subsidiaries in the United States and/or other countries. ON Semiconductor owns the rights to a number of patents, trademarks, copyrights, trade secrets, and other intellectual property. A listing of ON Semiconductor's product/patent coverage may be accessed at [www.onsemi.com/site/pdf/Patent-Marking.pdf](http://www.onsemi.com/site/pdf/Patent-Marking.pdf). ON Semiconductor reserves the right to make changes without further notice to any products herein. ON Semiconductor makes no warranty, representation or guarantee regarding the suitability of its products for any particular purpose, nor does ON Semiconductor assume any liability arising out of the application or use of any product or circuit, and specifically disclaims any and all liability, including without limitation special, consequential or incidental damages. Buyer is responsible for its products and applications using ON Semiconductor products, including compliance with all laws, regulations and safety requirements or standards, regardless of any support or applications information provided by ON Semiconductor. "Typical" parameters which may be provided in ON Semiconductor data sheets and/or specifications can and do vary in different applications and actual performance may vary over time. All operating parameters, including "Typicals" must be validated for each customer application by customer's technical experts. ON Semiconductor does not convey any license under its patent rights nor the rights of others. ON Semiconductor products are not designed, intended, or authorized for use as a critical component in life support systems or any FDA Class 3 medical devices or medical devices with a same or similar classification in a foreign jurisdiction or any devices intended for implantation in the human body. Should Buyer purchase or use ON Semiconductor products for any such unintended or unauthorized application, Buyer shall indemnify and hold ON Semiconductor and its officers, employees, subsidiaries, affiliates, and distributors harmless against all claims, costs, damages, and expenses, and reasonable attorney fees arising out of, directly or indirectly, any claim of personal injury or death associated with such unintended or unauthorized use, even if such claim alleges that ON Semiconductor was negligent regarding the design or manufacture of the part. ON Semiconductor is an Equal Opportunity/Affirmative Action Employer. This literature is subject to all applicable copyright laws and is not for resale in any manner.

**PUBLICATION ORDERING INFORMATION**

**LITERATURE FULFILLMENT:**

Literature Distribution Center for ON Semiconductor  
19521 E. 32nd Pkwy, Aurora, Colorado 80011 USA  
**Phone:** 303-675-2175 or 800-344-3860 Toll Free USA/Canada  
**Fax:** 303-675-2176 or 800-344-3867 Toll Free USA/Canada  
**Email:** [orderlit@onsemi.com](mailto:orderlit@onsemi.com)

**N. American Technical Support:** 800-282-9855 Toll Free  
USA/Canada  
**Europe, Middle East and Africa Technical Support:**  
Phone: 421 33 790 2910

**ON Semiconductor Website:** [www.onsemi.com](http://www.onsemi.com)  
**Order Literature:** <http://www.onsemi.com/orderlit>

For additional information, please contact your local Sales Representative