

# EX-30 SERIES

## Threaded Miniature Photoelectric Sensor



The next-generation  
New Form series.  
A new alternative to  
fiber sensors.

**CE Marked**  
Conforming to EMC Directive

The EX-30 series have a radically new form which has been developed in response to the many calls for sensors to be easier to install. This new form which fits into the mounting holes for the M4 thru-beam type and M6 reflective type of sensors with their standard fiber sizes represents an improvement in previous design and installation techniques, so that these new sensors can be incorporated into the production line as-is.

### Simpler design

All you need to do is make a  $\varnothing 4\text{mm}$  hole where you would like to stop or check the workpiece ( $\varnothing 6\text{mm}$  hole for reflective type).

Furthermore, the center of the sensing axis is the same as the center of the mounting hole, which makes it much easier to set the sensing position.

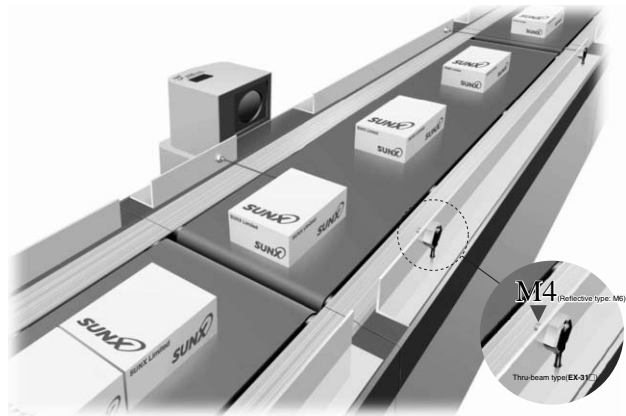

### New Concept in Shape

#### Can Be Installed in the Same Way as Standard Fibers

The EX-30 series can be screw-mounted (M4 for thru-beam type, M6 for reflective type) in the same way as standard fiber sensors. This means that they can be inserted into production lines in exactly the same way as conventional high-priced fiber sensors.



## New Design Solves All Weak Points of Fiber Sensors

### The EX-30 Series Solves All of the Difficulties Associated with Fiber Sensors, Such as:

- Difficulty finding a suitable place for the amplifier
- Fragility of the fiber
- Extra space needed because of difficulty in bending the fiber
- The nuisance of having to use a protective tube to prevent fiber breakages

### No amplifier needed

The amplifier is built in, so a separate amplifier is not required.

### Low Price

The recommended price is much lower than the price for fiber sensor sets.

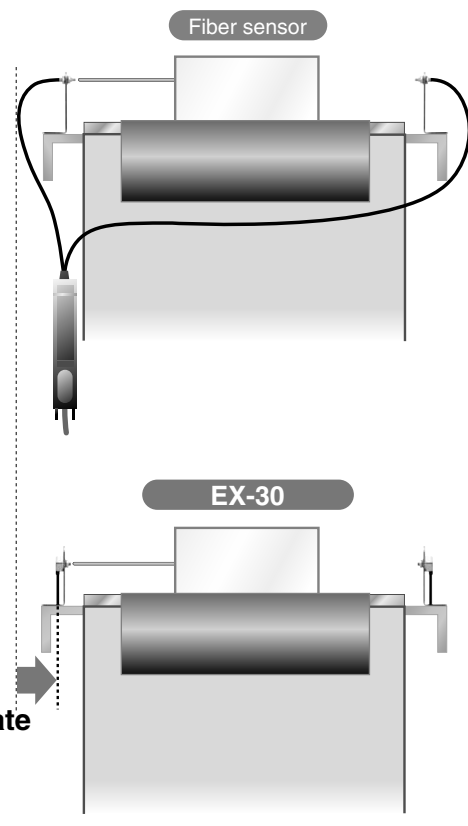

**No separate amplifier needed!**

### Unbreakable

A cabtyre cable is used, so that the sensor cable will not break like conventional fibers.

### Takes up very little space

Unlike conventional fibers, bending radius is not a problem, so that the sensor can be securely installed alongside conveyors.

### No protective tube needed

The EX-30 series has high bending strength, so that the protective tube used to protect conventional fiber from breakage are not needed. This also adds up to excellent cost performance.

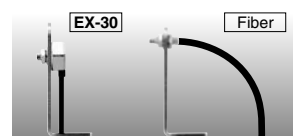

# EX-30

## Single-point Tightening Cuts Down on Installation Work by Half

Conventional photoelectric sensors required four (for thru-beam type) or two (for reflective type) mounting holes and screws to be used. However, the EX-30 series is installed with a single screw, thus cutting down on installation work by half.

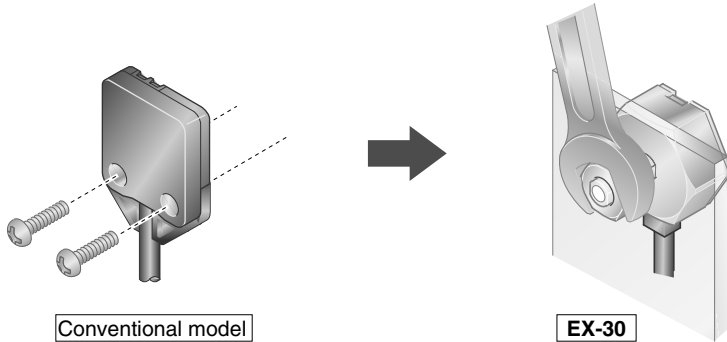

## Long Sensing Range

The EX-30 series achieves long distance sensing [thru-beam type: 500mm, reflective type: 50mm.]

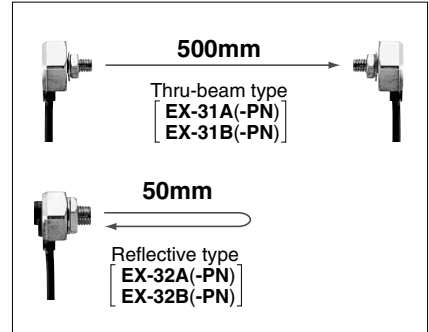

## Incorporates a Sensitivity Adjuster

(Reflective type only)

The sensor incorporates a sensitivity adjuster. It is convenient when you need fine adjustment.



## Bright 2-color Indicator

A bright 2-color indicator has been incorporated in all types.

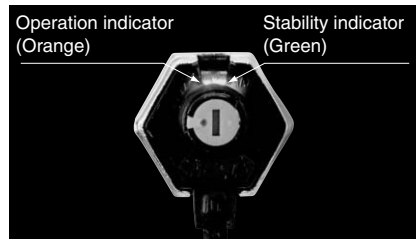

## Globally Useable

It conforms to the EMC Directive and obtains UL Recognition.

Moreover, PNP output type which is much demand in Europe, is also available.



## Waterproof

The sensor can be hosed down because of its IP67 construction.

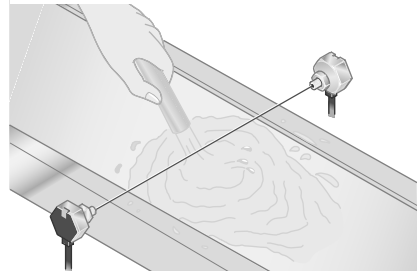

Note: However, take care that if it is exposed to water splashes during operation, it may detect a water drop itself.

## High Response Speed of 0.5ms

The same high response speed of 0.5ms as fiber sensor amplifiers is provided, making these sensors ideal for sensing small objects, counting objects that are moving quickly and positioning items such as circuit boards.

## Separate Slit Masks Also Available

A slit mask can be attached to narrow the beam width down to  $\phi 1$ mm to allow sensing of very small objects.

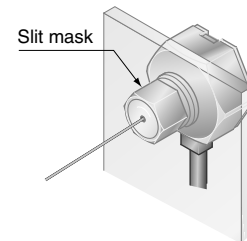

## Applications

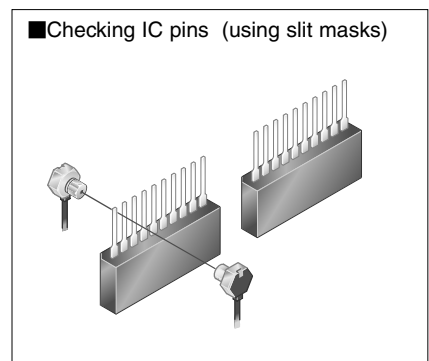
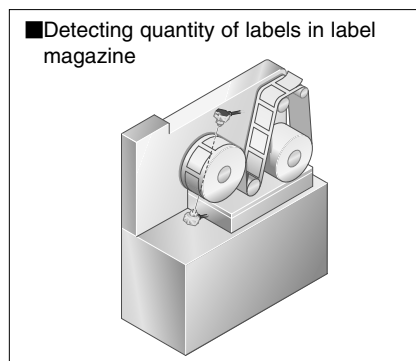
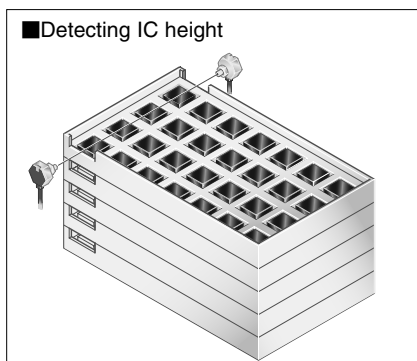

## ORDER GUIDE

Type	Appearance	Sensing range	Model No.	Output	Output operation
Thru-beam		500mm	EX-31A	NPN open-collector transistor	Light-ON
			EX-31B		Dark-ON
			EX-31A-PN	PNP open-collector transistor	Light-ON
			EX-31B-PN		Dark-ON
Diffuse reflective		50mm	EX-32A	NPN open-collector transistor	Light-ON
			EX-32B		Dark-ON
			EX-32A-PN	PNP open-collector transistor	Light-ON
			EX-32B-PN		Dark-ON

## OPTION

Designation	Model No.	Description
Slit mask	OS-EX30-1 (Slit size $\phi$ 1mm)	Slit on one side <ul style="list-style-type: none"> <li>• Sensing range: 200mm</li> <li>• Min. sensing object: <math>\phi</math> 2mm</li> </ul>
		Slit on both sides <ul style="list-style-type: none"> <li>• Sensing range: 150mm</li> <li>• Min. sensing object: <math>\phi</math> 1mm</li> </ul>

Slit mask

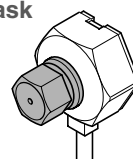

Note: One slit and two spacers are provided per set. Two sets are required when installing on both sides.

## SPECIFICATIONS

Item	Type		Thru-beam		Diffuse reflective		
	Model No.	NPN output PNP output	EX-31A EX-31A-PN	EX-31B EX-31B-PN	EX-32A EX-32A-PN	EX-32B EX-32B-PN	
Sensing range			500mm		50mm (Note)		
Sensing object			$\phi$ 2mm or more opaque object		Opaque, translucent or transparent object		
Hysteresis			—		15% or less of operation distance		
Repeatability (perpendicular to sensing axis)			0.05mm or less		0.5mm or less		
Supply voltage			12 to 24V DC $\pm$ 10%		Ripple P-P10% or less		
Current consumption			Emitter: 10mA or less, Receiver: 15mA or less		20mA or less		
Output			<NPN output type> NPN open-collector transistor <ul style="list-style-type: none"> <li>• Maximum sink current: 50mA</li> <li>• Applied voltage: 30V DC or less (between output and 0V)</li> <li>• Residual voltage: 1V or less (at 50mA sink current) 0.4V or less (at 16mA sink current)</li> </ul>		<PNP output type> PNP open-collector transistor <ul style="list-style-type: none"> <li>• Maximum source current: 50mA</li> <li>• Applied voltage: 30V DC or less (between output and +V)</li> <li>• Residual voltage: 1V or less (at 50mA source current) 0.4V or less (at 16mA source current)</li> </ul>		
	Utilization category			DC-12 or DC-13			
	Output operation			Light-ON	Dark-ON	Light-ON	Dark-ON
	Short-circuit protection			Incorporated			
Response time			0.5ms or less				
Operation indicator			Orange LED (lights up when the output is ON) (incorporated on the receiver for thru-beam type)				
Stability indicator			Green LED (lights up under stable light received condition or stable dark condition, incorporated on the receiver)		Green LED (lights up under stable light received condition or stable dark condition)		
Sensitivity adjuster			—		Continuously variable adjuster		
Environmental resistance	Pollution degree			3 (Industrial environment)			
	Protection			IP67 (IEC)			
	Ambient temperature			- 25 to + 55°C (No dew condensation or icing allowed), Storage: - 30 to + 70°C			
	Ambient humidity			35 to 85% RH, Storage: 35 to 85% RH			
	Ambient illuminance			Sunlight: 10,000 lx at the light-receiving face, Incandescent light: 3,000 lx at the light-receiving face			
	EMC			Emission: EN50081-2, Immunity: EN50082-2			
	Voltage withstandability			1,000V AC for one min. between all supply terminals connected together and enclosure			
	Insulation resistance			20M $\Omega$ , or more, with 250V DC megger between all supply terminals connected together and enclosure			
	Vibration resistance			10 to 500Hz frequency, 3mm amplitude (20G max.) in X, Y and Z directions for two hours each			
Shock resistance			500m/s <sup>2</sup> acceleration (50G approx.) in X, Y and Z directions for three times each				
Emitting element			Red LED (modulated)				
Material			Enclosure: Die-cast zinc(Nickel plated), Lens: Polycarbonate [EX-31□(-PN)], Acrylic [EX-32□(-PN)], Enclosure cover: Polycarbonate				
Cable			0.1mm <sup>2</sup> 3-core (thru-beam type sensor emitter: 2-core) cabtyre cable, 2m long				
Cable extension			Extension up to total 50m is possible with 0.3mm <sup>2</sup> , or more, cable (thru-beam type: both emitter and receiver).				
Weight			Emitter: 20g approx., Receiver: 20g approx.		20g approx.		
Accessories			Nut: 2 Nos., Toothed lock washer: 2 Nos.		Nut: 1 No., Toothed lock washer: 1 No.		

Note: The sensing range is specified of white non-glossy paper (100 × 100mm) as the object.

# EX-30

## I/O CIRCUIT AND WIRING DIAGRAMS

### NPN output type

#### I/O circuit diagram

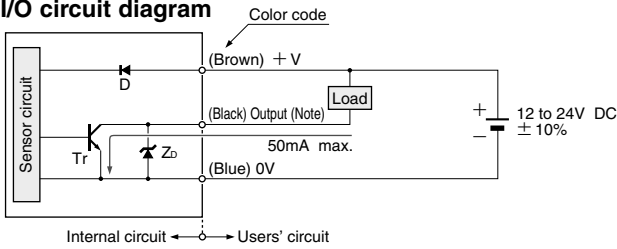

Note: The emitter of the thru-beam type sensor does not incorporate the output.

Symbols ... D: Reverse supply polarity protection diode  
Zb: Surge absorption zener diode  
Tr: NPN output transistor

#### Wiring diagram

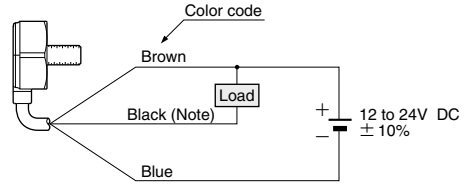

Note: The emitter of the thru-beam type sensor does not incorporate the black wire.

### PNP output type

#### I/O circuit diagram

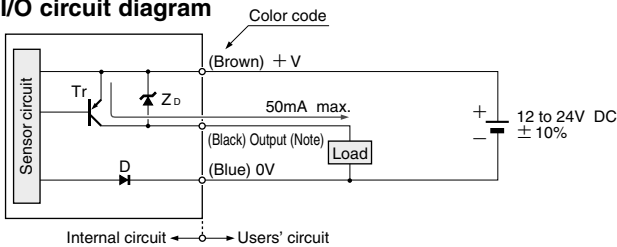

Note: The emitter of the thru-beam type sensor does not incorporate the output.

Symbols ... D: Reverse supply polarity protection diode  
Zb: Surge absorption zener diode  
Tr: PNP output transistor

#### Wiring diagram

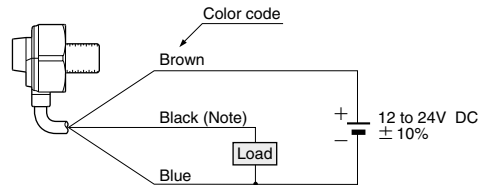

Note: The emitter of the thru-beam type sensor does not incorporate the black wire.

## SENSING CHARACTERISTICS (TYPICAL)

### EX-31 Thru-beam type

#### Parallel deviation

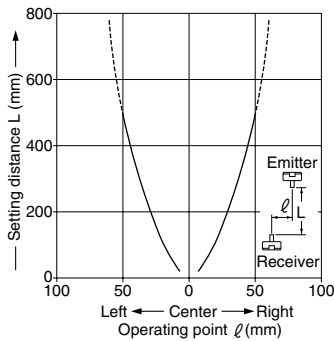

#### Angular deviation

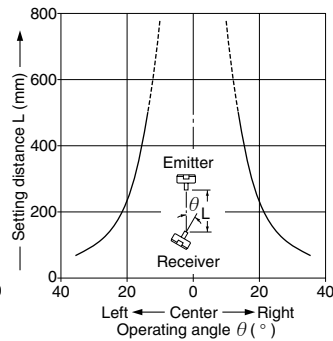

#### Parallel deviation with slit mask on one side

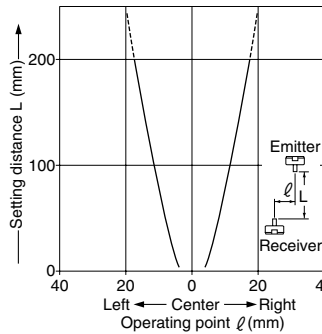

#### Parallel deviation with rectangular slit masks on both sides

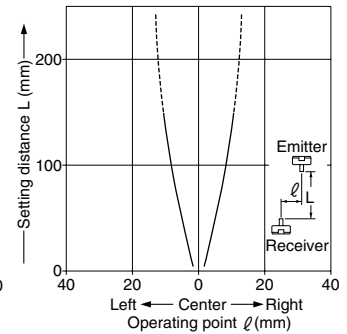

### EX-31 Thru-beam type

#### Correlation between setting distance and excess gain

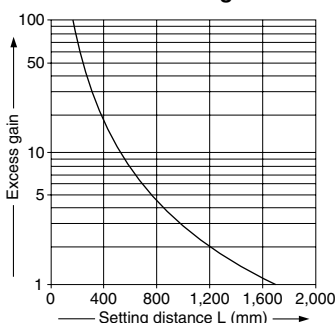

### EX-32 Diffuse reflective type

#### Sensing field

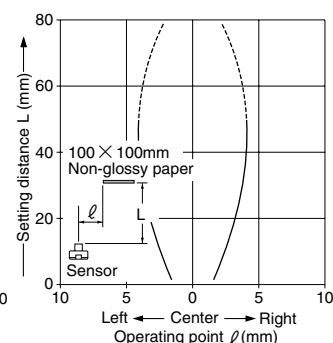

#### Correlation between sensing object size and sensing range

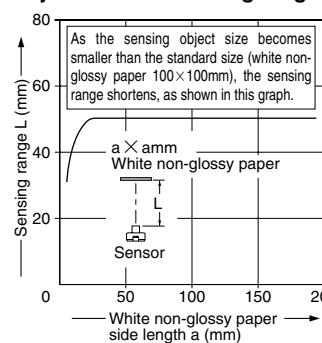

#### Correlation between setting distance and excess gain

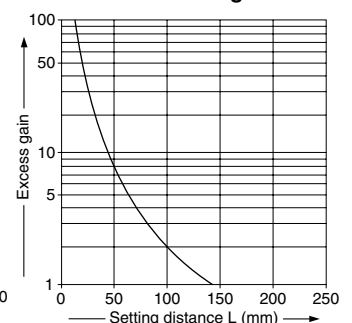

## PRECAUTIONS FOR PROPER USE



This product is not a safety sensor. Its use is not intended or designed to protect life and prevent body injury or property damage from dangerous parts of machinery. It is a normal object detection sensor.

### Part description

#### EX-31□, EX-31□-PN

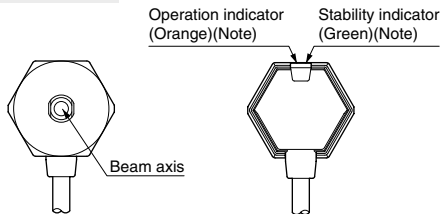

Note: Not incorporated on emitter.

#### EX-32□, EX-32□-PN

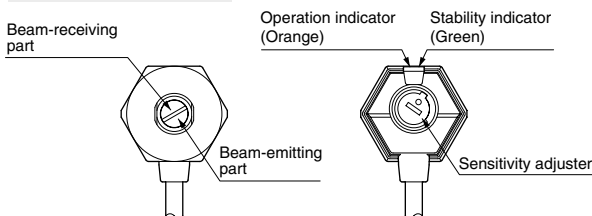

### Mounting

- Mount the sensor on a mounting plate 3mm or less thick, using the enclosed nut and toothed washer. When tightening the nut, hold the sensor with hand or a spanner and make sure that the tightening torque is 0.6N·m [EX-32□(-PN): 1.0N·m] or less. Do not tighten the sensor itself with a spanner, etc.

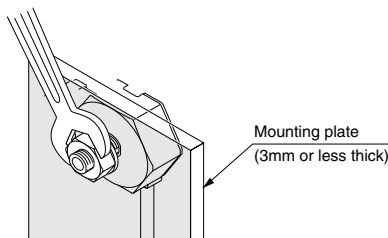

### Sensitivity adjustment (Diffuse reflective type only)

Step	Sensitivity adjuster	Description
①		Turn the sensitivity adjuster fully counterclockwise to the minimum sensitivity position.
②		In the light received condition, turn the sensitivity adjuster slowly clockwise and confirm the point (A) where the sensor enters the 'Light' state operation.
③		In the dark condition, turn the sensitivity adjuster further clockwise until the sensor enters the 'Light' state operation and then bring it back to confirm point (B) where the sensor just returns to the 'Dark' state operation. If the sensor does not enter the 'Light' state operation even when the sensitivity adjuster is turned fully clockwise, this extreme position is point (B).
④		The position at the middle of points (A) and (B) is the optimum sensing position.

Note: Use the accessory adjusting screwdriver to turn the adjuster slowly. Turning with excessive strength will damage the adjuster.

### Stability indicator

- The stability indicator (green) lights up when the incident light intensity has sufficient margin with respect to the operation level. If the incident light intensity level is such that the stability indicator lights up, stable sensing can be done without the light received operation and the light interrupted operation being affected by a change in ambient temperature or supply voltage.

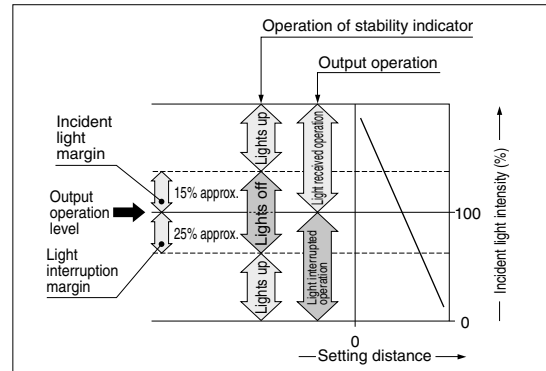

### Wiring

- Make sure to carry out the wiring in the power supply off condition.
- Verify that the supply voltage variation is within the rating.
- If power is supplied from a commercial switching regulator, ensure that the frame ground (F.G.) terminal of the power supply is connected to an actual ground.
- In case noise generating equipment (switching regulator, inverter motor, etc.) is used in the vicinity of this product, connect the frame ground (F.G.) terminal of the equipment to an actual ground.
- Extension up to total 50m (thru-beam type: both emitter and receiver) is possible with 0.3mm<sup>2</sup>, or more, cable. However, in order to reduce noise, make the wiring as short as possible.
- Do not run the wires together with high-voltage lines or power lines or put them in the same raceway. This can cause malfunction due to induction.
- Make sure to use an isolation transformer for the DC power supply. If an auto-transformer (single winding transformer) is used, this product or the power supply may get damaged.
- In case a surge is generated in the used power supply, connect a surge absorber to the supply and absorb the surge.

### Optional slit mask (Thru-beam type only)

- Apply the optional slit mask (OS-EX30-1) when detecting small objects or for increasing the accuracy of sensing position. However, the sensing range is reduced when the slit mask is mounted.

- Insert the sensor into the mounting plate.
- Fit the washer and spacers enclosed with the slit mask. Note that the number of spacers to be fitted differs with the mounting plate thickness, as give in the table below.
- Mount the slit mask. Make sure that the tightening torque is 0.6N·m or less.

Mounting plate thickness	No. of spacers
3mm	0 No.
2mm	1 No.
1mm	2 Nos.

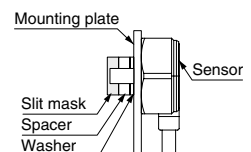

# EX-30

## PRECAUTIONS FOR PROPER USE

### Others

- Do not use during the initial transient time (50ms) after the power supply is switched on.
- Take care that the sensor is not directly exposed to fluorescent light from a rapid-starter lamp or a high frequency lighting device, as it may affect the sensing performance.
- Avoid dust, dirt, and steam.
- Take care that the sensor does not come in direct contact with water, oil, grease, or organic solvents, such as, thinner, etc.
- In case of using the sensor at a place where static electricity is generated, use a metal mounting plate. Also, ensure to ground the mounting plate.

## DIMENSIONS (Unit: mm)

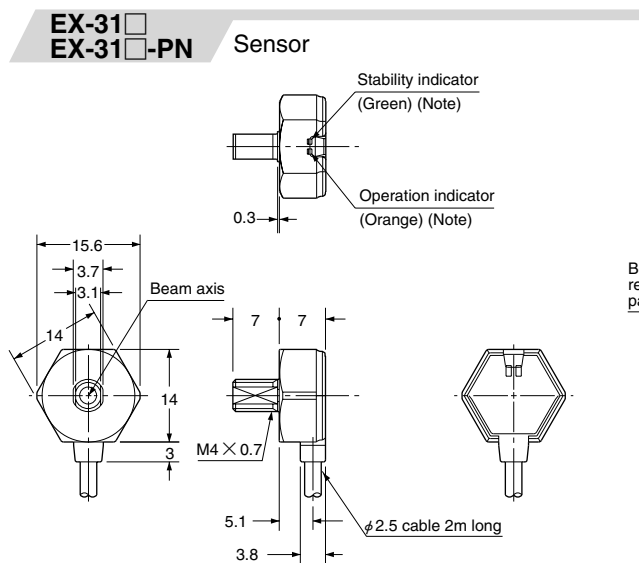

Note: Not incorporated on the emitter.

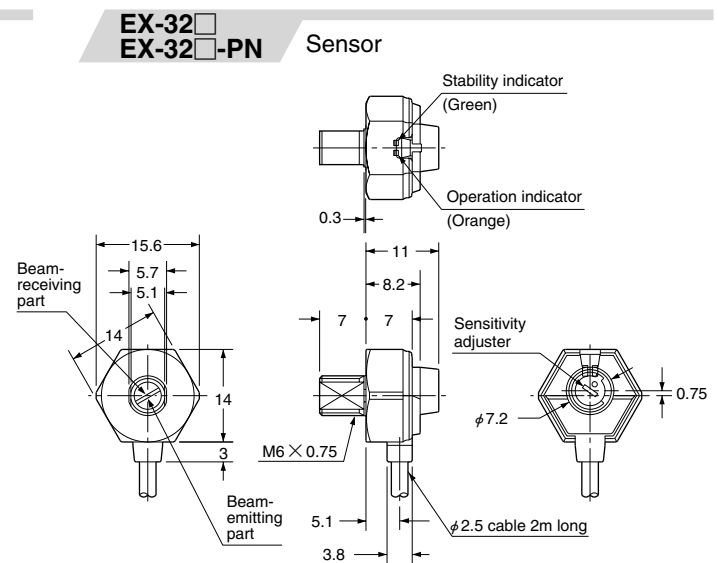

## OS-EX30-1 Slit mask (Optional)

### Slit mask

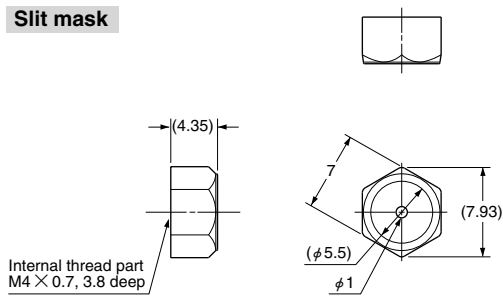

### Spacer

