



Identification &amp; Labeling &gt; Labels &gt; Safety Symbols &amp; Electrical Signs

Safety & Warning Symbol Type: **Warning High Voltage**Label Style: **Die-Cut**Label Adhesive Type: **Permanent Acrylic Adhesive**Product Width: **50 mm [ 1.969 in ]**Product Height: **42.54 mm [ 1.675 in ]**

## Features

### Product Type Features

Safety & Warning Symbol Type	Warning High Voltage
------------------------------	----------------------

### Body Features

Primary Product Color	Yellow
-----------------------	--------

Primary Product Material	Vinyl Film
--------------------------	------------

### Dimensions

Product Width	50 mm[1.969 in]
---------------	-----------------

Product Height	42.54 mm[1.675 in]
----------------	--------------------

### Usage Conditions

Operating Temperature Range	-30 – 120 °C[-22 – 249 °F]
-----------------------------	----------------------------

### Printer/Label Features

Number of Labels Across	2
-------------------------	---

Labels per Sheet	2
------------------	---

Label Style	Die-Cut
-------------	---------

Label Finish	Gloss
--------------	-------

### Packaging Features

Packaging Quantity	10
--------------------	----

Packaging Method	Box
------------------	-----

### Other

Label Adhesive Type

Permanent Acrylic Adhesive

## Product Compliance

[For compliance documentation, visit the product page on TE.com>](#)

EU RoHS Directive 2011/65/EU

Compliant

EU ELV Directive 2000/53/EC

Compliant

China RoHS 2 Directive MIIT Order No 32, 2016

No Restricted Materials Above Threshold

EU REACH Regulation (EC) No. 1907/2006

Current ECHA Candidate List: JUNE 2024 (241)  
 Candidate List Declared Against: JUNE 2024 (241)  
 Does not contain REACH SVHC

Halogen Content

Not Yet Reviewed for halogen content

Solder Process Capability

Not applicable for solder process capability

### Product Compliance Disclaimer

This information is provided based on reasonable inquiry of our suppliers and represents our current actual knowledge based on the information they provided. This information is subject to change. The part numbers that TE has identified as EU RoHS compliant have a maximum concentration of 0.1% by weight in homogenous materials for lead, hexavalent chromium, mercury, PBB, PBDE, DBP, BBP, DEHP, DIBP, and 0.01% for cadmium, or qualify for an exemption to these limits as defined in the Annexes of Directive 2011/65/EU (RoHS2). Finished electrical and electronic equipment products will be CE marked as required by Directive 2011/65/EU. Components may not be CE marked. Additionally, the part numbers that TE has identified as EU ELV compliant have a maximum concentration of 0.1% by weight in homogenous materials for lead, hexavalent chromium, and mercury, and 0.01% for cadmium, or qualify for an exemption to these limits as defined in the Annexes of Directive 2000/53/EC (ELV). Regarding the REACH Regulation, the information TE provides on SVHC in articles for this part number is based on the latest European Chemicals Agency (ECHA) 'Guidance on requirements for substances in articles' posted at this URL: <https://echa.europa.eu/guidance-documents/guidance-on-reach>

## Compatible Parts

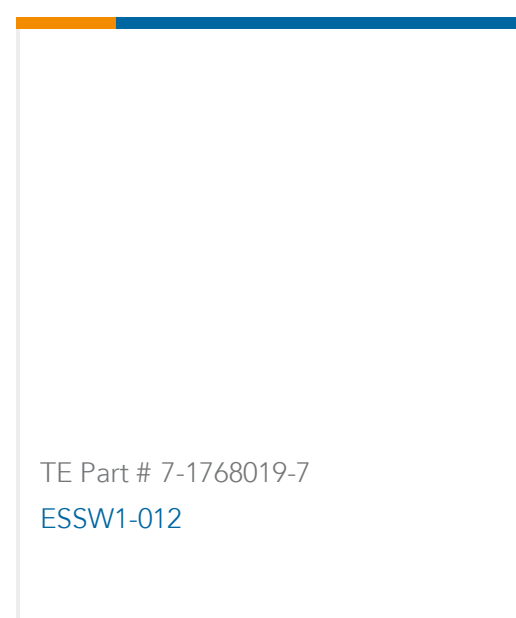

## Customers Also Bought

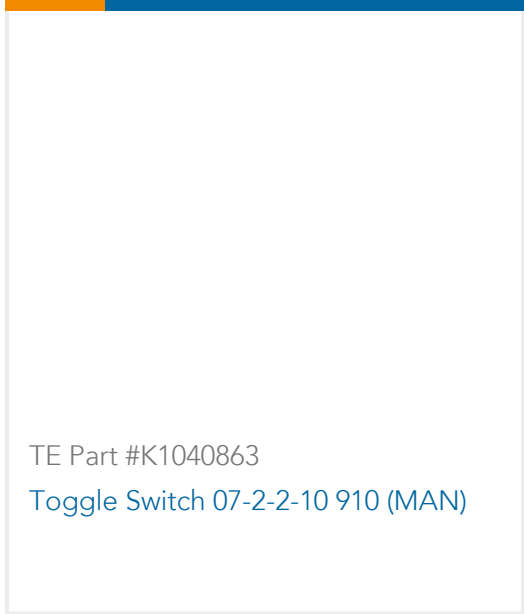
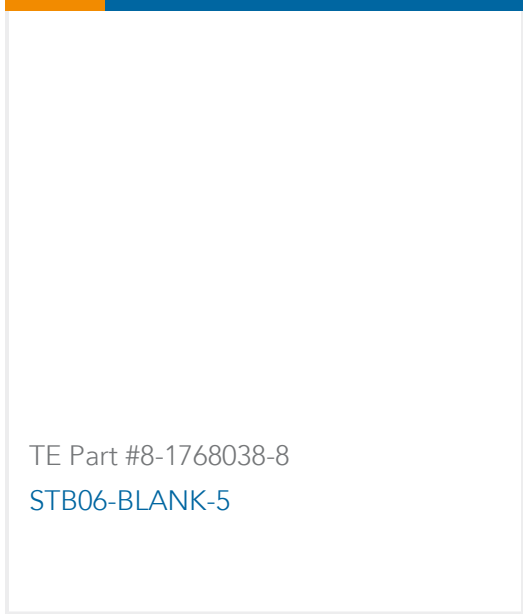
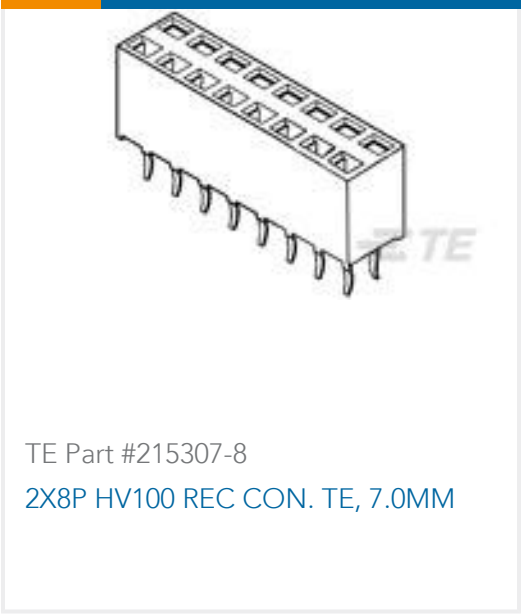

## Documents

### Product Drawings

[ESSW1-050](#)

English

### Datasheets & Catalog Pages

[IDENTIFICATION SELECTION GUIDE](#)

English

[SFATEY\\_AND\\_ELECTRICAL\\_SYMBOL\\_LABELS](#)

English