

Overview

The KEMET ESL single-ended aluminum electrolytic capacitors are designed for high reliability and long life (up to 10,000 hours) applications.

Applications

Typical applications include LED drive source.

Benefits

- Long life, up to 10,000 hours
- Operating temperature of up to +105°C
- Safety vent on the capacitor base

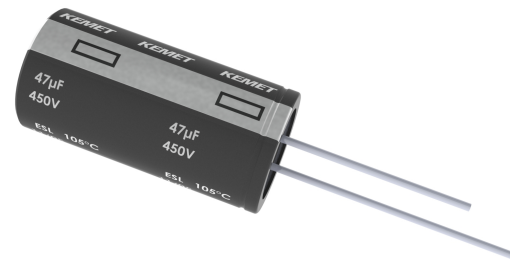

Part Number System

ESL	106	M	016		A	C3	AA
Series	Capacitance Code (pF)	Tolerance	Rated Voltage (VDC)		Electrical Parameters	Size Code	Packaging
Single-Ended Aluminum Electrolytic	First two digits represent significant figures for capacitance values. Last digit specifies the number of zeros to be added.	M = ±20%	016 = 16 025 = 25 035 = 35 050 = 50 063 = 63 100 = 100	160 = 160 200 = 200 250 = 250 350 = 350 400 = 400 450 = 450	A = Standard	See Dimension Table	See Ordering Options Table

Ordering Options Table

Diameter	Packaging Type	Lead Type	Lead Length (mm)	Lead and Packaging Code
Standard Bulk Packaging Options				
4 – 22	Bulk (bag)	Straight	20/15 Minimum	AA
Standard Auto-Insertion Packaging Options				
10 – 13	Ammo	5 mm lead spacing	$H_0 = 18.5 \pm 0.75$	EA
Other Packaging Options				
4 – 8	Ammo	Formed to 5 mm	$H_0 = 16 \pm 0.75$	DA
4 – 8	Ammo	Straight	$H_0 = 18.5 \pm 0.75$	EA
4 – 5	Ammo	Formed to 2.5 mm	$H_0 = 16 \pm 0.75$	FA
Contact KEMET for other lead and packaging options				

Environmental Compliance

As an environmentally conscious company, KEMET is working continuously with improvements concerning the environmental effects of both our capacitors and their production. In Europe (RoHS Directive) and in some other geographical areas like China, legislation has been put in place to prevent the use of some hazardous materials, such as lead (Pb), in electronic equipment. All products in this catalog are produced to help our customers' obligations to guarantee their products and fulfill these legislative requirements. The only material of concern in our products has been lead (Pb), which has been removed from all designs to fulfill the requirement of containing less than 0.1% of lead in any homogeneous material. KEMET will closely follow any changes in legislation world wide and make any necessary changes in its products, whenever needed.

Some customer segments such as medical, military and automotive electronics may still require the use of lead in electrode coatings. To clarify the situation and distinguish products from each other, a special symbol is used on the packaging labels for RoHS compatible capacitors.

Due to customer requirements, there may appear additional markings such as lead free (LF) or lead-free wires (LFW) on the label.

Dimensions – Millimeters

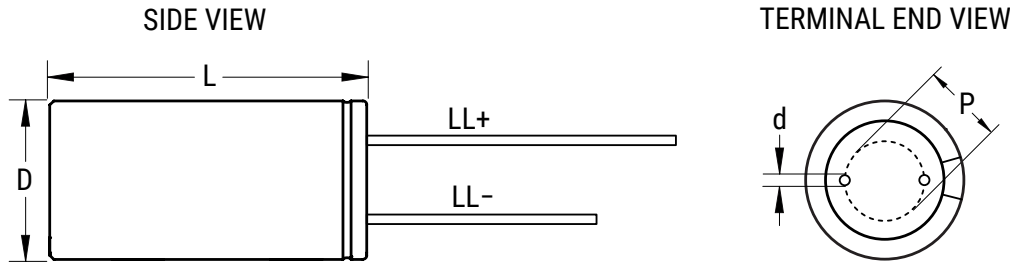

Size Code	D		L		p		d		LL+/LL-	
	Nominal	Tolerance	Nominal	Tolerance	Nominal	Tolerance	Nominal	Tolerance	Nominal	Tolerance
C3	5.0	±0.5	11.0	+1.5/-0	2.0	±0.5	0.5	Nominal	20/15	Minimum
E3	6.3	±0.5	11.0	+1.5/-0	2.5	±0.5	0.5	Nominal	20/15	Minimum
GM	8.0	±0.5	11.5	+2.0/-0	3.5	±0.5	0.6	Nominal	20/15	Minimum
G9	8.0	±0.5	12.0	+2.0/-0	3.5	±0.5	0.6	Nominal	20/15	Minimum
G8	8.0	±0.5	16.0	+2.0/-0	3.5	±0.5	0.6	Nominal	20/15	Minimum
G6	8.0	±0.5	20.0	+2.0/-0	3.5	±0.5	0.6	Nominal	20/15	Minimum
GG	8.0	±0.5	50.0	+2.0/-0	3.5	±0.5	0.6	Nominal	20/15	Minimum
H9	10.0	±0.5	12.5	+1.5/-0	5.0	±0.5	0.6	Nominal	20/15	Minimum
H8	10.0	±0.5	16.0	+2.0/-0	5.0	±0.5	0.6	Nominal	20/15	Minimum
H4	10.0	±0.5	20.0	+2.0/-0	5.0	±0.5	0.6	Nominal	20/15	Minimum
H5	10.0	±0.5	25.0	+2.0/-0	5.0	±0.5	0.6	Nominal	20/15	Minimum
HB	10.0	±0.5	40.0	+2.0/-0	5.0	±0.5	0.6	Nominal	20/15	Minimum
HE	10.0	±0.5	50.0	+2.0/-0	5.0	±0.5	0.6	Nominal	20/15	Minimum
K7	12.5	±0.5	15.0	+2.0/-0	5.0	±0.5	0.6	Nominal	20/15	Minimum
K5	12.5	±0.5	20.0	+2.0/-0	5.0	±0.5	0.6	Nominal	20/15	Minimum
K1	12.5	±0.5	25.0	+2.0/-0	5.0	±0.5	0.6	Nominal	20/15	Minimum
K2	12.5	±0.5	30.0	+2.0/-0	5.0	±0.5	0.6	Nominal	20/15	Minimum
K3	12.5	±0.5	35.0	+2.0/-0	5.0	±0.5	0.6	Nominal	20/15	Minimum
K4	12.5	±0.5	40.0	+2.0/-0	5.0	±0.5	0.6	Nominal	20/15	Minimum
KB	12.5	±0.5	50.0	+2.0/-0	5.0	±0.5	0.6	Nominal	20/15	Minimum
M5	16.0	±0.5	20.0	+2.0/-0	7.5	±0.5	0.8	Nominal	20/15	Minimum
M7	16.0	±0.5	25.0	+2.0/-0	7.5	±0.5	0.8	Nominal	20/15	Minimum
M9	16.0	±0.5	30.0	+2.0/-0	7.5	±0.5	0.8	Nominal	20/15	Minimum
MP	16.0	±0.5	35.0	+2.0/-0	7.5	±0.5	0.8	Nominal	20/15	Minimum
M4	16.0	±0.5	40.0	+2.0/-0	7.5	±0.5	0.8	Nominal	20/15	Minimum
N5	18.0	±0.5	25.0	+2.0/-0	7.5	±0.5	0.8	Nominal	20/15	Minimum
N8	18.0	±0.5	30.0	+2.0/-0	7.5	±0.5	0.8	Nominal	20/15	Minimum
NA	18.0	±0.5	35.0	+2.0/-0	7.5	±0.5	0.8	Nominal	20/15	Minimum
N3	18.0	±0.5	40.0	+2.0/-0	7.5	±0.5	0.8	Nominal	20/15	Minimum

Performance Characteristics

Item	Performance Characteristics	
Capacitance Range	0.47 – 6,800 μ F	
Capacitance Tolerance	\pm 20% at 120 Hz/20°C	
Rated Voltage	16 – 100 VDC	160 – 450 VDC
Life Test	8,000 – 10,000 hours (see conditions in Test Methods & Performance)	
Operating Temperature	-40°C to +105°C	
Leakage Current	$I \leq 0.01 CV$ or 3 μ A, whichever is greater	$I \leq 0.02 CV + 10 \mu$ A
	C = rated capacitance (μ F), V = rated voltage (VDC). Voltage applied for 2 minutes at 20°C.	

Impedance Z Characteristics at 120 Hz

Rated Voltage (VDC)	16	25	35	50	63	100	160	200	250	350	400	450
Z (-40°C)/Z (20°C)	8	6	6	6	4	4	6	6	6	7	7	9

Compensation Factor of Ripple Current (RC) vs. Frequency

Rated Voltage (VDC)	50 Hz	120 Hz	1 kHz	10 kHz	100 kHz
Coefficient	0.40	0.50	0.80	0.90	1.00

Test Method & Performance

Conditions	Load Life Test		Shelf Life Test
Temperature	105°C		105°C
Test Duration	16 – 100 VDC	Can \emptyset = 5 – 6 mm	8,000 hours
		Can \emptyset \geq 8 mm	10,000 hours
	160 – 450 VDC	10,000 hours	
Ripple Current	Maximum ripple current specified at 100 kHz 105°C		No ripple current applied
Voltage	The sum of DC voltage and the peak AC voltage must not exceed the rated voltage of the capacitor		No voltage applied
Performance	The following specifications will be satisfied when the capacitor is restored to 20°C:		
Capacitance Change	Within \pm 20% of the initial value		
Dissipation Factor	Does not exceed 200% of the specified value		
Leakage Current	Does not exceed specified value		

Shelf Life

The capacitance, ESR and impedance of a capacitor will not change significantly after extended storage periods, however, the leakage current will very slowly increase.

KEMET's E aluminum electrolytic capacitors should not be stored in high temperatures or where there is a high level of humidity. The suitable storage condition for KEMET's E aluminum electrolytic capacitors is +5 to +35°C and less than 75% in relative humidity. KEMET's E aluminum electrolytic capacitors should not be stored in damp conditions such as water, saltwater spray or oil spray. KEMET's E aluminum electrolytic capacitors should not be stored in an environment full of hazardous gas (hydrogen sulphide, sulphurous acid gas, nitrous acid, chlorine gas, ammonium, etc.) KEMET's E aluminum electrolytic capacitors should not be stored under exposure to ozone, ultraviolet rays or radiation.

If a capacitor has been stored for more than 18 months under these conditions and it shows increased leakage current, then a treatment by voltage application is recommended.

Re-Age (Reforming) Procedure

Apply the rated voltage to the capacitor at room temperature for a period of one hour, or until the leakage current has fallen to a steady value below the specified limit. During re-aging a maximum charging current of twice the specified leakage current or 5 mA, whichever is greater, is suggested.

Table 1 – Ratings & Part Number Reference

VDC	VDC Surge Voltage	Rated Capacitance 120 Hz 20°C (µF)	Case Size D x L (mm)	DF 120 Hz 20°C (tan δ %)*	RC 100 kHz 105°C (mA)	ESR 100 kHz 20°C (Ω)	LC 20°C 2 Minutes (µA)	Part Number
16	20	10	5x11	16	150	0.950	3.0	ESL106M016AC3(1)
16	20	15	5x11	16	155	0.950	3.0	ESL156M016AC3(1)
16	20	22	5x11	16	170	0.360	3.5	ESL226M016AC3(1)
16	20	33	5x11	16	185	0.360	5.3	ESL336M016AC3(1)
16	20	39	5x11	16	225	0.360	6.2	ESL396M016AC3(1)
16	20	47	5x11	16	245	0.230	7.5	ESL476M016AC3(1)
16	20	56	5x11	16	280	0.230	9.0	ESL566M016AC3(1)
16	20	68	5x11	16	305	0.230	10.9	ESL686M016AC3(1)
16	20	100	5x11	16	345	0.230	16.0	ESL107M016AC3(1)
16	20	120	6.3x11	16	485	0.098	19.2	ESL127M016AE3(1)
16	20	150	6.3x11	16	510	0.098	24.0	ESL157M016AE3(1)
16	20	180	6.3x11	16	525	0.098	28.8	ESL187M016AE3(1)
16	20	220	6.3x11	16	555	0.098	35.2	ESL227M016AE3(1)
16	20	270	8x11.5	16	870	0.061	43.2	ESL277M016AGM(1)
16	20	330	8x11.5	16	920	0.061	52.8	ESL337M016AGM(1)
16	20	390	8x11.5	16	940	0.061	62.4	ESL397M016AGM(1)
16	20	470	8x11.5	16	960	0.061	75.2	ESL477M016AGM(1)
16	20	560	10x12.5	16	1340	0.043	89.6	ESL567M016AH9(1)
16	20	560	8x16	16	1230	0.049	89.6	ESL567M016AG8(1)
16	20	680	10x12.5	16	1340	0.043	108.8	ESL687M016AH9(1)
16	20	680	8x16	16	1280	0.049	108.8	ESL687M016AG8(1)
16	20	820	10x16	16	1770	0.031	131.2	ESL827M016AH8(1)
16	20	820	8x20	16	1540	0.031	131.2	ESL827M016AG6(1)
16	20	1000	10x16	16	1770	0.031	160.0	ESL108M016AH8(1)
16	20	1000	8x20	16	1540	0.031	160.0	ESL108M016AG6(1)
16	20	1200	10x20	16	1970	0.022	192.0	ESL128M016AH4(1)
16	20	1200	12.5x15	16	2340	0.020	192.0	ESL128M016AK7(1)
16	20	1500	10x20	16	1970	0.022	240.0	ESL158M016AH4(1)
16	20	1500	12.5x15	16	2340	0.020	240.0	ESL158M016AK7(1)
16	20	1800	10x25	16	2260	0.020	288.0	ESL188M016AH5(1)
16	20	1800	12.5x20	16	2490	0.019	288.0	ESL188M016AK5(1)
16	20	2200	12.5x20	18	2490	0.019	352.0	ESL228M016AK5(1)
16	20	2700	12.5x25	18	2710	0.017	432.0	ESL278M016AK1(1)
16	20	3300	12.5x30	20	2960	0.014	528.0	ESL338M016AK2(1)
16	20	3300	16x20	20	2960	0.017	528.0	ESL338M016AM5AA
16	20	3900	12.5x30	20	3060	0.014	624.0	ESL398M016AK2(1)
16	20	3900	16x20	20	3060	0.017	624.0	ESL398M016AM5AA
16	20	4700	12.5x35	22	3280	0.013	752.0	ESL478M016AK3(1)
16	20	4700	16x25	22	3240	0.014	752.0	ESL478M016AM7AA
16	20	5600	16x30	24	3700	0.012	896.0	ESL568M016AM9AA
16	20	5600	18x25	24	3660	0.013	896.0	ESL568M016AN5AA
16	20	6800	16x30	26	3900	0.012	1088.0	ESL688M016AM9AA
16	20	6800	18x25	26	3860	0.013	1088.0	ESL688M016AN5AA
25	32	10	5x11	14	160	0.950	3.0	ESL106M025AC3(1)
25	32	15	5x11	14	170	0.950	3.8	ESL156M025AC3(1)
25	32	22	5x11	14	185	0.360	5.5	ESL226M025AC3(1)
25	32	33	5x11	14	200	0.360	8.3	ESL336M025AC3(1)
25	32	39	5x11	14	225	0.360	9.8	ESL396M025AC3(1)
25	32	47	5x11	14	315	0.230	11.8	ESL476M025AC3(1)
25	32	56	5x11	14	335	0.230	14.0	ESL566M025AC3(1)
25	32	68	5x11	14	355	0.230	17.0	ESL686M025AC3(1)
25	32	100	6.3x11	14	485	0.098	25.0	ESL107M025AE3(1)
25	32	120	6.3x11	14	525	0.098	30.0	ESL127M025AE3(1)
25	32	150	6.3x11	14	555	0.098	37.5	ESL157M025AE3(1)
25	32	180	8x11.5	14	875	0.061	45.0	ESL187M025AGM(1)
25	32	220	8x11.5	14	905	0.061	55.0	ESL227M025AGM(1)
25	32	270	8x11.5	14	965	0.061	67.5	ESL277M025AGM(1)
VDC	VDC Surge	Rated Capacitance	Case Size	DF	RC	ESR	LC	Part Number

(1) Insert packaging code. See Ordering Options Table for available options.

* When capacitance exceeds 1,000 µF, the DF value (%) is increased by 2% for every additional 1,000 µF.

Table 1 – Ratings & Part Number Reference cont.

VDC	VDC Surge Voltage	Rated Capacitance 120 Hz 20°C (µF)	Case Size D x L (mm)	DF 120 Hz 20°C (tan δ %)*	RC 100 kHz 105°C (mA)	ESR 100 kHz 20°C (Ω)	LC 20°C 2 Minutes (µA)	Part Number
25	32	330	8x11.5	14	965	0.061	82.5	ESL337M025AGM(1)
25	32	390	10x12.5	14	1340	0.043	97.5	ESL397M025AH9(1)
25	32	390	8x16	14	1280	0.049	97.5	ESL397M025AG8(1)
25	32	470	10x12.5	14	1325	0.043	117.5	ESL477M025AH9(1)
25	32	560	10x16	14	1770	0.031	140.0	ESL567M025AH8(1)
25	32	560	8x20	14	1540	0.031	140.0	ESL567M025AG6(1)
25	32	680	10x16	14	1770	0.031	170.0	ESL687M025AH8(1)
25	32	820	10x20	14	2010	0.020	205.0	ESL827M025AH4(1)
25	32	820	12.5x15	14	2010	0.020	205.0	ESL827M025AK7(1)
25	32	1000	10x25	14	2260	0.020	250.0	ESL108M025AH5(1)
25	32	1000	12.5x20	14	2260	0.019	250.0	ESL108M025AK5(1)
25	32	1200	12.5x20	14	2370	0.019	300.0	ESL128M025AK5(1)
25	32	1500	12.5x20	14	2490	0.019	375.0	ESL158M025AK5(1)
25	32	1800	12.5x25	14	2910	0.017	450.0	ESL188M025AK1(1)
25	32	2200	12.5x30	16	3460	0.014	550.0	ESL228M025AK2(1)
25	32	2200	16x20	16	3260	0.017	550.0	ESL228M025AM5AA
25	32	2700	12.5x35	16	3580	0.013	675.0	ESL278M025AK3(1)
25	32	2700	16x25	16	3640	0.014	675.0	ESL278M025AM7AA
25	32	3300	12.5x40	18	3900	0.012	825.0	ESL338M025AK4(1)
25	32	3300	16x25	18	3640	0.014	825.0	ESL338M025AM7AA
25	32	3900	16x30	18	3900	0.012	975.0	ESL398M025AM9AA
25	32	3900	18x25	18	3660	0.013	975.0	ESL398M025AN5AA
25	32	4700	16x35	20	3840	0.011	1175.0	ESL478M025AMPAA
25	32	4700	18x30	20	4020	0.011	1175.0	ESL478M025AN8AA
25	32	5600	18x35	22	4090	0.010	1400.0	ESL568M025ANAAA
25	32	6800	18x40	24	4160	0.010	1700.0	ESL688M025AN3AA
35	44	10	5x11	12	165	1.350	3.5	ESL106M035AC3(1)
35	44	15	5x11	12	175	0.950	5.3	ESL156M035AC3(1)
35	44	22	5x11	12	195	0.950	7.7	ESL226M035AC3(1)
35	44	33	5x11	12	205	0.360	11.6	ESL336M035AC3(1)
35	44	39	5x11	12	245	0.360	13.7	ESL396M035AC3(1)
35	44	47	5x11	12	345	0.230	16.5	ESL476M035AC3(1)
35	44	56	6.3x11	12	480	0.150	19.6	ESL566M035AE3(1)
35	44	68	6.3x11	12	520	0.130	23.8	ESL686M035AE3(1)
35	44	100	6.3x11	12	545	0.085	35.0	ESL107M035AE3(1)
35	44	120	8x11.5	12	780	0.078	42.0	ESL127M035AGM(1)
35	44	150	8x11.5	12	840	0.072	52.5	ESL157M035AGM(1)
35	44	180	8x11.5	12	965	0.068	63.0	ESL187M035AGM(1)
35	44	220	10x12.5	12	1180	0.043	77.0	ESL227M035AH9(1)
35	44	220	8x16	12	1020	0.048	77.0	ESL227M035AG8(1)
35	44	270	10x12.5	12	1210	0.043	94.5	ESL277M035AH9(1)
35	44	270	8x16	12	1050	0.048	94.5	ESL277M035AG8(1)
35	44	330	10x12.5	12	1340	0.043	115.5	ESL337M035AH9(1)
35	44	390	10x16	12	1650	0.030	136.5	ESL397M035AH8(1)
35	44	390	8x20	12	1520	0.030	136.5	ESL397M035AG6(1)
35	44	470	10x16	12	1755	0.030	164.5	ESL477M035AH8(1)
35	44	560	10x20	12	1970	0.030	196.0	ESL567M035AH4(1)
35	44	560	12.5x15	12	2340	0.025	196.0	ESL567M035AK7(1)
35	44	680	10x25	12	2260	0.024	238.0	ESL687M035AH5(1)
35	44	680	12.5x20	12	2360	0.024	238.0	ESL687M035AK5(1)
35	44	820	12.5x20	12	2490	0.024	287.0	ESL827M035AK5(1)
35	44	1000	12.5x20	12	2490	0.024	350.0	ESL108M035AK5(1)
35	44	1200	12.5x25	12	2910	0.023	420.0	ESL128M035AK1(1)
35	44	1500	12.5x30	12	3460	0.014	525.0	ESL158M035AK2(1)
35	44	1500	16x20	12	3260	0.022	525.0	ESL158M035AM5AA
35	44	1800	12.5x35	12	3470	0.012	630.0	ESL188M035AK3(1)
VDC	VDC Surge	Rated Capacitance	Case Size	DF	RC	ESR	LC	Part Number

(1) Insert packaging code. See Ordering Options Table for available options.

* When capacitance exceeds 1,000 µF, the DF value (%) is increased by 2% for every additional 1,000 µF.

Table 1 – Ratings & Part Number Reference cont.

VDC	VDC Surge Voltage	Rated Capacitance 120 Hz 20°C (µF)	Case Size D x L (mm)	DF 120 Hz 20°C (tan δ %)*	RC 100 kHz 105°C (mA)	ESR 100 kHz 20°C (Ω)	LC 20°C 2 Minutes (µA)	Part Number
35	44	1800	16x25	12	3580	0.021	630.0	ESL188M035AM7AA
35	44	2200	16x25	14	3640	0.020	770.0	ESL228M035AM7AA
35	44	2700	16x30	14	3540	0.011	945.0	ESL278M035AM9AA
35	44	2700	18x25	14	3650	0.011	945.0	ESL278M035AN5AA
35	44	3300	18x35	16	4090	0.010	1155.0	ESL338M035ANAAA
35	44	3900	18x40	16	4160	0.010	1365.0	ESL398M035AN3AA
50	63	10	5x11	10	185	1.350	5.0	ESL106M050AC3(1)
50	63	15	5x11	10	195	1.350	7.5	ESL156M050AC3(1)
50	63	22	5x11	10	240	0.550	11.0	ESL226M050AC3(1)
50	63	33	6.3x11	10	400	0.320	16.5	ESL336M050AE3(1)
50	63	39	6.3x11	10	400	0.230	19.5	ESL396M050AE3(1)
50	63	47	6.3x11	10	420	0.230	23.5	ESL476M050AE3(1)
50	63	56	6.3x11	10	385	0.120	28.0	ESL566M050AE3(1)
50	63	68	8x11.5	10	640	0.135	34.0	ESL686M050AGM(1)
50	63	100	8x11.5	10	725	0.120	50.0	ESL107M050AGM(1)
50	63	120	8x16	10	975	0.061	60.0	ESL127M050AG8(1)
50	63	150	8x16	10	975	0.061	75.0	ESL157M050AG8(1)
50	63	180	10x16	10	1380	0.046	90.0	ESL187M050AH8(1)
50	63	220	10x16	10	1380	0.042	110.0	ESL227M050AH8(1)
50	63	220	8x20	10	1320	0.041	110.0	ESL227M050AG6(1)
50	63	270	10x20	10	1590	0.036	135.0	ESL277M050AH4(1)
50	63	270	12.5x15	10	1762	0.038	135.0	ESL277M050AK7(1)
50	63	330	10x25	10	1650	0.036	165.0	ESL337M050AH5(1)
50	63	390	10x25	10	1880	0.031	195.0	ESL397M050AH5(1)
50	63	390	12.5x20	10	2060	0.030	195.0	ESL397M050AK5(1)
50	63	470	12.5x20	10	2050	0.030	235.0	ESL477M050AK5(1)
50	63	560	12.5x25	10	2420	0.020	280.0	ESL567M050AK1(1)
50	63	680	12.5x30	10	2860	0.021	340.0	ESL687M050AK2(1)
50	63	820	12.5x30	10	2870	0.022	410.0	ESL827M050AK2(1)
50	63	1000	12.5x35	10	3050	0.018	500.0	ESL108M050AK3(1)
50	63	1000	16x25	10	3010	0.020	500.0	ESL108M050AM7AA
50	63	1200	16x30	10	3290	0.018	600.0	ESL128M050AM9AA
50	63	1200	18x25	10	3070	0.025	600.0	ESL128M050AN5AA
50	63	1500	16x35	10	3050	0.018	750.0	ESL158M050AMPAA
50	63	1500	18x25	10	3310	0.023	750.0	ESL158M050AN5AA
50	63	1800	16x40	10	3440	0.016	900.0	ESL188M050AM4AA
50	63	1800	18x35	10	3520	0.021	900.0	ESL188M050ANAAA
50	63	2200	18x35	12	3580	0.021	1100.0	ESL228M050ANAAA
63	79	0.47	5x11	9	80	1.350	3.0	ESL474M063AC3(1)
63	79	1	5x11	9	95	1.350	3.0	ESL105M063AC3(1)
63	79	1.8	5x11	9	95	1.350	3.0	ESL185M063AC3(1)
63	79	2.2	5x11	9	105	1.350	3.0	ESL225M063AC3(1)
63	79	2.7	5x11	9	105	1.350	3.0	ESL275M063AC3(1)
63	79	3.3	5x11	9	115	1.350	3.0	ESL335M063AC3(1)
63	79	3.9	5x11	9	115	1.350	3.0	ESL395M063AC3(1)
63	79	4.7	5x11	9	120	1.350	3.0	ESL475M063AC3(1)
63	79	5.6	5x11	9	135	1.350	3.5	ESL565M063AC3(1)
63	79	6.8	5x11	9	135	1.350	4.3	ESL685M063AC3(1)
63	79	8.2	5x11	9	145	1.350	5.2	ESL825M063AC3(1)
63	79	10	5x11	9	145	1.350	6.3	ESL106M063AC3(1)
63	79	12	5x11	9	155	1.350	7.6	ESL126M063AC3(1)
63	79	15	5x11	9	165	1.350	9.5	ESL156M063AC3(1)
63	79	18	6.3x11	9	265	0.380	11.3	ESL186M063AE3(1)
63	79	22	6.3x11	9	295	0.380	13.9	ESL226M063AE3(1)
63	79	27	6.3x11	9	305	0.380	17.0	ESL276M063AE3(1)
63	79	33	6.3x11	9	335	0.380	20.8	ESL336M063AE3(1)
VDC	VDC Surge	Rated Capacitance	Case Size	DF	RC	ESR	LC	Part Number

(1) Insert packaging code. See Ordering Options Table for available options.

* When capacitance exceeds 1,000 µF, the DF value (%) is increased by 2% for every additional 1,000 µF.

Table 1 – Ratings & Part Number Reference cont.

VDC	VDC Surge Voltage	Rated Capacitance 120 Hz 20°C (µF)	Case Size D x L (mm)	DF 120 Hz 20°C (tan δ %)*	RC 100 kHz 105°C (mA)	ESR 100 kHz 20°C (Ω)	LC 20°C 2 Minutes (µA)	Part Number
63	79	39	8x11.5	9	420	0.230	24.6	ESL396M063AGM(1)
63	79	47	8x11.5	9	435	0.230	29.6	ESL476M063AGM(1)
63	79	56	8x11.5	9	445	0.230	35.3	ESL566M063AGM(1)
63	79	68	8x11.5	9	460	0.230	42.8	ESL686M063AGM(1)
63	79	82	8x16	9	560	0.170	51.7	ESL826M063AG8(1)
63	79	100	10x12.5	9	570	0.170	63.0	ESL107M063AH9(1)
63	79	100	8x16	9	580	0.170	63.0	ESL107M063AG8(1)
63	79	120	10x12.5	9	580	0.170	75.6	ESL127M063AH9(1)
63	79	150	10x16	9	705	0.190	94.5	ESL157M063AH8(1)
63	79	150	8x20	9	680	0.120	94.5	ESL157M063AG6(1)
63	79	180	10x16	9	725	0.190	113.4	ESL187M063AH8(1)
63	79	220	10x20	9	1050	0.086	138.6	ESL227M063AH4(1)
63	79	220	12.5x15	9	1020	0.080	138.6	ESL227M063AK7(1)
63	79	270	10x20	9	1080	0.086	170.1	ESL277M063AH4(1)
63	79	270	12.5x15	9	1045	0.080	170.1	ESL277M063AK7(1)
63	79	330	10x25	9	1250	0.076	207.9	ESL337M063AH5(1)
63	79	330	12.5x20	9	1320	0.066	207.9	ESL337M063AK5(1)
63	79	390	12.5x20	9	1350	0.066	245.7	ESL397M063AK5(1)
63	79	470	12.5x25	9	1860	0.047	296.1	ESL477M063AK1(1)
63	79	560	12.5x30	9	2050	0.039	352.8	ESL567M063AK2(1)
63	79	560	16x20	9	1980	0.047	352.8	ESL567M063AM5AA
63	79	680	12.5x35	9	2250	0.036	428.4	ESL687M063AK3(1)
63	79	680	16x25	9	2315	0.035	428.4	ESL687M063AM7AA
63	79	820	12.5x40	9	2430	0.030	516.6	ESL827M063AK4(1)
63	79	820	16x25	9	2480	0.035	516.6	ESL827M063AM7AA
63	79	1000	16x30	9	2620	0.026	630.0	ESL108M063AM9AA
63	79	1200	16x30	9	2650	0.026	756.0	ESL128M063AM9AA
63	79	1200	18x25	9	2610	0.034	756.0	ESL128M063AN5AA
63	79	1500	16x35	9	2730	0.023	945.0	ESL158M063AMPAA
63	79	1500	18x30	9	2780	0.028	945.0	ESL158M063AN8AA
63	79	1800	16x40	9	3250	0.021	1134.0	ESL188M063AM4AA
63	79	2200	18x40	11	3430	0.028	1386.0	ESL228M063AN3AA
100	125	0.47	5x11	9	95	1.850	3.0	ESL474M100AC3(1)
100	125	1	5x11	9	105	1.850	3.0	ESL105M100AC3(1)
100	125	1.8	5x11	9	105	1.800	3.0	ESL185M100AC3(1)
100	125	2.2	5x11	9	115	1.800	3.0	ESL225M100AC3(1)
100	125	2.7	5x11	9	115	1.800	3.0	ESL275M100AC3(1)
100	125	3.3	5x11	9	125	1.800	3.3	ESL335M100AC3(1)
100	125	3.9	5x11	9	135	1.800	3.9	ESL395M100AC3(1)
100	125	4.7	5x11	9	145	1.800	4.7	ESL475M100AC3(1)
100	125	5.6	6.3x11	9	205	1.250	5.6	ESL565M100AE3(1)
100	125	6.8	6.3x11	9	235	1.250	6.8	ESL685M100AE3(1)
100	125	8.2	6.3x11	9	255	1.050	8.2	ESL825M100AE3(1)
100	125	10	6.3x11	9	280	0.680	10.0	ESL106M100AE3(1)
100	125	12	8x11.5	9	320	0.390	12.0	ESL126M100AGM(1)
100	125	15	8x11.5	9	320	0.650	15.0	ESL156M100AGM(1)
100	125	18	8x11.5	9	345	0.600	18.0	ESL186M100AGM(1)
100	125	22	8x11.5	9	365	0.520	22.0	ESL226M100AGM(1)
100	125	27	10x12.5	9	460	0.560	27.0	ESL276M100AH9(1)
100	125	27	8x16	9	455	0.550	27.0	ESL276M100AG8(1)
100	125	33	10x12.5	9	475	0.480	33.0	ESL336M100AH9(1)
100	125	33	8x16	9	465	0.460	33.0	ESL336M100AG8(1)
100	125	39	10x12.5	9	485	0.380	39.0	ESL396M100AH9(1)
100	125	47	10x12.5	9	510	0.320	47.0	ESL476M100AH9(1)
100	125	56	10x12.5	9	540	0.280	56.0	ESL566M100AH9(1)
100	125	68	8x20	9	675	0.280	68.0	ESL686M100AG6(1)
VDC	VDC Surge	Rated Capacitance	Case Size	DF	RC	ESR	LC	Part Number

(1) Insert packaging code. See Ordering Options Table for available options.

* When capacitance exceeds 1,000 µF, the DF value (%) is increased by 2% for every additional 1,000 µF.

Table 1 – Ratings & Part Number Reference cont.

VDC	VDC Surge Voltage	Rated Capacitance 120 Hz 20°C (µF)	Case Size D x L (mm)	DF 120 Hz 20°C (tan δ %)*	RC 100 kHz 105°C (mA)	ESR 100 kHz 20°C (Ω)	LC 20°C 2 Minutes (µA)	Part Number
100	125	82	10x16	9	785	0.190	82.0	ESL826M100AH8(1)
100	125	100	10x20	9	865	0.130	100.0	ESL107M100AH4(1)
100	125	100	12.5x15	9	845	0.140	100.0	ESL107M100AK7(1)
100	125	120	10x25	9	1050	0.120	120.0	ESL127M100AH5(1)
100	125	150	12.5x20	9	1440	0.085	150.0	ESL157M100AK5(1)
100	125	180	12.5x25	9	1460	0.066	180.0	ESL187M100AK1(1)
100	125	220	12.5x25	9	1630	0.066	220.0	ESL227M100AK1(1)
100	125	270	12.5x30	9	1620	0.056	270.0	ESL277M100AK2(1)
100	125	270	16x20	9	1650	0.064	270.0	ESL277M100AM5AA
100	125	330	12.5x35	9	1950	0.047	330.0	ESL337M100AK3(1)
100	125	330	16x25	9	1920	0.048	330.0	ESL337M100AM7AA
100	125	390	12.5x40	9	2050	0.040	390.0	ESL397M100AK4(1)
100	125	470	16x30	9	2010	0.036	470.0	ESL477M100AM9AA
100	125	560	16x35	9	2430	0.032	560.0	ESL567M100AMPAA
100	125	560	18x30	9	2480	0.034	560.0	ESL567M100AN8AA
100	125	680	16x40	9	2680	0.030	680.0	ESL687M100AM4AA
100	125	680	18x35	9	2870	0.030	680.0	ESL687M100ANAAA
100	125	820	18x40	9	3250	0.028	820.0	ESL827M100AN3AA
160	200	1.8	6.3x11	15	65	13.940	15.8	ESL185M160AE3(1)
160	200	2.2	6.3x11	15	70	13.940	17.0	ESL225M160AE3(1)
160	200	2.7	6.3x11	15	75	13.940	18.6	ESL275M160AE3(1)
160	200	3.3	6.3x11	15	80	13.940	20.6	ESL335M160AE3(1)
160	200	3.9	6.3x11	15	85	13.940	22.5	ESL395M160AE3(1)
160	200	4.7	8x11.5	15	85	11.300	25.0	ESL475M160AGM(1)
160	200	5.6	8x11.5	15	100	11.300	27.9	ESL565M160AGM(1)
160	200	6.8	8x11.5	15	105	11.300	31.8	ESL685M160AGM(1)
160	200	8.2	8x11.5	15	115	11.300	36.2	ESL825M160AGM(1)
160	200	10	8x16	15	135	7.500	42.0	ESL106M160AG8(1)
160	200	12	8x16	15	140	7.500	48.4	ESL126M160AG8(1)
160	200	15	10x12.5	15	290	4.270	58.0	ESL156M160AH9(1)
160	200	15	8x16	15	285	4.270	58.0	ESL156M160AG8(1)
160	200	18	8x16	15	310	4.270	67.6	ESL186M160AG8(1)
160	200	22	10x16	15	390	2.250	80.4	ESL226M160AH8(1)
160	200	22	8x20	15	390	2.250	80.4	ESL226M160AG6(1)
160	200	27	10x16	15	410	2.250	96.4	ESL276M160AH8(1)
160	200	33	10x20	15	530	1.870	115.6	ESL336M160AH4(1)
160	200	33	12.5x15	15	570	1.870	115.6	ESL336M160AK7(1)
160	200	39	10x25	15	590	1.870	134.8	ESL396M160AH5(1)
160	200	39	12.5x15	15	590	1.870	134.8	ESL396M160AK7(1)
160	200	47	10x25	15	610	1.870	160.4	ESL476M160AH5(1)
160	200	47	12.5x20	15	630	1.870	160.4	ESL476M160AK5(1)
160	200	56	12.5x20	15	740	1.550	189.2	ESL566M160AK5(1)
160	200	56	8x50	15	740	1.550	189.2	ESL566M160AGG(1)
160	200	68	12.5x20	15	800	1.100	227.6	ESL686M160AK5(1)
160	200	82	12.5x25	15	830	1.100	272.4	ESL826M160AK1(1)
160	200	100	10x50	15	1210	1.100	330.0	ESL107M160AHE(1)
160	200	100	16x20	15	1120	1.100	330.0	ESL107M160AM5AA
160	200	120	16x25	15	1240	0.910	394.0	ESL127M160AM7AA
160	200	150	12.5x50	15	1280	0.910	490.0	ESL157M160AKB(1)
160	200	150	16x30	15	1280	0.910	490.0	ESL157M160AM9AA
160	200	180	16x30	15	1360	0.810	586.0	ESL187M160AM9AA
160	200	220	18x30	15	1410	0.810	714.0	ESL227M160AN8AA
160	200	270	18x35	15	1500	0.670	874.0	ESL277M160ANAAA
160	200	330	18x40	15	1590	0.670	1066.0	ESL337M160AN3AA
200	250	2.2	6.3x11	15	75	14.500	18.8	ESL225M200AE3(1)
200	250	2.7	6.3x11	15	80	14.500	20.8	ESL275M200AE3(1)
VDC	VDC Surge	Rated Capacitance	Case Size	DF	RC	ESR	LC	Part Number

(1) Insert packaging code. See Ordering Options Table for available options.

* When capacitance exceeds 1,000 µF, the DF value (%) is increased by 2% for every additional 1,000 µF.

Table 1 – Ratings & Part Number Reference cont.

VDC	VDC Surge Voltage	Rated Capacitance 120 Hz 20°C (µF)	Case Size D x L (mm)	DF 120 Hz 20°C (tan δ %)*	RC 100 kHz 105°C (mA)	ESR 100 kHz 20°C (Ω)	LC 20°C 2 Minutes (µA)	Part Number
200	250	3.3	6.3x11	15	95	10.150	23.2	ESL335M200AE3(1)
200	250	3.9	6.3x11	15	105	10.150	25.6	ESL395M200AE3(1)
200	250	4.7	8x11.5	15	130	10.150	28.8	ESL475M200AGM(1)
200	250	5.6	8x11.5	15	135	7.980	32.4	ESL565M200AGM(1)
200	250	6.8	8x11.5	15	145	7.980	37.2	ESL685M200AGM(1)
200	250	8.2	8x11.5	15	165	7.980	42.8	ESL825M200AGM(1)
200	250	10	8x12	15	175	3.650	50.0	ESL106M200AG9(1)
200	250	12	8x16	15	190	3.650	58.0	ESL126M200AG8(1)
200	250	15	8x16	15	360	3.650	70.0	ESL156M200AG8(1)
200	250	18	10x16	15	385	3.240	82.0	ESL186M200AH8(1)
200	250	22	10x16	15	390	3.240	98.0	ESL226M200AH8(1)
200	250	27	10x20	15	410	2.380	118.0	ESL276M200AH4(1)
200	250	33	10x25	15	530	1.650	142.0	ESL336M200AH5(1)
200	250	39	12.5x20	15	620	1.380	166.0	ESL396M200AK5(1)
200	250	47	12.5x20	15	630	1.380	198.0	ESL476M200AK5(1)
200	250	47	8x50	15	650	1.380	198.0	ESL476M200AGG(1)
200	250	56	10x50	15	670	1.250	234.0	ESL566M200AHE(1)
200	250	56	12.5x25	15	670	1.250	234.0	ESL566M200AK1(1)
200	250	68	12.5x30	15	850	1.250	282.0	ESL686M200AK2(1)
200	250	82	16x25	15	860	1.150	338.0	ESL826M200AM7AA
200	250	100	16x25	15	930	1.150	410.0	ESL107M200AM7AA
200	250	120	16x30	15	1090	1.030	490.0	ESL127M200AM9AA
200	250	150	16x35	15	1125	1.030	610.0	ESL157M200AMPAA
200	250	180	18x30	15	1340	0.800	730.0	ESL187M200AN8AA
200	250	220	18x35	15	1420	0.740	890.0	ESL227M200ANAAA
250	300	2.2	6.3x11	15	80	10.150	21.0	ESL225M250AE3(1)
250	300	2.7	6.3x11	15	90	10.150	23.5	ESL275M250AE3(1)
250	300	3.3	6.3x11	15	100	10.150	26.5	ESL335M250AE3(1)
250	300	3.9	8x11.5	15	110	10.150	29.5	ESL395M250AGM(1)
250	300	4.7	8x11.5	15	135	10.150	33.5	ESL475M250AGM(1)
250	300	5.6	8x11.5	15	150	9.000	38.0	ESL565M250AGM(1)
250	300	6.8	8x11.5	15	160	6.700	44.0	ESL685M250AGM(1)
250	300	8.2	8x12	15	170	3.650	51.0	ESL825M250AG9(1)
250	300	10	10x12.5	15	250	3.650	60.0	ESL106M250AH9(1)
250	300	10	8x16	15	250	3.650	60.0	ESL106M250AG8(1)
250	300	15	10x16	15	390	3.240	85.0	ESL156M250AH8(1)
250	300	15	8x20	15	380	3.240	85.0	ESL156M250AG6(1)
250	300	18	10x16	15	410	3.240	100.0	ESL186M250AH8(1)
250	300	22	10x20	15	475	3.240	120.0	ESL226M250AH4(1)
250	300	33	12.5x20	15	570	1.380	175.0	ESL336M250AK5(1)
250	300	33	8x50	15	570	1.380	175.0	ESL336M250AGG(1)
250	300	47	12.5x25	15	650	1.380	245.0	ESL476M250AK1(1)
250	300	56	12.5x30	15	750	1.250	290.0	ESL566M250AK2(1)
250	300	68	10x50	15	870	1.250	350.0	ESL686M250AHE(1)
250	300	68	12.5x30	15	870	1.250	350.0	ESL686M250AK2(1)
250	300	82	16x30	15	910	1.150	420.0	ESL826M250AM9AA
250	300	100	12.5x50	15	960	1.180	510.0	ESL107M250AKB(1)
250	300	100	16x30	15	960	1.180	510.0	ESL107M250AM9AA
250	300	120	18x30	15	1210	1.020	610.0	ESL127M250AN8AA
250	300	150	18x30	15	1400	0.980	760.0	ESL157M250AN8AA
250	300	180	18x35	15	1540	0.740	910.0	ESL187M250ANAAA
250	300	220	18x40	15	1620	0.610	1110.0	ESL227M250AN3AA
350	400	1	6.3x11	20	55	21.500	17.0	ESL105M350AE3(1)
350	400	1.2	6.3x11	20	55	21.500	18.4	ESL125M350AE3(1)
350	400	1.5	6.3x11	20	60	21.500	20.5	ESL155M350AE3(1)
350	400	1.8	6.3x11	20	65	21.500	22.6	ESL185M350AE3(1)
VDC	VDC Surge	Rated Capacitance	Case Size	DF	RC	ESR	LC	Part Number

(1) Insert packaging code. See Ordering Options Table for available options.

* When capacitance exceeds 1,000 µF, the DF value (%) is increased by 2% for every additional 1,000 µF.

Table 1 – Ratings & Part Number Reference cont.

VDC	VDC Surge Voltage	Rated Capacitance 120 Hz 20°C (µF)	Case Size D x L (mm)	DF 120 Hz 20°C (tan δ %)*	RC 100 kHz 105°C (mA)	ESR 100 kHz 20°C (Ω)	LC 20°C 2 Minutes (µA)	Part Number
350	400	2.2	6.3x11	20	70	21.500	25.4	ESL225M350AE3(1)
350	400	2.7	8x11.5	20	85	15.710	28.9	ESL275M350AGM(1)
350	400	3.3	8x11.5	20	95	15.720	33.1	ESL335M350AGM(1)
350	400	3.9	8x11.5	20	100	15.720	37.3	ESL395M350AGM(1)
350	400	4.7	8x11.5	20	130	15.720	42.9	ESL475M350AGM(1)
350	400	5.6	10x12.5	20	155	10.510	49.2	ESL565M350AH9(1)
350	400	5.6	8x16	20	155	10.510	49.2	ESL565M350AG8(1)
350	400	6.8	10x12.5	20	170	10.510	57.6	ESL685M350AH9(1)
350	400	8.2	10x16	20	240	7.500	67.4	ESL825M350AH8(1)
350	400	8.2	8x20	20	240	7.500	67.4	ESL825M350AG6(1)
350	400	10	10x16	20	250	7.500	80.0	ESL106M350AH8(1)
350	400	15	10x25	20	340	6.200	115.0	ESL156M350AH5(1)
350	400	15	12.5x15	20	340	6.200	115.0	ESL156M350AK7(1)
350	400	18	10x25	20	430	6.200	136.0	ESL186M350AH5(1)
350	400	18	12.5x20	20	430	3.100	136.0	ESL186M350AK5(1)
350	400	22	12.5x20	20	475	3.100	164.0	ESL226M350AK5(1)
350	400	22	8x50	20	475	3.100	164.0	ESL226M350AGG(1)
350	400	33	10x50	20	570	2.250	241.0	ESL336M350AHE(1)
350	400	33	12.5x25	20	570	2.250	241.0	ESL336M350AK1(1)
350	400	47	16x25	20	800	2.250	339.0	ESL476M350AM7AA
350	400	56	16x30	20	840	2.020	402.0	ESL566M350AM9AA
350	400	68	12.5x50	20	880	1.380	486.0	ESL686M350AKB(1)
350	400	68	18x25	20	880	1.380	486.0	ESL686M350AN5AA
350	400	82	18x30	20	940	1.380	584.0	ESL826M350AN8AA
350	400	100	18x35	20	1120	1.250	710.0	ESL107M350ANAAA
350	400	120	18x35	20	1200	1.250	850.0	ESL127M350ANAAA
400	450	1	6.3x11	20	65	25.000	18.0	ESL105M400AE3(1)
400	450	1.2	6.3x11	20	70	25.000	19.6	ESL125M400AE3(1)
400	450	1.5	6.3x11	20	75	25.000	22.0	ESL155M400AE3(1)
400	450	1.8	6.3x11	20	85	25.000	24.4	ESL185M400AE3(1)
400	450	2.2	8x11.5	20	90	20.000	27.6	ESL225M400AGM(1)
400	450	2.7	8x11.5	20	95	15.720	31.6	ESL275M400AGM(1)
400	450	3.3	8x11.5	20	100	15.720	36.4	ESL335M400AGM(1)
400	450	3.9	8x11.5	20	105	15.720	41.2	ESL395M400AGM(1)
400	450	4.7	8x11.5	20	110	12.000	47.6	ESL475M400AGM(1)
400	450	4.7	8x16	20	115	12.000	47.6	ESL475M400AG8(1)
400	450	5.6	10x12.5	20	180	10.500	54.8	ESL565M400AH9(1)
400	450	5.6	8x16	20	160	10.510	54.8	ESL565M400AG8(1)
400	450	6.8	10x16	20	220	8.700	64.4	ESL685M400AH8(1)
400	450	6.8	8x20	20	180	8.700	64.4	ESL685M400AG6(1)
400	450	8.2	10x16	20	252	7.500	75.6	ESL825M400AH8(1)
400	450	10	10x20	20	288	4.900	90.0	ESL106M400AH4(1)
400	450	15	12.5x20	20	400	4.200	130.0	ESL156M400AK5(1)
400	450	18	12.5x20	20	470	4.200	154.0	ESL186M400AK5(1)
400	450	22	12.5x25	20	475	2.250	186.0	ESL226M400AK1(1)
400	450	22	8x50	20	475	2.250	186.0	ESL226M400AGG(1)
400	450	33	10x50	20	610	1.700	274.0	ESL336M400AHE(1)
400	450	33	16x25	20	610	1.700	274.0	ESL336M400AM7AA
400	450	47	18x25	20	795	1.700	386.0	ESL476M400AN5AA
400	450	56	12.5x50	20	820	1.700	458.0	ESL566M400AKB(1)
400	450	56	16x30	20	820	1.700	458.0	ESL566M400AM9AA
400	450	68	18x30	20	910	1.380	554.0	ESL686M400AN8AA
400	450	82	16x40	20	980	1.250	666.0	ESL826M400AM4AA
400	450	82	18x35	20	980	1.250	666.0	ESL826M400ANAAA
400	450	100	18x40	20	1100	0.970	810.0	ESL107M400AN3AA
450	500	1	6.3x11	20	50	33.000	19.0	ESL105M450AE3(1)
VDC	VDC Surge	Rated Capacitance	Case Size	DF	RC	ESR	LC	Part Number

(1) Insert packaging code. See Ordering Options Table for available options.

* When capacitance exceeds 1,000 µF, the DF value (%) is increased by 2% for every additional 1,000 µF.

Table 1 – Ratings & Part Number Reference cont.

VDC	VDC Surge Voltage	Rated Capacitance 120 Hz 20°C (µF)	Case Size D x L (mm)	DF 120 Hz 20°C (tan δ %)*	RC 100 kHz 105°C (mA)	ESR 100 kHz 20°C (Ω)	LC 20°C 2 Minutes (µA)	Part Number
450	500	1.2	6.3x11	20	55	25.000	20.8	ESL125M450AE3(1)
450	500	1.5	8x11.5	20	80	25.000	23.5	ESL155M450AGM(1)
450	500	1.8	8x11.5	20	85	20.000	26.2	ESL185M450AGM(1)
450	500	2.2	8x16	20	95	15.720	29.8	ESL225M450AG8(1)
450	500	2.7	8x16	20	100	15.720	34.3	ESL275M450AG8(1)
450	500	3.3	8x16	20	110	15.720	39.7	ESL335M450AG8(1)
450	500	3.9	8x16	20	120	15.720	45.1	ESL395M450AG8(1)
450	500	4.7	10x16	20	150	10.510	52.3	ESL475M450AH8(1)
450	500	4.7	8x20	20	150	10.510	52.3	ESL475M450AG6(1)
450	500	5.6	10x16	20	180	7.500	60.4	ESL565M450AH8(1)
450	500	5.6	8x20	20	180	7.500	60.4	ESL565M450AG6(1)
450	500	6.8	10x16	20	220	7.500	71.2	ESL685M450AH8(1)
450	500	8.2	10x20	20	265	6.200	83.8	ESL825M450AH4(1)
450	500	10	10x25	20	305	6.200	100.0	ESL106M450AH5(1)
450	500	10	12.5x20	20	305	5.200	100.0	ESL106M450AK5(1)
450	500	15	12.5x20	20	400	5.200	145.0	ESL156M450AK5(1)
450	500	15	8x50	20	400	5.200	145.0	ESL156M450AGG(1)
450	500	18	12.5x25	20	470	3.600	172.0	ESL186M450AK1(1)
450	500	22	10x40	20	550	2.020	208.0	ESL226M450AHB(1)
450	500	22	16x20	20	550	2.020	208.0	ESL226M450AM5AA
450	500	33	10x50	20	665	1.820	307.0	ESL336M450AHE(1)
450	500	33	16x25	20	665	1.820	307.0	ESL336M450AM7AA
450	500	47	12.5x50	20	730	1.380	433.0	ESL476M450AKB(1)
450	500	47	16x35	20	730	1.380	433.0	ESL476M450AMPAA
450	500	56	16x35	20	750	1.380	514.0	ESL566M450AMPAA
450	500	68	18x35	20	970	1.250	622.0	ESL686M450ANAAA
450	500	82	18x40	20	1030	0.970	748.0	ESL826M450AN3AA
VDC	VDC Surge	Rated Capacitance	Case Size	DF	RC	ESR	LC	Part Number

(1) Insert packaging code. See Ordering Options Table for available options.

* When capacitance exceeds 1,000 µF, the DF value (%) is increased by 2% for every additional 1,000 µF.

Mounting Positions (Safety Vent)

In operation, electrolytic capacitors will always conduct a leakage current, which causes electrolysis. The oxygen produced by electrolysis will regenerate the dielectric layer but, at the same time, the hydrogen released may cause the internal pressure of the capacitor to increase. The overpressure vent, or safety vent, ensures that the gas can escape when the pressure reaches a certain value. All mounting positions must allow the safety vent to work properly.

Installing

- As a general principle, lower-use temperatures result in a longer, useful life of the capacitor. For this reason, it should be ensured that electrolytic capacitors are placed away from heat-emitting components. Adequate space should be allowed between components for cooling air to circulate, particularly when high ripple current loads are applied. In any case, the maximum category temperature must not be exceeded.
- Do not deform the case of the capacitors or use capacitors with a deformed case.
- Verify that the connections of the capacitors are able to insert on the board without excessive mechanical force.
- If the capacitors require mounting through additional means, the recommended mounting accessories shall be used.
- Verify the correct polarization of the capacitor on the board.
- Verify that the space around the pressure relief device is according to the following guideline:

Case Diameter	Space Around Safety Vent
≤ 16 mm	> 2 mm
> 16 to ≤ 40 mm	> 3 mm
> 40 mm	> 5 mm

It is recommended that capacitors always be mounted with the safety device uppermost or in the upper part of the capacitor.

- If the capacitors are stored for a long time, the leakage current must be verified. If the leakage current is superior to the value listed in this catalog, the capacitors must be reformed. In this case, they can be reformed by application of the rated voltage through a series resistor approximately 1 kΩ for capacitors with $V_R \leq 160$ V (5 W resistor) and 10 kΩ for the other rated voltages.
- In the case of capacitors connected in a series, a suitable voltage sharing must be used.
 In the case of balancing resistors, the approximate resistance value can be calculated as: $R = 60/C$.

KEMET recommends, nevertheless, to ensure that the voltage across each capacitor does not exceed its rated voltage.

Application & Operation Guidelines

Electrical Ratings: Capacitance (ESC)



Simplified equivalent circuit diagram of an electrolytic capacitor

The capacitive component of the equivalent series circuit, (equivalent series capacitance - ESC), is determined by applying an alternate voltage of ≤ 0.5 V at a frequency of 120 or 100 Hz and 20°C (IEC 384-1, 384-4).

Temperature Dependence of the Capacitance

Capacitance of an electrolytic capacitor depends upon temperature: with decreasing temperature the viscosity of the electrolyte increases, thereby reducing its conductivity.

Capacitance will decrease if temperature decreases. Furthermore, temperature drifts cause armature dilatation and, therefore, capacitance changes (up to 20% depending on the series considered, from 0 to 80°C). This phenomenon is more evident for electrolytic capacitors than for other types.

Frequency Dependence of the Capacitance

Effective capacitance value is derived from the impedance curve, as long as impedance is still in the range where the capacitance component is dominant.

$$C = \frac{1}{2\pi fZ}$$

C = capacitance (F)
 f = frequency (Hz)
 Z = impedance (Ω)

Dissipation Factor $\tan \delta$ (DF)

Dissipation Factor $\tan \delta$ is the ratio between the active and reactive power for a sinusoidal waveform voltage. It can be thought of as a measurement of the gap between an actual and ideal capacitor.

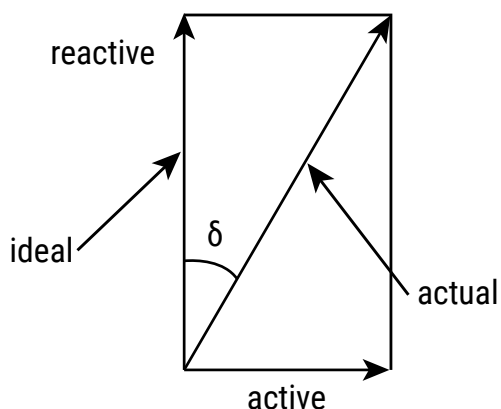

$\tan \delta$ is measured with the same set-up used for the series capacitance ESC.

$\tan \delta = \omega \times \text{ESC} \times \text{ESR}$ where:

ESC = Equivalent series capacitance

ESR = Equivalent series resistance

Equivalent Series Inductance (ESL)

Equivalent series inductance or self inductance results from the terminal configuration and internal design of the capacitor.

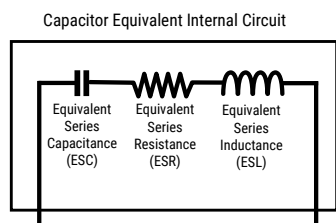

Equivalent Series Resistance (ESR)

Equivalent series resistance is the resistive component of the equivalent series circuit. ESR value depends on frequency and temperature, and is related to the $\tan \delta$ by the following equation:

$$ESR = \frac{\tan \delta}{2\pi f ESC}$$

ESR = Equivalent series resistance (Ω)
 $\tan \delta$ = Dissipation factor
 ESC = Equivalent series capacitance (F)
 f = Frequency (Hz)

Tolerance limits of the rated capacitance must be taken into account when calculating this value.

Impedance (Z)

Impedance of an electrolytic capacitor results from a circuit formed by the following individual equivalent series components:

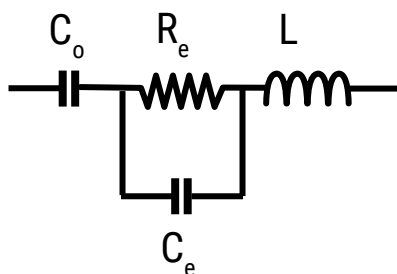

C_o = Aluminum oxide capacitance (surface and thickness of the dielectric.)

R_e = Resistance of electrolyte and paper mixture (other resistances not depending on the frequency are not considered: tabs, plates, etc.)

C_e = Electrolyte soaked paper capacitance.

L = Inductive reactance of the capacitor winding and terminals.

Impedance of an electrolytic capacitor is not a constant quantity that retains its value under all conditions; it changes depending on frequency and temperature.

Impedance as a function of frequency (sinusoidal waveform) for a certain temperature can be represented as follows:

Impedance (Z) cont.

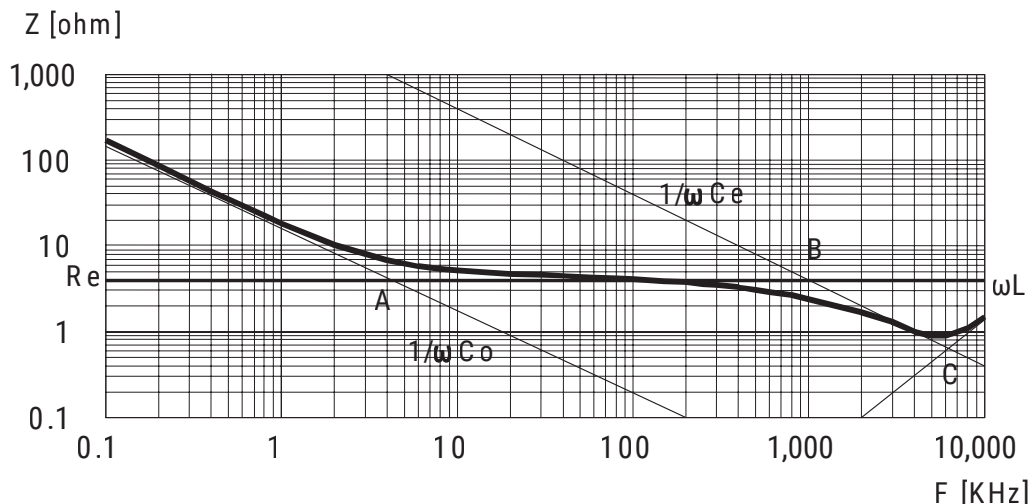

- Capacitive reactance predominates at low frequencies.
- With increasing frequency, capacitive reactance $X_c = 1/\omega C_o$ decreases until it reaches the order of magnitude of electrolyte resistance R_e (A)
- At even higher frequencies, resistance of the electrolyte predominates: $Z = R_e$ (A - B)
- When the capacitor's resonance frequency is reached (ω_o), capacitive and inductive reactance mutually cancel each other $1/\omega C_e = \omega L$, $\omega_o = 1/\text{SQR}(LC_e)$
- Above this frequency, inductive reactance of the winding and its terminals ($X_L = Z = \omega L$) becomes effective and leads to an increase in impedance

Generally speaking, it can be estimated that $C_e \approx 0.01 C_o$.

Impedance as a function of frequency (sinusoidal waveform) for different temperature values can be represented as follows (typical values):

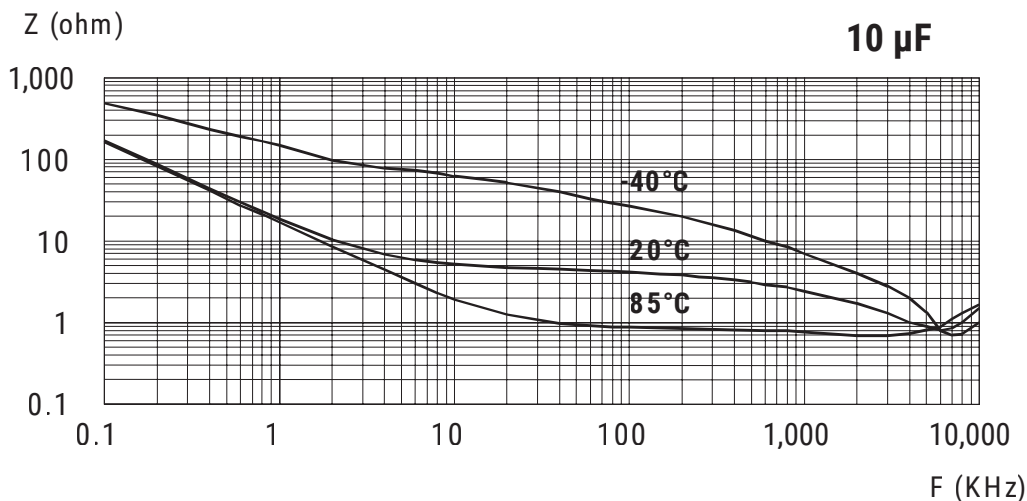

R_e is the most temperature-dependent component of an electrolytic capacitor equivalent circuit. Electrolyte resistivity will decrease if temperature rises.

In order to obtain a low impedance value throughout the temperature range, R_e must be as little as possible. However, R_e values that are too low indicate a very aggressive electrolyte, resulting in a shorter life of the electrolytic capacitor at high temperatures. A compromise must be reached.

Leakage Current (LC)

Due to the aluminum oxide layer that serves as a dielectric, a small current will continue to flow even after a DC voltage has been applied for long periods. This current is called leakage current.

A high leakage current flows after applying voltage to the capacitor then decreases in a few minutes, for example, after prolonged storage without any applied voltage. In the course of continuous operation, the leakage current will decrease and reach an almost constant value.

After a voltage-free storage the oxide layer may deteriorate, especially at a high temperature. Since there are no leakage currents to transport oxygen ions to the anode, the oxide layer is not regenerated. The result is that a higher than normal leakage current will flow when voltage is applied after prolonged storage.

As the oxide layer is regenerated in use, the leakage current will gradually decrease to its normal level. The relationship between the leakage current and voltage applied at constant temperature can be shown schematically as follows:

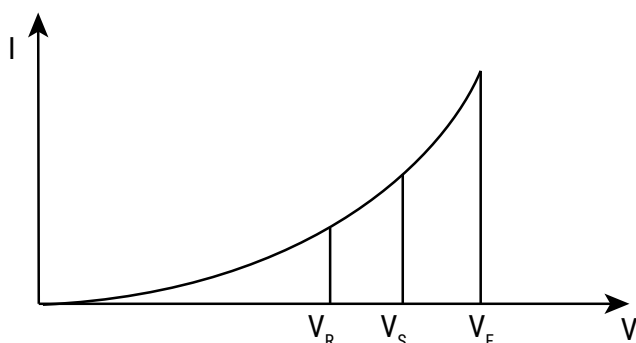

Where:

V_F = Forming voltage

If this level is exceeded, a large quantity of heat and gas will be generated and the capacitor could be damaged.

V_R = Rated voltage

This level represents the top of the linear part of the curve.

V_S = Surge voltage

This lies between V_R and V_F . The capacitor can be subjected to V_S for short periods only.

Electrolytic capacitors are subjected to a reforming process before acceptance testing. The purpose of this preconditioning is to ensure that the same initial conditions are maintained when comparing different products.

Ripple Current (RC)

The maximum ripple current value depends on:

- Ambient temperature
- Surface area of the capacitor (heat dissipation area)
- tan δ or ESR
- Frequency

The capacitor's life depends on the thermal stress.

Frequency Dependence of the Ripple Current

ESR and, thus, the $\tan \delta$ depend on the frequency of the applied voltage. This indicates that the allowed ripple current is also a function of the frequency.

Temperature Dependence of the Ripple Current

The data sheet specifies maximum ripple current at the upper category temperature for each capacitor.

Expected Life Calculation

Expected life depends on operating temperature according to the following formula: $L = L_0 \times 2^{(T_0-T)/10}$

Where:

- L: Expected life
- L_0 : Load life at a maximum permissible operating temperature
- T: Actual operating temperature
- T_0 : Maximum permissible operating temperature

This formula is applicable between 40°C and T_0 .

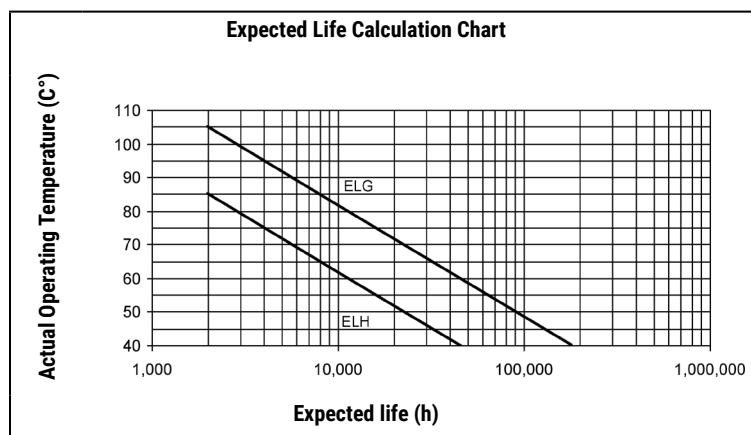

Packaging Quantities

Size Code	Diameter (mm)	Length (mm)	Bulk		Auto-insertion	
			Standard Leads	Cut Leads	Ammo	Tape & Reel
C3	5.0	11.0	10,000	15,000	2,000	-
E3	6.3	11.0	10,000	15,000	2,000	-
GM	8.0	11.5	6,000	8,000	1,000	-
G9	8.0	12.0	6,000	8,000	1,000	-
G8	8.0	16.0	5,000	5,000	1,000	-
G6	8.0	20.0	4,000	4,000	1,000	-
GG	8.0	50.0	2,400	2,400	-	-
H9	10.0	12.5	4,000	4,000	700	-
H8	10.0	16.0	3,000	4,000	700	-
H4	10.0	20.0	2,400	3,000	700	-
H5	10.0	25.0	2,400	2,400	500	-
HB	10.0	40.0	2,100	2,100	-	-
HE	10.0	50.0	2,100	2,100	-	-
K7	12.5	15.0	2,000	2,000	500	-
K5	12.5	20.0	2,000	2,000	500	-
K1	12.5	25.0	2,000	2,000	500	-
K2	12.5	30.0	2,000	2,000	500	-
K3	12.5	35.0	2,000	2,000	500	-
K4	12.5	40.0	2,000	2,000	500	-
KB	12.5	50.0	1,200	1,200	-	-
M5	16.0	20.0	1,000	500	-	-
M7	16.0	25.0	1,000	500	-	-
M9	16.0	30.0	800	500	-	-
MP	16.0	35.0	600	500	-	-
M4	16.0	40.0	600	500	-	-
N5	18.0	25.0	800	500	-	-
N8	18.0	30.0	800	500	-	-
NA	18.0	35.0	500	500	-	-
N3	18.0	40.0	500	500	-	-

Marking

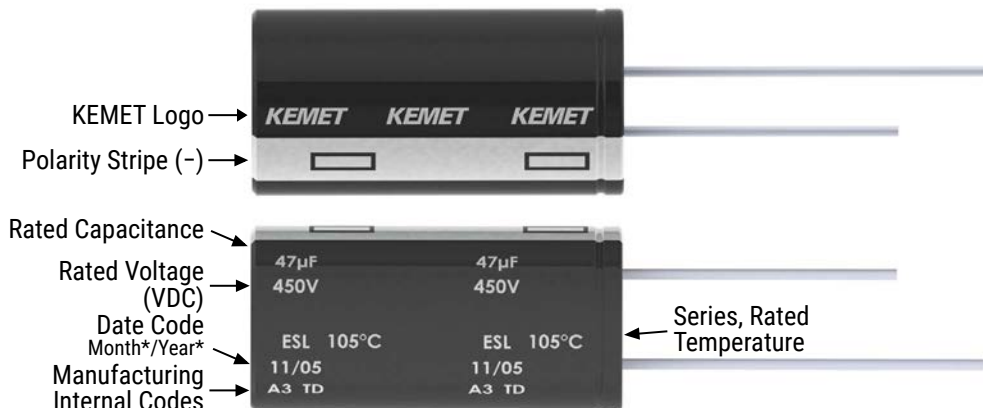

*Y = Year

Code	01	02	03	04	05	06	07	08	09
Year	2011	2012	2013	2014	2015	2016	2017	2018	2019

*M = Month

Code	01	02	03	04	05	06	07	08	09	10	11	12
Month	1	2	3	4	5	6	7	8	9	10	11	12

Construction

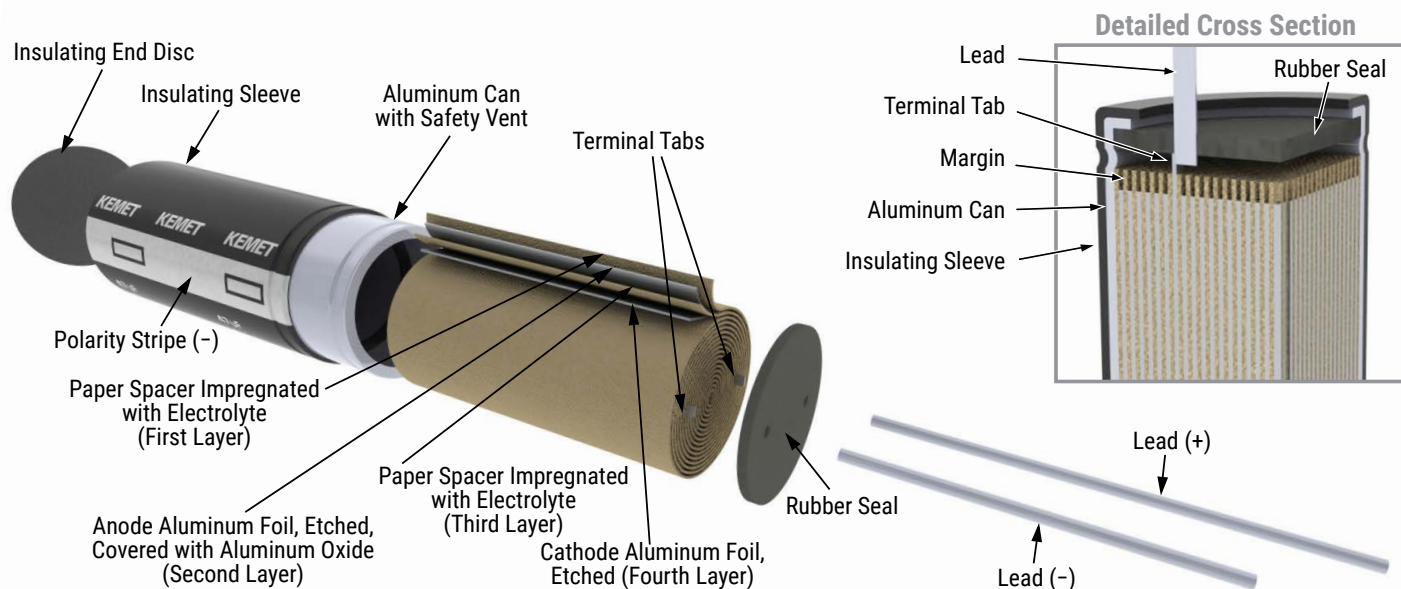

Lead Taping & Packaging

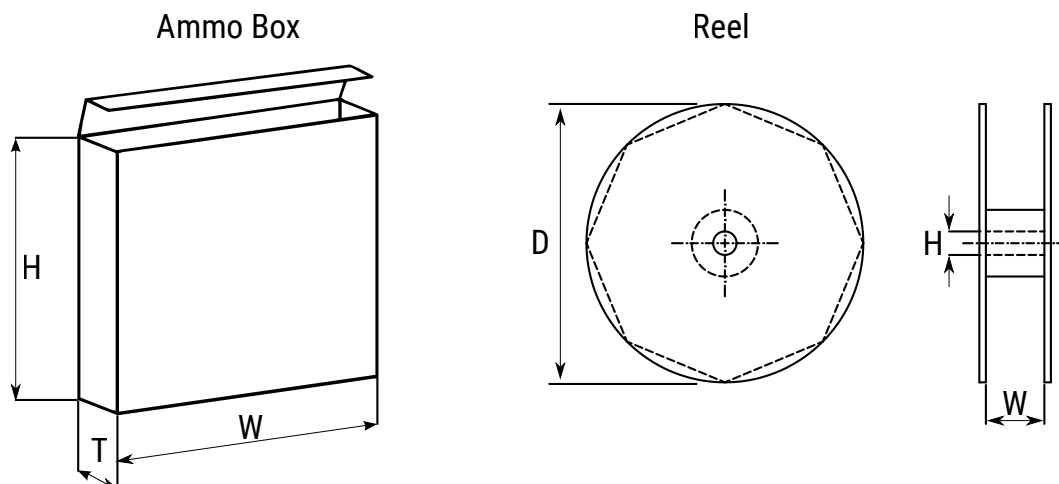

Diameter	Length	Ammo			Reel		
		H	W	T	D	H	W
			Maximum	Maximum	±2	±0.5	+1/-0.1
4	All	230	340	42	350	30	50
5	≤ 7	230	340	42			
5	11	230	340	48			
6.3	≤ 7	275	340	42			
6.3	11	270	340	48			
8	≤ 7	235	340	45			
8	11	235	340	48			
8	>11 ≤ 20	240	340	57			
10	≤ 13	250	340	52			
10	>13 ≤ 20	256	340	57			
10	>20	250	340	60			
12	All	270	340	57			
13	All	285	340	62			

Construction Data

The manufacturing process begins with the anode foil being electrochemically etched to increase the surface area and then “formed” to produce the aluminum oxide layer. Both the anode and cathode foils are then interleaved with absorbent paper and wound into a cylinder. During the winding process, aluminum tabs are attached to each foil to provide the electrical contact.

The deck, complete with terminals, is attached to the tabs and then folded down to rest on top of the winding. The complete winding is impregnated with electrolyte before being housed in a suitable container, usually an aluminum can, and sealed. Throughout the process, all materials inside the housing must be maintained at the highest purity and be compatible with the electrolyte.

Each capacitor is aged and tested before being sleeved and packed. The purpose of aging is to repair any damage in the oxide layer and thus reduce the leakage current to a very low level. Aging is normally carried out at the rated temperature of the capacitor and is accomplished by applying voltage to the device while carefully controlling the supply current. The process may take several hours to complete.

Damage to the oxide layer can occur due to variety of reasons:

- Slitting of the anode foil after forming
- Attaching the tabs to the anode foil
- Minor mechanical damage caused during winding

A sample from each batch is taken by the quality department after completion of the production process. This sample size is controlled by the use of recognized sampling tables defined in BS 6001.

The following tests are applied and may be varied at the request of the customer. In this case the batch, or special procedure, will determine the course of action.

Electrical:

- Leakage current
- Capacitance
- ESR
- Impedance
- Tan Delta

Mechanical/Visual:

- Overall dimensions
- Torque test of mounting stud
- Print detail
- Box labels
- Packaging, including packed quantity

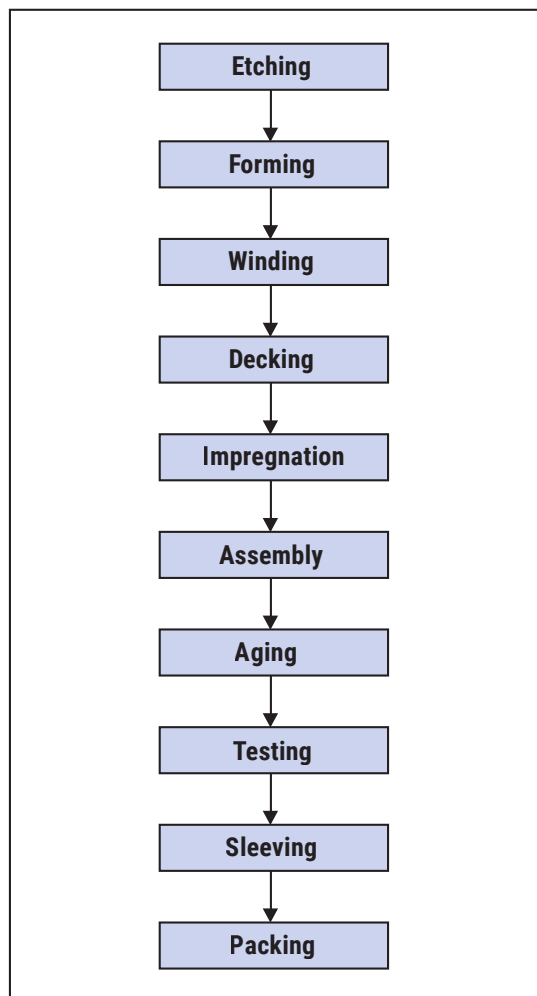
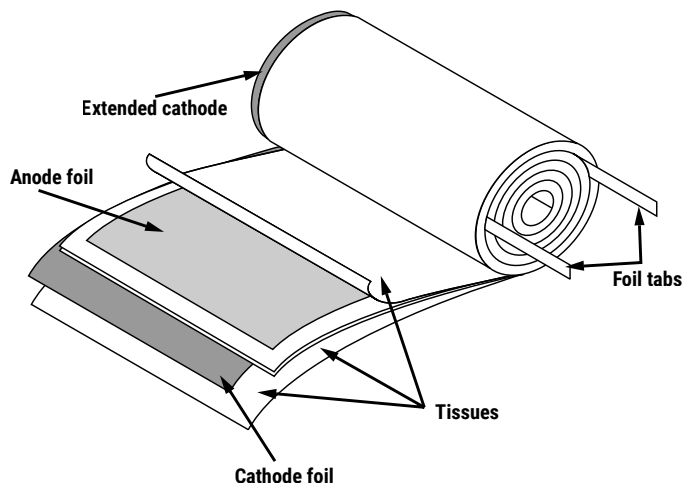

KEMET Electronics Corporation Sales Offices

For a complete list of our global sales offices, please visit www.kemet.com/sales.

Disclaimer

All product specifications, statements, information and data (collectively, the "Information") in this datasheet are subject to change. The customer is responsible for checking and verifying the extent to which the Information contained in this publication is applicable to an order at the time the order is placed. All Information given herein is believed to be accurate and reliable, but it is presented without guarantee, warranty, or responsibility of any kind, expressed or implied.

Statements of suitability for certain applications are based on KEMET Electronics Corporation's ("KEMET") knowledge of typical operating conditions for such applications, but are not intended to constitute – and KEMET specifically disclaims – any warranty concerning suitability for a specific customer application or use. The Information is intended for use only by customers who have the requisite experience and capability to determine the correct products for their application. Any technical advice inferred from this Information or otherwise provided by KEMET with reference to the use of KEMET's products is given gratis, and KEMET assumes no obligation or liability for the advice given or results obtained.

Although KEMET designs and manufactures its products to the most stringent quality and safety standards, given the current state of the art, isolated component failures may still occur. Accordingly, customer applications which require a high degree of reliability or safety should employ suitable designs or other safeguards (such as installation of protective circuitry or redundancies) in order to ensure that the failure of an electrical component does not result in a risk of personal injury or property damage.

Although all product-related warnings, cautions and notes must be observed, the customer should not assume that all safety measures are indicated or that other measures may not be required.

KEMET is a registered trademark of KEMET Electronics Corporation.