

ESG, Aluminum Electrolytic, 105C LowZ, 10 uF, 20%, 450 VDC, -25/+105C, Lead Spacing = 5mm

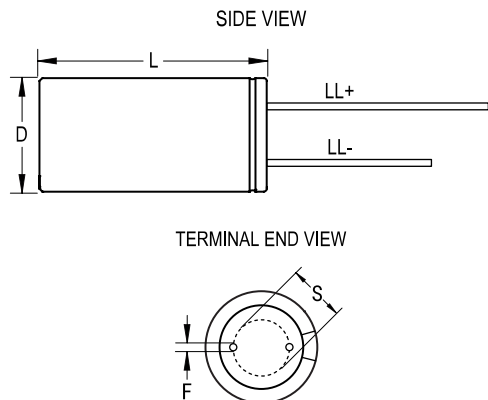

General Information	
Supplier:	KEMET
Series:	ESG
Dielectric:	Aluminum Electrolytic
Description:	Long Life Single Ended Aluminum Electrolytic
Features:	Long Life
RoHS:	Yes
Lead:	Wire Leads

Dimensions	
D	13mm +/-0.5mm
L	20mm +2mm
S	5mm +/-0.5mm
LL Negative	15mm MIN
LL Positive	20mm MIN
F	0.6mm NOM

Specifications	
Capacitance:	10 uF
Capacitance Tolerance:	20%
Voltage DC:	450 VDC, 500 VDC (Surge)
Temperature Range:	-25/+105C
Rated Temperature:	105C
Life:	5000 Hrs
Dissipation Factor:	24.00% 120Hz 20c
Ripple Current:	110 mAmps (120kHz 105C)
Leakage Current:	280 uA (2min 20C)
Impedance Ratio at -25C:	6

Packaging Specifications	
Packaging:	Bulk, Bag
Packaging Quantity:	2000