

DO NOT SCALE FROM THIS PRINT

DESIGNED AND DIMENSIONED IN MILLIMETERS[INCHES]  
ALL DIMENSIONS REFERENCE

ERF6-XX-XX.X-X-DV-A-XX-K-XR

No OF POSITIONS  
-10, -20, -30,  
-40, -50, -60  
(PER ROW)

LEAD STYLE  
-03.5: 3.5MM

PLATING SPECIFICATION  
-L: 10µ" SELECTIVE GOLD  
IN CONTACT AREA,  
MATTE TIN ON TAIL  
(USE C-435-XX.X-L)  
-S: 30µ" SELECTIVE GOLD  
IN CONTACT AREA,  
MATTE TIN ON TAIL  
(USE C-435-XX.X-S)

TAPE & REEL (SEE NOTES 4 & 6)  
-TR: TAPE & REEL  
-FR: FULL REEL QTY TAPE & REEL

-K: KAPTON  
(SEE NOTE 3)

OPTION  
\*-WT: WELD TAB  
(SEE FIG 3, SHT 2)

-A: ALIGNMENT PIN

ROW SPECIFICATION  
-DV: DOUBLE VERTICAL

(\* = NOT RELEASED)

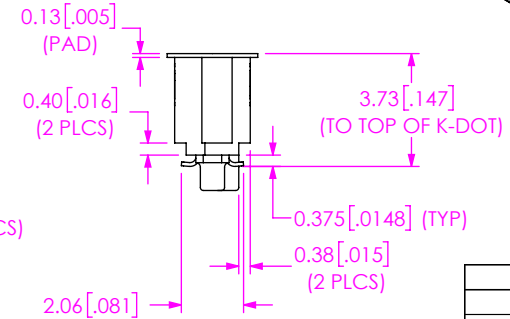
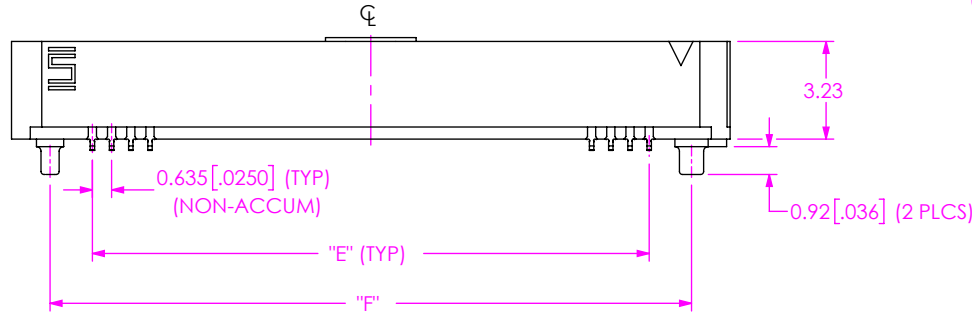
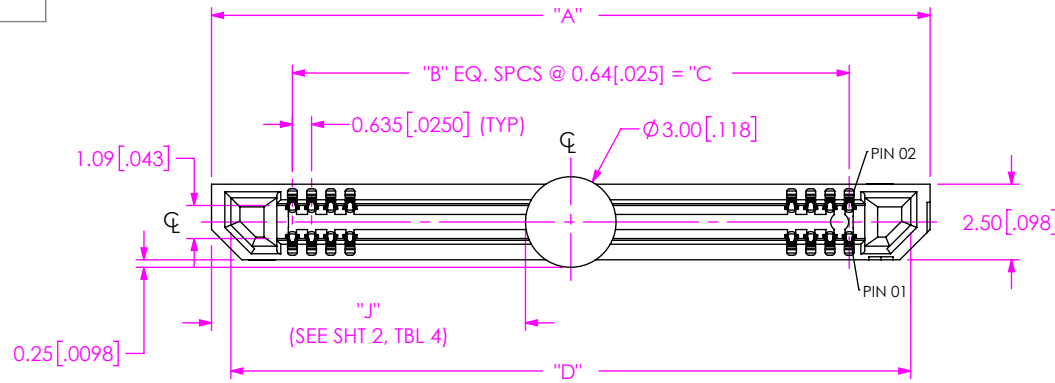
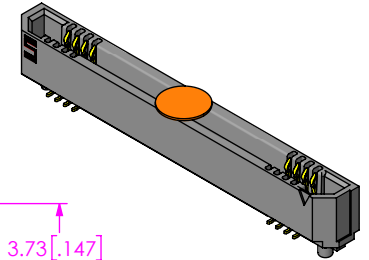

ERF6 LEAD STYLE	ERM6 LEAD STYLE
-03.5	5.00 [0.197]

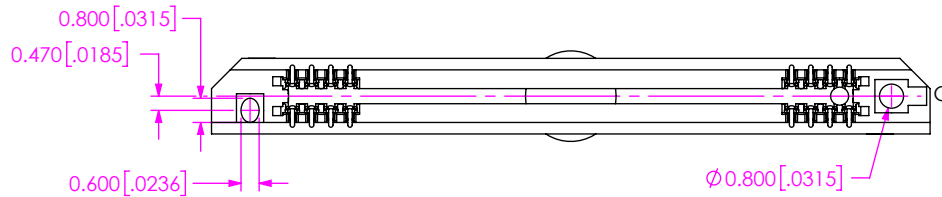

FIG 1  
ERF6-30-03.5-X-DV-A-K-XR SHOWN  
(SOME CENTER FEATURES REMOVED FOR CLARITY)

No OF POS PER ROW	"A"	"B"	"C"	"D"	"E"	"F"
-10	11.07 [0.436]	9	5.715 [0.2250]	9.785 [0.3852]	5.72 [0.225]	8.52 [0.335]
-20	17.42 [0.686]	19	12.065 [0.4750]	16.135 [0.6352]	12.07 [0.475]	14.87 [0.585]
-30	23.77 [0.936]	29	18.415 [0.7250]	22.485 [0.8852]	18.42 [0.725]	21.22 [0.835]
-40	30.12 [1.186]	39	24.765 [0.9750]	28.835 [1.1352]	24.77 [0.975]	27.57 [1.085]
-50	36.47 [1.436]	49	31.115 [1.2250]	35.185 [1.3852]	31.12 [1.225]	33.92 [1.335]
-60	42.82 [1.686]	59	37.465 [1.4750]	41.535 [1.6352]	37.47 [1.475]	40.27 [1.585]

NOTES:

- NOTE DELETED.
- NOTE DELETED.
- K-DOT PROVIDED AS STANDARD.
- ORDERS WILL BE PACKAGED ACCORDING TO THE SAMTEC PACKAGING EFFICIENCY STANDARDS (SPES) FOUND ON WWW.SAMTEC.COM
- NOTE DELETED.
- ATTACH LABEL TO EACH REEL.

PROPRIETARY NOTE  
THIS DOCUMENT CONTAINS CONFIDENTIAL AND PROPRIETARY INFORMATION AND ALL DESIGN, MANUFACTURING, REPRODUCTION, USE, PATENT RIGHTS AND SALES RIGHTS ARE EXPRESSLY RESERVED BY SAMTEC, INC. THIS DOCUMENT SHALL NOT BE DISCLOSED, IN WHOLE OR PART, TO ANY UNAUTHORIZED PERSON OR ENTITY NOR REPRODUCED, TRANSFERRED OR INCORPORATED IN ANY OTHER PROJECT IN ANY MANNER WITHOUT THE EXPRESS WRITTEN CONSENT OF SAMTEC, INC.



520 PARK EAST BLVD, NEW ALBANY, IN 47150  
PHONE: 812-944-6733 FAX: 812-948-5047  
e-Mail info@SAMTEC.com code 55322

DO NOT SCALE DRAWING  
SHEET SCALE: 4:1

MATERIAL:  
INSULATOR: LCP, COLOR BLACK  
CONTACT: COPPER ALLOY

DESCRIPTION:  
ERF6 ASSEMBLY

DWG. NO.  
ERF6-XX-XX.X-X-DV-A-XX-K-XR

BY: JERRY SU 09/28/2017 SHEET 1 OF 2

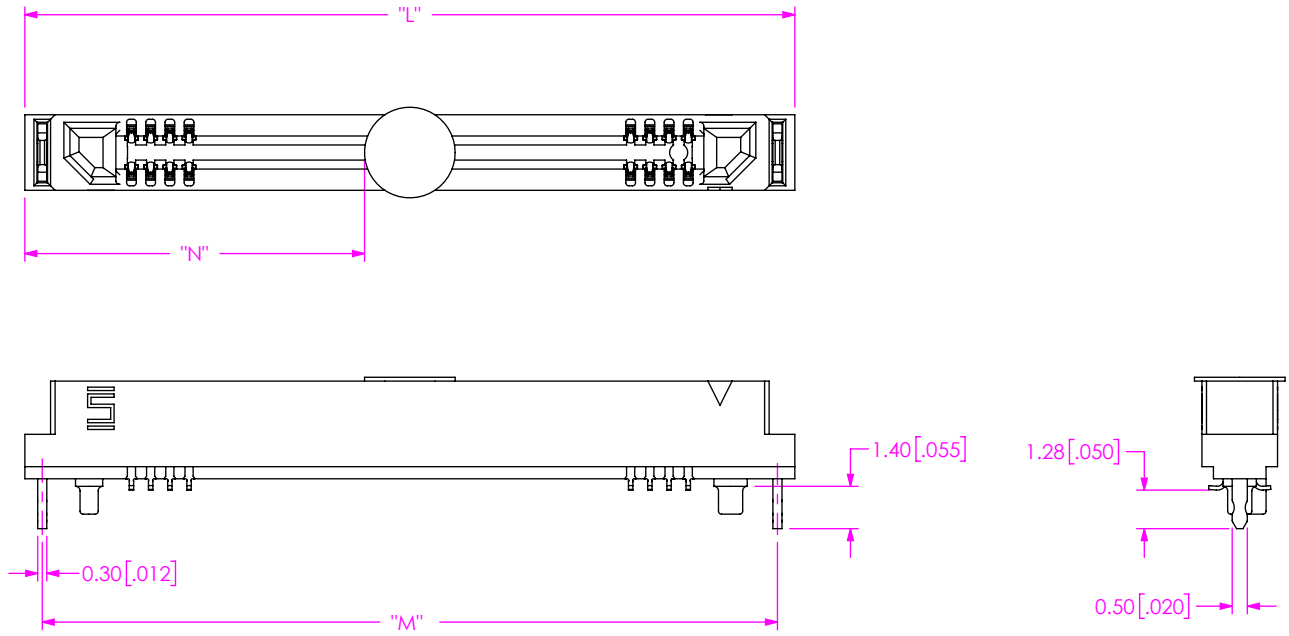



FIG 2  
 ERF6-30-03.5-X-DV-A-WT-K-XR SHOWN  
 (DIFFERENT AS SHOWN, OTHERWISE SAME AS FIG 1)  
 (SOME CENTER FEATURES REMOVED FOR CLARITY)

TABLE 4				
No OF POS PER ROW	"J"	"L"	"M"	"N"
-10	4.03 [0.159]	12.77 [0.503]	11.62 [0.457]	4.88 [0.192]
-20	7.21 [0.284]	19.12 [0.753]	17.97 [0.707]	8.06 [0.317]
-30	10.38 [0.409]	25.47 [1.003]	24.32 [0.957]	11.23 [0.442]
-40	13.56 [0.534]	31.82 [1.253]	30.67 [1.207]	14.41 [0.567]
-50	16.73 [0.659]	38.17 [1.503]	37.02 [1.457]	17.58 [0.692]
-60	19.91 [0.784]	44.52 [1.753]	43.37 [1.707]	20.76 [0.817]

<p><b>PROPRIETARY NOTE</b></p> <p>THIS DOCUMENT CONTAINS CONFIDENTIAL AND PROPRIETARY INFORMATION AND ALL DESIGN, MANUFACTURING, REPRODUCTION, USE, PATENT RIGHTS AND SALES RIGHTS ARE EXPRESSLY RESERVED BY SAMTEC, INC. THIS DOCUMENT SHALL NOT BE DISCLOSED, IN WHOLE OR PART, TO ANY UNAUTHORIZED PERSON OR ENTITY NOR REPRODUCED, TRANSFERRED OR INCORPORATED IN ANY OTHER PROJECT IN ANY MANNER WITHOUT THE EXPRESS WRITTEN CONSENT OF SAMTEC, INC.</p>	 <p>520 PARK EAST BLVD. NEW ALBANY, IN 47150                  PHONE: 812-944-6733 FAX: 812-948-5047                  e-Mail info@SAMTEC.com code 55322</p>	
	<p>DO NOT SCALE DRAWING                  SHEET SCALE: 4:1</p>	<p>DESCRIPTION:                  ERF6 ASSEMBLY</p>
	<p>BY: JERRY SU 09/28/2017</p>	<p>DWG. NO.                  ERF6-XX-XX.X-X-DV-A-XX-K-XR</p> <p>SHEET 2 OF 2</p>