

AUTOMOTIVE RELAYS

Twin Relays EN2/EP2 Series

Single Relays EP1/MR301 Series



DESCRIPTION

The EN2, EP2, EPI and MR301 series power relays can meet the requirements of high quality and reliability in automotive electronics applications.

The EN2 and EP2 series are the twin relays which have two units in one package and smaller than conventional two relays. These relays are divided into two types for different usage. One is H bridge type and the other is separate type.

The EN2 series is suitable for heavy load applications (35 A max.). The EP2 series is designed for medium load applications (25 A max.). The EP1 and MR301 series are the 1C contact form relays.

Many of these relays have been used in automotive electronics applications throughout the world.

EN2 Series

FEATURES

- Twin relay for motor and solenoid reversible control
- 30% less relay space than conventional two relays
- Contact switching current of 35 A max.
- High performance and productivity by unique symmetrical structure
- Flux tight housing
- Delivered in stick-tube for automatic insertion machine
- Washable type available

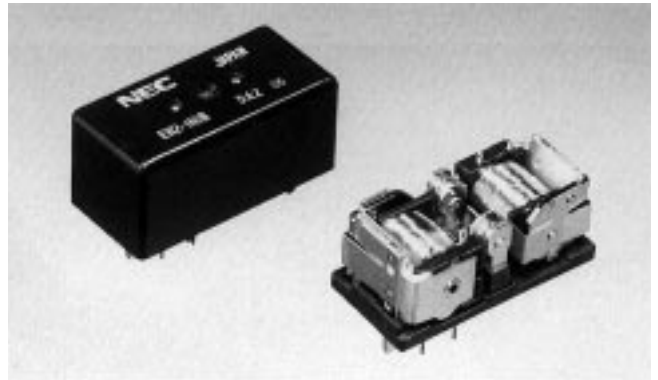

PART NUMBERS AND COIL RATINGS

at 25°C (77°F)

Part Numbers		Nominal Voltage (Vdc)	Coil Resistance ($\Omega \pm 10\%$)	Nominal Current (mA)	Must Operate Voltage (Vdc max.)	Must Release Voltage (Vdc min.)	Nominal Operate Power (W)
H Bridge Type	Separate Type						
EN2-1N1S	EN2-1N1ST	12	125	96.0	6.5	0.6	1.15
EN2-1N2S	EN2-1N2ST	12	125	96.0	7.0	0.6	1.15
EN2-2N3S	EN2-2N3ST	12	180	67.0	7.5	0.6	0.8
EN2-2N4S	EN2-2N4ST	12	180	67.0	8.0	0.6	0.8
EN2-3N4S	EN2-3N4ST	12	250	53.0	8.0	0.9	0.64
EN2-3N5S	EN2-3N5ST	12	250	53.0	8.5	0.9	0.64

■ PART NUMBER SYSTEM

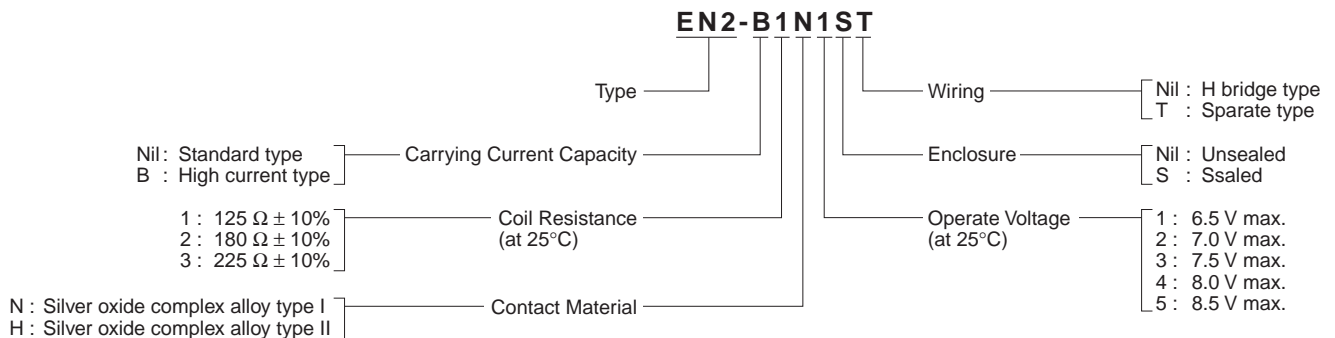

■ **DIMENSIONS** mm (inch)

[H Bridge Type]

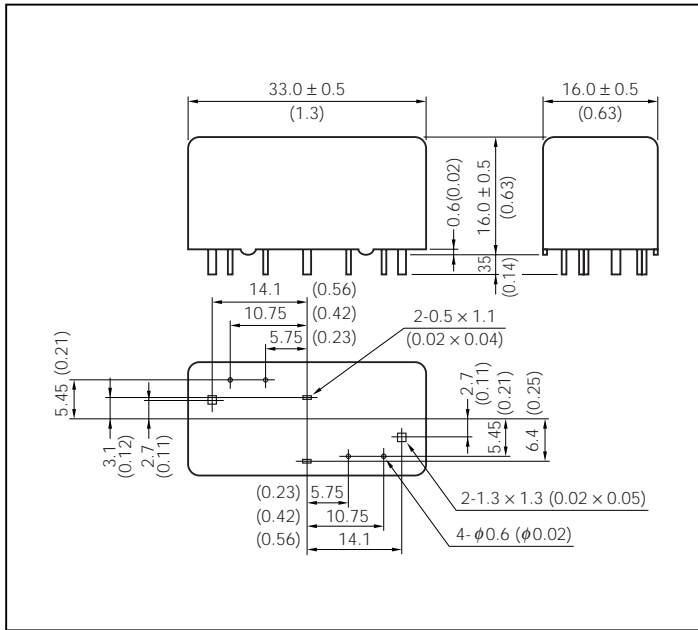

[Separate (T) Type]

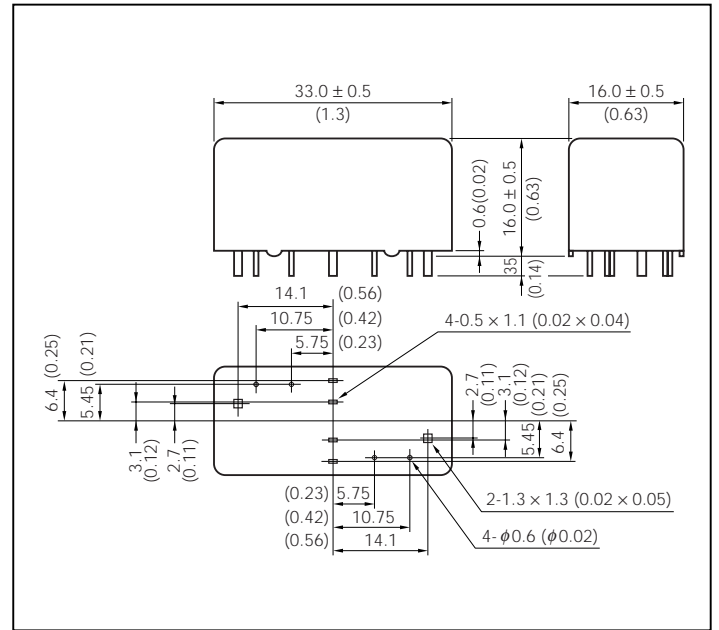

■ **PCB PAD LAYOUT and SCHEMATICS** (bottom view) mm (inch)

[H Bridge Type]

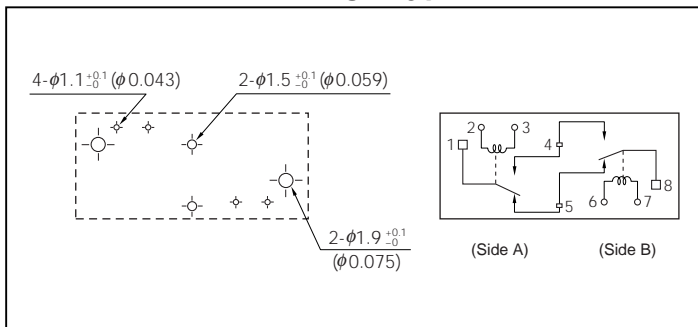

[Separate (T) Type]

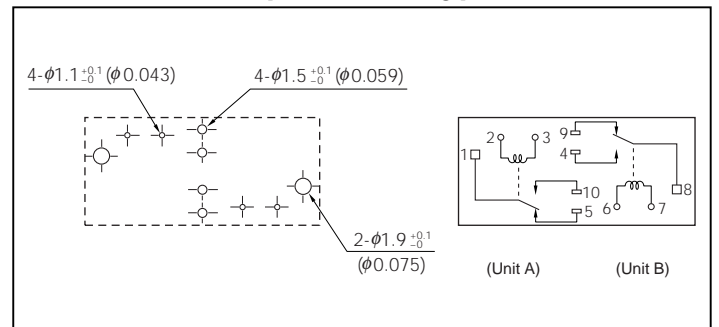

SPECIFICATIONS

at 25°C (77°F)

Items		Specification
Contact Form		1 form C x 2 [H Bridge Type & Separate Type]
Contact Material		Silver oxide complex alloy (Special types available)
Contact Resistance		50 mΩ max. (measured at 7 A) initial
Contact Switching Voltage		30 Vdc max. 5 Vdc min.
Contact Switching Current		35 A max. (at 16 Vdc) 1 A min.
Contact Carrying Current	Standard	25 A max. (2 minutes max.) (at 12 Vdc, 85°C)
	High	35 A max. (2 minutes max.) (at 12 Vdc, 85°C)
Operate Time		Approx. 5 ms max. (at 12 Vdc, excluding bounce) initial
Release Time		Approx. 2 ms max. (at 12 Vdc, excluding bounce) initial, without diode
Nominal Operate Power		0.64 W/0.8 W/1.15 W (at 12 Vdc)
Insulation Resistance		100 MΩ min. (at 500 Vdc) initial
Breakdown Voltage		500 Vdc min. (for 1 minute) initial
Shock Resistance		98 m/s ² [Approx. 10 G] min. (misoperating)
Vibration Resistance		10 to 300 Hz, 43 m/s ² [Approx. 4.4 G] min. (misoperating)
Ambient Temperature		-40°C to +85°C (-40°F to +185°F)
Coil Temperature Rise		50°C/W (contact carrying current 0 A)
Life Expectancy	Mechanical	1 x 10 ⁶ operations
	Electrical	1 x 10 ⁵ operations (at 14 Vdc, Motor Load 25 A/7 A)
Weight		Approx. 18 gr.

EP2 Series

FEATURES

- Twin relay for motor and solenoid reversible control
- 50% less relay space than conventional two relays
- Contact switching current of 25 A max.
- High performance and productivity by unique symmetrical structure
- Flux tight housing
- Delivered in stick-tube for automatic insertion machine
- Washable type available

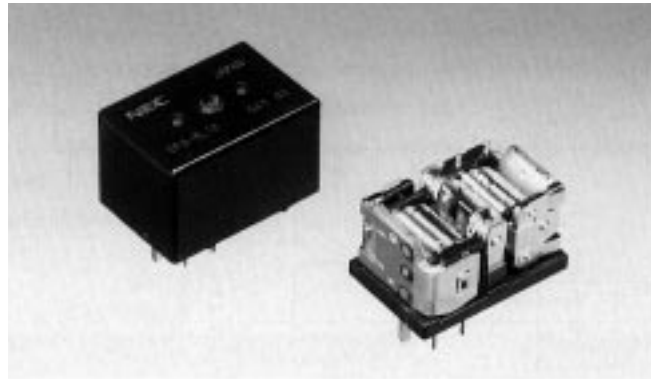

PART NUMBERS AND COIL RATINGS

at 25°C (77°F)

Part Numbers		Nominal Voltage (Vdc)	Coil Resistance ($\Omega \pm 10\%$)	Nominal Current (mA)	Must Operate Voltage (Vdc max.)	Must Release Voltage (Vdc min.)	Nominal Operate Power (W)
H Bridge Type	Separate Type						
EP2-3N1S	EP2-3N1ST	12	225	53.3	6.5	0.9	0.64
EP2-3N2S	EP2-3N2ST	12	225	53.3	7.0	0.9	0.64
EP2-3N3S	EP2-3N3ST	12	225	53.3	7.5	0.9	0.64
EP2-4N3S	EP2-4N3ST	12	300	40.0	7.5	0.9	0.48
EP2-4N4S	EP2-4N4ST	12	300	40.0	8.0	0.9	0.48
EP2-4N5S	EP2-4N5ST	12	300	40.0	8.5	0.9	0.48

■ PART NUMBER SYSTEM

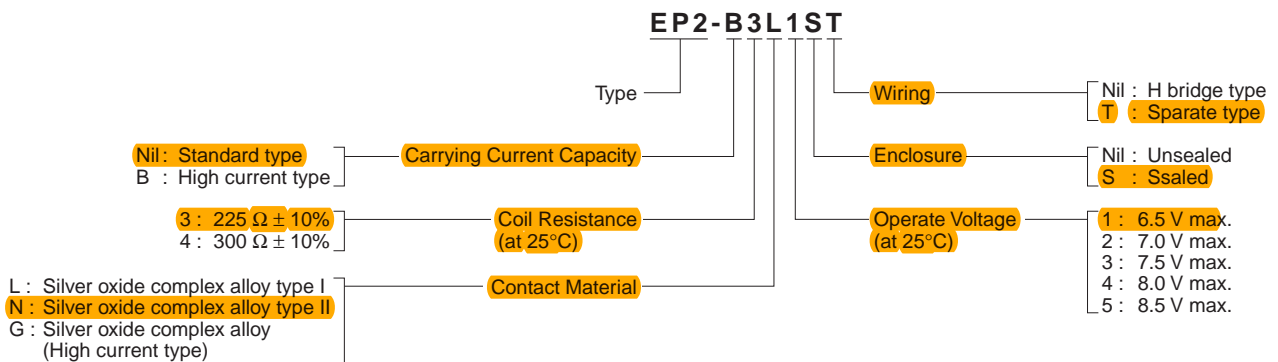

■ **DIMENSIONS** mm (inch)

[H Bridge Type]

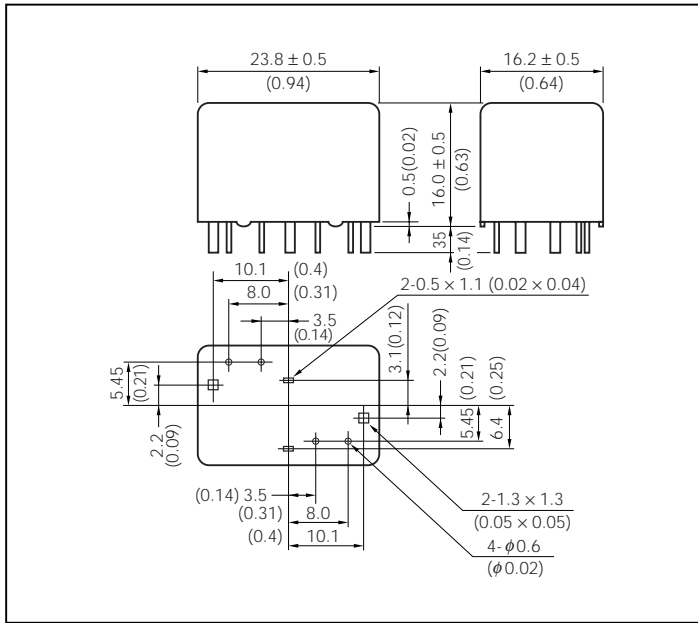

[Separate (T) Type]

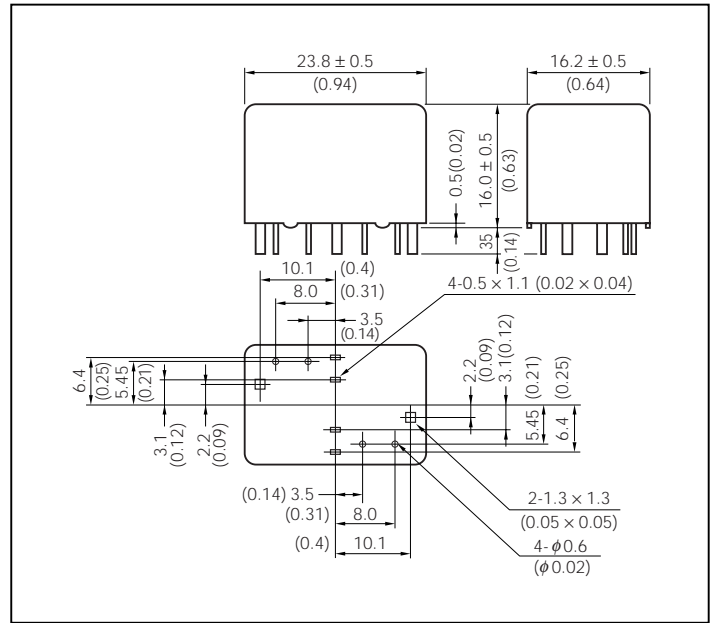

■ **PCB PAD LAYOUT and SCHEMATICS** (bottom view) mm (inch)

[H Bridge Type]

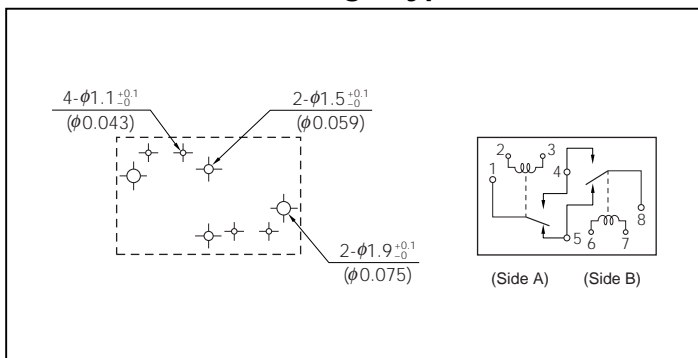

[Separate (T) Type]

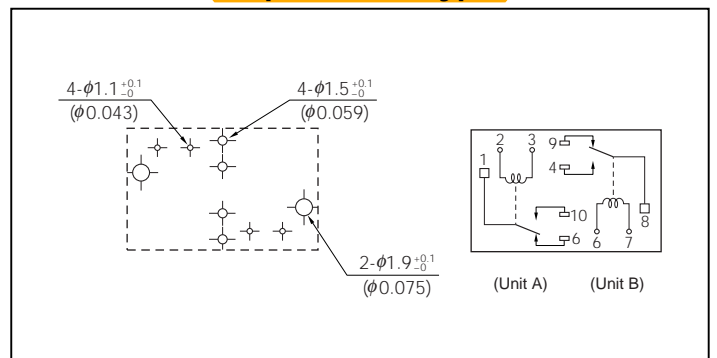

SPECIFICATIONS

at 25°C (77°F)

Items		Specification
Contact Form		1 form C × 2 [H Bridge Type & Separate Type]
Contact Material		Silver oxide complex alloy (Special types available)
Contact Resistance		50 mΩ max. (measured at 7 A) initial
Contact Switching Voltage		30 Vdc max. 5 Vdc min.
Contact Switching Current		25 A max. (at 16 Vdc) 1 A min.
Contact Carrying Current	Standard	20 A max. (2 minutes max.) (at 12 Vdc, 85°C)
	High	25 A max. (2 minutes max.) (at 12 Vdc, 85°C)
Operate Time		Approx. 5 ms max. (at 12 Vdc, excluding bounce) initial
Release Time		Approx. 2 ms max. (at 12 Vdc, excluding bounce) initial, without diode
Nominal Operate Power		0.48 W/0.64 W (at 12 Vdc)
Insulation Resistance		100 MΩ min. (at 500 Vdc) initial
Breakdown Voltage		500 Vdc min. (for 1 minute) initial
Shock Resistance		98 m/s ² [Approx. 10 G] min. (misoperating)
Vibration Resistance		10 to 300 Hz, 43 m/s ² [Approx. 4.4 G] min. (misoperating)
Ambient Temperature		-40°C to +85°C (-40°F to +185°F)
Coil Temperature Rise		50°C/W (contact carrying current 0 A)
Life Expectancy	Mechanical	1 × 10 ⁶ operations
	Electrical	1 × 10 ⁵ operations (at 14 Vdc, Motor Load 20 A/3 A)
Weight		Approx. 15 gr.

EP1 Series

FEATURES

- 33% less relay space than conventional relays (MR301 Series)
- High performance & productivity by unique structure
- Flux tight housing
- Delivered in stick-tube for automatic insertion machine
- Washable type available

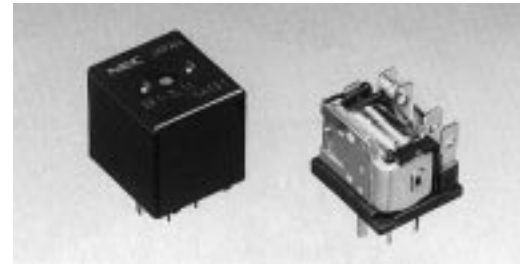

PART NUMBERS AND COIL RATINGS

at 25°C (77°F)

Part Numbers		Nominal Voltage (Vdc)	Coil Resistance ($\Omega \pm 10\%$)	Nominal Current (mA)	Must Operate Voltage (Vdc max.)	Must Release Voltage (Vdc min.)	Nominal Operate Power (W)
Standard Type	High Current Type						
EP1-3L1	EP1-B3G1	12	225	53.3	6.5	0.9	0.64
EP1-3L2	EP1-B3G2	12	225	53.3	7.0	0.9	0.64
EP1-3L3	EP1-B3G3	12	225	53.3	7.5	0.9	0.64
EP1-4L3	EP1-B4G3	12	300	40.0	7.5	0.9	0.48
EP1-4L4	EP1-B4G4	12	300	40.0	8.0	0.9	0.48
EP1-4L5	EP1-B4G5	12	300	40.0	8.5	0.9	0.48

■ PART NUMBER SYSTEM

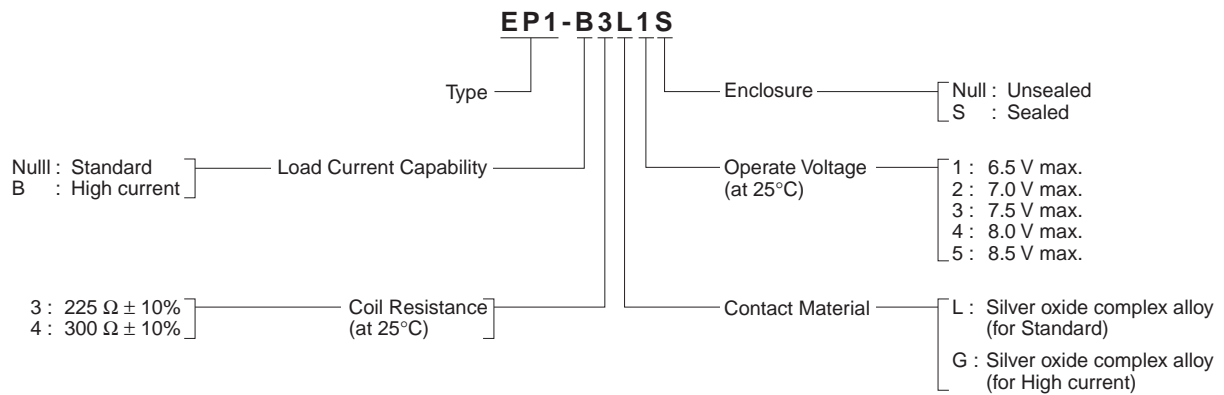

■ DIMENSIONS mm (inch)

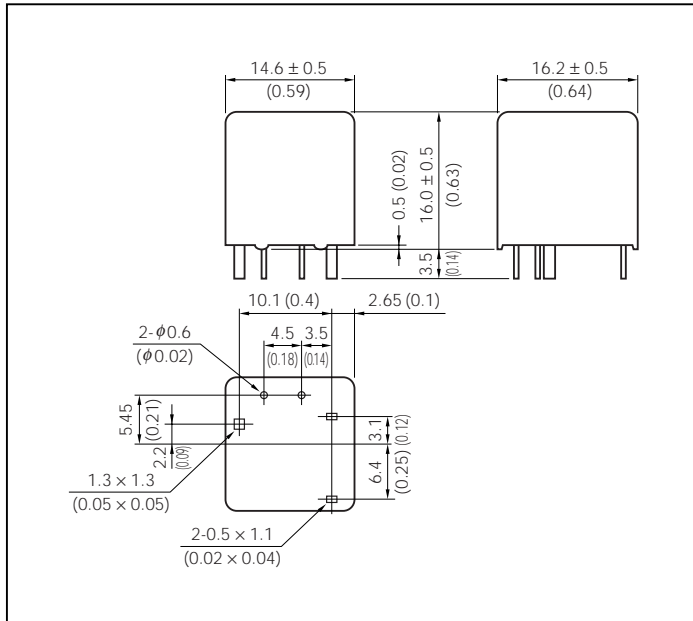

■ PCB PAD LAYOUT and SCHEMATICS (bottom view) mm (inch)

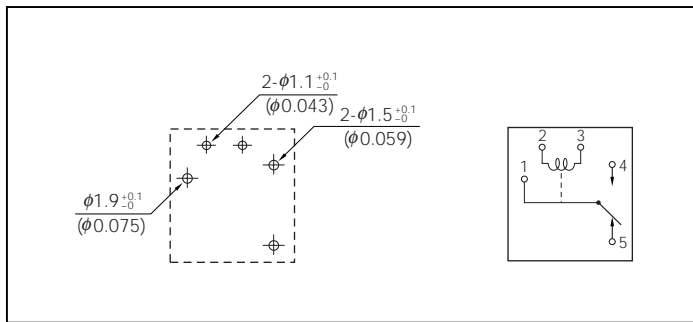

SPECIFICATIONS

at 25°C (77°F)

Items	Specification	
Contact Form	1 form C	
Contact Material	Silver oxide complex alloy	
Contact Resistance	50 MΩ max. (measured at 7 A) initial	
Contact Switching Voltage	30 Vdc max. 5 Vdc min.	
Contact Switching Current	25 A max. (at 16 Vdc) 1 A min.	
Contact Carrying Current	Standard	25 A max. (2 minutes max.) (at 12 Vdc, 85°C)
	High	30 A max. (2 minutes max.) (at 12 Vdc, 85°C)
Operate Time (Excluding bounce)	Approx. 5 ms max. (at 12 Vdc) initial	
Release Time (Excluding bounce)	Approx. 2 ms max. (at 12 Vdc) initial, without diode	
Nominal Operate Power	0.48 W/0.64 W (at 12 Vdc)	
Insulation Resistance	100 MΩ min. (at 500 Vdc) initial	
Breakdown Voltage	500 Vdc min. (for 1 minute) initial	
Shock Resistance	98 m/s ² [Approx. 10 G] min. (misoperating)	
Vibration Resistance	10 to 300 Hz, 43 m/s ² [Approx. 4.4 G] min. (misoperating)	
Coil Temperature Rise	50°C/W (Contact Carrying Current: 0 A)	
Ambient Temperature	-40 to +85°C (-40 to +185°F)	
Life Expectancy	Mechanical	10 ⁶ operations
	Electrical	10 ⁵ operations (at 14 Vdc, Motor Load 20 A/3 A)
Weight	Approx. 8 g	

MR301 Series

FEATURES

- Medium load applications such as interval wipers and stereo
- Delivered in stick-tube for automatic insertion machine
- Flux tight housing
- Washable type available
- High standoff type (0.8 mm) available ("L" suffix)

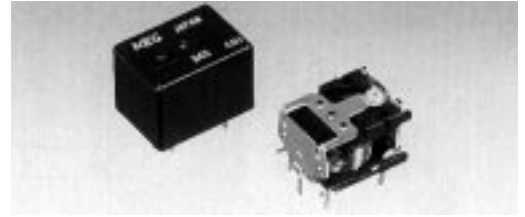

PART NUMBERS AND COIL RATINGS

at 25°C (77°F)

Part Numbers			Nominal Voltage (Vdc)	Coil Resistance ($\Omega \pm 10\%$)	Nominal Current (mA)	Must Operate Voltage (Vdc max.)	Must Release Voltage (Vdc min.)	Nominal Operate Power (W)
5 A Type	10 A Type	15 A Type						
MR301-6SL	MR301-6HSL	MR301-6ESL	6	100	60	4.2	0.6	0.36
MR301-9SL	MR301-9HSL	MR301-9ESL	9	225	40	6.3	0.9	0.36
MR301-N39L	MR301-N40L	MR301-N40EL	12	320	38	8.0	1.2	0.45
MR301-12SL	MR301-12HSL	MR301-12ESL	12	400	30	8.4	1.2	0.36

DIMENSIONS mm (inch)

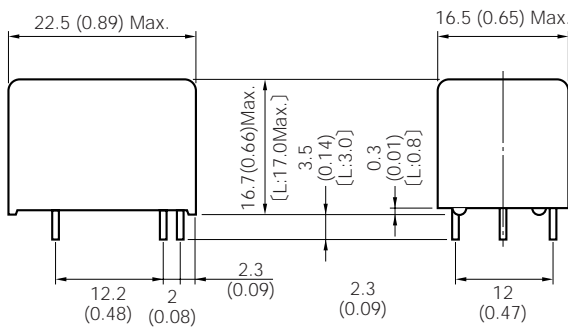

SCHEMATIC (BOTTOM VIEW)

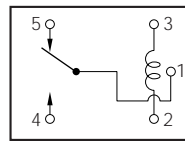

PCB PAD LAYOUT mm (inch) (BOTTOM VIEW)

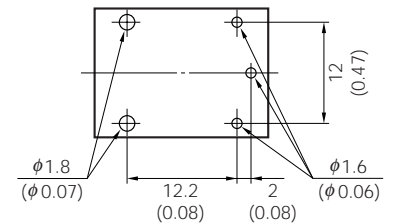

NUMBERING SYSTEM

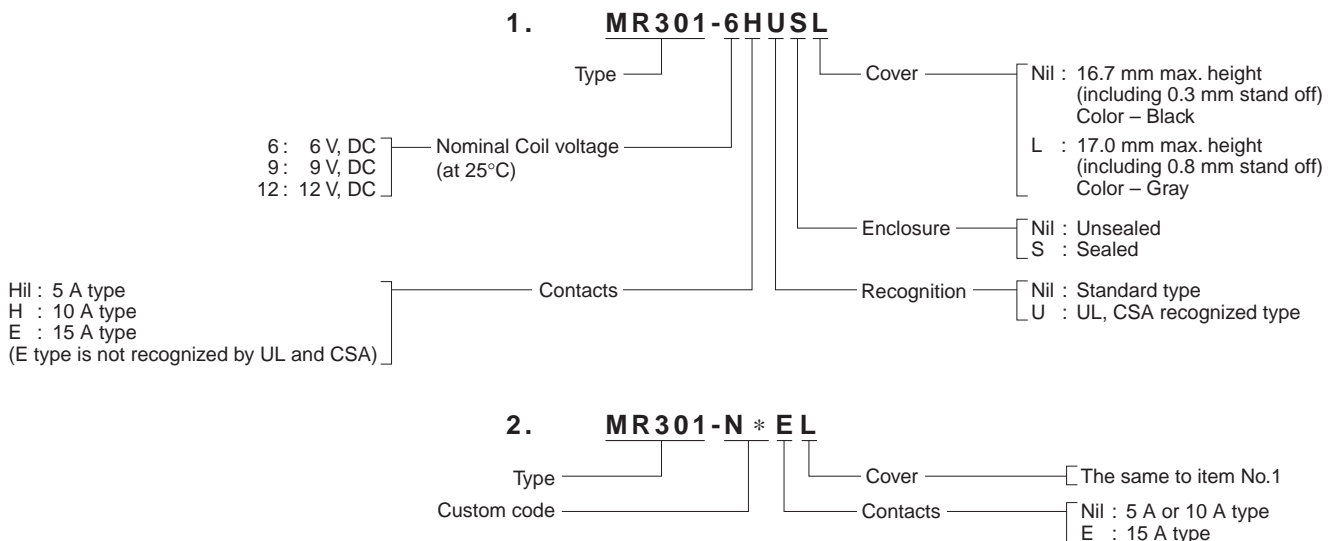

SPECIFICATIONS

at 25°C (77°F)

Items	5 A Type	10/15 A Type
Contact Form	1 form C	
Contact Material	Silver nickel alloy	Silver oxide complex alloy
Contact Resistance	100 mΩ max. (measured at 0.5 A) initial	100 mΩ max. (measured at 2 A) initial
Contact Switching Voltage	30 Vdc max. 5 Vdc min.	
Contact Switching Current	5 A max. (at 16 Vdc) 0.1 A min.	15/20 A max. (at 16 vdc) 1 A min.
Contact Carrying Current	20 A max. (at 12 Vdc)	
Operate Time	Approx. 5 ms max. (at 12 Vdc, excluding bounce) initial	
Release Time	Approx. 2 ms max. (at 12 Vdc, excluding bounce) initial, without diode	
Nominal Operate Power	0.36 W/0.45 W (Nominal Voltage)	
Insulation Resistance	100 MΩ min. (at 500 Vdc) initial	
Breakdown Voltage	500 Vdc min. (for 1 minute) initial	
Shock Resistance	98 m/s ² [Approx. 10 G] min. (misoperating)	
Vibration Resistance	10 to 300 Hz, 43 m/s ² [Approx. 4.4 G] min. (misoperating)	
Ambient Temperature	-40°C to +85°C (-40°F to +185°F)	
Coil Temperature Rise	50°C/W (contact carrying current 0 A)	
Life Expectancy	Mechanical	1 x 10 ⁶ operations
	Electrical	1 x 10 ⁵ operations (at 14 Vdc, Motor Load 20 A/3 A) (E-Contact)
Weight	Approx. 13 gr	

NOTICE

(1) Capacitive load

If the load is capacitive, an inrush current to charge the load with poses a problem. In this case, a current-limiting resistor or surge suppressor coil is connected in series to the contacts to suppress the peak current.

(2) Clinching terminals

To secure the relay temporarily to a printed circuit board for soldering, particular terminals are allowed to be clinched within a particular angle. Other terminals, never clinched.

The terminal numbers and the angle for clinching of each series are as follows.

- 1) No.4 and no.5 terminals to 45° maximum for H bridge type of EN2 and EP2
- 2) No.5 and no.9 terminals to 45° maximum for separate type of EN2 and EP2
- 3) No.4 and no.5 terminals to 45° maximum for EP1
- 4) No.1, 4 and no.5 terminals to 45° maximum for MR301

(3) Drive circuit

Since the coil of a relay has an inductive impedance, a counter electromotive force is generated when the circuit is opened. This voltage may damage the relay driver IC. Therefore, a diode is connected in parallel with the coil, as shown in figure 1.

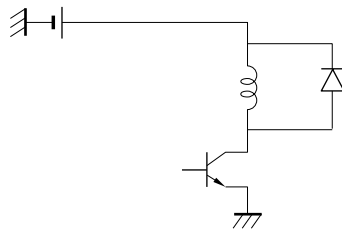
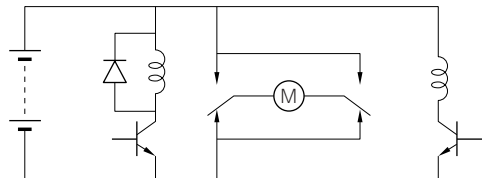
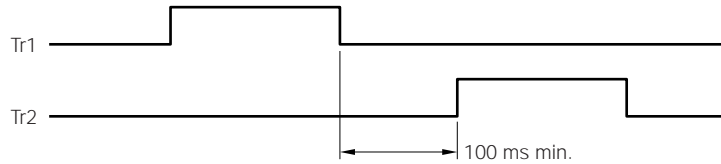

Figure 1

(4) Typical application for EN2/EP2 relays (H bridge type)



MOTOR	Tr1	Tr2
STOP	off	off
FORWARD	on	off
REVERSE	off	on



APPLICATIONS

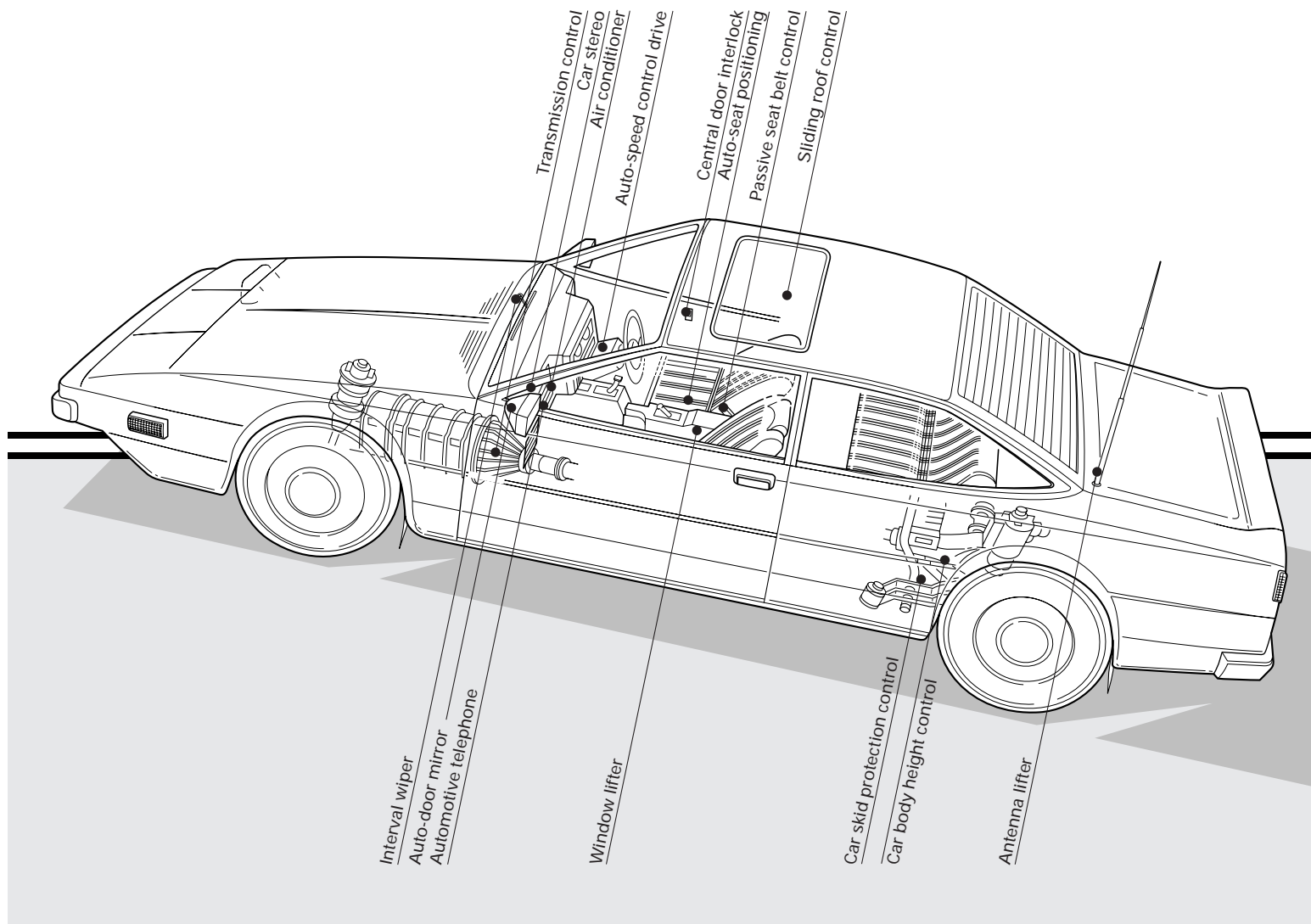

No part of this document may be copied in any form or by any means without the prior written consent of NEC Corporation.

NEC Corporation does not assume any liability for infringement of patents, copyrights or other intellectual property rights of third parties by or arising from use of a device described herein or any other liability arising from use of such device. No license, either express, implied or otherwise, is granted under any patents, copyrights or other intellectual property rights of NEC Corporation or of others.



This datasheet has been download from:

www.datasheetcatalog.com

Datasheets for electronics components.