

HIGH VOLTAGE (HV) OUTDOOR TERMINATION DRY TYPE OHVT-145G (4G) UP TO 145 kV

KEY FEATURES

- Pressure-tight and light weight composite housing
- Prefabricated and factory tested silicone rubber stress cone
- No special tools or gluing required to install the termination
- No leakages due to Gel (Rayfil®) filling
- Ready for usage after installation
- Type and Routine tested according to IEC 60840 standards
- No additional training required - similar design as standard OHVT-C

TE Connectivity's (TE) Raychem High Voltage Outdoor Termination (OHVT) Dry Type is designed for voltages up to 245 kV and to operate under severe environmental conditions. The OHVT is compatible with polymeric insulated cables independent of the manufacturer and can be adapted with respect to grounding required for various cable constructions.

Composite housing with different creepage lengths are available and cover all pollution levels. The installation of the termination can be done by trained installer equipped with conventional tools. The termination is designed according to the following standards: IEC-60840, IEC-62067, IEC-60815, IEEE-48, IEEE-1313.

The pressure-tight composite housing is made of a Glass Fiber Reinforced (GFR) resin tube with silicone rubber sheds molded to the tube. The metal fitted associated with the termination consists of a corrosion-free alloy. The cable lug is available both in crimp and shear-off bolt version. It is suitable for all common conductors made of aluminium or copper. The interface between stress cone, cable insulation and inner housing will be filled from the top with fast curing gel. The advantage of a dry type termination over a conventional oil filled type is that the gel filling cures over a time period causing no leakages.

Customers can count on consistent, high quality products, driven by TE's proven innovation and backed by our extraordinary customer support.

HV Outdoor Terminations Dry Type OHVT-145G (4C)



MECHANICAL DATA	
Length without connection bolt	2980 mm
Outer diameter of insulator	355 mm
Inner diameter of insulator	248 mm
Cantilever force	4000 N
Max. permissible radial pull at connection bolt	2000 N
Diameter of connection bolt	30/40/50/60 mm
Length of connection bolt	100/130 mm
Earth connection	4 x M12
Weight approx.	265 kg
Insulating Medium Volume	50 l
Packing information	2745 x 900 x 630 mm

DESIGN DATA	
Diameter over insulation	34 - 108 mm
Diameter over sheath	135 mm
Max. Cross section (Cu / Al)	Approx. 3000 mm ²
Creepage distance	9436 mm
Protected creepage distance [90°C shadow]	2930 mm
Flashover distance	2626 mm
Material of connection bolt	Aluminium / Copper
Material of insulator - outer surface	Silicone rubber
Profile of insulator	Alternating sheds
Colour of insulator	Grey
Method of stress control	Geometric
Stress cone	Pre-fabricated silicone rubber
Max. permissible dielectric stress	4 kV/mm (at insulation screen of cable)
Insulating medium	Gel (Rayfil®)
Material of fittings	Aluminium
Clearance between terminations	As per IEC 60071-1
Installation temperature	0°C - +50°C
Operation temperature	-55°C - +55°C
Storage temperature	0°C - +40°C

ELECTRICAL TYPE TEST IEC 60840	
Heating cycle voltage	152 kV
Partial discharge at ambient and elevated temperatures	114 kV
Lightning impulse voltage 1.2µs/50µs	650 kV
ELECTRICAL TYPE TEST IEC 60840 ANNEX H	
AC withstand test screen to ground	25 kV
DC withstand test screen to ground	25 kV
Lightning impulse test screen to ground	37.5 kV
ELECTRICAL ROUTINE TEST IEC 60840	
AC withstand voltage	190 kV
Partial discharge test	114 kV

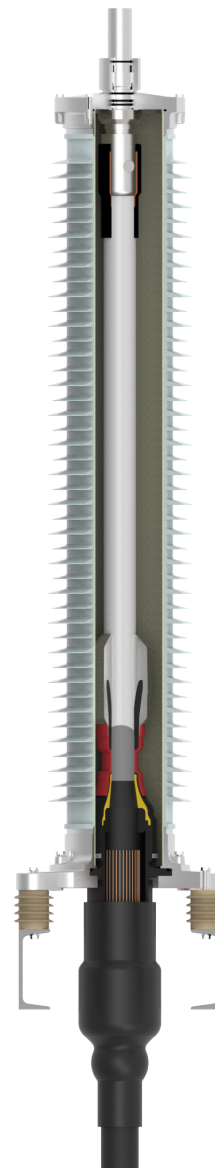

te.com/energy

© 2019 TE Connectivity. All Rights Reserved. EPP-3281-DDS-7/19-Termination-OHVT-145G-4G-TE

Raychem, Rayfil, TE Connectivity and TE connectivity (logo) are trademarks. Other logos, product and/or company names might be trademarks of their respective owners. While TE has made every reasonable effort to ensure the accuracy of the information in this brochure, TE does not guarantee that it is error-free, nor does TE make any other representation, warranty or guarantee that the information is accurate, correct, reliable or current. TE reserves the right to make any adjustments to the information contained herein at any time without notice. TE expressly disclaims all implied warranties regarding the information contained herein, including, but not limited to, any implied warranties of merchantability or fitness for a particular purpose. The dimensions in this catalog are for reference purposes only and are subject to change without notice. Specifications are subject to change without notice. Consult TE for the latest dimensions and design specifications.

FOR MORE INFORMATION: TE Technical Support Centers

USA:	+ 1 800 327 6996
Canada:	+ 1 (905) 475-6222
Mexico:	+ 52 (0) 55-1106-0800
Latin/S. America:	+ 54 (0) 11-4733-2200
France:	+ 33 380 583 200
UK:	+ 44 0870 870 7500
Germany:	+ 49 896 089 903
Spain:	+ 34 916 630 400
Italy:	+ 39 333 250 0915
Benelux:	+ 32 16 508 695
Russia:	+ 7 495-790 790 2-200
China:	+ 86 (0) 400-820-6015

While TE Connectivity (TE) has made every reasonable effort to ensure the accuracy of the information in the catalog, TE does not guarantee that it is error free, nor does TE make any other representation, warranty or implied warranties regarding the information contained herein, including, but not limited to, any implied warranties or merchantability or fitness for a particular purpose. The dimensions in this catalog are for reference purpose only and are subject to change without notice. Specifications are subject to change without notice. Consult TE for the latest dimensions and design specifications.

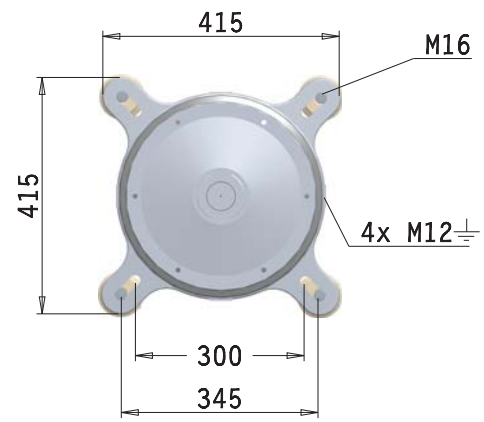
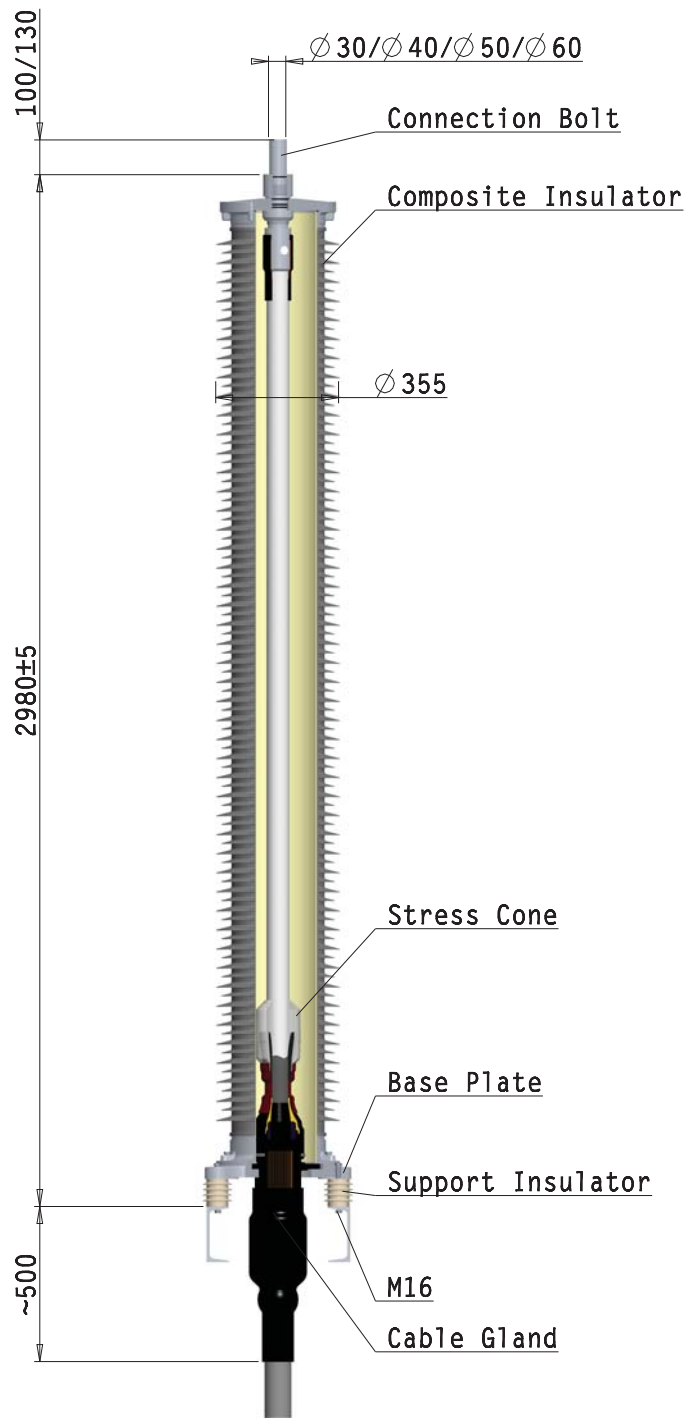

DRY TYPE OUTDOOR-TERMINATION
145 kV
COMPOSITE-INSULATOR
FOR POLYMERIC-CABLE

OHVT-145G (-4G)
Offer drawing



Raychem High Voltage Cable Accessories

TE Connectivity drawing no: EPD-204-2149-00 REV. 1