

**EN25QH16****16 Megabit Serial Flash Memory with 4Kbyte Uniform Sector****FEATURES**

- Single power supply operation
  - Full voltage range: 2.7-3.6 volt
- Serial Interface Architecture
  - SPI Compatible: Mode 0 and Mode 3
- 16 M-bit Serial Flash
  - 16 M-bit/2,048 K-byte/8,192 pages
  - 256 bytes per programmable page
- Standard, Dual or Quad SPI
  - Standard SPI: CLK, CS#, DI, DO, WP#, HOLD#
  - Dual SPI: CLK, CS#, DQ<sub>0</sub>, DQ<sub>1</sub>, WP#, HOLD#
  - Quad SPI: CLK, CS#, DQ<sub>0</sub>, DQ<sub>1</sub>, DQ<sub>2</sub>, DQ<sub>3</sub>
- High performance
  - 104MHz clock rate for Standard SPI
  - 80MHz clock rate for two data bits
  - 80MHz clock rate for four data bits
- Low power consumption
  - 12 mA typical active current
  - 1  $\mu$ A typical power down current
- Uniform Sector Architecture:
  - 512 sectors of 4-Kbyte
  - 32 blocks of 64-Kbyte
  - Any sector or block can be erased individually
- Software and Hardware Write Protection:
  - Write Protect all or portion of memory via software
  - Enable/Disable protection with WP# pin
- High performance program/erase speed
  - Page program time: 1.3ms typical
  - Sector erase time: 60ms typical
  - Block erase time 400ms typical
  - Chip erase time: 12 seconds typical
- Lockable 512 byte OTP security sector
- Support Serial Flash Discoverable Parameters (SFDP) signature
- Read Unique ID Number
- Minimum 100K endurance cycle
- Package Options
  - 8 pins SOP 150mil body width
  - 8 pins SOP 200mil body width
  - 8 contact VDFN (5x6mm)
  - 8 pins PDIP
  - 24 balls TFBGA (6x8mm)
  - All Pb-free packages are RoHS compliant
- Industrial temperature Range

**GENERAL DESCRIPTION**

The EN25QH16 is a 16 Megabit (2,048 K-byte) Serial Flash memory, with enhanced write protection mechanisms. The EN25QH16 supports the standard Serial Peripheral Interface (SPI), and a high performance Dual/Quad output as well as Dual/Quad I/O using SPI pins: Serial Clock, Chip Select, Serial DQ<sub>0</sub>(DI), DQ<sub>1</sub>(DO), DQ<sub>2</sub>(WP#) and DQ<sub>3</sub>(HOLD#). SPI clock frequencies of up to 80MHz are supported allowing equivalent clock rates of 160MHz (80MHz x 2) for Dual Output and 320MHz (80MHz x 4) for Quad Output when using the Dual/Quad I/O Fast Read instructions. The memory can be programmed 1 to 256 bytes at a time, using the Page Program instruction.

The EN25QH16 is designed to allow either single Sector/Block at a time or full chip erase operation. The EN25QH16 can be configured to protect part of the memory as the software protected mode. The device can sustain a minimum of 100K program/erase cycles on each sector or block.

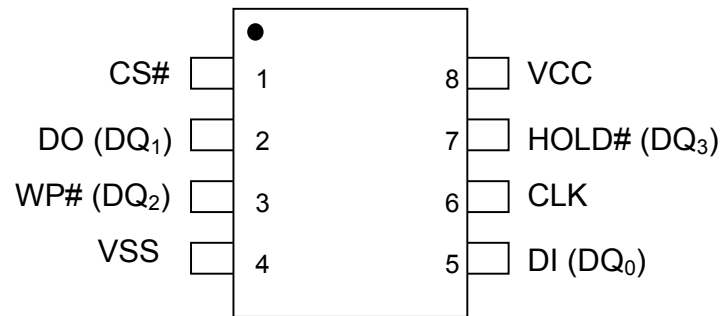
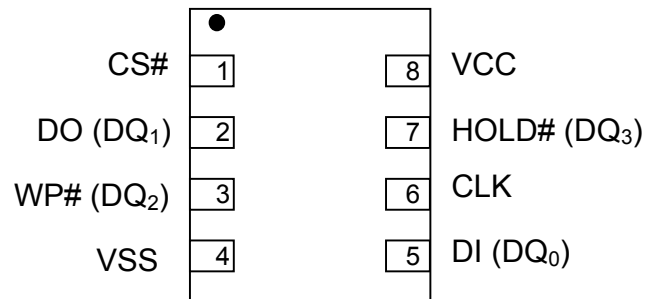
**Figure.1 CONNECTION DIAGRAMS**

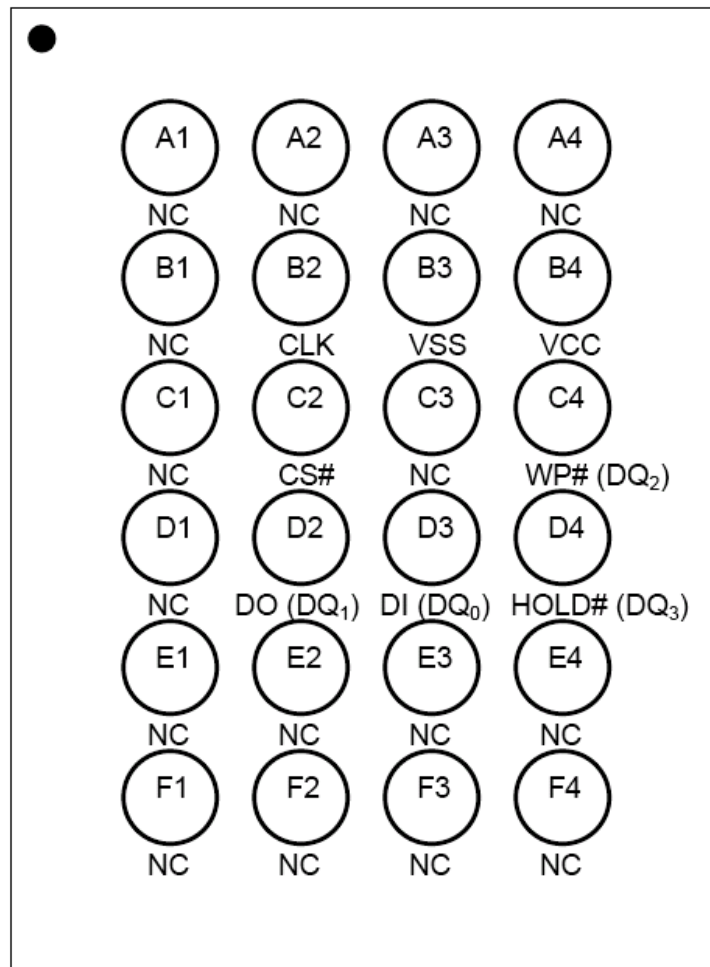
**8 - LEAD SOP / PDIP**

**8 - LEAD VDFN**

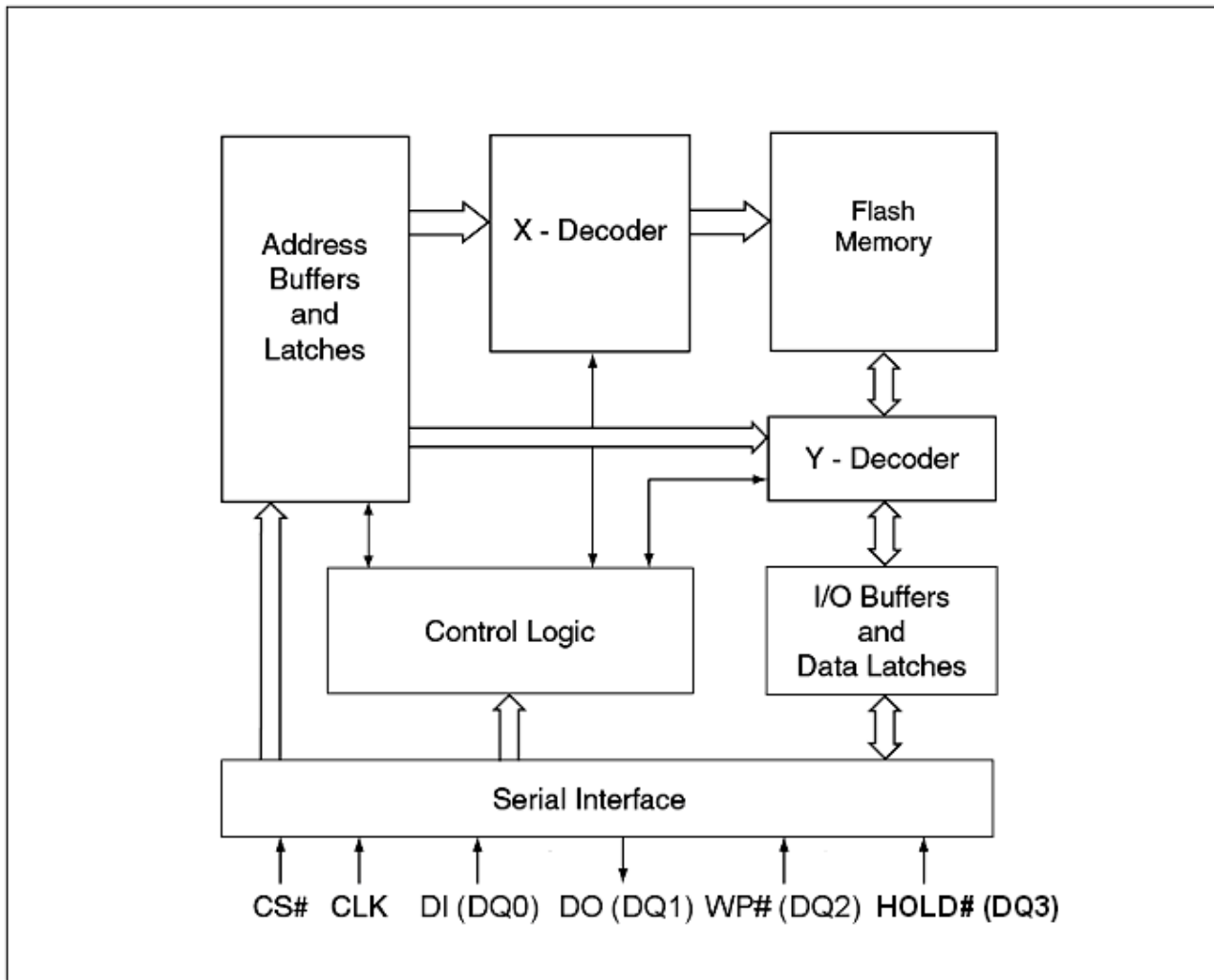
**Top View, Balls Facing Down**

24 - Ball TFBGA

**Figure 2. BLOCK DIAGRAM**

**Note:**

1. DQ<sub>0</sub> and DQ<sub>1</sub> are used for Dual and Quad instructions.
2. DQ<sub>0</sub> ~ DQ<sub>3</sub> are used for Quad instructions.



Table 1. Pin Names

Symbol	Pin Name
CLK	Serial Clock Input
DI (DQ <sub>0</sub> )	Serial Data Input (Data Input Output 0) <sup>*1</sup>
DO (DQ <sub>1</sub> )	Serial Data Output (Data Input Output 1) <sup>*1</sup>
CS#	Chip Select
WP# (DQ <sub>2</sub> )	Write Protect (Data Input Output 2) <sup>*2</sup>
HOLD# (DQ <sub>3</sub> )	HOLD# pin (Data Input Output 3) <sup>*2</sup>
Vcc	Supply Voltage (2.7-3.6V)
Vss	Ground
NC	No Connect

Note:

1. DQ<sub>0</sub> and DQ<sub>1</sub> are used for Dual and Quad instructions.
2. DQ<sub>2</sub> ~ DQ<sub>3</sub> are used for Quad instructions.

## SIGNAL DESCRIPTION

### Serial Data Input, Output and IOs (DI, DO and DQ<sub>0</sub>, DQ<sub>1</sub>, DQ<sub>2</sub>, DQ<sub>3</sub>)

The EN25QH16 support standard SPI, Dual SPI and Quad SPI operation. Standard SPI instructions use the unidirectional DI (input) pin to serially write instructions, addresses or data to the device on the rising edge of the Serial Clock (CLK) input pin. Standard SPI also uses the unidirectional DO (output) to read data or status from the device on the falling edge CLK.

Dual and Quad SPI instruction use the bidirectional IO pins to serially write instruction, addresses or data to the device on the rising edge of CLK and read data or status from the device on the falling edge of CLK.

### Serial Clock (CLK)

The SPI Serial Clock Input (CLK) pin provides the timing for serial input and output operations. ("See SPI Mode")

### Chip Select (CS#)

The SPI Chip Select (CS#) pin enables and disables device operation. When CS# is high the device is deselected and the Serial Data Output (DO, or DQ<sub>0</sub>, DQ<sub>1</sub>, DQ<sub>2</sub> and DQ<sub>3</sub>) pins are at high impedance. When deselected, the devices power consumption will be at standby levels unless an internal erase, program or status register cycle is in progress. When CS# is brought low the device will be selected, power consumption will increase to active levels and instructions can be written to and data read from the device. After power-up, CS# must transition from high to low before a new instruction will be accepted.

### Hold (HOLD#)

The HOLD# pin allows the device to be paused while it is actively selected. When HOLD# is brought low, while CS# is low, the DO pin will be at high impedance and signals on the DI and CLK pins will be ignored (don't care). The hold function can be useful when multiple devices are sharing the same SPI signals. The HOLD# function is only available for standard SPI and Dual SPI operation, when during Quad SPI, this pin is the Serial Data IO (DQ<sub>3</sub>) for Quad I/O operation.

### Write Protect (WP#)

The Write Protect (WP#) pin can be used to prevent the Status Register from being written. Used in conjunction with the Status Register's Block Protect (BP0, BP1, BP2 and BP3) bits and Status Register Protect (SRP) bits, a portion or the entire memory array can be hardware protected. The WP# function is only available for standard SPI and Dual SPI operation, when during Quad SPI, this pin is the Serial Data IO (DQ<sub>2</sub>) for Quad I/O operation.

**MEMORY ORGANIZATION**

The memory is organized as:

- 2,097,152 bytes
- Uniform Sector Architecture
  - 32 blocks of 64-Kbyte
  - 512 sectors of 4-Kbyte
  - 8,192 pages (256 bytes each)

Each page can be individually programmed (bits are programmed from 1 to 0). The device is Sector, Block or Chip Erasable but not Page Erasable.



Table 2. Uniform Block Sector Architecture

Block	Sector	Address range	
31	511	1FF000h	1FFFFFFh
	⋮	⋮	⋮
30	496	1F0000h	1F0FFFh
	495	1EF000h	1EFFFFh
29	480	1E0000h	1E0FFFh
	479	1DF000h	1DFFFFh
28	464	1D0000h	1D0FFFh
	463	1CF000h	1CFFFFh
27	448	1C0000h	1C0FFFh
	447	1BF000h	1BFFFFh
26	432	1B0000h	1B0FFFh
	431	1AF000h	1AFFFFh
25	416	1A0000h	1A0FFFh
	415	19F000h	19FFFF
24	400	190000h	190FFFh
	399	18F000h	18FFFFh
23	384	180000h	180FFFh
	383	17F000h	17FFFFh
22	368	170000h	170FFFh
	367	16F000h	16FFFFh
21	352	160000	160FFFh
	351	15F000	15FFFFh
20	336	150000h	150FFFh
	335	14F000h	14FFFFh
19	320	140000h	140FFFh
	319	13F000h	13FFFFh
18	304	130000h	130FFFh
	303	12F000h	12FFFFh
17	288	120000h	120FFFh
	287	11F000h	11FFFFh
16	272	110000h	110FFFh
	271	10F000h	10FFFFh
	256	100000h	100FFFh

Block	Sector	Address range	
15	255	0FF000h	0FFFFFFh
	240	0F0000h	0F0FFFh
14	239	0EF000h	0EFFFFh
	224	0E0000h	0E0FFFh
13	223	0DF000h	0DFFFFh
	208	0D0000h	0D0FFFh
12	207	0CF000h	0CFFFFh
	192	0C0000h	0C0FFFh
11	191	0BF000h	0BFFFFh
	176	0B0000h	0B0FFFh
10	175	0AF000h	0AFFFFh
	160	0A0000h	0A0FFFh
9	159	09F000h	09FFFFh
	144	090000h	090FFFh
8	143	08F000h	08FFFFh
	128	080000h	080FFFh
7	127	07F000h	07FFFFh
	112	070000h	070FFFh
6	111	06F000h	06FFFFh
	96	060000h	060FFFh
5	95	05F000h	05FFFFh
	80	050000h	050FFFh
4	79	04F000h	04FFFFh
	64	040000h	040FFFh
3	63	03F000h	03FFFFh
	48	030000h	030FFFh
2	47	02F000h	02FFFFh
	32	020000h	020FFFh
1	31	01F000h	01FFFFh
	16	010000h	010FFFh
0	15	00F000h	00FFFFh
	4	004000h	004FFFh
	3	003000h	003FFFh
	2	002000h	002FFFh
	1	001000h	001FFFh
	0	000000h	000FFFh

## OPERATING FEATURES

### Standard SPI Modes

The EN25QH16 is accessed through a SPI compatible bus consisting of four signals: Serial Clock (CLK), Chip Select (CS#), Serial Data Input (DI) and Serial Data Output (DO). Both SPI bus operation Modes 0 (0,0) and 3 (1,1) are supported. The primary difference between Mode 0 and Mode 3, as shown in Figure 3, concerns the normal state of the CLK signal when the SPI bus master is in standby and data is not being transferred to the Serial Flash. For Mode 0 the CLK signal is normally low. For Mode 3 the CLK signal is normally high. In either case data input on the DI pin is sampled on the rising edge of the CLK. Data output on the DO pin is clocked out on the falling edge of CLK.

**Figure 3. SPI Modes**

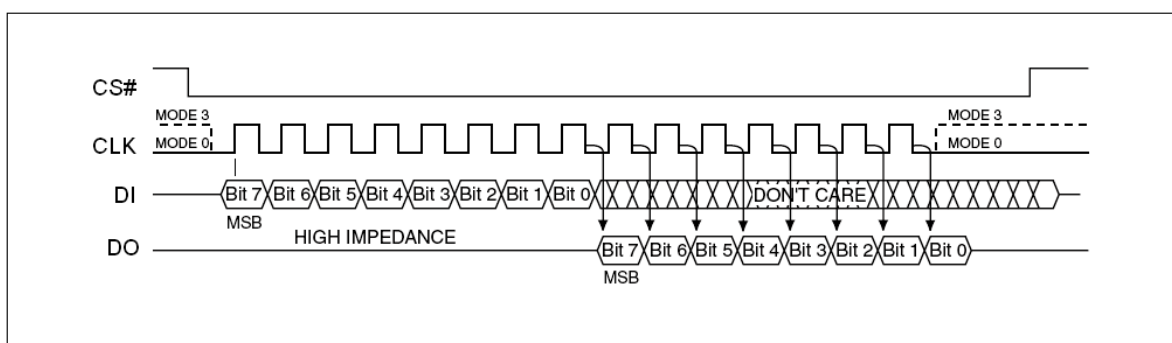

### Dual SPI Instruction

The EN25QH16 supports Dual SPI operation when using the “Dual Output Fast Read and Dual I/O Fast Read “ (3Bh and BBh) instructions. These instructions allow data to be transferred to or from the Serial Flash memory at two to three times the rate possible with the standard SPI. The Dual Read instructions are ideal for quickly downloading code from Flash to RAM upon power-up (code-shadowing) or for application that cache code-segments to RAM for execution. The Dual output feature simply allows the SPI input pin to also serve as an output during this instruction. When using Dual SPI instructions the DI and DO pins become bidirectional I/O pins; DQ<sub>0</sub> and DQ<sub>1</sub>. All other operations use the standard SPI interface with single output signal.

### Quad SPI Instruction

The EN25QH16 supports Quad output operation when using the Quad I/O Fast Read (EBh). This instruction allows data to be transferred to or from the Serial Flash memory at four to six times the rate possible with the standard SPI. The Quad Read instruction offer a significant improvement in continuous and random access transfer rates allowing fast code-shadowing to RAM or for application that cache code-segments to RAM for execution. The EN25QH16 also supports full Quad Mode function while using the Enable Quad Peripheral Interface mode (EQPI) (38h). When using Quad SPI instruction the DI and DO pins become bidirectional I/O pins; DQ<sub>0</sub> and DQ<sub>1</sub>, and the WP# and HOLD# pins become DQ<sub>2</sub> and DQ<sub>3</sub> respectively.

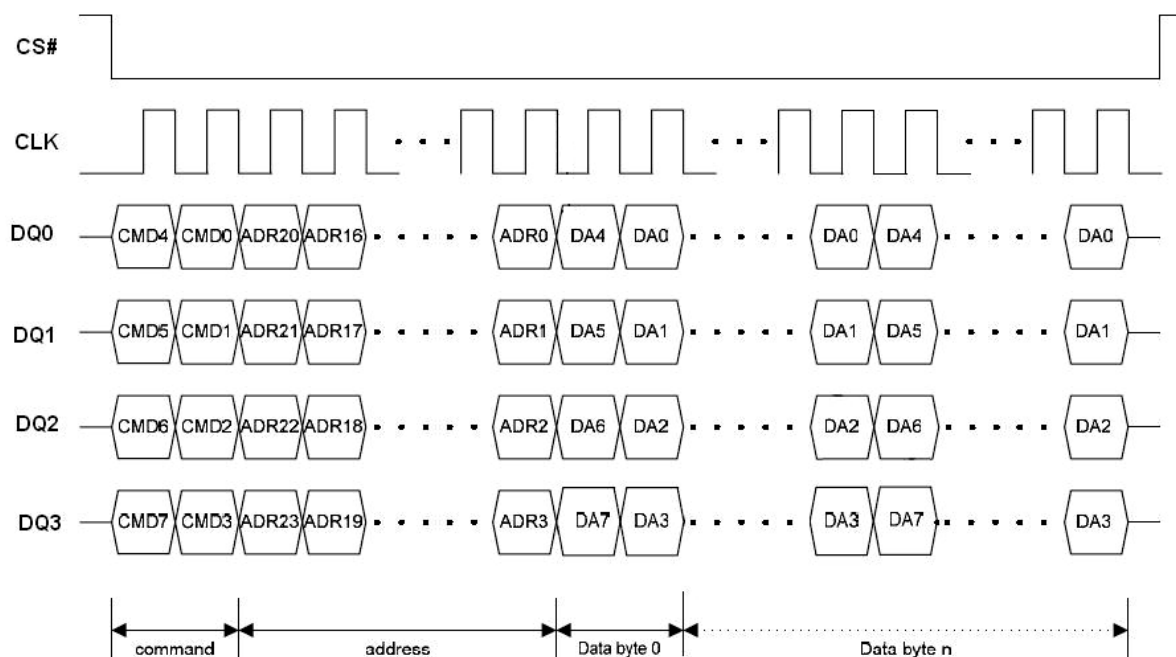
**Figure 4. Quad SPI Modes**

### Page Programming

To program one data byte, two instructions are required: Write Enable (WREN), which is one byte, and a Page Program (PP) sequence, which consists of four bytes plus data. This is followed by the internal Program cycle (of duration  $t_{PP}$ ).

To spread this overhead, the Page Program (PP) instruction allows up to 256 bytes to be programmed at a time (changing bits from 1 to 0) provided that they lie in consecutive addresses on the same page of memory.

### Sector Erase, Block Erase and Chip Erase

The Page Program (PP) instruction allows bits to be reset from 1 to 0. Before this can be applied, the bytes of memory need to have been erased to all 1s (FFh). This can be achieved a sector at a time, using the Sector Erase (SE) instruction, a block at a time using the Block Erase (BE) instruction or throughout the entire memory, using the Chip Erase (CE) instruction. This starts an internal Erase cycle (of duration  $t_{SE}$ ,  $t_{BE}$  or  $t_{CE}$ ). The Erase instruction must be preceded by a Write Enable (WREN) instruction.

### Polling During a Write, Program or Erase Cycle

A further improvement in the time to Write Status Register (WRSR), Program (PP) or Erase (SE, BE or CE) can be achieved by not waiting for the worst case delay ( $t_W$ ,  $t_{PP}$ ,  $t_{SE}$ ,  $t_{BE}$  or  $t_{CE}$ ). The Write In Progress (WIP) bit is provided in the Status Register so that the application program can monitor its value, polling it to establish when the previous Write cycle, Program cycle or Erase cycle is complete.

### Active Power, Stand-by Power and Deep Power-Down Modes

When Chip Select (CS#) is Low, the device is enabled, and in the Active Power mode. When Chip Select (CS#) is High, the device is disabled, but could remain in the Active Power mode until all internal cycles have completed (Program, Erase, and Write Status Register). The device then goes into the Stand-by Power mode. The device consumption drops to  $I_{CC1}$ .

The Deep Power-down mode is entered when the specific instruction (the Enter Deep Power-down Mode (DP) instruction) is executed. The device consumption drops further to  $I_{CC2}$ . The device remains in this mode until another specific instruction (the Release from Deep Power-down Mode and Read Device ID (RDI) instruction) is executed.



All other instructions are ignored while the device is in the Deep Power-down mode. This can be used as an extra software protection mechanism, when the device is not in active use, to protect the device from inadvertent Write, Program or Erase instructions.

### Status Register

The Status Register contain a number of status and control bits that can be read or set (as appropriate) by specific instructions.

**WIP bit.** The Write In Progress (WIP) bit indicates whether the memory is busy with a Write Status Register, Program or Erase cycle.

**WEL bit.** The Write Enable Latch (WEL) bit indicates the status of the internal Write Enable Latch.

**BP3, BP2, BP1, BP0 bits.** The Block Protect (BP3, BP2, BP1, BP0) bits are non-volatile. They define the size of the area to be software protected against Program and Erase instructions.

**WHDIS bit.** The WP# and Hold# Disable bit (WHDIS bit), non-volatile bit, it indicates the WP# and HOLD# are enabled or not. When it is "0" (factory default), the WP# and HOLD# are enabled. On the other hand, while WHDIS bit is "1", the WP# and HOLD# are disabled. If the system executes Quad Input/Output FAST\_READ (EBh) or EQPI (38h) command, this WHDIS bit becomes no affection since WP# and HOLD# function will be disabled by Quad Input/Output FAST\_READ (EBh) or EQPI mode.

**SRP bit / OTP\_LOCK bit** The Status Register Protect (SRP) bit operates in conjunction with the Write Protect (WP#) signal. The Status Register Protect (SRP) bit and Write Protect (WP#) signal allow the device to be put in the Hardware Protected mode. In this mode, the non-volatile bits of the Status Register (SRP, BP3, BP2, BP1, BP0) become read-only bits.

In OTP mode, this bit serves as OTP\_LOCK bit, user can read/program/erase OTP sector as normal sector while OTP\_LOCK bit value is equal 0, after OTP\_LOCK bit is programmed with 1 by WRSR command, the OTP sector is protected from program and erase operation. The OTP\_LOCK bit can only be programmed once.

**Note :** In OTP mode, the WRSR command will ignore any input data and program OTP\_LOCK bit to 1, user must clear the protect bits before entering OTP mode and program the OTP code, then execute WRSR command to lock the OTP sector before leaving OTP mode.

### Write Protection

Applications that use non-volatile memory must take into consideration the possibility of noise and other adverse system conditions that may compromise data integrity. To address this concern the EN25QH16 provides the following data protection mechanisms:

- Power-On Reset and an internal timer ( $t_{PUW}$ ) can provide protection against inadvertent changes while the power supply is outside the operating specification.
- Program, Erase and Write Status Register instructions are checked that they consist of a number of clock pulses that is a multiple of eight, before they are accepted for execution.
- All instructions that modify data must be preceded by a Write Enable (WREN) instruction to set the Write Enable Latch (WEL) bit. This bit is returned to its reset state by the following events:
  - Power-up
  - Write Disable (WRDI) instruction completion or Write Status Register (WRSR) instruction completion or Page Program (PP) instruction completion or Sector Erase (SE) instruction completion or Block Erase (BE) instruction completion or Chip Erase (CE) instruction completion
- The Block Protect (BP3, BP2, BP1, BP0) bits allow part of the memory to be configured as read-only. This is the Software Protected Mode (SPM).
- The Write Protect (WP#) signal allows the Block Protect (BP3, BP2, BP1, BP0) bits and Status Register Protect (SRP) bit to be protected. This is the Hardware Protected Mode (HPM).
- In addition to the low power consumption feature, the Deep Power-down mode offers extra software protection from inadvertent Write, Program and Erase instructions, as all instructions are ignored except one particular instruction (the Release from Deep Power-down instruction).



Table 3. Protected Area Sizes Sector Organization

Status Register Content				Memory Content			
BP3 Bit	BP2 Bit	BP1 Bit	BP0 Bit	Protect Areas	Addresses	Density(KB)	Portion
0	0	0	0	None	None	None	None
0	0	0	1	Block 31	1F0000h-1FFFFFFh	64KB	Upper 1/32
0	0	1	0	Block 30 to 31	1E0000h-1FFFFFFh	128KB	Upper 2/32
0	0	1	1	Block 28 to 31	1C0000h-1FFFFFFh	256KB	Upper 4/32
0	1	0	0	Block 24 to 31	180000h-1FFFFFFh	512KB	Upper 8/32
0	1	0	1	Block 16 to 31	100000h-1FFFFFFh	1024KB	Upper 16/32
0	1	1	0	All	000000h-1FFFFFFh	2048KB	All
0	1	1	1	All	000000h-1FFFFFFh	2048KB	All
1	0	0	0	None	None	None	None
1	0	0	1	Block 0	000000h-00FFFFh	64KB	Lower 1/32
1	0	1	0	Block 0 to 1	000000h-01FFFFh	128KB	Lower 2/32
1	0	1	1	Block 0 to 3	000000h-03FFFFh	256KB	Lower 4/32
1	1	0	0	Block 0 to 7	000000h-07FFFFh	512KB	Lower 8/32
1	1	0	1	Block 0 to 15	000000h-0FFFFFFh	1024KB	Lower 16/32
1	1	1	0	All	000000h-1FFFFFFh	2048KB	All
1	1	1	1	All	000000h-1FFFFFFh	2048KB	All

## INSTRUCTIONS

All instructions, addresses and data are shifted in and out of the device, most significant bit first. Serial Data Input (DI) is sampled on the first rising edge of Serial Clock (CLK) after Chip Select (CS#) is driven Low. Then, the one-byte instruction code must be shifted in to the device, most significant bit first, on Serial Data Input (DI), each bit being latched on the rising edges of Serial Clock (CLK).

The instruction set is listed in Table 4. Every instruction sequence starts with a one-byte instruction code. Depending on the instruction, this might be followed by address bytes, or by data bytes, or by both or none. Chip Select (CS#) must be driven High after the last bit of the instruction sequence has been shifted in. In the case of a Read Data Bytes (READ), Read Data Bytes at Higher Speed (Fast\_Read), Dual Output Fast Read (3Bh), Dual I/O Fast Read (BBh), Quad Input/Output FAST\_READ (EBh), Read Status Register (RDSR), Read Information Register (RDIFR) or Release from Deep Power-down, and Read Device ID (RDI) instruction, the shifted-in instruction sequence is followed by a data-out sequence. Chip Select (CS#) can be driven High after any bit of the data-out sequence is being shifted out.

In the case of a Page Program (PP), Sector Erase (SE), Block Erase (BE), Chip Erase (CE), Write Status Register (WRSR), Write Enable (WREN), Write Disable (WRDI) or Deep Power-down (DP) instruction, Chip Select (CS#) must be driven High exactly at a byte boundary, otherwise the instruction is rejected, and is not executed. That is, Chip Select (CS#) must be driven High when the number of clock pulses after Chip Select (CS#) being driven Low is an exact multiple of eight. For Page Program, if at any time the input byte is not a full byte, nothing will happen and WEL will not be reset.

**In the case of multi-byte commands of Page Program (PP), and Release from Deep Power Down (RES ) minimum number of bytes specified has to be given, without which, the command will be ignored.**

**In the case of Page Program, if the number of byte after the command is less than 4 (at least 1 data byte), it will be ignored too. In the case of SE and BE, exact 24-bit address is a must, any less or more will cause the command to be ignored.**

All attempts to access the memory array during a Write Status Register cycle, Program cycle or Erase cycle are ignored, and the internal Write Status Register cycle, Program cycle or Erase cycle continues unaffected.



Table 4A. Instruction Set

Instruction Name	Byte 1 Code	Byte 2	Byte 3	Byte 4	Byte 5	Byte 6	n-Bytes
EQPI	38h						
RSTQIO <sup>(2)</sup> Release Quad I/O or Fast Read Enhanced Mode	FFh						
RSTEN	66h						
RST <sup>(1)</sup>	99h						
Write Enable	06h						
Write Disable / Exit OTP mode	04h						
Read Status Register	05h	(S7-S0) <sup>(3)</sup>					continuous <sup>(4)</sup>
Write Status Register	01h	S7-S0					
Page Program	02h	A23-A16	A15-A8	A7-A0	D7-D0	Next byte	continuous
Sector Erase	20h	A23-A16	A15-A8	A7-A0			
Block Erase	D8h	A23-A16	A15-A8	A7-A0			
Chip Erase	C7h/ 60h						
Deep Power-down	B9h						
Release from Deep Power-down, and read Device ID	ABh	dummy	dummy	dummy	(ID7-ID0)		(5)
Release from Deep Power-down							
Manufacturer/ Device ID	90h	dummy	dummy	00h	(M7-M0)	(ID7-ID0)	(6)
				01h	(ID7-ID0)	(M7-M0)	
Read Identification	9Fh	(M7-M0)	(ID15-ID8)	(ID7-ID0)	(7)		
Enter OTP mode	3Ah						
Read SFDP mode and Unique ID Number	5Ah	A23-A16	A15-A8	A7-A0	dummy	(D7-D0)	(Next Byte) continuous

**Notes:**

- RST command only executed if RSTEN command is executed first. Any intervening command will disable Reset.
- Device accepts eight-clocks command in Standard SPI mode, or two-clocks command in Quad SPI mode
- Data bytes are shifted with Most Significant Bit first. Byte fields with data in parenthesis "( )" indicate data being read from the device on the DO pin
- The Status Register contents will repeat continuously until CS# terminate the instruction
- The Device ID will repeat continuously until CS# terminates the instruction
- The Manufacturer ID and Device ID bytes will repeat continuously until CS# terminates the instruction.  
00h on Byte 4 starts with MID and alternate with DID, 01h on Byte 4 starts with DID and alternate with MID
- (M7-M0) : Manufacturer, (ID15-ID8) : Memory Type, (ID7-ID0) : Memory Capacity



Table 4B. Instruction Set (Read Instruction)

Instruction Name	Byte 1 Code	Byte 2	Byte 3	Byte 4	Byte 5	Byte 6	n-Bytes
Read Data	03h	A23-A16	A15-A8	A7-A0	(D7-D0)	(Next byte)	continuous
Fast Read	0Bh	A23-A16	A15-A8	A7-A0	dummy	(D7-D0)	(Next Byte) continuous
Dual Output Fast Read	3Bh	A23-A16	A15-A8	A7-A0	dummy	(D7-D0, ...) <sup>(1)</sup>	(one byte per 4 clocks, continuous)
Dual I/O Fast Read	BBh	A23-A8 <sup>(2)</sup>	A7-A0, dummy <sup>(2)</sup>	(D7-D0, ...) <sup>(1)</sup>			(one byte per 4 clocks, continuous)
Quad I/O Fast Read	EBh	A23-A0, dummy <sup>(4)</sup>	(dummy, D7-D0) <sup>(5)</sup>	(D7-D0, ...) <sup>(3)</sup>			(one byte per 2 clocks, continuous)

**Notes:**

## 1. Dual Output data

DQ<sub>0</sub> = (D6, D4, D2, D0)DQ<sub>1</sub> = (D7, D5, D3, D1)

## 2. Dual Input Address

DQ<sub>0</sub> = A22, A20, A18, A16, A14, A12, A10, A8 ; A6, A4, A2, A0, dummy 6, dummy 4, dummy 2, dummy 0DQ<sub>1</sub> = A23, A21, A19, A17, A15, A13, A11, A9 ; A7, A5, A3, A1, dummy 7, dummy 5, dummy 3, dummy 1

## 3. Quad Data

DQ<sub>0</sub> = (D4, D0, ..... )DQ<sub>1</sub> = (D5, D1, ..... )DQ<sub>2</sub> = (D6, D2, ..... )DQ<sub>3</sub> = (D7, D3, ..... )

## 4. Quad Input Address

DQ<sub>0</sub> = A20, A16, A12, A8, A4, A0, dummy 4, dummy 0DQ<sub>1</sub> = A21, A17, A13, A9, A5, A1, dummy 5, dummy 1DQ<sub>2</sub> = A22, A18, A14, A10, A6, A2, dummy 6, dummy 2DQ<sub>3</sub> = A23, A19, A15, A11, A7, A3, dummy 7, dummy 3

## 5. Quad I/O Fast Read Data

DQ<sub>0</sub> = ( dummy 12, dummy 8, dummy 4, dummy 0, D4, D0 )DQ<sub>1</sub> = ( dummy 13, dummy 9, dummy 5, dummy 1, D5, D1 )DQ<sub>2</sub> = ( dummy 14, dummy 10, dummy 6, dummy 2, D6, D2 )DQ<sub>3</sub> = ( dummy 15, dummy 11, dummy 7, dummy 3, D7, D3 )

**Table 5. Manufacturer and Device Identification**

OP Code	(M7-M0)	(ID15-ID0)	(ID7-ID0)
ABh			14h
90h	1Ch		14h
9Fh	1Ch	7015h	

**Enable Quad Peripheral Interface mode (EQPI) (38h)**

The Enable Quad Peripheral Interface mode (EQPI) instruction will enable the flash device for Quad SPI bus operation. Upon completion of the instruction, all instructions thereafter will be 4-bit multiplexed input/output until a power cycle or “Reset Quad I/O instruction “ instruction, as shown in Figure 5. The device did not support the Read Data Bytes (READ) (03h), Dual Output Fast Read (3Bh) and Dual Input/Output FAST\_READ (BBh) modes while the Enable Quad Peripheral Interface mode (EQPI) (38h) turns on.

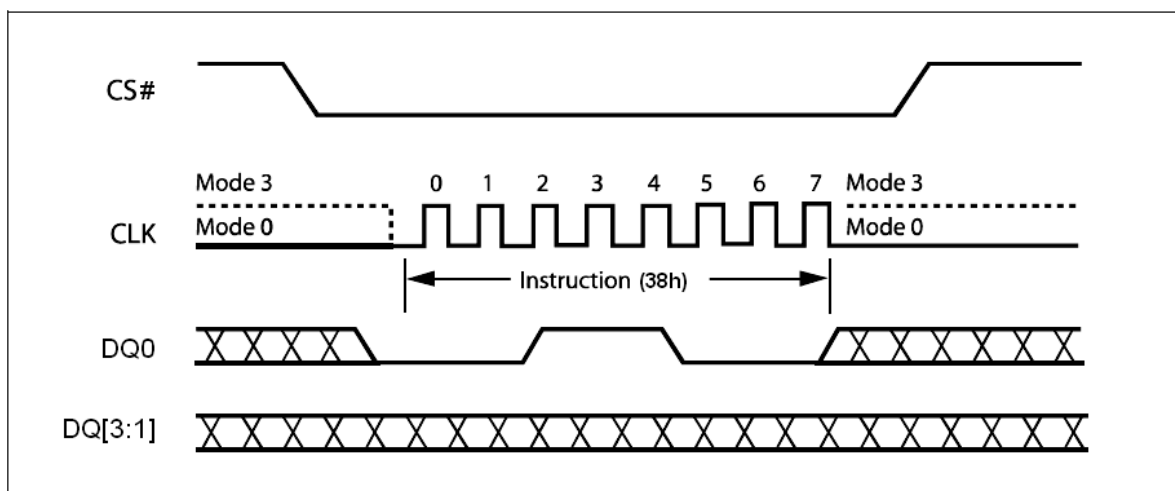
**Figure 5. Enable Quad Peripheral Interface mode Sequence Diagram**
**Reset Quad I/O (RSTQIO) or Release Quad I/O Fast Read Enhancement Mode (FFh)**

The Reset Quad I/O instruction resets the device to 1-bit Standard SPI operation. To execute a Reset Quad I/O operation, the host drives CS# low, sends the Reset Quad I/O command cycle (FFh) then, drives CS# high. This command can't be used in Standard SPI mode.

User also can use the 0xFFh command to release the Quad I/O Fast Read Enhancement Mode. The detail description, please see the Quad I/O Fast Read Enhancement Mode section.

**Note:**

If the system is in the Quad I/O Fast Read Enhance Mode under EQPI Mode, it is necessary to execute 0xFFh command by two times. The first 0xFFh command is to release Quad I/O Fast Read Enhance Mode, and the second 0xFFh command is to release EQPI Mode.

**Reset-Enable (RSTEN) (66h) and Reset (RST) (99h)**

The Reset operation is used as a system (software) reset that puts the device in normal operating Ready mode. This operation consists of two commands: Reset-Enable (RSTEN) and Reset (RST).

To reset the EN25QH16 the host drives CS# low, sends the Reset-Enable command (66h), and drives CS# high. Next, the host drives CS# low again, sends the Reset command (99h), and drives CS# high. The Reset operation requires the Reset-Enable command followed by the Reset command. Any command other than the Reset command after the Reset-Enable command will disable the Reset-Enable.

A successful command execution will reset the Status register and the Information register to data = 00h, see Figure 6 for SPI Mode and Figure 6.1 for EQPI Mode. A device reset during an active Program or Erase operation aborts the operation, which can cause the data of the targeted address range to be corrupted or lost. Depending on the prior operation, the reset timing may vary. Recovery from a Write operation requires more software latency time ( $t_{SR}$ ) than recovery from other operations.

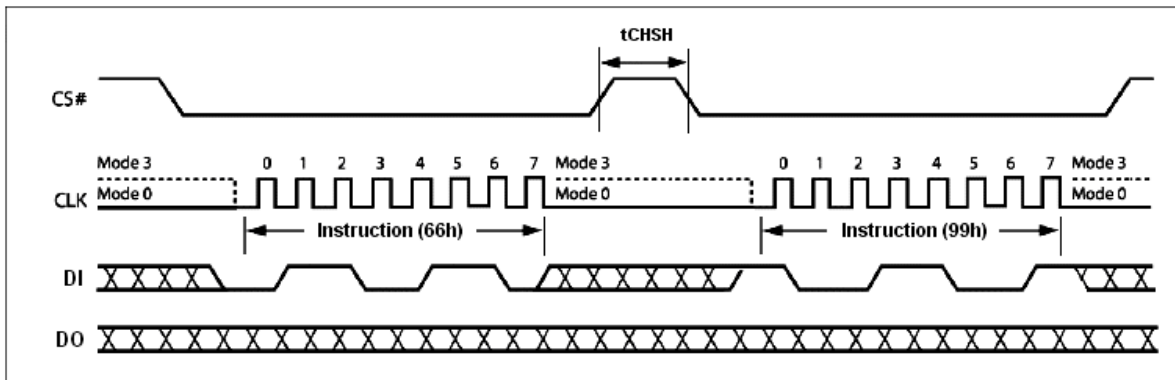

**Figure 6. Reset-Enable and Reset Sequence Diagram**

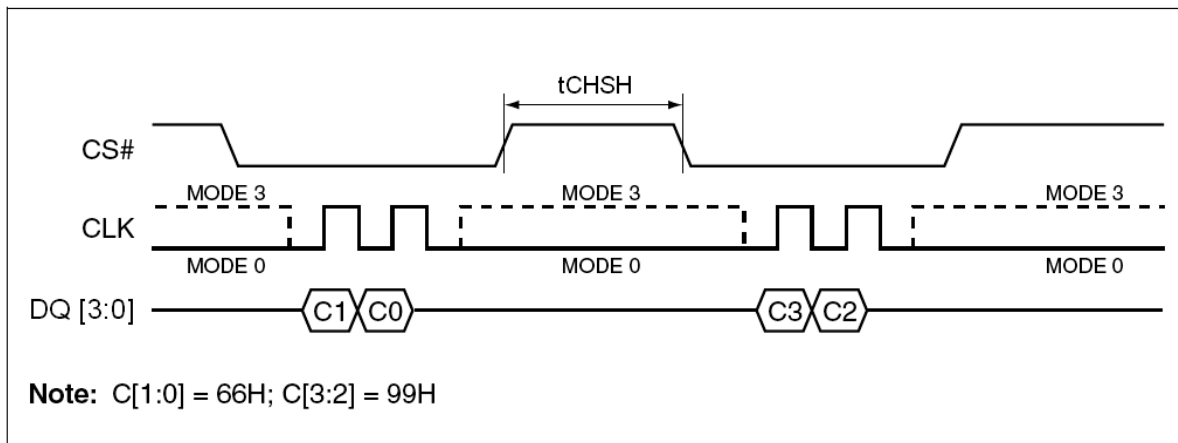

**Figure 6.1 Reset-Enable and Reset Sequence Diagram under EQPI Mode**

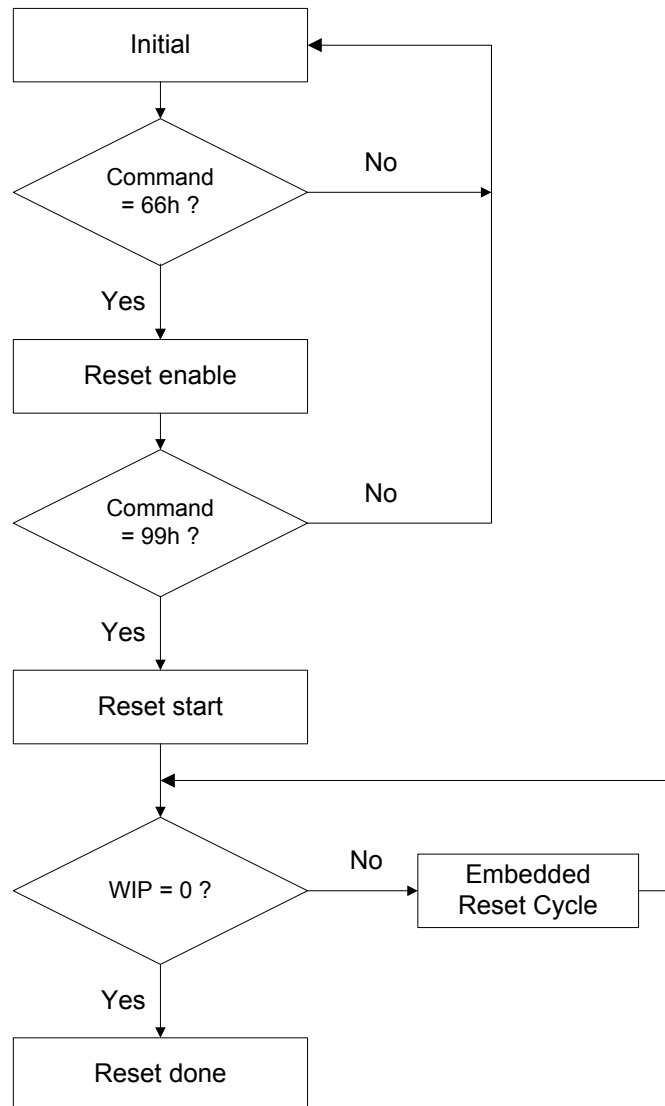
**Software Reset Flow**

**Note:**

1. Reset-Enable (RSTEN) (66h) and Reset (RST) (99h) commands need to match standard SPI or EQPI (Quad) mode.
2. Continue (Enhance) EB mode need to use quad Reset-Enable (RSTEN) (66h) and quad Reset (RST) (99h) commands.
3. If user is not sure it is in SPI or Quad mode, we suggest to execute sequence as follows:  
Quad Reset-Enable (RSTEN) (66h) -> Quad Reset (RST) (99h) -> SPI Reset-Enable (RSTEN) (66h)  
-> SPI Reset (RST) (99h) to reset.
4. The reset command could be executed during embedded program and erase process, EQPI mode and Continue EB mode to back to SPI mode.
5. This flow cannot release the device from Deep power down mode.
6. The Status Register Bit and Information register Bit will reset to default value after reset done.
7. If user reset device during erase, the embedded reset cycle software reset latency will take about 28us in worst case.

**Write Enable (WREN) (06h)**

The Write Enable (WREN) instruction (Figure 7) sets the Write Enable Latch (WEL) bit. The Write Enable Latch (WEL) bit must be set prior to every Page Program (PP), Sector Erase (SE), Block Erase (BE), Chip Erase (CE) and Write Status Register (WRSR) instruction.

The Write Enable (WREN) instruction is entered by driving Chip Select (CS#) Low, sending the instruction code, and then driving Chip Select (CS#) High.

The instruction sequence is shown in Figure 8.1 while using the Enable Quad Peripheral Interface mode (EQPI) (38h) command.

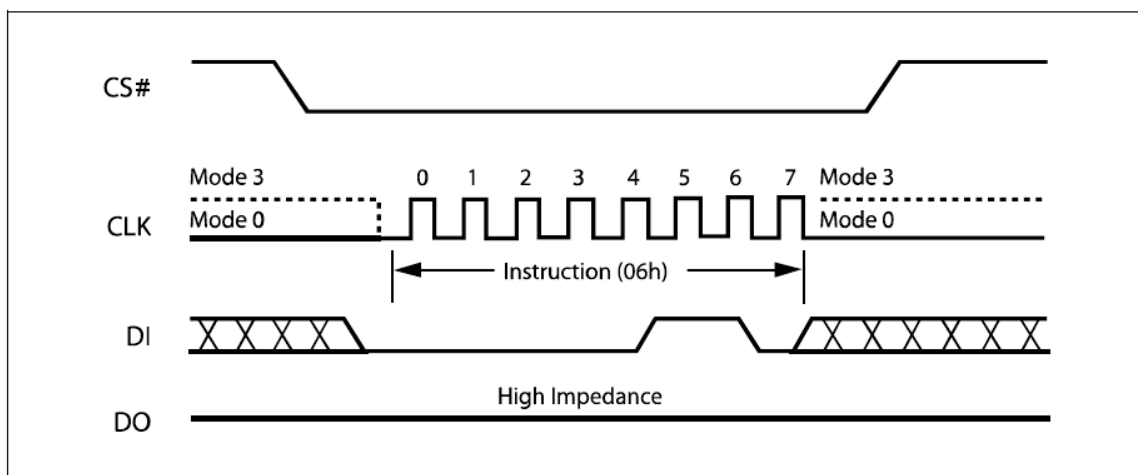
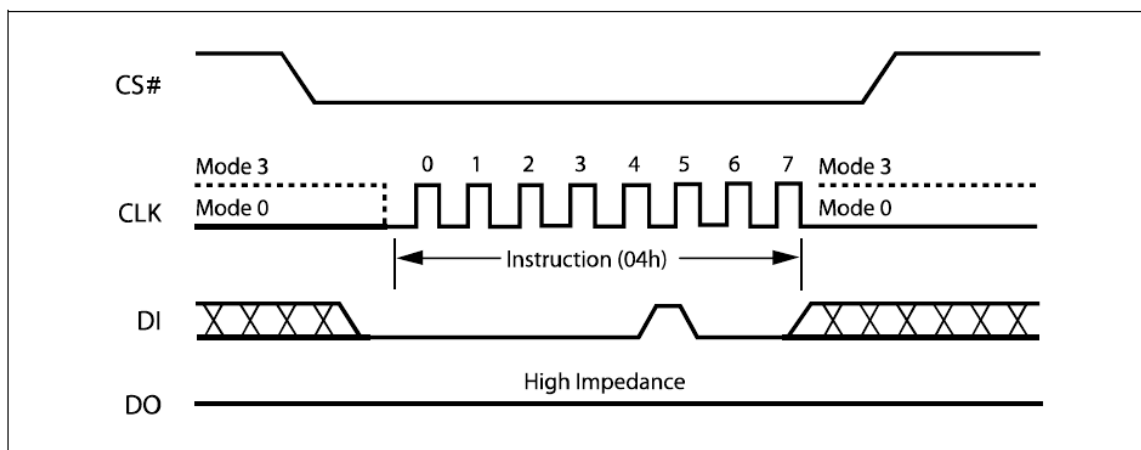

**Figure 7. Write Enable Instruction Sequence Diagram**

**Write Disable (WRDI) (04h)**

The Write Disable instruction (Figure 8) resets the Write Enable Latch (WEL) bit in the Status Register to a 0 or exit from OTP mode to normal mode. The Write Disable instruction is entered by driving Chip Select (CS#) low, shifting the instruction code "04h" into the DI pin and then driving Chip Select (CS#) high. Note that the WEL bit is automatically reset after Power-up and upon completion of the Write Status Register, Page Program, Sector Erase, Block Erase (BE) and Chip Erase instructions.

The instruction sequence is shown in Figure 8.1 while using the Enable Quad Peripheral Interface mode (EQPI) (38h) command.

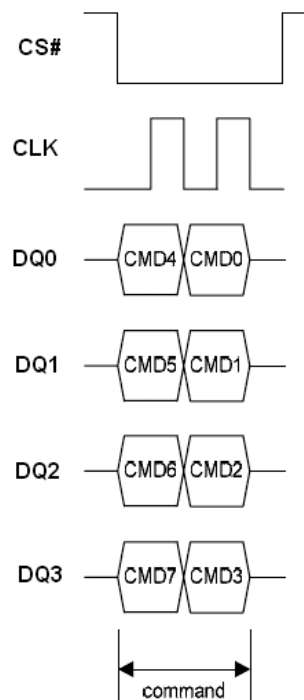
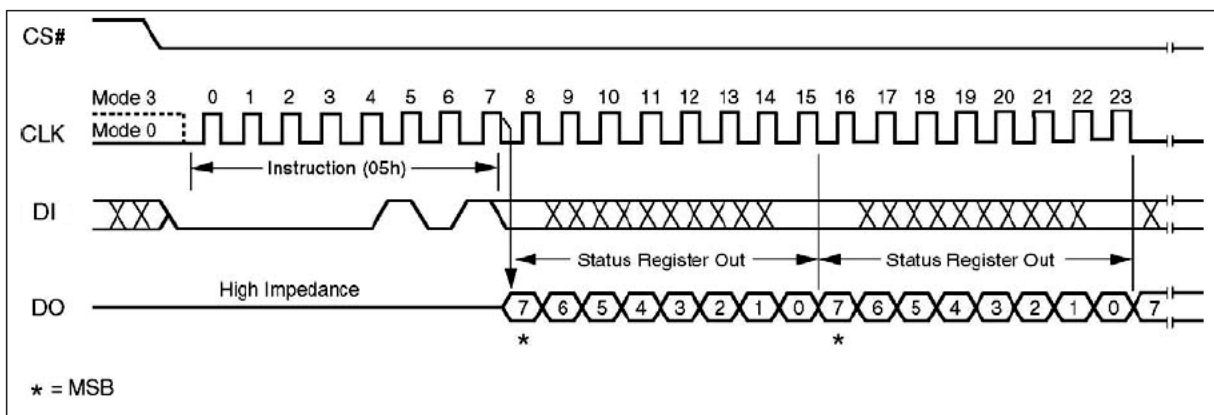

**Figure 8. Write Disable Instruction Sequence Diagram**

**Figure 8.1 Write Enable/Disable Instruction Sequence under EQPI Mode**
**Read Status Register (RDSR) (05h)**

The Read Status Register (RDSR) instruction allows the Status Register to be read. The Status Register may be read at any time, even while a Program, Erase or Write Status Register cycle is in progress. When one of these cycles is in progress, it is recommended to check the Write In Progress (WIP) bit before sending a new instruction to the device. It is also possible to read the Status Register continuously, as shown in Figure 9.

The instruction sequence is shown in Figure 9.1 while using the Enable Quad Peripheral Interface mode (EQPI) (38h) command.

**Figure 9. Read Status Register Instruction Sequence Diagram**

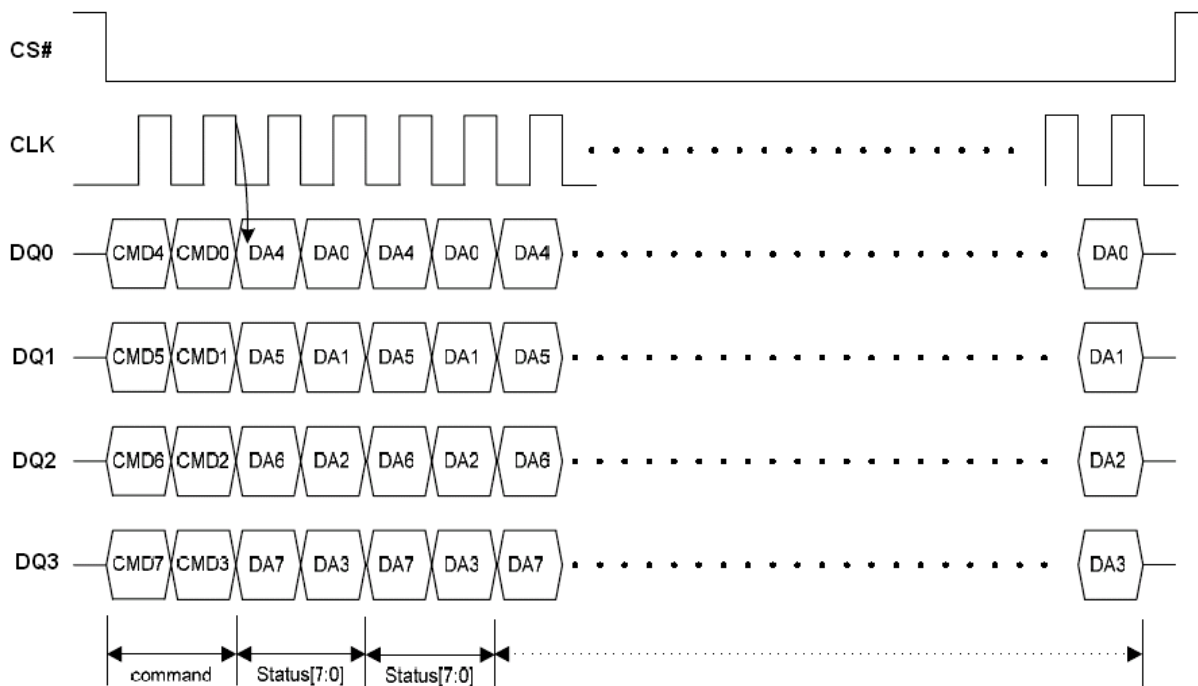
**Figure 9.1 Read Status Register Instruction Sequence under EQPI Mode**
**Table 6. Status Register Bit Locations**

S7		S6	S5	S4	S3	S2	S1	S0
SRP Status Register Protect	OTP_LOCK bit (note 1)	WHDIS WP# & Hold# Disable bit	BP3 (Block Protected bits)	BP2 (Block Protected bits)	BP1 (Block Protected bits)	BP0 (Block Protected bits)	WEL (Write Enable Latch)	WIP (Write In Progress bit) (Note 3)
1 = status register write disable	1 = OTP sector is protected	1 = WP# and HOLD# disable 0 = WP# and HOLD# enable	(note 2)	(note 2)	(note 2)	(note 2)	1 = write enable 0 = not write enable	1 = write operation 0 = not in write operation
Non-volatile bit		Non-volatile bit	Non-volatile bit	Non-volatile bit	Non-volatile bit	Non-volatile bit	volatile bit	volatile bit

**Note**

1. In OTP mode, SRP bit is served as OTP\_LOCK bit.
2. See the table "Protected Area Sizes Sector Organization".

The status and control bits of the Status Register are as follows:

**WIP bit.** The Write In Progress (WIP) bit indicates whether the memory is busy with a Write Status Register, Program or Erase cycle. When set to 1, such a cycle is in progress, when reset to 0 no such cycle is in progress.

**WEL bit.** The Write Enable Latch (WEL) bit indicates the status of the internal Write Enable Latch. When set to 1 the internal Write Enable Latch is set, when set to 0 the internal Write Enable Latch is reset and no Write Status Register, Program or Erase instruction is accepted.

**BP3, BP2, BP1, BP0 bits.** The Block Protect (BP3, BP2, BP1, BP0) bits are non-volatile. They define the size of the area to be software protected against Program and Erase instructions. These bits are written with the Write Status Register (WRSR) instruction. When one or both of the Block Protect (BP3, BP2, BP1, BP0) bits is set to 1, the relevant memory area (as defined in Table 3.) becomes protected against Page Program (PP) Sector Erase (SE) and , Block Erase (BE), instructions. The Block Protect (BP3, BP2, BP1, BP0) bits can be written provided that the Hardware Protected mode has not been set.



The Chip Erase (CE) instruction is executed if, and only if, all Block Protect (BP3, BP2, BP1, BP0) bits are 0.

**WHDIS bit.** The WP# and Hold# Disable bit (WHDIS bit), non-volatile bit, it indicates the WP# and HOLD# are enabled or not. When it is “0” (factory default), the WP# and HOLD# are enabled. On the other hand, while WHDIS bit is “1”, the WP# and HOLD# are disabled. If the system executes Quad Input/Output FAST\_READ (EBh) or EQPI (38h) command, this WHDIS bit becomes no affection since WP# and HOLD# function will be disabled by Quad Input/Output FAST\_READ (EBh) or EQPI mode.

**SRP bit / OTP\_LOCK bit.** The Status Register Protect (SRP) bit operates in conjunction with the Write Protect (WP#) signal. The Status Register Write Protect (SRP) bit and Write Protect (WP#) signal allow the device to be put in the Hardware Protected mode (when the Status Register Protect (SRP) bit is set to 1, and Write Protect (WP#) is driven Low). In this mode, the non-volatile bits of the Status Register (SRP, BP3, BP2, BP1, BP0) become read-only bits and the Write Status Register (WRSR) instruction is no longer accepted for execution.

In OTP mode, this bit serves as OTP\_LOCK bit, user can read/program/erase OTP sector as normal sector while OTP\_LOCK bit value is equal 0, after OTP\_LOCK bit is programmed with 1 by WRSR command, the OTP sector is protected from program and erase operation. The OTP\_LOCK bit can only be programmed once.

**Note :** In OTP mode, the WRSR command will ignore any input data and program OTP\_LOCK bit to 1, user must clear the protect bits before enter OTP mode and program the OTP code, then execute WRSR command to lock the OTP sector before leaving OTP mode.

#### **Write Status Register (WRSR) (01h)**

The Write Status Register (WRSR) instruction allows new values to be written to the Status Register. Before it can be accepted, a Write Enable (WREN) instruction must previously have been executed. After the Write Enable (WREN) instruction has been decoded and executed, the device sets the Write Enable Latch (WEL).

The Write Status Register (WRSR) instruction is entered by driving Chip Select (CS#) Low, followed by the instruction code and the data byte on Serial Data Input (DI).

The instruction sequence is shown in Figure 10. The Write Status Register (WRSR) instruction has no effect on S1 and S0 of the Status Register. Chip Select (CS#) must be driven High after the eighth bit of the data byte has been latched in. If not, the Write Status Register (WRSR) instruction is not executed. As soon as Chip Select (CS#) is driven High, the self-timed Write Status Register cycle (whose duration is  $t_w$ ) is initiated. While the Write Status Register cycle is in progress, the Status Register may still be read to check the value of the Write In Progress (WIP) bit. The Write In Progress (WIP) bit is 1 during the self-timed Write Status Register cycle, and is 0 when it is completed. When the cycle is completed, the Write Enable Latch (WEL) is reset.

The Write Status Register (WRSR) instruction allows the user to change the values of the Block Protect (BP3, BP2, BP1, BP0) bits, to define the size of the area that is to be treated as read-only, as defined in Table 3. The Write Status Register (WRSR) instruction also allows the user to set or reset the Status Register Protect (SRP) bit in accordance with the Write Protect (WP#) signal. The Status Register Protect (SRP) bit and Write Protect (WP#) signal allow the device to be put in the Hardware Protected Mode (HPM). The Write Status Register (WRSR) instruction is not executed once the Hardware Protected Mode (HPM) is entered.

The instruction sequence is shown in Figure 10.1 while using the Enable Quad Peripheral Interface mode (EQPI) (38h) command.

**NOTE :** In the OTP mode, WRSR command will ignore input data and program OTP\_LOCK bit to 1.

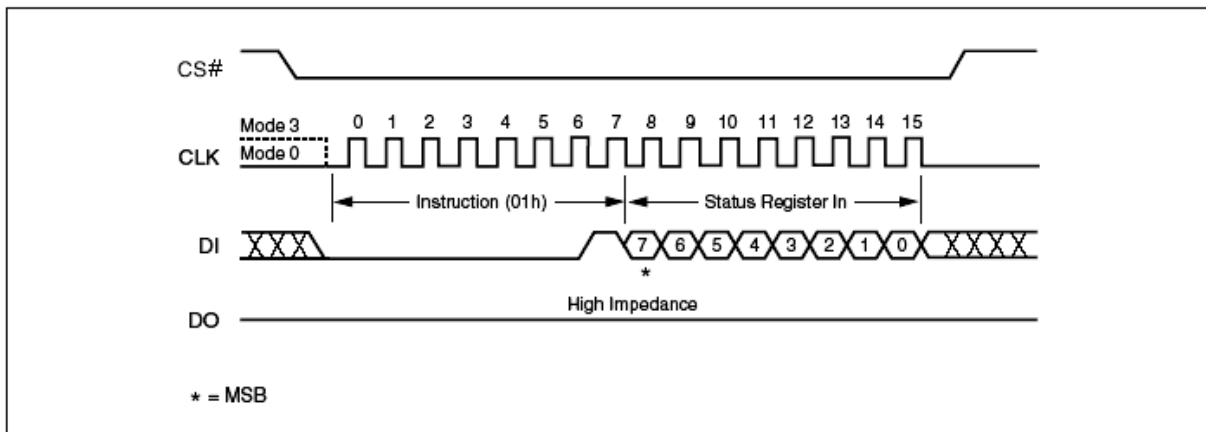
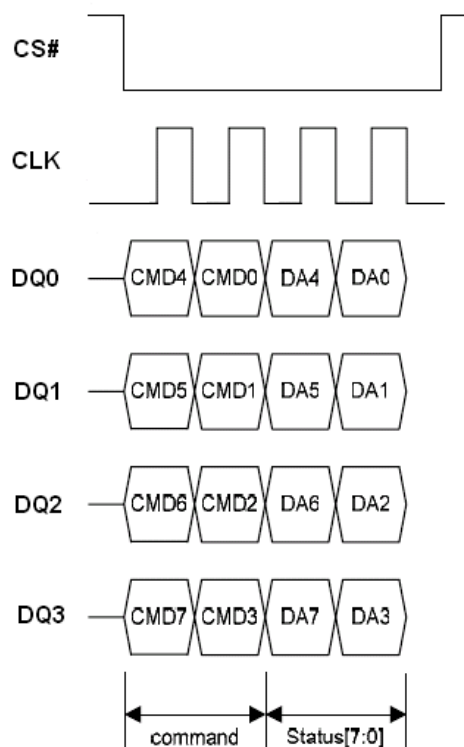
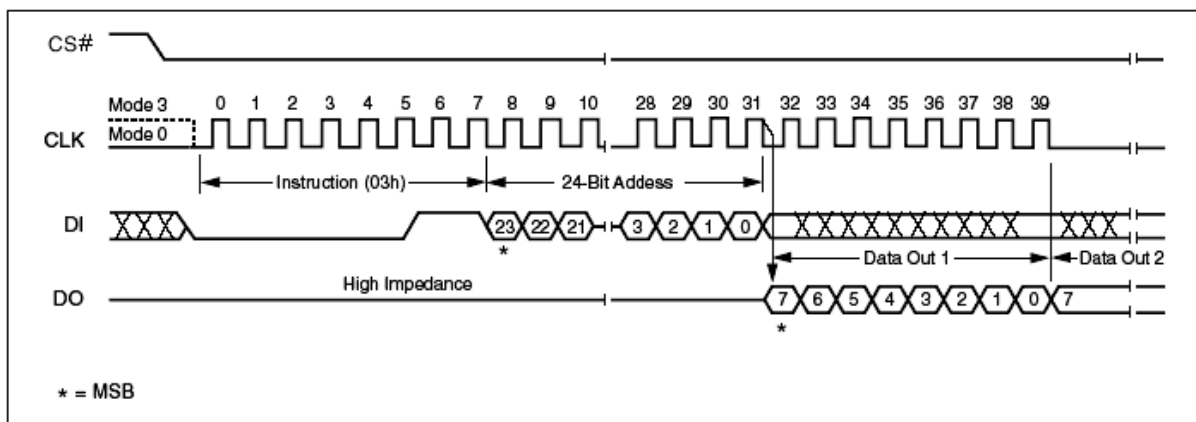

**Figure 10. Write Status Register Instruction Sequence Diagram**

**Figure 10.1 Write Status Register Instruction Sequence under EQPI Mode**

**Read Data Bytes (READ) (03h)**

The device is first selected by driving Chip Select (CS#) Low. The instruction code for the Read Data Bytes (READ) instruction is followed by a 3-byte address (A23-A0), each bit being latched-in during the rising edge of Serial Clock (CLK). Then the memory contents, at that address, is shifted out on Serial Data Output (DO), each bit being shifted out, at a maximum frequency  $f_R$ , during the falling edge of Serial Clock (CLK).

The instruction sequence is shown in Figure 11. The first byte addresses can be at any location. The address is automatically incremented to the next higher address after each byte of data is shifted out. The whole memory can, therefore, be read with a single Read Data Bytes (READ) instruction. When the highest address is reached, the address counter rolls over to 000000h, allowing the read sequence to be continued indefinitely.

The Read Data Bytes (READ) instruction is terminated by driving Chip Select (CS#) High. Chip Select (CS#) can be driven High at any time during data output. Any Read Data Bytes (READ) instruction, while an Erase, Program or Write cycle is in progress, is rejected without having any effects on the cycle that is in progress.



**Figure 11. Read Data Instruction Sequence Diagram**

**Read Data Bytes at Higher Speed (FAST\_READ) (0Bh)**

The device is first selected by driving Chip Select (CS#) Low. The instruction code for the Read Data Bytes at Higher Speed (FAST\_READ) instruction is followed by a 3-byte address (A23-A0) and a dummy byte, each bit being latched-in during the rising edge of Serial Clock (CLK). Then the memory contents, at that address, is shifted out on Serial Data Output (DO), each bit being shifted out, at a maximum frequency  $F_R$ , during the falling edge of Serial Clock (CLK).

The instruction sequence is shown in Figure 12. The first byte addressed can be at any location. The address is automatically incremented to the next higher address after each byte of data is shifted out. The whole memory can, therefore, be read with a single Read Data Bytes at Higher Speed (FAST\_READ) instruction. When the highest address is reached, the address counter rolls over to 000000h, allowing the read sequence to be continued indefinitely.

The Read Data Bytes at Higher Speed (FAST\_READ) instruction is terminated by driving Chip Select (CS#) High. Chip Select (CS#) can be driven High at any time during data output. Any Read Data Bytes at Higher Speed (FAST\_READ) instruction, while an Erase, Program or Write cycle is in progress, is rejected without having any effects on the cycle that is in progress.

The instruction sequence is shown in Figure 12.1 while using the Enable Quad Peripheral Interface mode (EQPI) (38h) command.

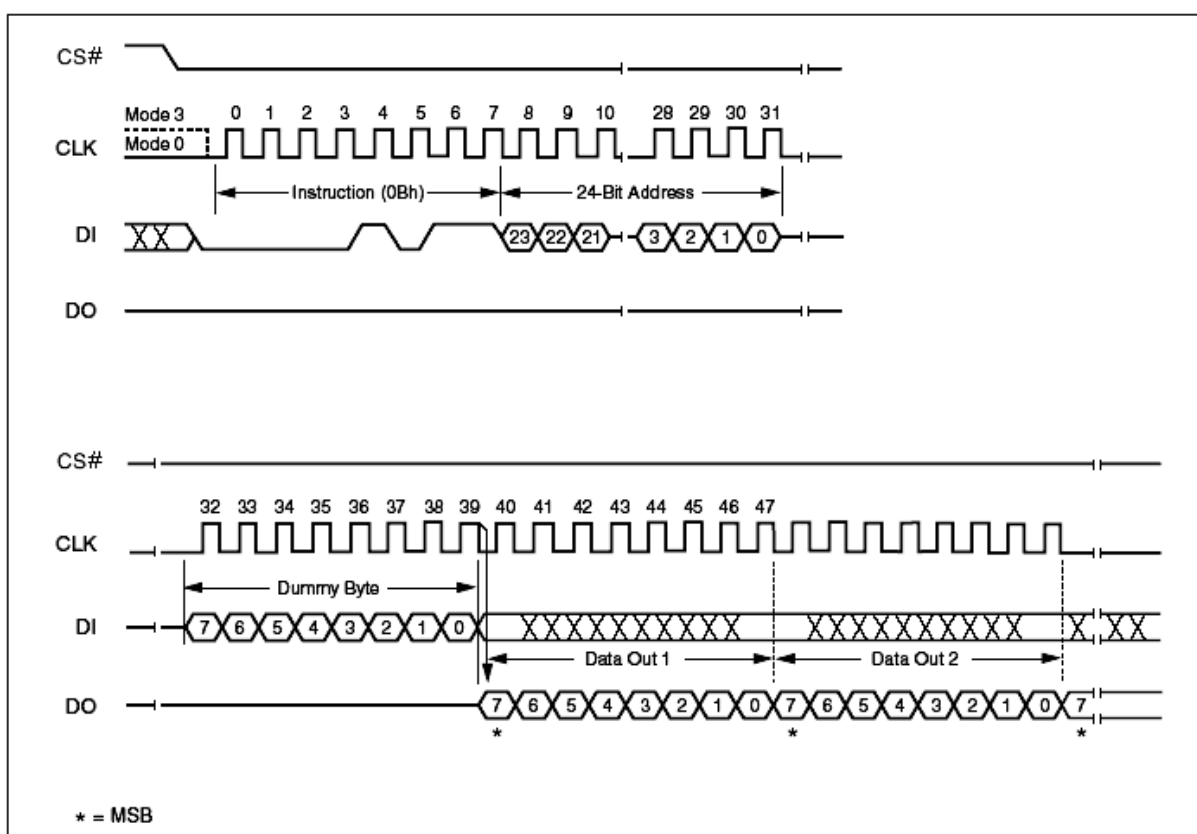

**Figure 12. Fast Read Instruction Sequence Diagram**

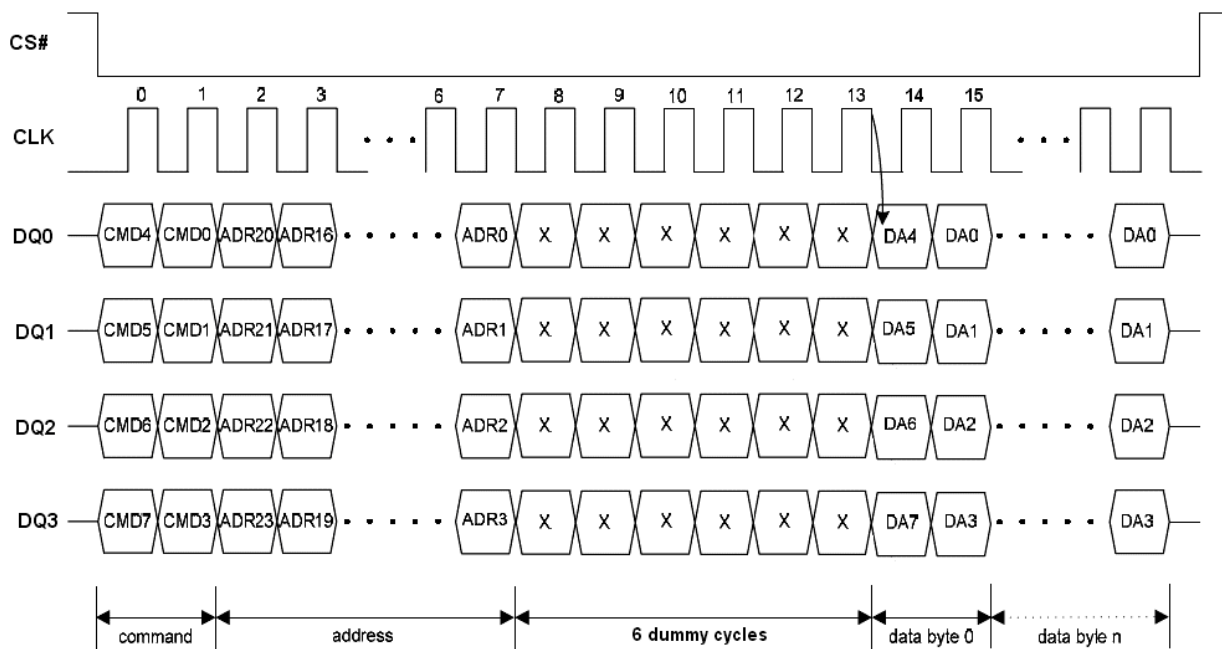
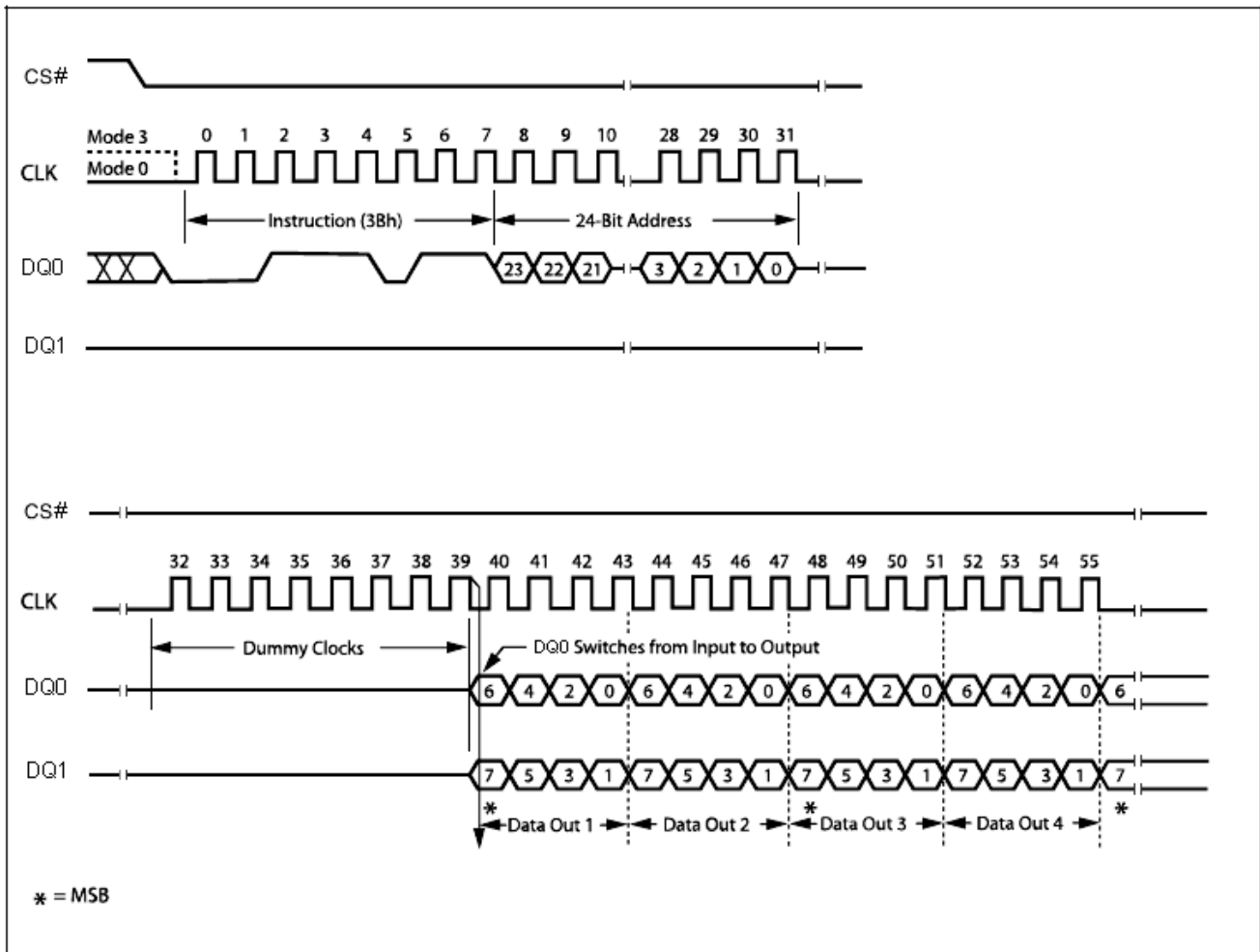

**Figure 12.1 Fast Read Instruction Sequence under EQPI Mode**

### Dual Output Fast Read (3Bh)

The Dual Output Fast Read (3Bh) is similar to the standard Fast Read (0Bh) instruction except that data is output on two pins, DQ<sub>0</sub> and DQ<sub>1</sub>, instead of just DQ<sub>0</sub>. This allows data to be transferred from the EN25QH16 at twice the rate of standard SPI devices. The Dual Output Fast Read instruction is ideal for quickly downloading code from RAM upon power-up or for applications that cache code-segments to RAM for execution.

Similar to the Fast Read instruction, the Dual Output Fast Read instruction can operate at the highest possible frequency of FR (see AC Electrical Characteristics). This is accomplished by adding eight “dummy clocks after the 24-bit address as shown in Figure 13. The dummy clocks allow the device’s internal circuits additional time for setting up the initial address. The input data during the dummy clock is “don’t care”. However, the DI pin should be high-impedance prior to the falling edge of the first data out clock.

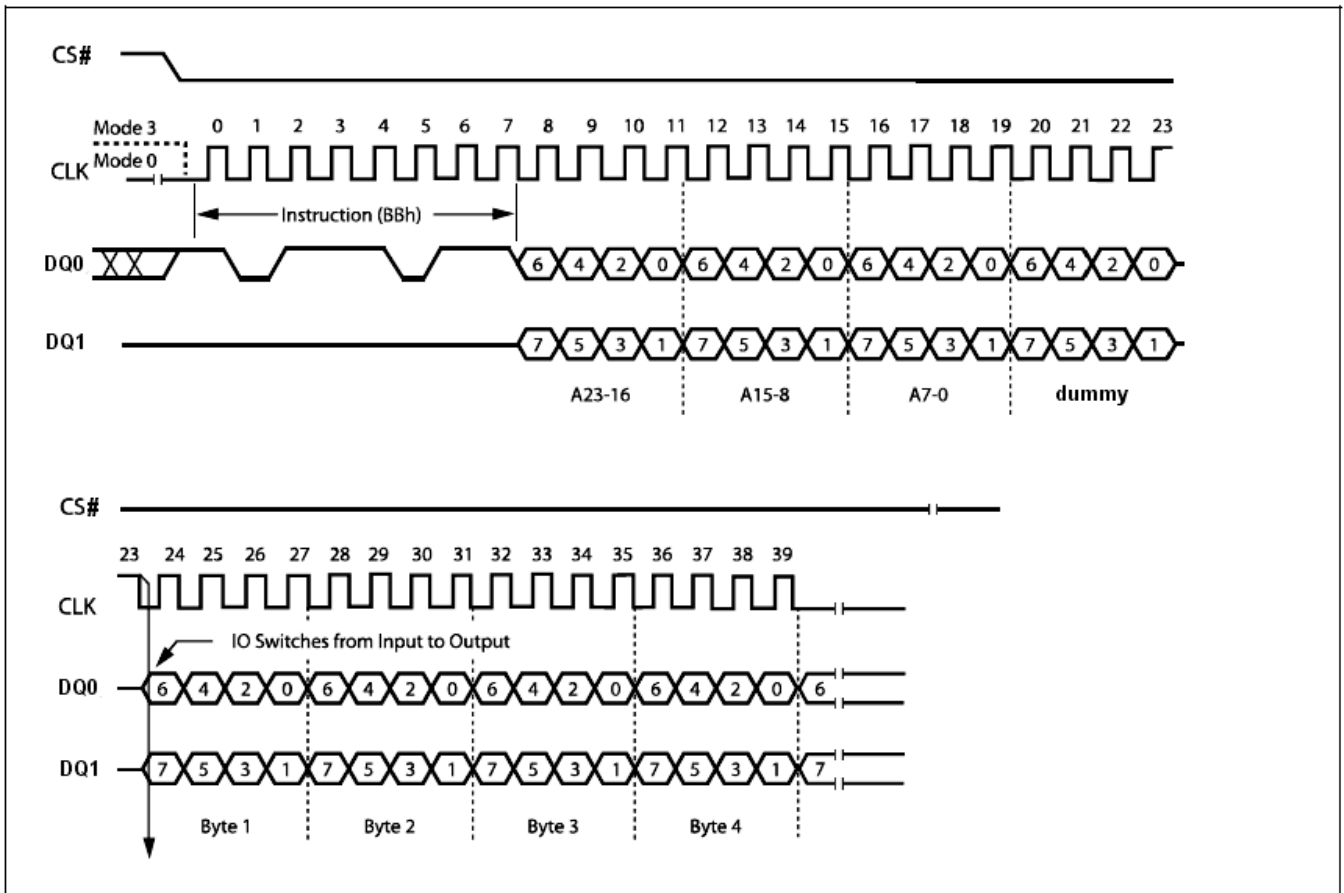

**Figure 13. Dual Output Fast Read Instruction Sequence Diagram**

**Dual Input / Output FAST\_READ (BBh)**

The Dual I/O Fast Read (BBh) instruction allows for improved random access while maintaining two I/O pins, DQ<sub>0</sub> and DQ<sub>1</sub>. It is similar to the Dual Output Fast Read (3Bh) instruction but with the capability to input the Address bits (A23-A0) two bits per clock. This reduced instruction overhead may allow for code execution (XIP) directly from the Dual SPI in some applications.

The Dual I/O Fast Read instruction enable double throughput of Serial Flash in read mode. The address is latched on rising edge of CLK, and data of every two bits (interleave 2 I/O pins) shift out on the falling edge of CLK at a maximum frequency. The first address can be at any location. The address is automatically increased to the next higher address after each byte data is shifted out, so the whole memory can be read out at a single Dual I/O Fast Read instruction. The address counter rolls over to 0 when the highest address has been reached. Once writing Dual I/O Fast Read instruction, the following address/dummy/data out will perform as 2-bit instead of previous 1-bit, as shown in Figure 14.



**Figure 14. Dual Input / Output Fast Read Instruction Sequence Diagram**

**Quad Input / Output FAST\_READ (EBh)**

The Quad Input/Output FAST\_READ (EBh) instruction is similar to the Dual I/O Fast Read (BBh) instruction except that address and data bits are input and output through four pins, DQ<sub>0</sub>, DQ<sub>1</sub>, DQ<sub>2</sub> and DQ<sub>3</sub> and six dummy clocks are required prior to the data output. The Quad I/O dramatically reduces instruction overhead allowing faster random access for code execution (XIP) directly from the Quad SPI. The Quad Input/Output FAST\_READ (EBh) instruction enable quad throughput of Serial Flash in read mode.

The address is latching on rising edge of CLK, and data of every four bits (interleave on 4 I/O pins) shift out on the falling edge of CLK at a maximum frequency F<sub>R</sub>. The first address can be any location. The address is automatically increased to the next higher address after each byte data is shifted out, so the whole memory can be read out at a single Quad Input/Output FAST\_READ instruction. The address counter rolls over to 0 when the highest address has been reached. Once writing Quad Input/Output FAST\_READ instruction, the following address/dummy/data out will perform as 4-bit instead of previous 1-bit.

The sequence of issuing Quad Input/Output FAST\_READ (EBh) instruction is: CS# goes low -> sending Quad Input/Output FAST\_READ (EBh) instruction -> 24-bit address interleave on DQ<sub>3</sub>, DQ<sub>2</sub>, DQ<sub>1</sub> and DQ<sub>0</sub> -> 6 dummy cycles -> data out interleave on DQ<sub>3</sub>, DQ<sub>2</sub>, DQ<sub>1</sub> and DQ<sub>0</sub> -> to end Quad Input/Output FAST\_READ (EBh) operation can use CS# to high at any time during data out, as shown in Figure 15.

The instruction sequence is shown in Figure 15.1 while using the Enable Quad Peripheral Interface mode (EQPI) (38h) command.

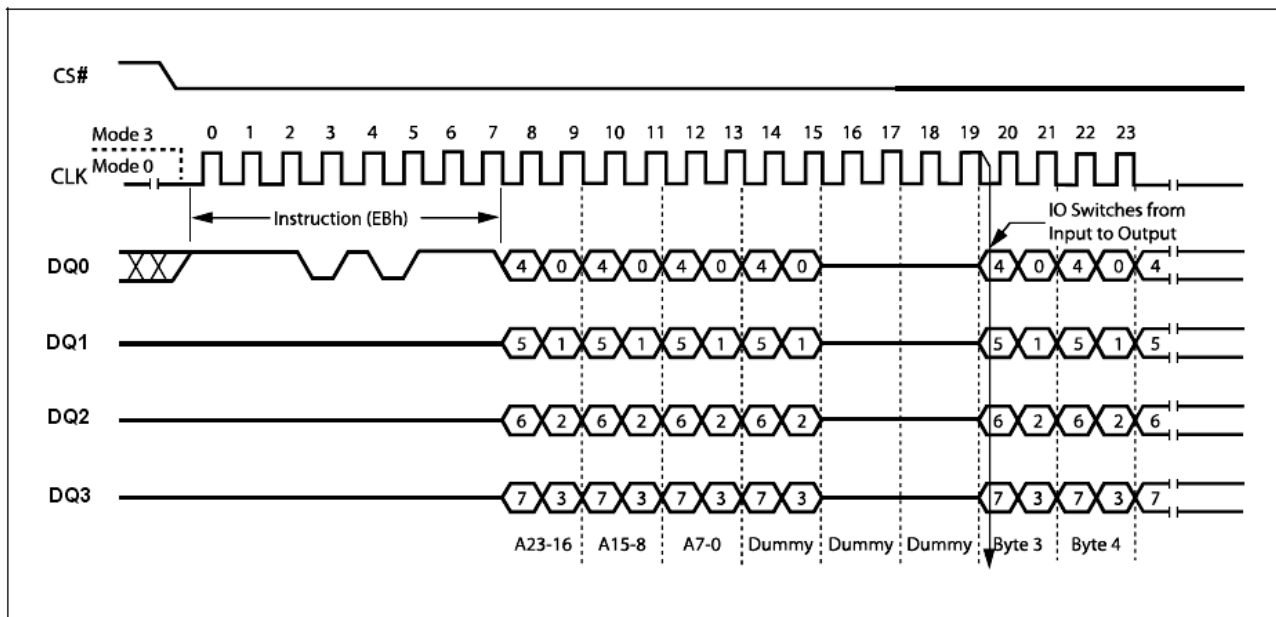

**Figure 15. Quad Input / Output Fast Read Instruction Sequence Diagram**

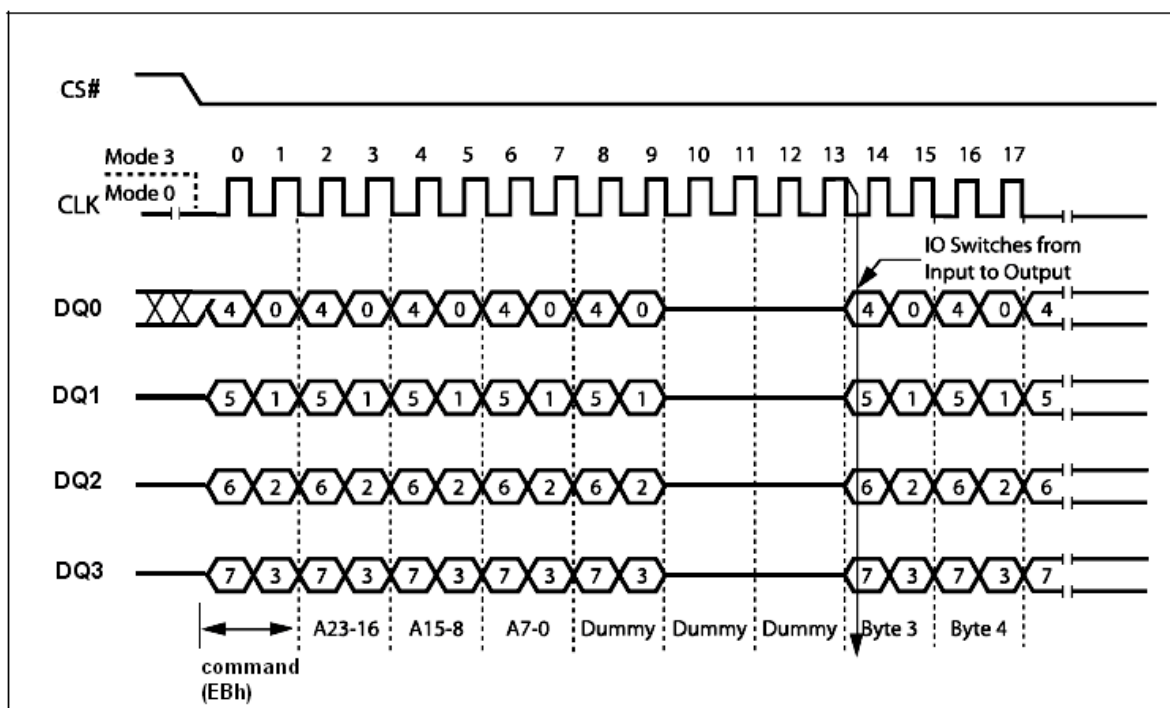

**Figure 15.1. Quad Input / Output Fast Read Instruction Sequence under EQPI Mode**

Another sequence of issuing Quad Input/Output FAST\_READ (EBh) instruction especially useful in random access is : CS# goes low -> sending Quad Input/Output FAST\_READ (EBh) instruction -> 24-bit address interleave on DQ<sub>3</sub>, DQ<sub>2</sub>, DQ<sub>1</sub> and DQ<sub>0</sub> -> performance enhance toggling bit P[7:0] -> 4 dummy cycles -> data out interleave on DQ<sub>3</sub>, DQ<sub>2</sub>, DQ<sub>1</sub> and DQ<sub>0</sub> till CS# goes high -> CS# goes low (reduce Quad Input/Output FAST\_READ (EBh) instruction) -> 24-bit access address, as shown in Figure 16.

In the performance – enhancing mode, P[7:4] must be toggling with P[3:0] ; likewise P[7:0] = A5h, 5Ah, F0h or 0Fh can make this mode continue and reduce the next Quad Input/Output FAST\_READ (EBh) instruction. Once P[7:4] is no longer toggling with P[3:0] ; likewise P[7:0] = FFh, 00h, AAh or 55h. These commands will reset the performance enhance mode. And afterwards CS# is raised or issuing FF command (CS# goes high -> CS# goes low -> sending 0xFFh -> CS# goes high) instead of no toggling, the system then will escape from performance enhance mode and return to normal operation.

While Program/ Erase/ Write Status Register is in progress, Quad Input/Output FAST\_READ (EBh) instruction is rejected without impact on the Program/ Erase/ Write Status Register current cycle.

The instruction sequence is shown in Figure 16.1 while using the Enable Quad Peripheral Interface mode (EQPI) (38h) command.

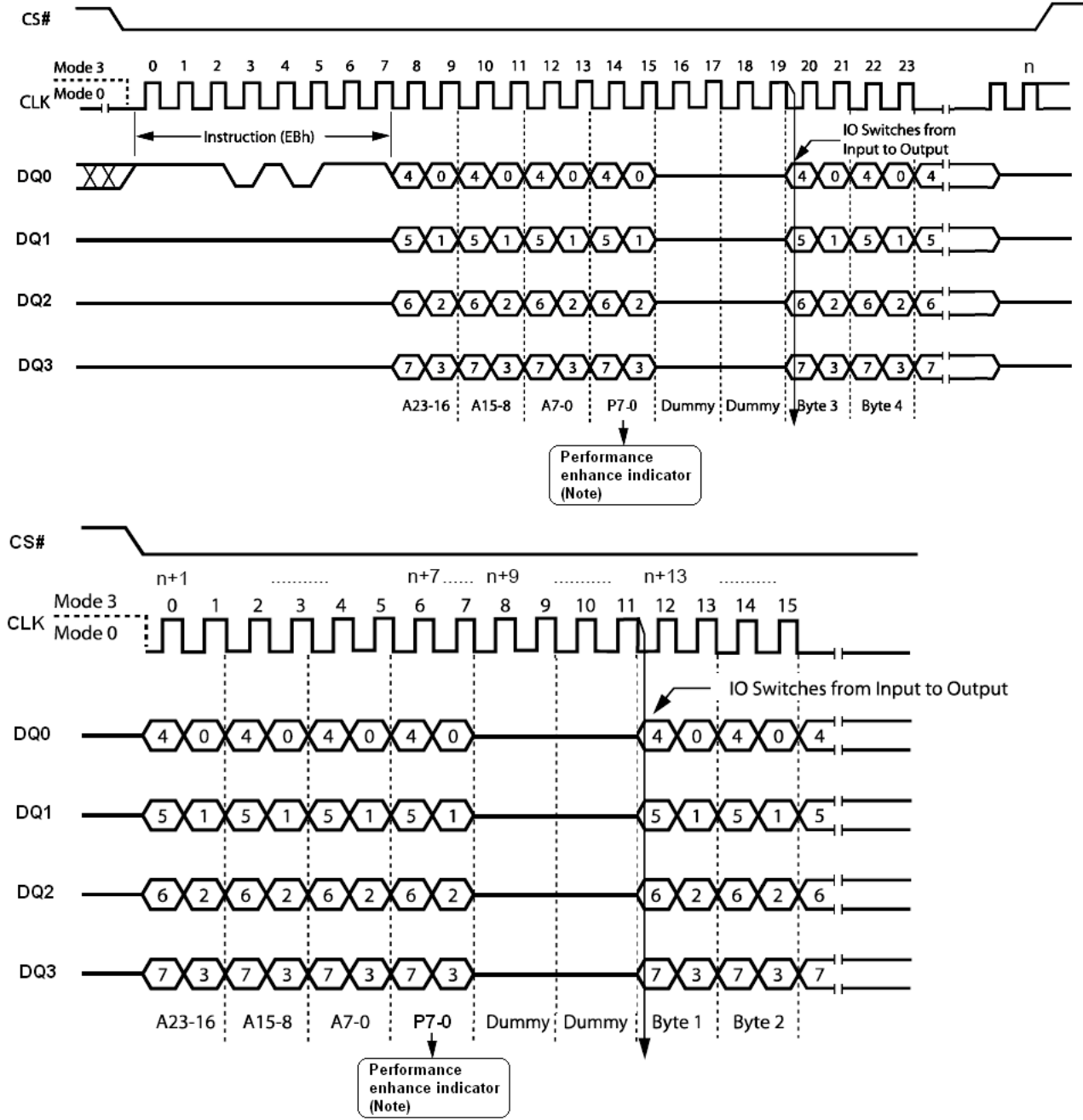

Note: Performance enhance mode, if P7 ≠ P3 & P6 ≠ P2 & P5 ≠ P1 & P4 ≠ P0 (Toggling), ex: A5, 5A, 0F  
 Reset the performance enhance mode, if P7 = P3 or P6 = P2 or P5 = P1 or P4 = P0, ex: AA, 00, FF

**Figure 16. Quad Input/Output Fast Read Enhance Performance Mode Sequence Diagram**

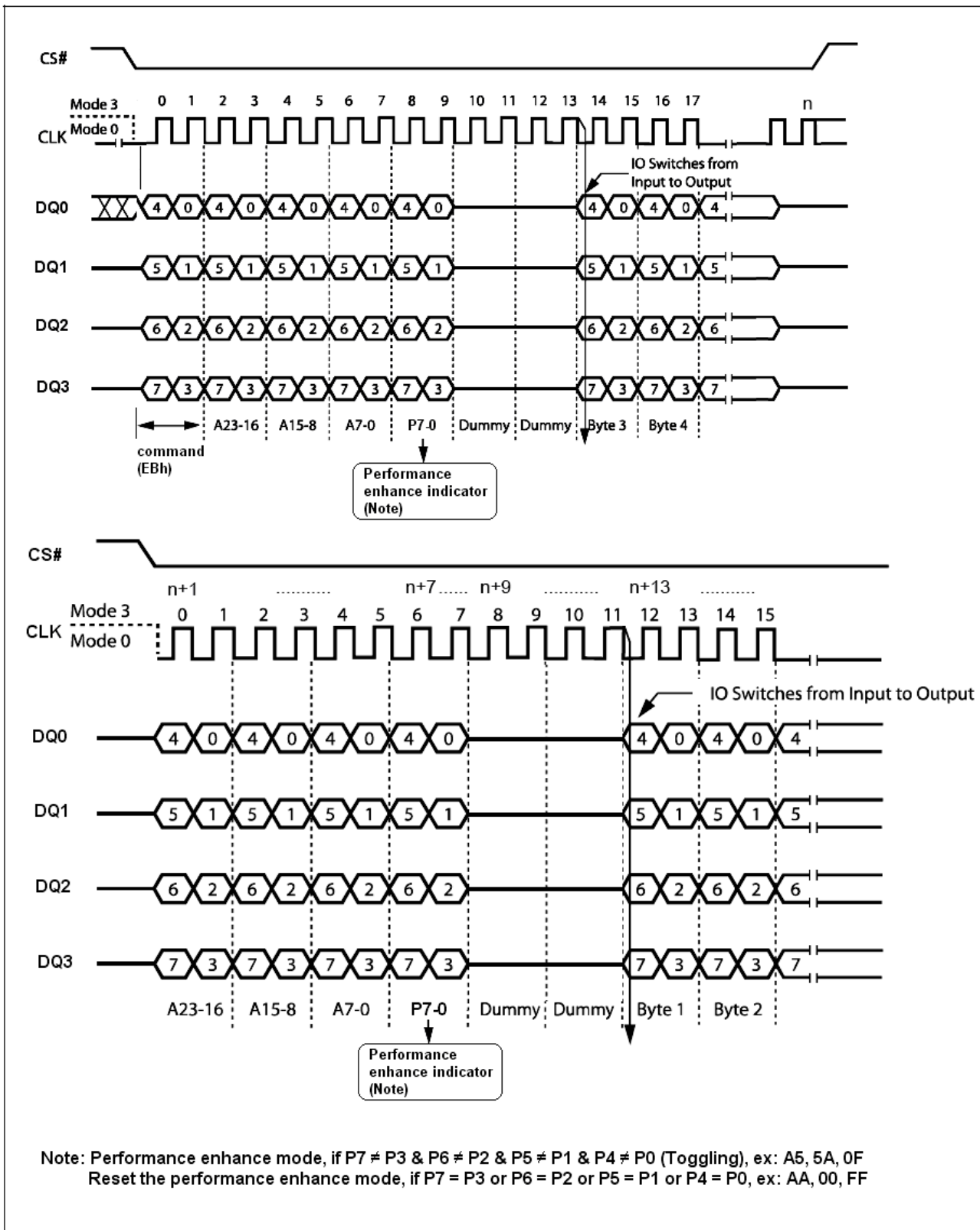
**Figure 16.1 Quad Input/Output Fast Read Enhance Performance Mode Sequence under EQPI Mode**

**Page Program (PP) (02h)**

The Page Program (PP) instruction allows bytes to be programmed in the memory. Before it can be accepted, a Write Enable (WREN) instruction must previously have been executed. After the Write Enable (WREN) instruction has been decoded, the device sets the Write Enable Latch (WEL).

The Page Program (PP) instruction is entered by driving Chip Select (CS#) Low, followed by the instruction code, three address bytes and at least one data byte on Serial Data Input (DI). If the 8 least significant address bits (A7-A0) are not all zero, all transmitted data that goes beyond the end of the current page are programmed from the start address of the same page (from the address whose 8 least significant bits (A7-A0) are all zero). Chip Select (CS#) must be driven Low for the entire duration of the sequence.

The instruction sequence is shown in Figure 17. If more than 256 bytes are sent to the device, previously latched data are discarded and the last 256 data bytes are guaranteed to be programmed correctly within the same page. If less than 256 Data bytes are sent to device, they are correctly programmed at the requested addresses without having any effects on the other bytes of the same page.

Chip Select (CS#) must be driven High after the eighth bit of the last data byte has been latched in, otherwise the Page Program (PP) instruction is not executed.

As soon as Chip Select (CS#) is driven High, the self-timed Page Program cycle (whose duration is  $t_{pp}$ ) is initiated. While the Page Program cycle is in progress, the Status Register may be read to check the value of the Write In Progress (WIP) bit. The Write In Progress (WIP) bit is 1 during the self-timed Page Program cycle, and is 0 when it is completed. At some unspecified time before the cycle is completed, the Write Enable Latch (WEL) bit is reset.

A Page Program (PP) instruction applied to a page which is protected by the Block Protect (BP3, BP2, BP1, BP0) bits (see Table 3) is not executed.

The instruction sequence is shown in Figure 17.1 while using the Enable Quad Peripheral Interface mode (EQPI) (38h) command.

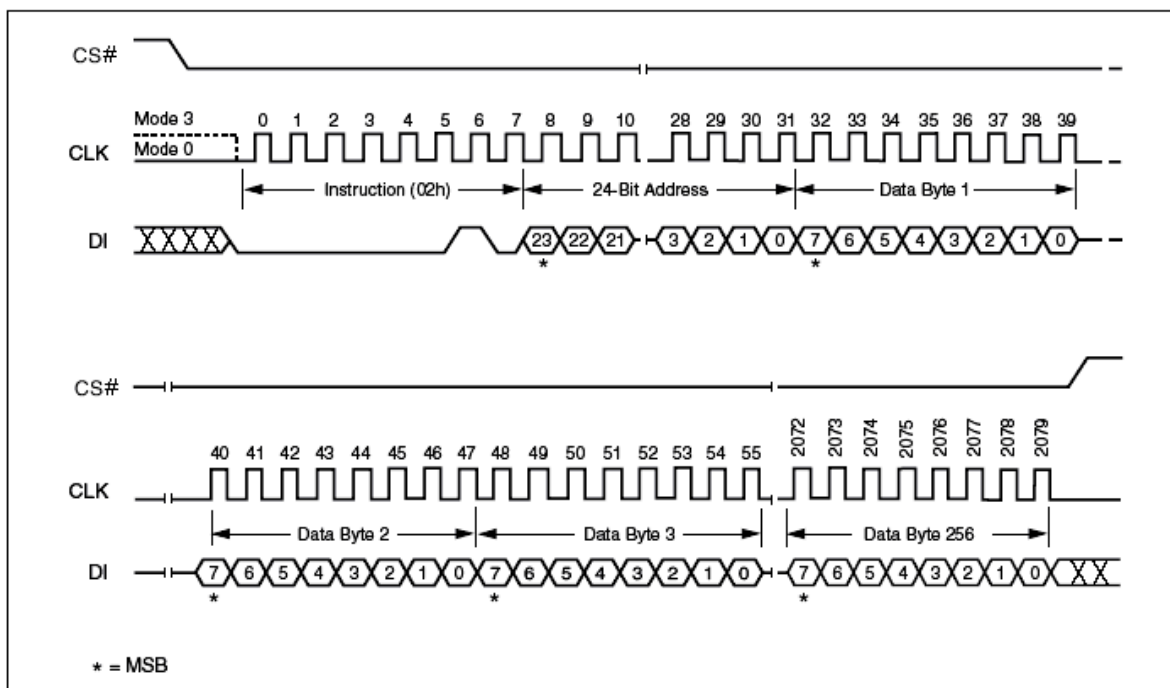

**Figure 17. Page Program Instruction Sequence Diagram**

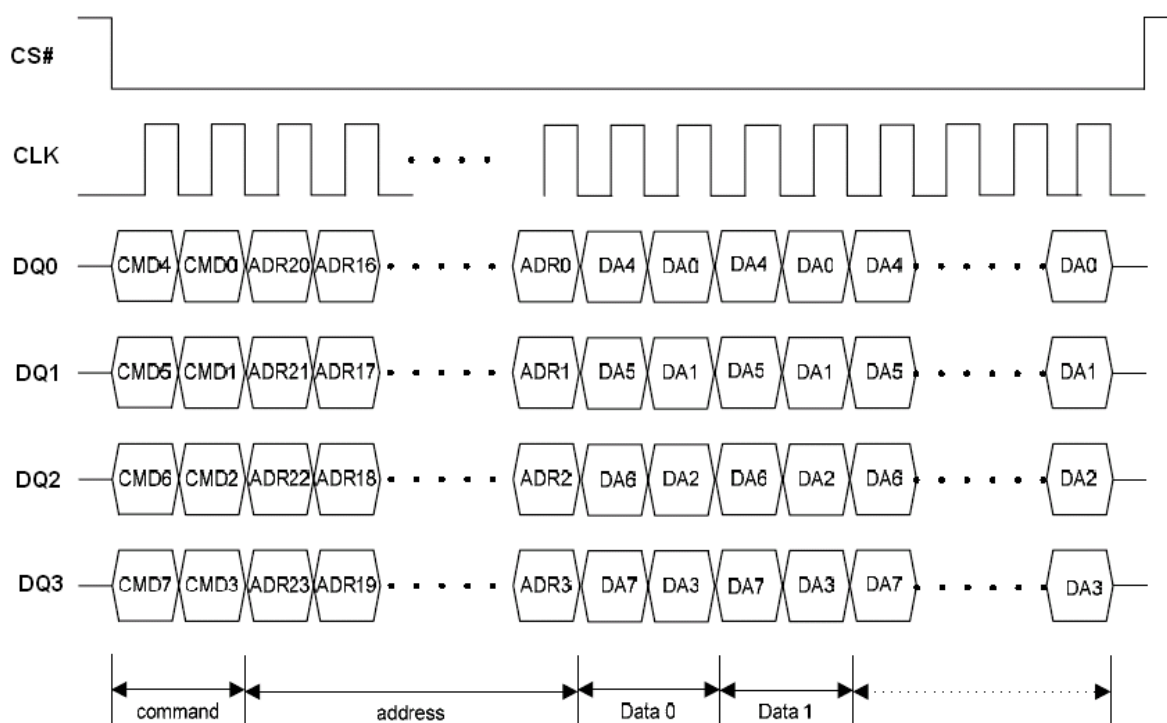

**Figure 17.1 Program Instruction Sequence under EQPI Mode**

### Sector Erase (SE) (20h)

The Sector Erase (SE) instruction sets to 1 (FFh) all bits inside the chosen sector. Before it can be accepted, a Write Enable (WREN) instruction must previously have been executed. After the Write Enable (WREN) instruction has been decoded, the device sets the Write Enable Latch (WEL).

The Sector Erase (SE) instruction is entered by driving Chip Select (CS#) Low, followed by the instruction code, and three address bytes on Serial Data Input (DI). Any address inside the Sector (see Table 2) is a valid address for the Sector Erase (SE) instruction. Chip Select (CS#) must be driven Low for the entire duration of the sequence.

The instruction sequence is shown in Figure 18. Chip Select (CS#) must be driven High after the eighth bit of the last address byte has been latched in, otherwise the Sector Erase (SE) instruction is not executed. As soon as Chip Select (CS#) is driven High, the self-timed Sector Erase cycle (whose duration is  $t_{SE}$ ) is initiated. While the Sector Erase cycle is in progress, the Status Register may be read to check the value of the Write In Progress (WIP) bit. The Write In Progress (WIP) bit is 1 during the self-timed Sector Erase cycle, and is 0 when it is completed. At some unspecified time before the cycle is completed, the Write Enable Latch (WEL) bit is reset.

A Sector Erase (SE) instruction applied to a sector which is protected by the Block Protect (BP3, BP2, BP1, BP0) bits (see Table 3) is not executed.

The instruction sequence is shown in Figure 18.1 while using the Enable Quad Peripheral Interface mode (EQPI) (38h) command.

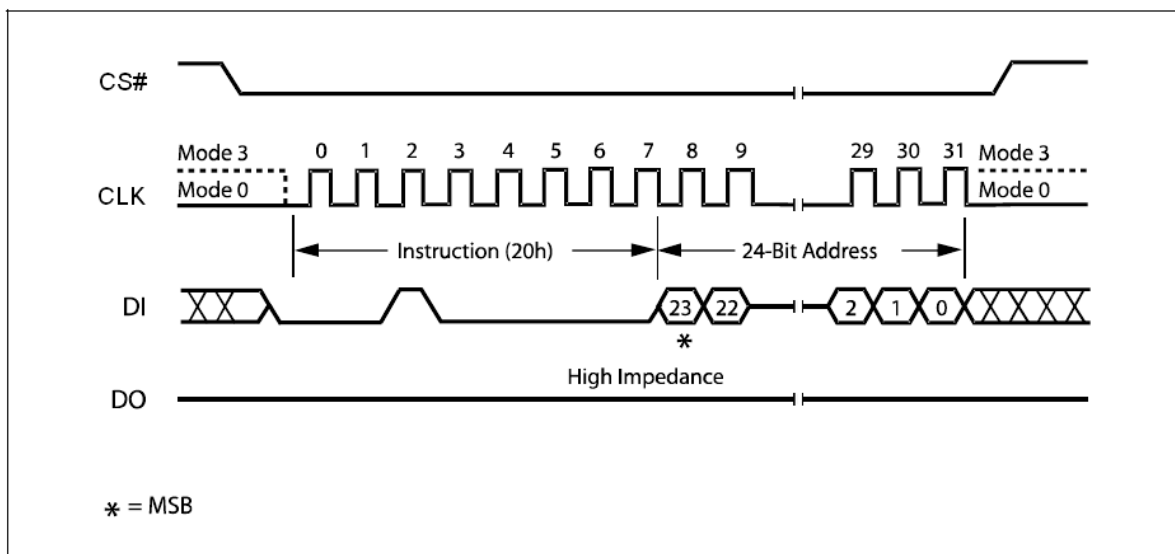

Figure 18. Sector Erase Instruction Sequence Diagram

### Block Erase (BE) (D8h)

The Block Erase (BE) instruction sets to 1 (FFh) all bits inside the chosen block. Before it can be accepted, a Write Enable (WREN) instruction must previously have been executed. After the Write Enable (WREN) instruction has been decoded, the device sets the Write Enable Latch (WEL).

The Block Erase (BE) instruction is entered by driving Chip Select (CS#) Low, followed by the instruction code, and three address bytes on Serial Data Input (DI). Any address inside the Block (see Table 2) is a valid address for the Block Erase (BE) instruction. Chip Select (CS#) must be driven Low for the entire duration of the sequence.

The instruction sequence is shown in Figure 19. Chip Select (CS#) must be driven High after the eighth bit of the last address byte has been latched in, otherwise the Block Erase (BE) instruction is not executed. As soon as Chip Select (CS#) is driven High, the self-timed Block Erase cycle (whose duration is  $t_{BE}$ ) is initiated. While the Block Erase cycle is in progress, the Status Register may be read to check the value of the Write In Progress (WIP) bit. The Write In Progress (WIP) bit is 1 during the self-timed Block Erase cycle, and is 0 when it is completed. At some unspecified time before the cycle is completed, the Write Enable Latch (WEL) bit is reset.

A Block Erase (BE) instruction applied to a block which is protected by the Block Protect (BP3, BP2, BP1, BP0) bits (see Table 3) is not executed.

The instruction sequence is shown in Figure 19.1 while using the Enable Quad Peripheral Interface mode (EQPI) (38h) command.

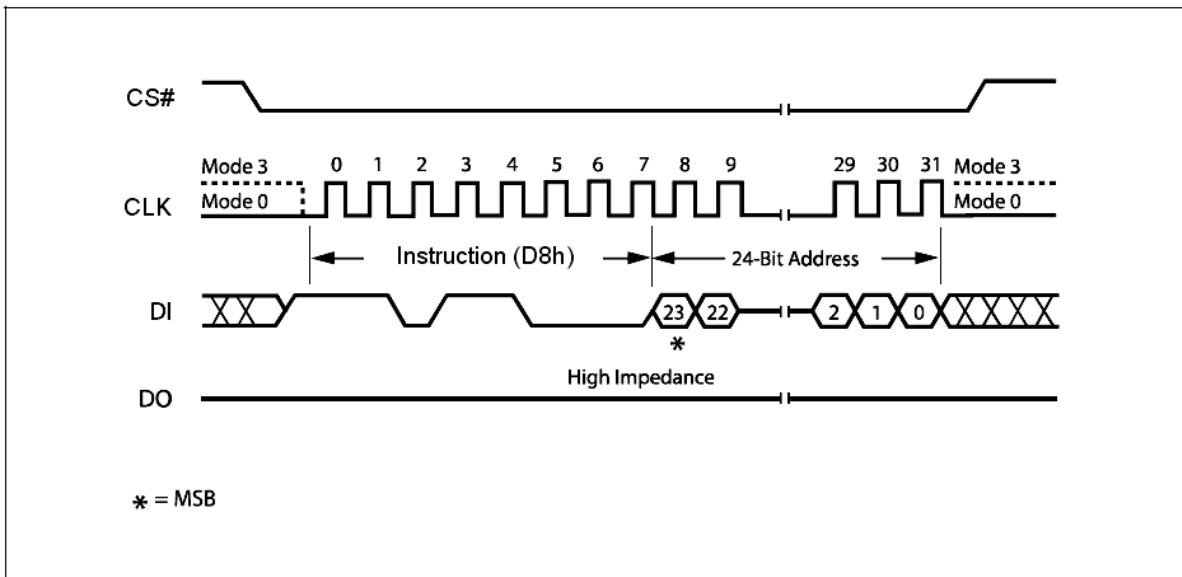
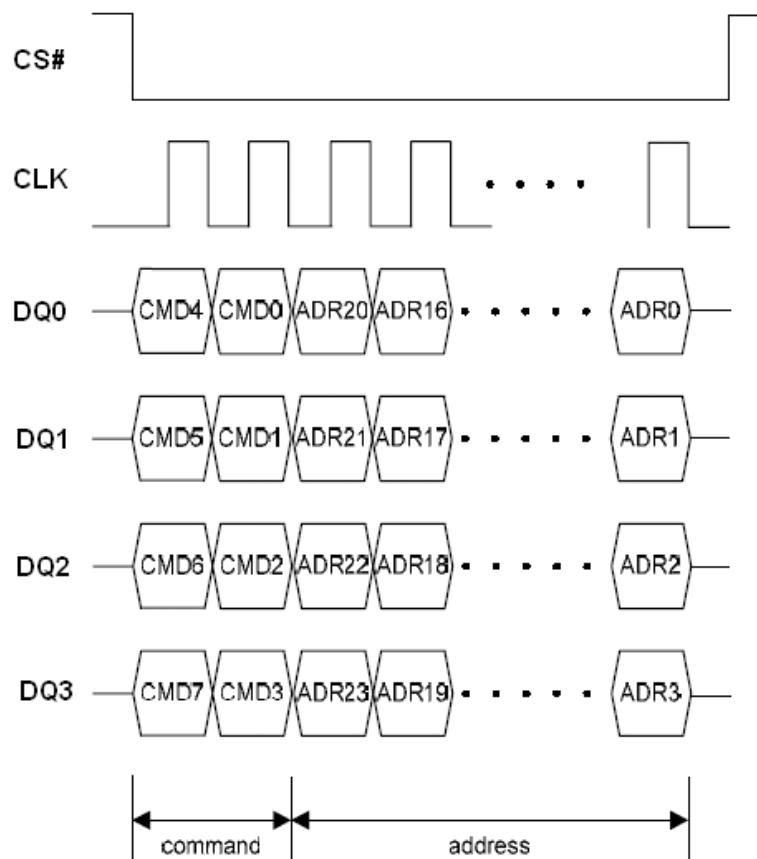
**Figure 19. Block Erase Instruction Sequence Diagram**

**Figure 19.1 Block/Sector Erase Instruction Sequence under EQPI Mode**

**Chip Erase (CE) (C7h/60h)**

The Chip Erase (CE) instruction sets all bits to 1 (FFh). Before it can be accepted, a Write Enable (WREN) instruction must previously have been executed. After the Write Enable (WREN) instruction has been decoded, the device sets the Write Enable Latch (WEL).

The Chip Erase (CE) instruction is entered by driving Chip Select (CS#) Low, followed by the instruction code on Serial Data Input (DI). Chip Select (CS#) must be driven Low for the entire duration of the sequence.

The instruction sequence is shown in Figure 20. Chip Select (CS#) must be driven High after the eighth bit of the instruction code has been latched in, otherwise the Chip Erase instruction is not executed. As soon as Chip Select (CS#) is driven High, the self-timed Chip Erase cycle (whose duration is  $t_{CE}$ ) is initiated. While the Chip Erase cycle is in progress, the Status Register may be read to check the value of the Write In Progress (WIP) bit. The Write In Progress (WIP) bit is 1 during the self-timed Chip Erase cycle, and is 0 when it is completed. At some unspecified time before the cycle is completed, the Write Enable Latch (WEL) bit is reset.

The Chip Erase (CE) instruction is executed only if all Block Protect (BP3, BP2, BP1, BP0) bits are 0. The Chip Erase (CE) instruction is ignored if one, or more blocks are protected.

The instruction sequence is shown in Figure 20.1 while using the Enable Quad Peripheral Interface mode (EQPI) (38h) command.

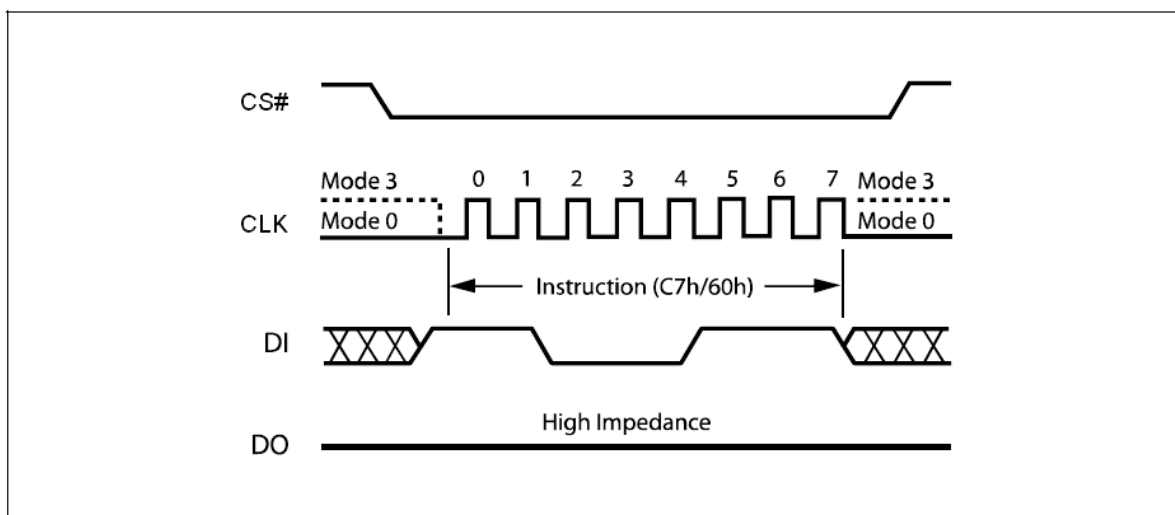

**Figure 20. Chip Erase Instruction Sequence Diagram**

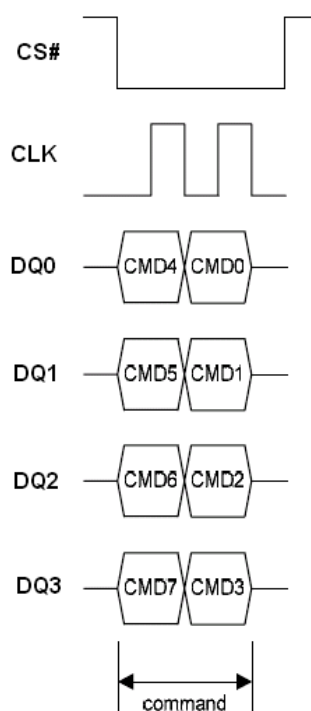

**Figure 20.1 Chip Erase Sequence under EQPI Mode**

### Deep Power-down (DP) (B9h)

Executing the Deep Power-down (DP) instruction is the only way to put the device in the lowest consumption mode (the Deep Power-down mode). It can also be used as an extra software protection mechanism, while the device is not in active use, since in this mode, the device ignores all Write, Program and Erase instructions.

Driving Chip Select (CS#) High deselects the device, and puts the device in the Standby mode (if there is no internal cycle currently in progress). But this mode is not the Deep Power-down mode. The Deep Power-down mode can only be entered by executing the Deep Power-down (DP) instruction, to reduce the standby current (from  $I_{CC1}$  to  $I_{CC2}$ , as specified in Table 12.)

Once the device has entered the Deep Power-down mode, all instructions are ignored except the Release from Deep Power-down and Read Device ID (RDI) instruction. This releases the device from this mode. The Release from Deep Power-down and Read Device ID (RDI) instruction also allows the Device ID of the device to be output on Serial Data Output (DO).

The Deep Power-down mode automatically stops at Power-down, and the device always Powers-up in the Standby mode. The Deep Power-down (DP) instruction is entered by driving Chip Select (CS#) Low, followed by the instruction code on Serial Data Input (DI). Chip Select (CS#) must be driven Low for the entire duration of the sequence.

The instruction sequence is shown in Figure 21. Chip Select (CS#) must be driven High after the eighth bit of the instruction code has been latched in, otherwise the Deep Power-down (DP) instruction is not executed. As soon as Chip Select (CS#) is driven High, it requires a delay of  $t_{DP}$  before the supply current is reduced to  $I_{CC2}$  and the Deep Power-down mode is entered.

Any Deep Power-down (DP) instruction, while an Erase, Program or Write cycle is in progress, is rejected without having any effects on the cycle that is in progress.

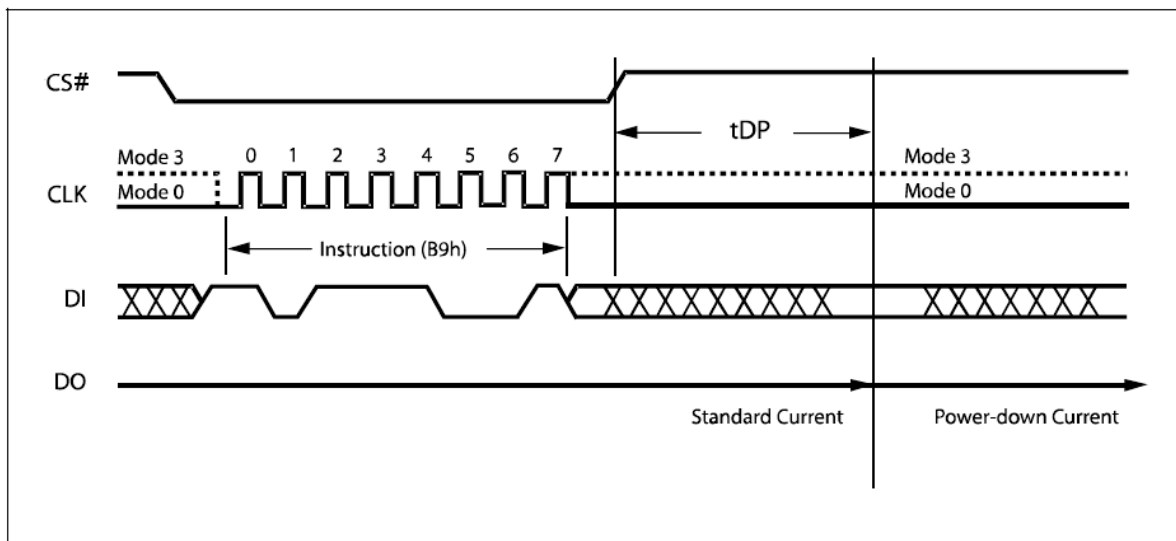

**Figure 21. Deep Power-down Instruction Sequence Diagram**

### Release from Deep Power-down and Read Device ID (RDI)

Once the device has entered the Deep Power-down mode, all instructions are ignored except the Release from Deep Power-down and Read Device ID (RDI) instruction. Executing this instruction takes the device out of the Deep Power-down mode.

Please note that this is not the same as, or even a subset of, the JEDEC 16-bit Electronic Signature that is read by the Read Identifier (RDID) instruction. The old-style Electronic Signature is supported for reasons of backward compatibility, only, and should not be used for new designs. New designs should, instead, make use of the JEDEC 16-bit Electronic Signature, and the Read Identifier (RDID) instruction.

When used only to release the device from the power-down state, the instruction is issued by driving the CS# pin low, shifting the instruction code “ABh” and driving CS# high as shown in Figure 22. After the time duration of  $t_{RES1}$  (See AC Characteristics) the device will resume normal operation and other instructions will be accepted. The CS# pin must remain high during the  $t_{RES1}$  time duration.

When used only to obtain the Device ID while not in the power-down state, the instruction is initiated by driving the CS# pin low and shifting the instruction code “ABh” followed by 3-dummy bytes. The Device ID bits are then shifted out on the falling edge of CLK with most significant bit (MSB) first as shown in Figure 23. The Device ID value for the EN25QH16 are listed in Table 5. The Device ID can be read continuously. The instruction is completed by driving CS# high.

When Chip Select (CS#) is driven High, the device is put in the Stand-by Power mode. If the device was not previously in the Deep Power-down mode, the transition to the Stand-by Power mode is immediate. If the device was previously in the Deep Power-down mode, though, the transition to the Standby Power mode is delayed by  $t_{RES2}$ , and Chip Select (CS#) must remain High for at least  $t_{RES2}$  (max), as specified in Table 14. Once in the Stand-by Power mode, the device waits to be selected, so that it can receive, decode and execute instructions.

Except while an Erase, Program or Write Status Register cycle is in progress, the Release from Deep Power-down and Read Device ID (RDI) instruction always provides access to the 8bit Device ID of the device, and can be applied even if the Deep Power-down mode has not been entered.

Any Release from Deep Power-down and Read Device ID (RDI) instruction while an Erase, Program or Write Status Register cycle is in progress, is not decoded, and has no effect on the cycle that is in progress.

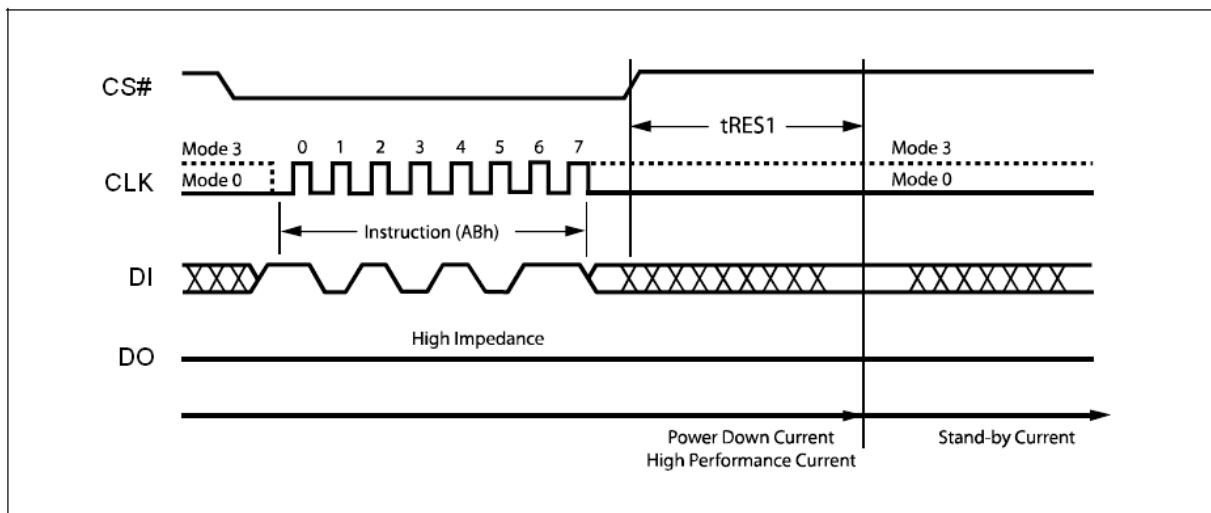
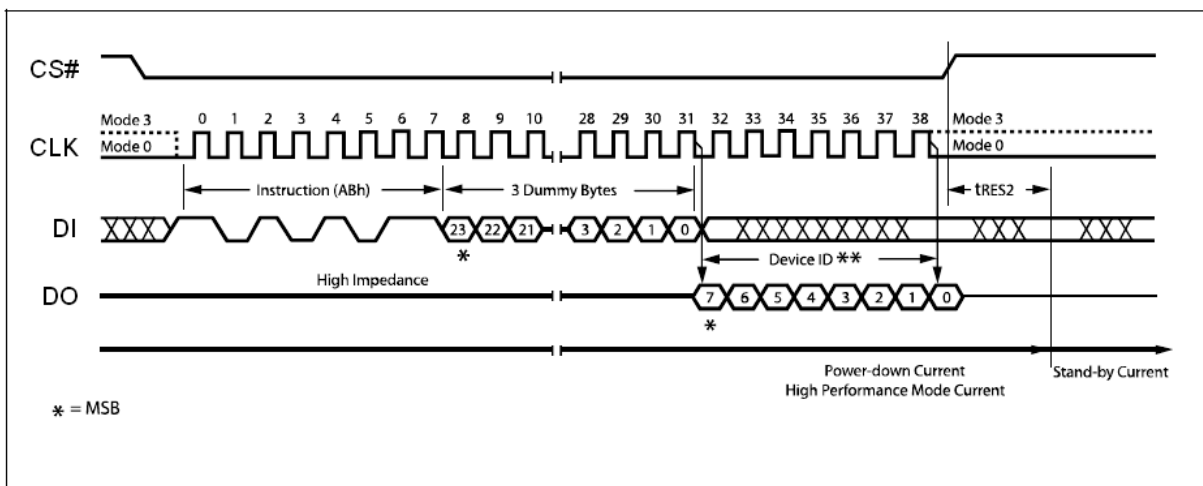
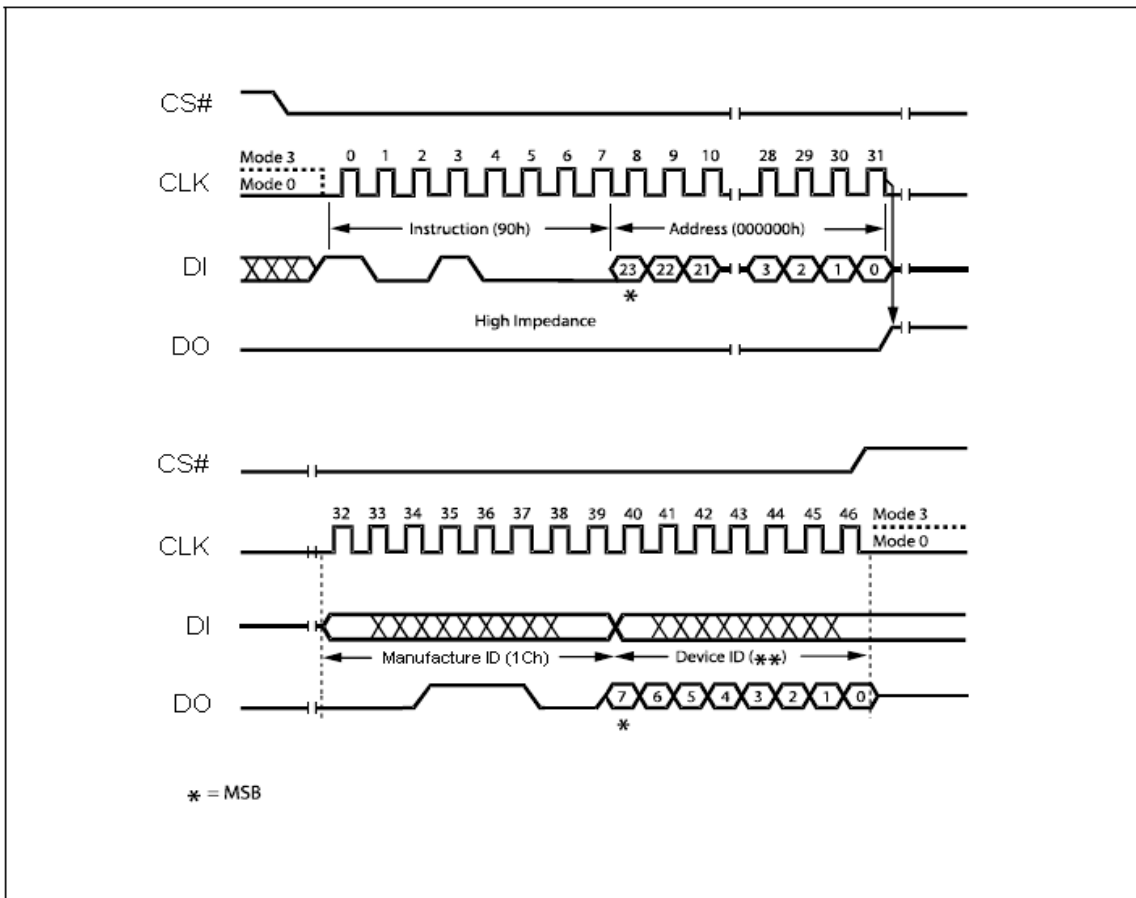
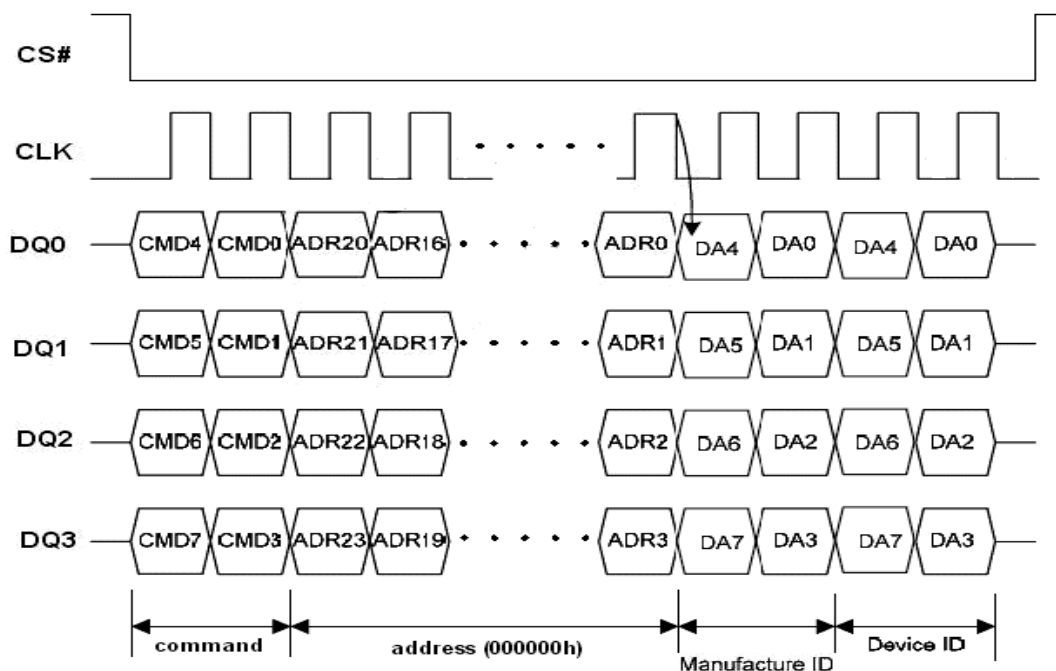

**Figure 22. Release Power-down Instruction Sequence Diagram**

**Figure 23. Release Power-down / Device ID Instruction Sequence Diagram**

### Read Manufacturer / Device ID (90h)

The Read Manufacturer/Device ID instruction is an alternative to the Release from Power-down / Device ID instruction that provides both the JEDEC assigned manufacturer ID and the specific device ID.

The Read Manufacturer/Device ID instruction is very similar to the Release from Power-down / Device ID instruction. The instruction is initiated by driving the CS# pin low and shifting the instruction code "90h" followed by a 24-bit address of 000000h. After which, the Manufacturer ID for Eon (1Ch) and the Device ID are shifted out on the falling edge of CLK with most significant bit (MSB) first as shown in Figure 24. The Device ID values for the EN25QH16 are listed in Table 5. If the 24-bit address is initially set to 000001h the Device ID will be read first

The instruction sequence is shown in Figure 24.1 while using the Enable Quad Peripheral Interface mode (EQPI) (38h) command.

**Figure 24. Read Manufacturer / Device ID Diagram**

**Figure 24.1. Read Manufacturer / Device ID Diagram under EQPI Mode**

**Read Identification (RDID) (9Fh)**

The Read Identification (RDID) instruction allows the 8-bit manufacturer identification to be read, followed by two bytes of device identification. The device identification indicates the memory type in the first byte, and the memory capacity of the device in the second byte.

Any Read Identification (RDID) instruction while an Erase or Program cycle is in progress, is not decoded, and has no effect on the cycle that is in progress. The Read Identification (RDID) instruction should not be issued while the device is in Deep Power down mode.

The device is first selected by driving Chip Select Low. Then, the 8-bit instruction code for the instruction is shifted in. This is followed by the 24-bit device identification, stored in the memory, being shifted out on Serial Data Output, each bit being shifted out during the falling edge of Serial Clock. The instruction sequence is shown in Figure 25. The Read Identification (RDID) instruction is terminated by driving Chip Select High at any time during data output.

When Chip Select is driven High, the device is put in the Standby Power mode. Once in the Standby Power mode, the device waits to be selected, so that it can receive, decode and execute instructions.

The instruction sequence is shown in Figure 25.1 while using the Enable Quad Peripheral Interface mode (EQPI) (38h) command.

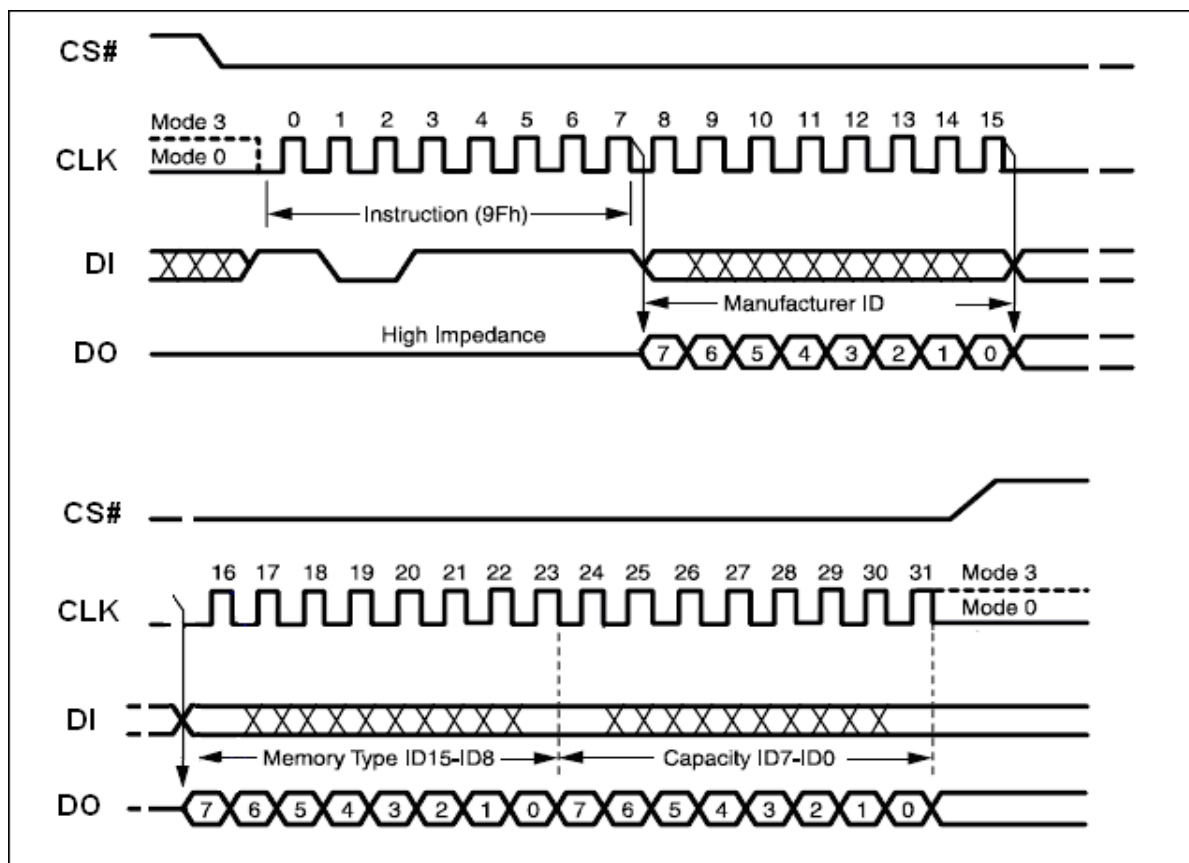

**Figure 25. Read Identification (RDID)**

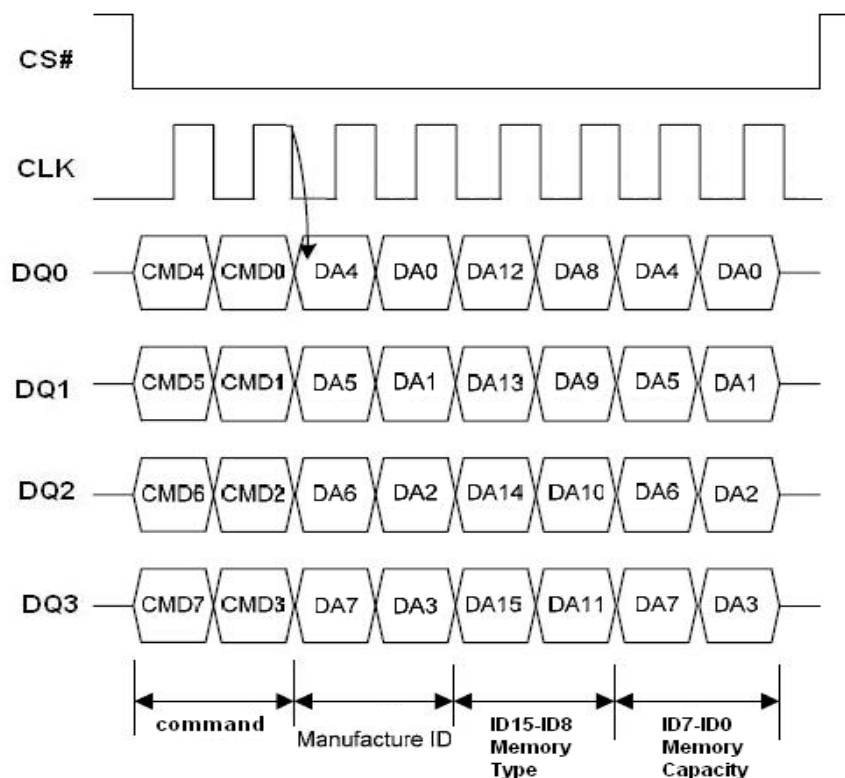

**Figure 25.1. Read Identification (RDID) under EQPI Mode**

### Enter OTP Mode (3Ah)

This Flash has an extra 512 bytes OTP sector, user must issue ENTER OTP MODE command to read, program or erase OTP sector. After entering OTP mode, the OTP sector is mapping to sector 511, **SRP bit** becomes OTP\_LOCK bit and can be read with RDSR command. Program / Erase command will be disabled when OTP\_LOCK bit is '1'

WRSR command will ignore the input data and program OTP\_LOCK bit to 1. User must clear the protect bits before enter OTP mode.

OTP sector can only be program and erase before OTP\_LOCK bit is set to '1' and BP [3:0] = '0000'. In OTP mode, user can read other sectors, but program/erase other sectors only allowed when OTP\_LOCK bit equal to '0'.

User can use WRDI (04h) command to exit OTP mode.

While in OTP mode, user can use Sector Erase (20h) command only to erase OTP data.

The instruction sequence is shown in Figure 26.1 while using the Enable Quad Peripheral Interface mode (EQPI) (38h) command.

**Table 7. OTP Sector Address**

Sector	Sector Size	Address Range
511	512 byte	1FF000h – 1FF1FFh

Note: The OTP sector is mapping to sector 511.

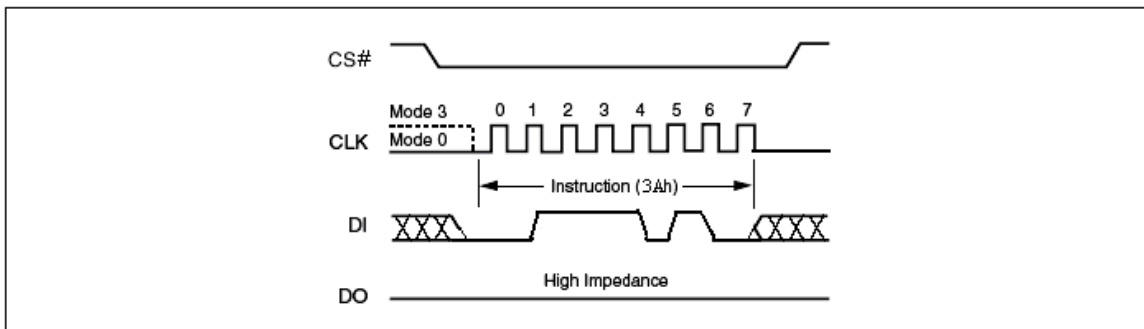
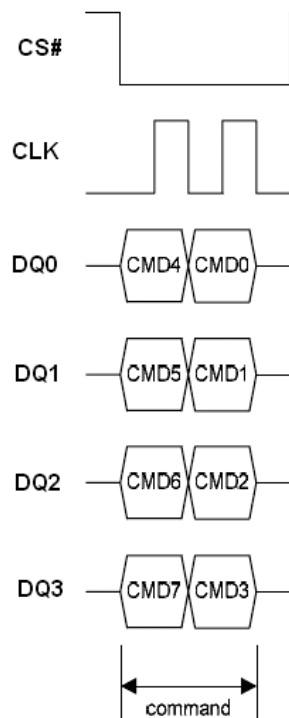
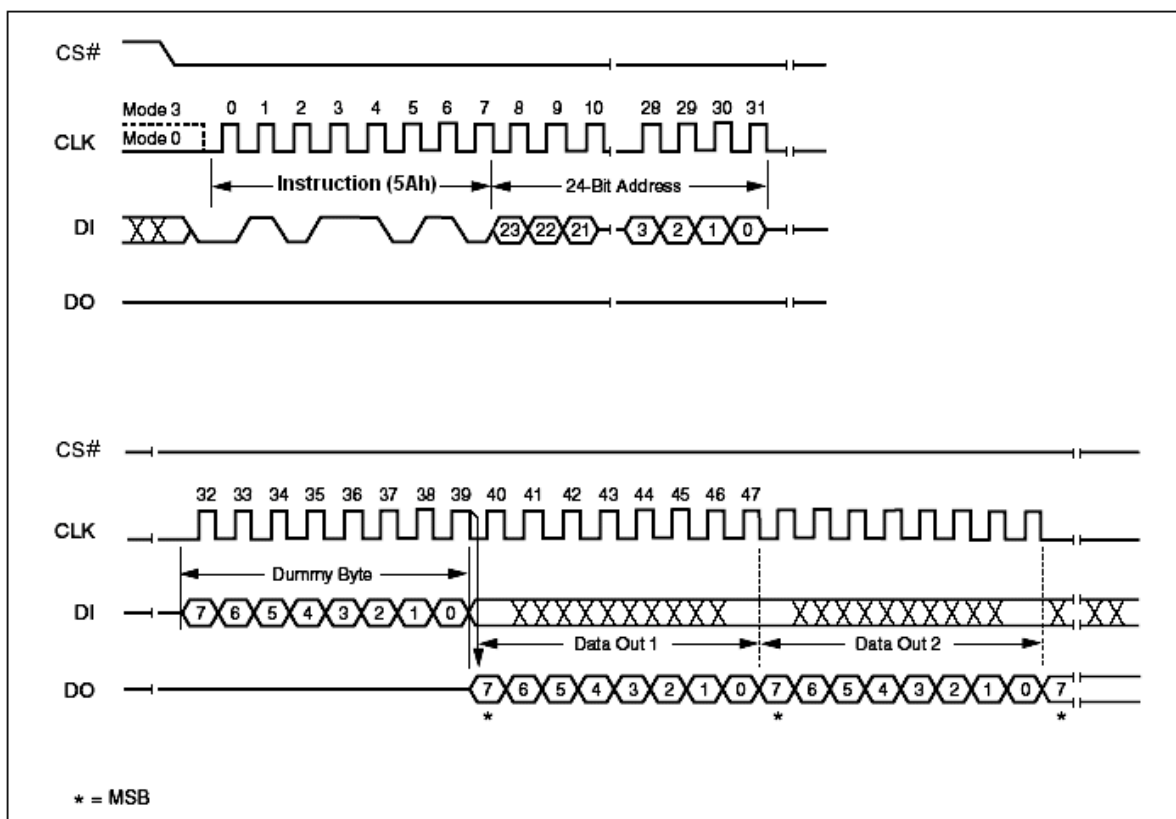

**Figure 26. Enter OTP Mode Sequence**

**Figure 26.1 Enter OTP Mode Sequence under EQPI Mode**

**Read SFDP Mode and Unique ID Number (5Ah)**
**Read SFDP Mode**

EN25QH16 features Serial Flash Discoverable Parameters (SFDP) mode. Host system can retrieve the operating characteristics, structure and vendor specified information such as identifying information, memory size, operating voltage and timing information of this device by SFDP mode.

The device is first selected by driving Chip Select (CS#) Low. The instruction code for the Read SFDP Mode is followed by a 3-byte address (A23-A0) and a dummy byte, each bit being latched-in during the rising edge of Serial Clock (CLK). Then the memory contents, at that address, is shifted out on Serial Data Output (DO), each bit being shifted out, at a maximum frequency FR, during the falling edge of Serial Clock (CLK).

The instruction sequence is shown in Figure 27. The first byte addressed can be at any location. The address is automatically incremented to the next higher address after each byte of data is shifted out. The whole memory can, therefore, be read with a single Serial Flash Discoverable Parameters (SFDP) instruction. When the highest address is reached, the address counter rolls over to 0x00h, allowing the read sequence to be continued indefinitely. The Serial Flash Discoverable Parameters (SFDP) instruction is terminated by driving Chip Select (CS#) High. Chip Select (CS#) can be driven High at any time during data output. Any Read Data Bytes at Serial Flash Discoverable Parameters (SFDP) instruction, while an Erase, Program or Write cycle is in progress, is rejected without having any effects on the cycle that is in progress.



**Figure 27. Read SFDP Mode and Unique ID Number Instruction Sequence Diagram**



Table 8. Serial Flash Discoverable Parameters (SFDP) Signature and Parameter Identification Data Value (Advanced Information)

Description	Address (h) (Byte Mode)	Address (Bit)	Data	Comment
SFDP Signature	00h	07 : 00	53h	Signature [31:0]: Hex: 50444653
	01h	15 : 08	46h	
	02h	23 : 16	44h	
	03h	31 : 24	50h	
SFDP Minor Revision Number	04h	07 : 00	00h	Star from 0x00
SFDP Major Revision Number	05h	15 : 08	01h	Star from 0x01
Number of Parameter Headers (NPH)	06h	23 : 16	00h	1 parameter header
Unused	07h	31 : 24	FFh	Reserved
ID Number	08h	07 : 00	00h	JEDEC ID
Parameter Table Minor Revision Number	09h	15 : 08	00h	Star from 0x00
Parameter Table Major Revision Number	0Ah	23 : 16	01h	Star from 0x01
Parameter Table Length (in DW)	0Bh	31 : 24	09h	9 DWORDs
Parameter Table Pointer (PTP)	0Ch	07 : 00	30h	000030h
	0Dh	15 : 08	00h	
	0Eh	23 : 16	00h	
Unused	0Fh	31 : 24	FFh	Reserved



Table 9. Parameter ID (0) (Advanced Information) 1/9

Description	Address (h) (Byte Mode)	Address (Bit)	Data	Comment	
<b>Block / Sector Erase sizes</b> Identifies the erase granularity for all Flash Components	30h	00	01b	00 = reserved 01 = 4KB erase 10 = reserved 11 = 64KB erase	
		01			
<b>Write Granularity</b>		02	1b	0 = No, 1 = Yes	
<b>Write Enable Instruction Required for Writing to Volatile Status Register</b>		03	00b	00 = N/A 01 = use 50h opcode 11 = use 06h opcode	
<b>Write Enable Opcode Select for Writing to Volatile Status Register</b>		04			
<b>Unused</b>		05	111b	Reserved	
		06			
		07			
<b>4 Kilo-Byte Erase Opcode</b>		31h	08	20h	4 KB Erase Support (FFh = not supported)
			09		
	10				
	11				
	12				
	13				
	14				
<b>Supports (1-1-2) Fast Read</b> Device supports single input opcode & address and quad output data Fast Read	32h	16	1b	0 = not supported 1 = supported	
<b>Address Byte</b> Number of bytes used in addressing for flash array write and erase.		17	00b	00 = 3-Byte 01 = 3- or 4-Byte (e.g. defaults to 3-Byte mode; enters 4-Byte mode on command) 10 = 4-Byte 11 = reserved	
		18			
<b>Supports Double Transfer Rate (DTR) Clocking</b> Indicates the device supports some type of double transfer rate clocking.		19	0b	0 = not supported 1 = supported	
<b>Supports (1-2-2) Fast Read</b> Device supports single input opcode, dual input address, and quad output data Fast Read		20	1b	0 = not supported 1 = supported	
<b>Supports (1-4-4) Fast Read</b> Device supports single input opcode, quad input address, and quad output data Fast Read		21	1b	0 = not supported 1 = supported	
<b>Supports (1-1-4) Fast Read</b> Device supports single input opcode & address and quad output data Fast Read		22	0b	0 = not supported 1 = supported	
<b>Unused</b>		23	1b	Reserved	
<b>Unused</b>		33h	24	FFh	Reserved
			25		
	26				
	27				
	28				
	29				
	30				
31					



Table 9. Parameter ID (0) (Advanced Information) 2/9

Description	Address (h) (Byte Mode)	Address (Bit)	Data	Comment
Flash Memory Density	37h : 34h	31 : 00	00FFFFFFh	16 Mbits

Table 9. Parameter ID (0) (Advanced Information) 3/9

Description	Address (h) (Byte Mode)	Address (Bit)	Data	Comment
<b>(1-4-4) Fast Read Number of Wait states (dummy clocks) needed before valid output</b>	38h	00	00100b	4 dummy clocks
		01		
		02		
		03		
		04		
<b>Quad Input Address Quad Output (1-4-4) Fast Read Number of Mode Bits</b>	38h	05	010b	8 mode bits
		06		
		07		
<b>(1-4-4) Fast Read Opcode</b> Opcode for single input opcode, quad input address, and quad output data Fast Read.	39h	08	EBh	
		09		
		10		
		11		
		12		
		13		
		14		
		15		
<b>(1-1-4) Fast Read Number of Wait states (dummy clocks) needed before valid output</b>	3Ah	16	00000b	Not Supported
		17		
		18		
		19		
<b>(1-1-4) Fast Read Number of Mode Bits</b>	3Ah	20	000b	Not Supported
		21		
		22		
<b>(1-1-4) Fast Read Opcode</b> Opcode for single input opcode & address and quad output data Fast Read.	3Bh	23	FFh	Not Supported
		31 : 24		



Table 9. Parameter ID (0) (Advanced Information) 4/9

Description	Address (h) (Byte Mode)	Address (Bit)	Data	Comment
<b>(1-1-2) Fast Read Number of Wait states (dummy clocks) needed before valid output</b>	3Ch	00	01000b	8 dummy clocks
		01		
		02		
		03		
		04		
<b>(1-1-2) Fast Read Number of Mode Bits</b>	3Ch	05	000b	Not Supported
		06		
		07		
<b>(1-1-2) Fast Read Opcode</b> Opcode for single input opcode & address and dual output data Fast Read.	3Dh	15 : 08	3Bh	
<b>(1-2-2) Fast Read Number of Wait states (dummy clocks) needed before valid output</b>	3Eh	16	00100b	4 dummy clocks
		17		
		18		
		19		
		20		
<b>(1-2-2) Fast Read Number of Mode Bits</b>	3Eh	21	000b	Not Supported
		22		
		23		
<b>(1-2-2) Fast Read Opcode</b> Opcode for single input opcode, dual input address, and dual output data Fast Read.	3Fh	31 : 24	BBh	

Table 9. Parameter ID (0) (Advanced Information) 5/9

Description	Address (h) (Byte Mode)	Address (Bit)	Data	Comment
<b>Supports (2-2-2) Fast Read</b> Device supports dual input opcode & address and dual output data Fast Read.	40h	00	0b	0 = not supported 1 = supported
Reserved. These bits default to all 1's		01	111b	Reserved
		02		
		03		
<b>Supports (4-4-4) Fast Read</b> Device supports Quad input opcode & address and quad output data Fast Read.		04	1b	0 = not supported 1 = supported (EQPI Mode)
Reserved. These bits default to all 1's		05	111b	Reserved
		06		
	07			
Reserved. These bits default to all 1's	43h : 41h	31 : 08	FFh	Reserved



Table 9. Parameter ID (0) (Advanced Information) 6/9

Description	Address (h) (Byte Mode)	Address (Bit)	Data	Comment
Reserved. These bits default to all 1's	45h : 44h	15 : 00	FFh	Reserved
<b>(2-2-2) Fast Read Number of Wait states (dummy clocks) needed before valid output</b>	46h	16	00000b	Not Supported
		17		
		18		
		19		
<b>(2-2-2) Fast Read Number of Mode Bits</b>	46h	20	000b	Not Supported
		21		
		22		
<b>(2-2-2) Fast Read Opcode</b> Opcode for dual input opcode & address and dual output data Fast Read.	47h	23	FFh	Not Supported
		31 : 24		

Table 9. Parameter ID (0) (Advanced Information) 7/9

Description	Address (h) (Byte Mode)	Address (Bit)	Data	Comment
Reserved. These bits default to all 1's	49h : 48h	15 : 00	FFh	Reserved
<b>(4-4-4) Fast Read Number of Wait states (dummy clocks) needed before valid output</b>	4Ah	16	00100b	4 dummy clocks
		17		
		18		
		19		
<b>(4-4-4) Fast Read Number of Mode Bits</b>	4Ah	20	010b	8 mode bits
		21		
		22		
<b>(4-4-4) Fast Read Opcode</b> Opcode for quad input opcode/address, quad output data Fast Read.	4Bh	23	EBh	Must Enter EQPI Mode Firstly
		31 : 24		

Table 9. Parameter ID (0) (Advanced Information) 8/9

Description	Address (h) (Byte Mode)	Address (Bit)	Data	Comment
<b>Sector Type 1 Size</b>	4Ch	07 : 00	0Ch	4 KB
<b>Sector Type 1 Opcode</b>	4Dh	15 : 08	20h	
<b>Sector Type 2 Size</b>	4Eh	23 : 16	00h	Not Supported
<b>Sector Type 2 Opcode</b>	4Fh	31 : 24	FFh	Not Supported

Table 9. Parameter ID (0) (Advanced Information) 9/9

Description	Address (h) (Byte Mode)	Address (Bit)	Data	Comment
<b>Sector Type 3 Size</b>	50h	07 : 00	10h	64 KB
<b>Sector Type 3 Opcode</b>	51h	15 : 08	D8h	
<b>Sector Type 4 Size</b>	52h	23 : 16	00h	Not Supported
<b>Sector Type 4 Opcode</b>	53h	31 : 24	FFh	Not Supported

### Read Unique ID Number

The Read Unique ID Number instruction accesses a factory-set read-only 96-bit number that is unique to each EN25QH16 device. The ID number can be used in conjunction with user software methods to help prevent copying or cloning of a system. The Read Unique ID instruction is initiated by driving the CS# pin low and shifting the instruction code "5Ah" followed by a three bytes of addresses, 0x80h, and one byte of dummy clocks. After which, the 96-bit ID is shifted out on the falling edge of CLK as shown in figure 27.

**Table 10. Unique ID Number**

Description	Address (h) (Byte Mode)	Address (Bit)	Data	Comment
Unique ID Number	80h : 8Bh	95 : 00	By die	

### Power-up Timing

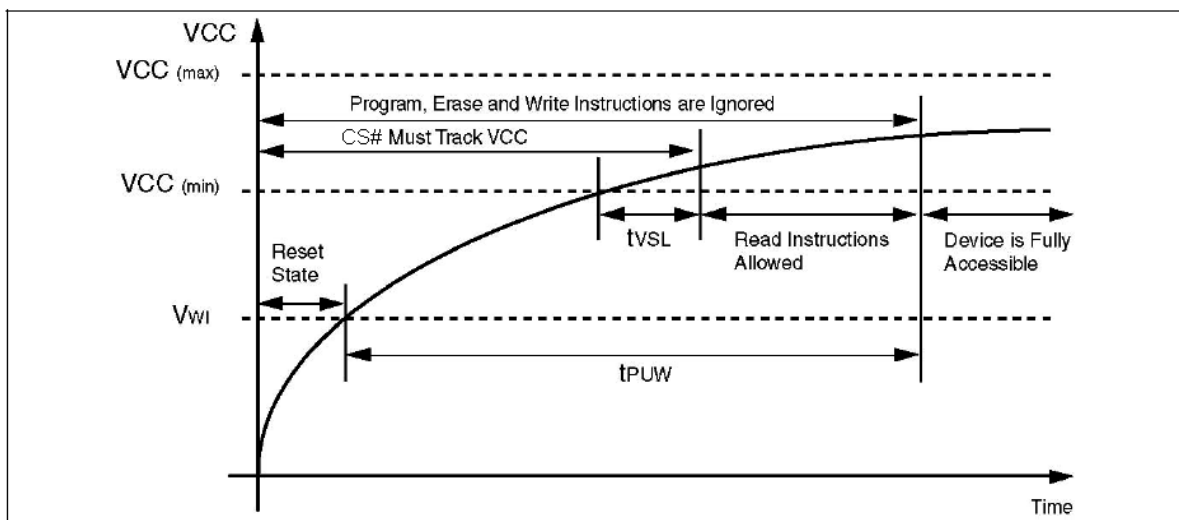

**Figure 28. Power-up Timing**

**Table 11. Power-Up Timing and Write Inhibit Threshold**

Symbol	Parameter	Min.	Max.	Unit
$t_{VSL}^{(1)}$	VCC(min) to CS# low	10		$\mu s$
$t_{PUW}^{(1)}$	Time delay to Write instruction	1	10	ms
$V_{WI}^{(1)}$	Write Inhibit Voltage	1	2.5	V

**Note:**

1. The parameters are characterized only.
2. VCC (max.) is 3.6V and VCC (min.) is 2.7V

### INITIAL DELIVERY STATE

The device is delivered with the memory array erased: all bits are set to 1 (each byte contains FFh). The Status Register contains 00h (all Status Register bits are 0).

**Table 12. DC Characteristics**

 (T<sub>a</sub> = - 40°C to 85°C; V<sub>CC</sub> = 2.7-3.6V)

Symbol	Parameter	Test Conditions	Min.	Max.	Unit
I <sub>LI</sub>	Input Leakage Current		-	± 2	μA
I <sub>LO</sub>	Output Leakage Current		-	± 2	μA
I <sub>CC1</sub>	Standby Current	CS# = V <sub>CC</sub> , V <sub>IN</sub> = V <sub>SS</sub> or V <sub>CC</sub>	-	20	μA
I <sub>CC2</sub>	Deep Power-down Current	CS# = V <sub>CC</sub> , V <sub>IN</sub> = V <sub>SS</sub> or V <sub>CC</sub>	-	20	μA
I <sub>CC3</sub>	Operating Current (READ)	CLK = 0.1 V <sub>CC</sub> / 0.9 V <sub>CC</sub> at 104MHz, DQ = open	-	25	mA
		CLK = 0.1 V <sub>CC</sub> / 0.9 V <sub>CC</sub> at 80MHz, DQ = open	-	20	mA
I <sub>CC4</sub>	Operating Current (PP)	CS# = V <sub>CC</sub>	-	28	mA
I <sub>CC5</sub>	Operating Current (WRSR)	CS# = V <sub>CC</sub>	-	18	mA
I <sub>CC6</sub>	Operating Current (SE)	CS# = V <sub>CC</sub>	-	25	mA
I <sub>CC7</sub>	Operating Current (BE)	CS# = V <sub>CC</sub>	-	25	mA
V <sub>IL</sub>	Input Low Voltage		- 0.5	0.2 V <sub>CC</sub>	V
V <sub>IH</sub>	Input High Voltage		0.7V <sub>CC</sub>	V <sub>CC</sub> +0.4	V
V <sub>OL</sub>	Output Low Voltage	I <sub>OL</sub> = 1.6 mA	-	0.4	V
V <sub>OH</sub>	Output High Voltage	I <sub>OH</sub> = -100 μA	V <sub>CC</sub> -0.2	-	V

**Table 13. AC Measurement Conditions**

Symbol	Parameter	Min.	Max.	Unit
C <sub>L</sub>	Load Capacitance	20		pF
	Input Rise and Fall Times	5		ns
	Input Pulse Voltages	0.2V <sub>CC</sub> to 0.8V <sub>CC</sub>		V
	Input Timing Reference Voltages	0.3V <sub>CC</sub> to 0.7V <sub>CC</sub>		V
	Output Timing Reference Voltages	V <sub>CC</sub> / 2		V

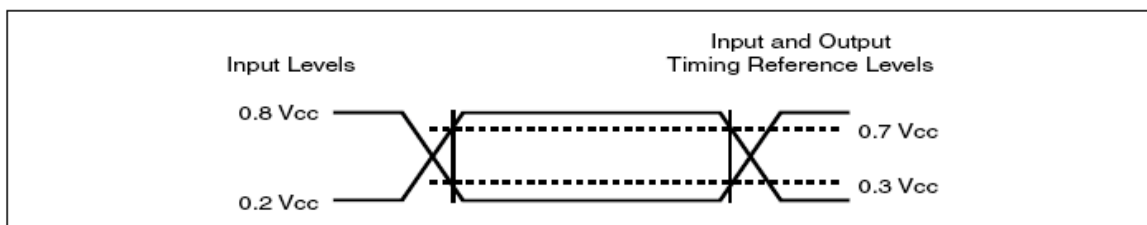
**Figure 29. AC Measurement I/O Waveform**



**Table 14. AC Characteristics**

( $T_a = -40^{\circ}\text{C}$  to  $85^{\circ}\text{C}$ ;  $V_{CC} = 2.7\text{-}3.6\text{V}$ )

Symbol	Alt	Parameter	Min	Typ	Max	Unit	
$F_R$	$f_C$	Serial Clock Frequency for: FAST_READ, PP, SE, BE, DP, RES, WREN, WRDI, WRSR	D.C.	-	104	MHz	
		Serial Clock Frequency for: RDSR, RDID, Dual Output Fast Read and Quad I/O Fast Read	D.C.	-	80	MHz	
$f_R$		Serial Clock Frequency for READ	D.C.	-	50	MHz	
$t_{CH}^1$		Serial Clock High Time	4	-	-	ns	
$t_{CL}^1$		Serial Clock Low Time	4	-	-	ns	
$t_{CLCH}^2$		Serial Clock Rise Time (Slew Rate)	0.1	-	-	V / ns	
$t_{CHCL}^2$		Serial Clock Fall Time (Slew Rate)	0.1	-	-	V / ns	
$t_{SLCH}$	$t_{CSS}$	CS# Active Setup Time (Relative to CLK)	5	-	-	ns	
$t_{CHSH}$		CS# Active Hold Time (Relative to CLK)	5	-	-	ns	
$t_{SHCH}$		CS# Not Active Setup Time (Relative to CLK)	5	-	-	ns	
$t_{CHSL}$		CS# Not Active Hold Time (Relative to CLK)	5	-	-	ns	
$t_{SHSL}$	$t_{CSH}$	CS# High Time for read	15	-	-	ns	
		CS# High Time for program/erase	50	-	-	ns	
$t_{SHQZ}^2$	$t_{DIS}$	Output Disable Time	-	-	6	ns	
$t_{CLQX}$	$t_{HO}$	Output Hold Time	0	-	-	ns	
$t_{DVCH}$	$t_{DSU}$	Data In Setup Time	2	-	-	ns	
$t_{CHDX}$	$t_{DH}$	Data In Hold Time	5	-	-	ns	
$t_{HLCH}$		HOLD# Low Setup Time ( relative to CLK )	5			ns	
$t_{HHCH}$		HOLD# High Setup Time ( relative to CLK )	5			ns	
$t_{CHHH}$		HOLD# Low Hold Time ( relative to CLK )	5			ns	
$t_{CHHL}$		HOLD# High Hold Time ( relative to CLK )	5			ns	
$t_{HLQZ}^2$	$t_{HZ}$	HOLD# Low to High-Z Output			6	ns	
$t_{HHQX}^2$	$t_{LZ}$	HOLD# High to Low-Z Output			6	ns	
$t_{CLQV}$	$t_V$	Output Valid from CLK	-	-	8	ns	
$t_{WHSL}^3$		Write Protect Setup Time before CS# Low	20	-	-	ns	
$t_{SHWL}^3$		Write Protect Hold Time after CS# High	100	-	-	ns	
$t_{DP}^2$		CS# High to Deep Power-down Mode	-	-	3	$\mu\text{s}$	
$t_{RES1}^2$		CS# High to Standby Mode without Electronic Signature read	-	-	3	$\mu\text{s}$	
$t_{RES2}^2$		CS# High to Standby Mode with Electronic Signature read	-	-	1.8	$\mu\text{s}$	
$t_W$		Write Status Register Cycle Time	-	15	50	ms	
$t_{PP}$		Page Programming Time	-	1.3	5	ms	
$t_{SE}$		Sector Erase Time	-	0.06	0.3	s	
$t_{BE}$		Block Erase Time	-	0.4	2	s	
$t_{CE}$		Chip Erase Time	-	12	30	s	
$t_{SR}$		Software Reset	WIP = write operation	-	-	28	$\mu\text{s}$
		Latency	WIP = not in write operation	-	-	0	$\mu\text{s}$

**Note:** 1.  $t_{CH} + t_{CL}$  must be greater than or equal to  $1/f_C$

2. Value guaranteed by characterization, not 100% tested in production.

3. Only applicable as a constraint for a Write status Register instruction when Status Register Protect Bit is set at 1.

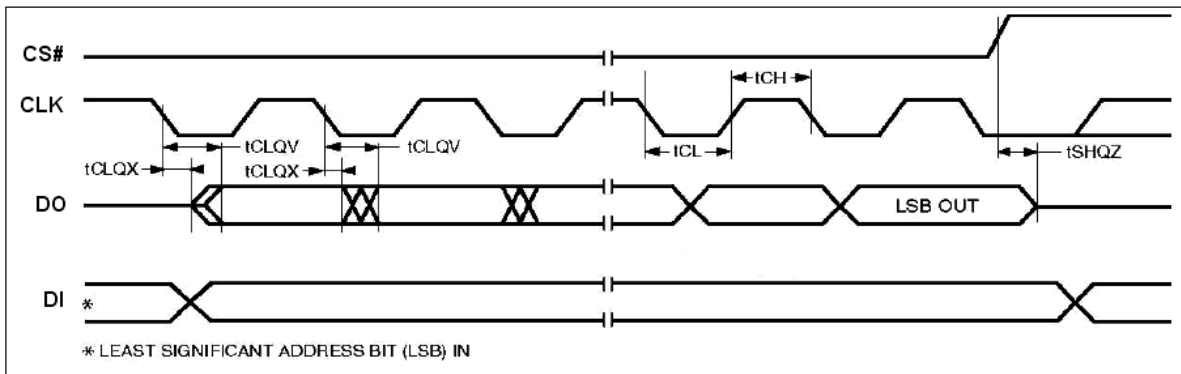
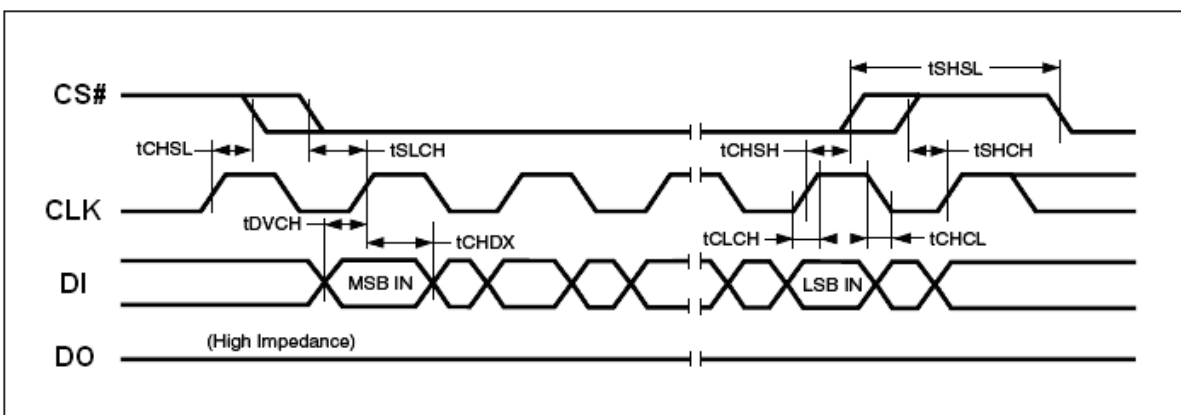
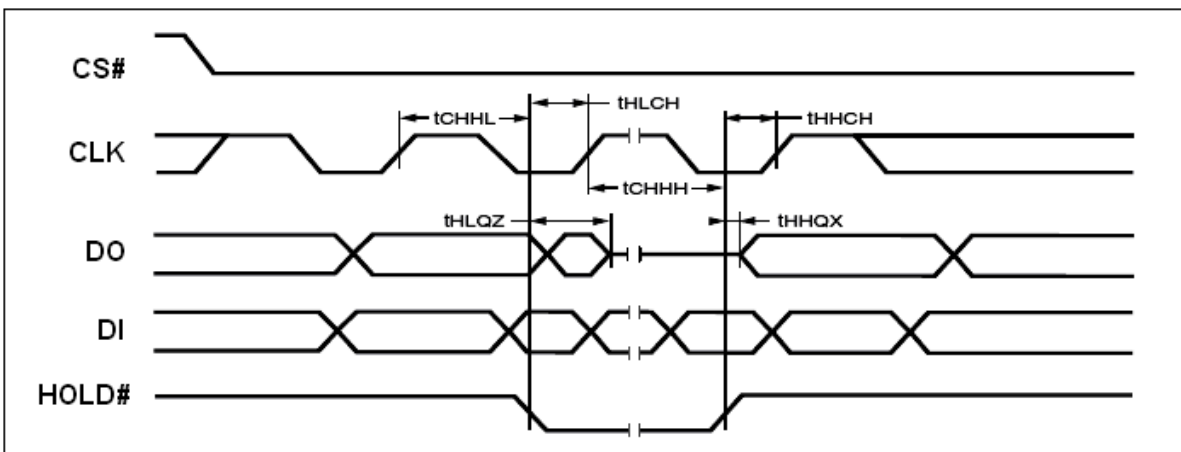
**Figure 30. Serial Output Timing**

**Figure 31. Input Timing**

**Figure 32. Hold Timing**

## ABSOLUTE MAXIMUM RATINGS

Stresses above the values so mentioned above may cause permanent damage to the device. These values are for a stress rating only and do not imply that the device should be operated at conditions up to or above these values. Exposure of the device to the maximum rating values for extended periods of time may adversely affect the device reliability.

Parameter	Value	Unit
Storage Temperature	-65 to +150	C
Plastic Packages	-65 to +125	C
Output Short Circuit Current <sup>1</sup>	200	mA
Input and Output Voltage (with respect to ground) <sup>2</sup>	-0.5 to +4.0	V
V <sub>cc</sub>	-0.5 to +4.0	V

Notes:

- No more than one output shorted at a time. Duration of the short circuit should not be greater than one second.
- Minimum DC voltage on input or I/O pins is -0.5 V. During voltage transitions, inputs may undershoot V<sub>ss</sub> to -1.0V for periods of up to 50ns and to -2.0 V for periods of up to 20ns. See figure below. Maximum DC voltage on output and I/O pins is V<sub>cc</sub> + 0.5 V. During voltage transitions, outputs may overshoot to V<sub>cc</sub> + 1.5 V for periods up to 20ns. See figure below.

## RECOMMENDED OPERATING RANGES <sup>1</sup>

Parameter	Value	Unit
Ambient Operating Temperature Industrial Devices	-40 to 85	C
Operating Supply Voltage V <sub>cc</sub>	Full: 2.7 to 3.6	V

Notes:

- Recommended Operating Ranges define those limits between which the functionality of the device is guaranteed.

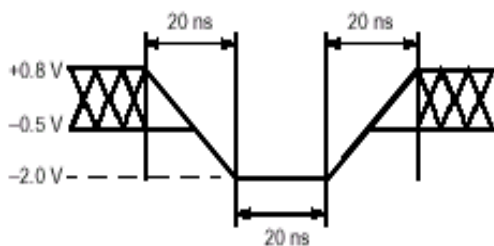

Maximum Negative Overshoot Waveform

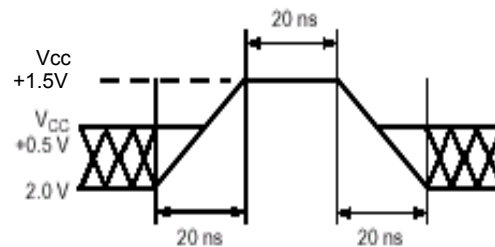

Maximum Positive Overshoot Waveform



Table 15. DATA RETENTION and ENDURANCE

Parameter Description	Test Conditions	Min	Unit
Data Retention Time	150°C	10	Years
	125°C	20	Years
Erase/Program Endurance	-40 to 85 °C	100k	cycles

Table 16. CAPACITANCE

(V<sub>CC</sub> = 2.7-3.6V)

Parameter Symbol	Parameter Description	Test Setup	Max	Unit
C <sub>IN</sub>	Input Capacitance	V <sub>IN</sub> = 0	6	pF
C <sub>OUT</sub>	Output Capacitance	V <sub>OUT</sub> = 0	8	pF

**Note** : Sampled only, not 100% tested, at T<sub>A</sub> = 25°C and a frequency of 20MHz.

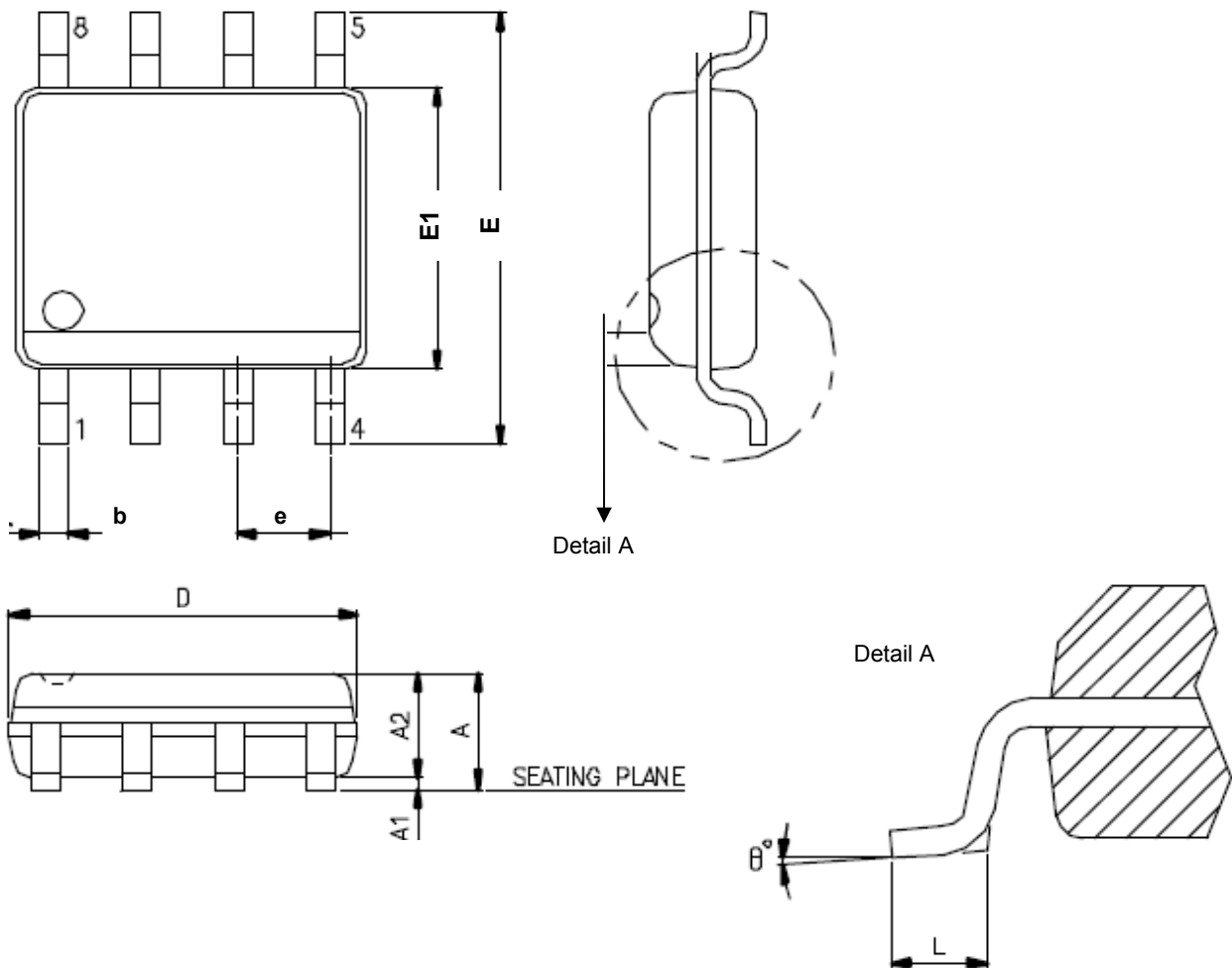
**PACKAGE MECHANICAL**
**Figure 33. SOP 8 ( 150 mil )**

SYMBOL	DIMENSION IN MM		
	MIN.	NOR	MAX
A	1.35	---	1.75
A1	0.10	---	0.25
A2	---	---	1.50
D	4.80	---	5.00
E	5.80	---	6.20
E1	3.80	---	4.00
e	---	1.27	---
b	0.33	---	0.51
L	0.4	---	1.27
$\theta$	$0^{\circ}$	---	$8^{\circ}$

Note : 1. Coplanarity: 0.1 mm  
 2. Max. allowable mold flash is 0.15 mm  
 at the pkg ends, 0.25 mm between leads.

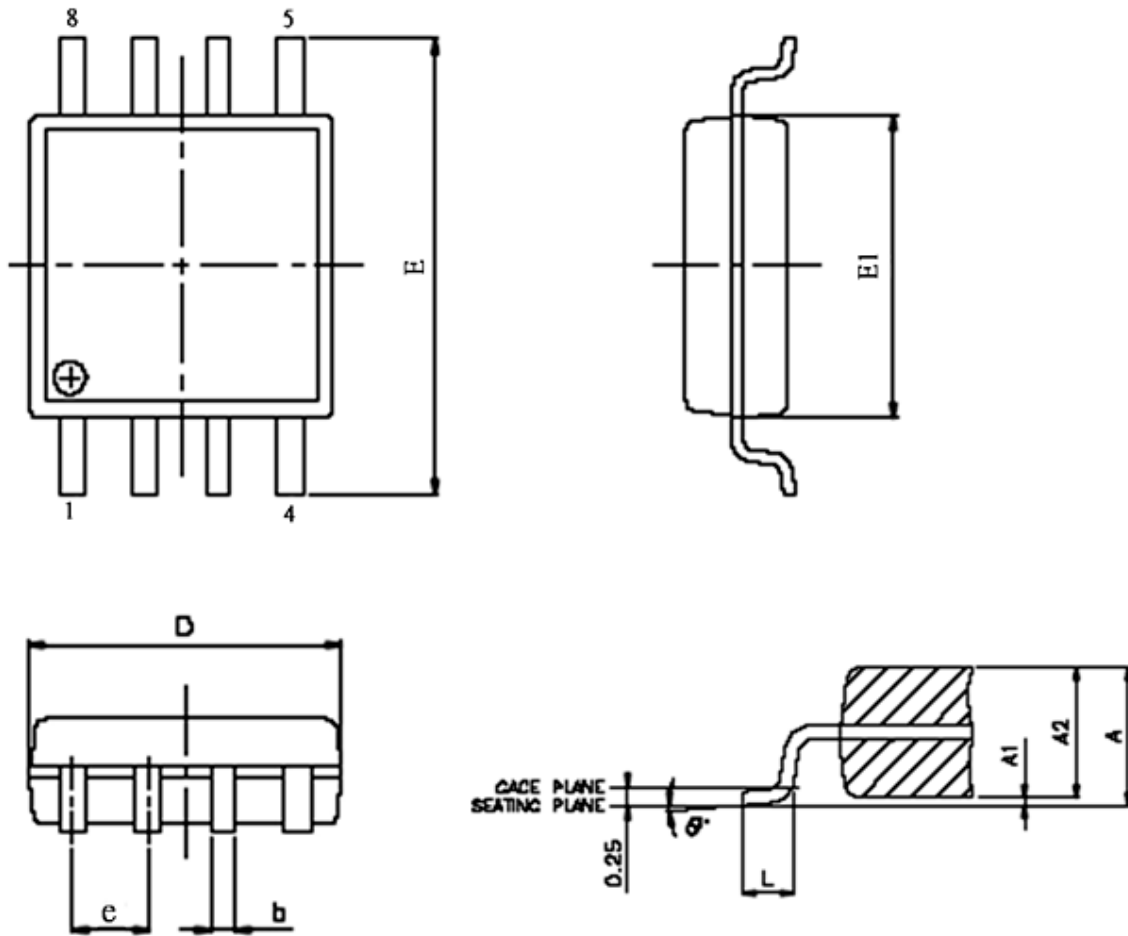
**Figure 34. SOP 200 mil ( official name = 208 mil )**

SYMBOL	DIMENSION IN MM		
	MIN.	NOR	MAX
A	1.75	1.975	2.20
A1	0.05	0.15	0.25
A2	1.70	1.825	1.95
D	5.15	5.275	5.40
E	7.70	7.90	8.10
E1	5.15	5.275	5.40
e	---	1.27	---
b	0.35	0.425	0.50
L	0.5	0.65	0.80
$\theta$	$0^{\circ}$	$4^{\circ}$	$8^{\circ}$

Note : 1. Coplanarity: 0.1 mm  
 2. Max. allowable mold flash is 0.15 mm  
 at the pkg ends, 0.25 mm between leads.

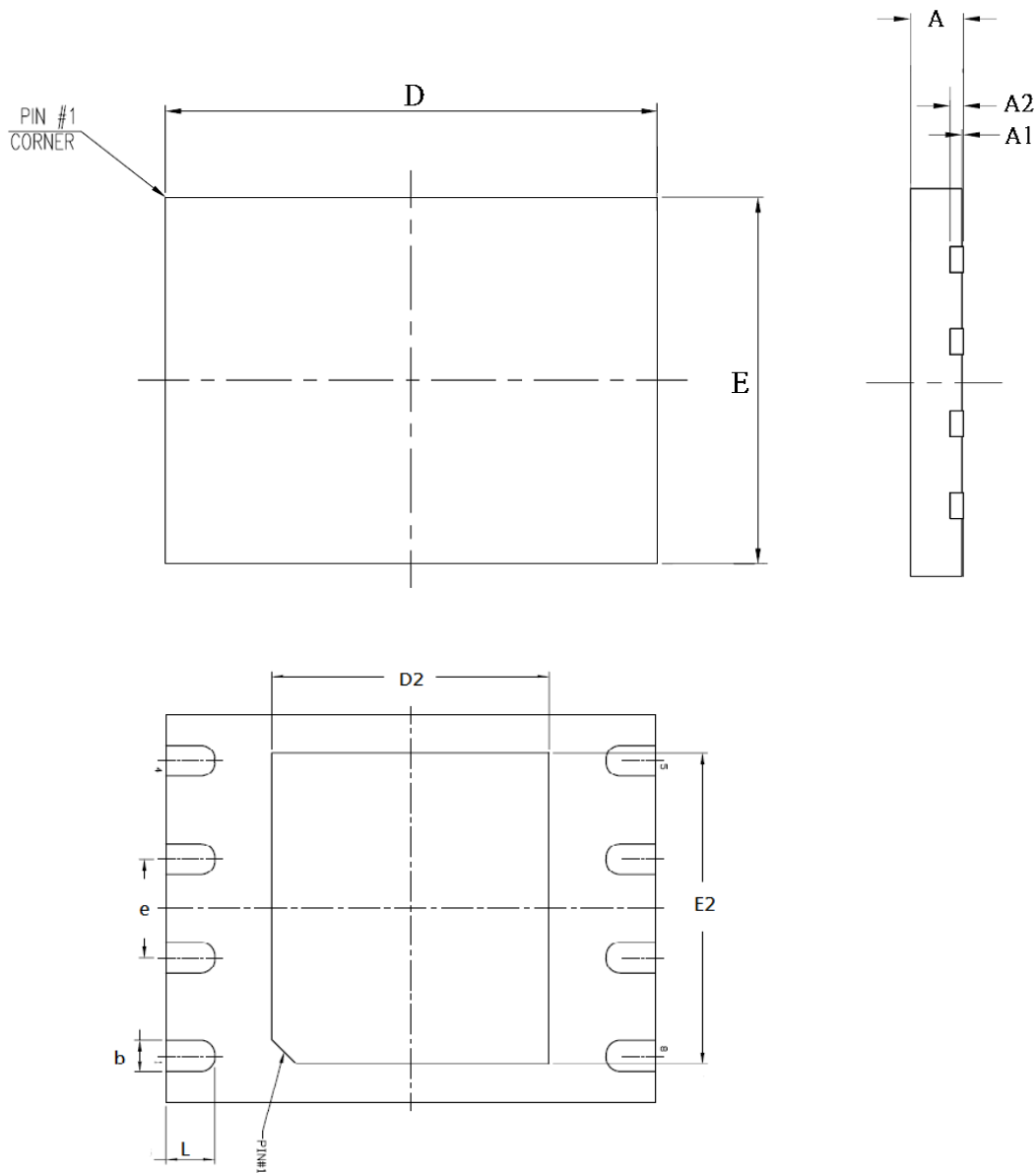
**Figure 35. VDFN 8 ( 5x6 mm )**

**Controlling dimensions are in millimeters (mm).**

SYMBOL	DIMENSION IN MM		
	MIN.	NOR	MAX
A	0.70	0.75	0.80
A1	0.00	0.02	0.04
A2	---	0.20	---
D	5.90	6.00	6.10
E	4.90	5.00	5.10
D2	3.30	3.40	3.50
E2	3.90	4.00	4.10
e	---	1.27	---
b	0.35	0.40	0.45
L	0.55	0.60	0.65

**Note : 1. Coplanarity: 0.1 mm**

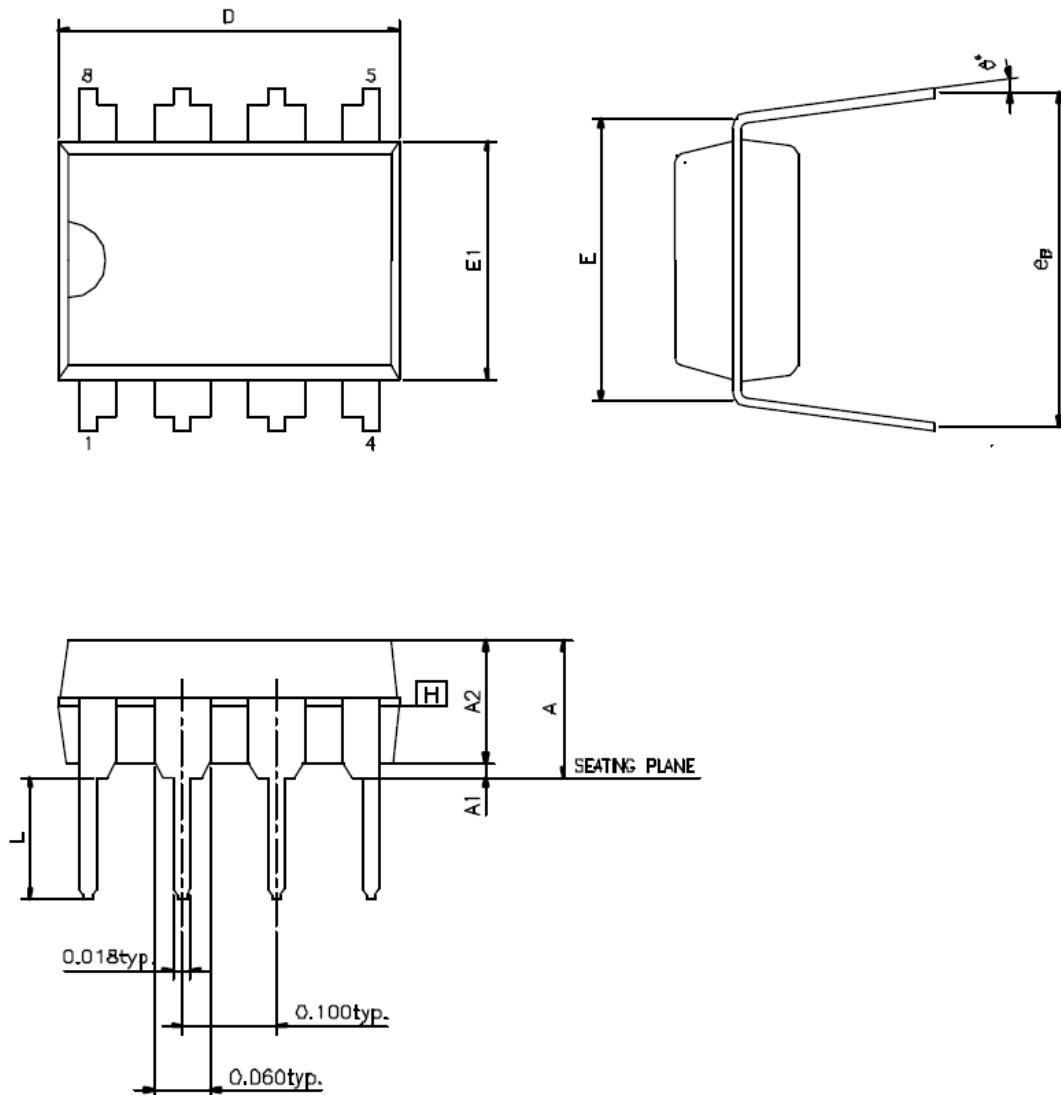
**Figure 36. PDIP8**

SYMBOL	DIMENSION IN INCH		
	MIN.	NOR	MAX
A	---	---	0.210
A1	0.015	---	---
A2	0.125	0.130	0.135
D	0.355	0.365	0.400
E	0.300	0.310	0.320
E1	0.245	0.250	0.255
L	0.115	0.130	0.150
$e_B$	0.310	0.350	0.375
$\theta^0$	0	7	15

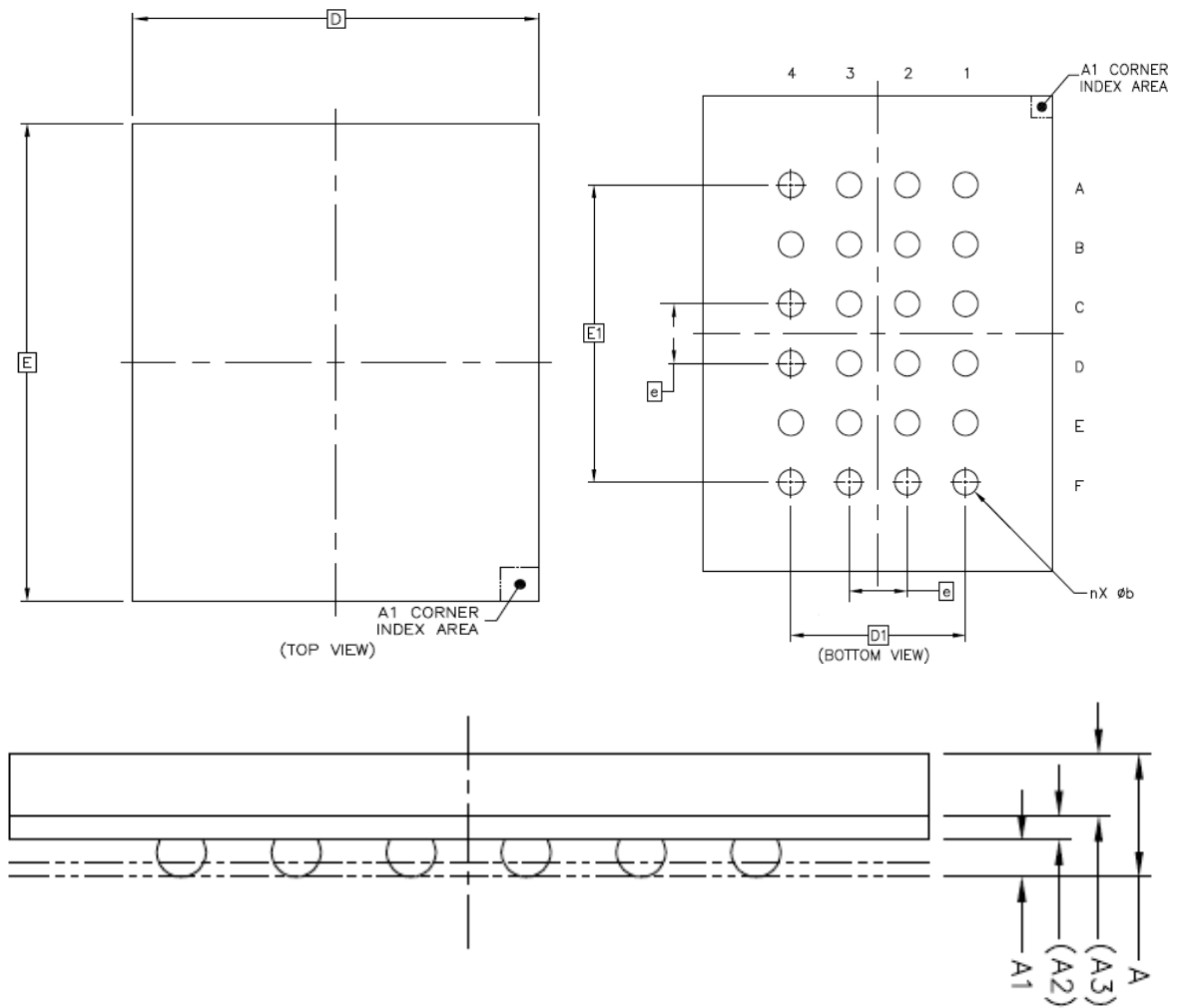
**Figure 37. 24-ball Thin Profile Fine-Pitch Ball Grid Array (6 x 8 mm) Package**

SYMBOL	DIMENSION IN MM		
	MIN	NOM	MAX
A	---	---	1.20
A1	0.27	---	0.37
A2	0.21 REF		
A3	0.54 REF		
D	6 BSC		
E	8 BSC		
D1	---	300	---
E1	---	500	---
e	---	1.00	---
b	---	0.40	---



## Purpose

Eon Silicon Solution Inc. (hereinafter called "Eon") is going to provide its products' top marking on ICs with < cFeon > from January 1<sup>st</sup>, 2009, and without any change of the part number and the compositions of the Ics. Eon is still keeping the promise of quality for all the products with the same as that of Eon delivered before. Please be advised with the change and appreciate your kindly cooperation and fully support Eon's product family.

## Eon products' Top Marking

**cFeon**

### cFeon Top Marking Example:

**cFeon**

**Part Number: XXXX-XXX**

**Lot Number: XXXXX**

**Date Code: XXXXX**

## For More Information

Please contact your local sales office for additional information about Eon memory solutions.



**ORDERING INFORMATION**

EN25QH16 - 104 H I P

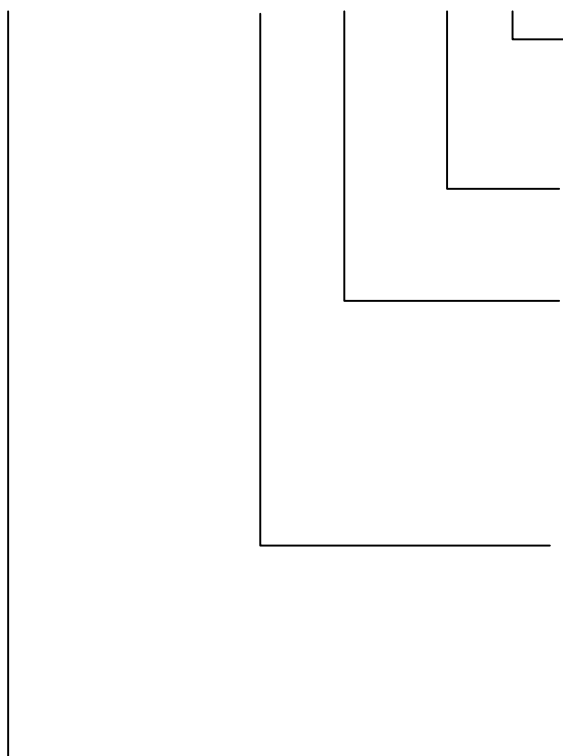

**PACKAGING CONTENT**

P = RoHS compliant

**TEMPERATURE RANGE**

I = Industrial (-40°C to +85°C)

**PACKAGE**

- G = 8-pin 150mil SOP
- H = 8-pin 200mil SOP
- W = 8-pin VDFN (5x6mm)
- Q = 8-pin PDIP
- BB = 24-ball TFBGA (6 x 8 x 1.2mm)

**SPEED**

104 = 104 MHz

**BASE PART NUMBER**

EN = Eon Silicon Solution Inc.  
25QH = 3V Serial Flash with 4KB Uniform-Sector,  
Dual and Quad I/O  
16 = 16 Megabit (2048K x 8)



## Revisions List

Revision No	Description	Date
A	Initial Release	2010/12/23
B	Rename 38h command from Enable Quad I/O (EQIO) to Enable Quad Peripheral Interface mode (EQPI).	2011/01/03
C	Update Write Status Register Cycle Time from 10 (typ.) /15 (max.) ms to 15 (typ.) / 30 (max.) ms on page 50.	2011/01/19
D	Update Table 3. Protected Area Sizes Sector Organization on page 11.	2011/01/25
E	1. Update Read SFDP Mode and Unique ID Number (5Ah) description on page 43. 2. Update Write Status Register Cycle Time (max.) from 30 ms to 50 ms on page 50. 3. Rename 24 Ball package from BGA to TFBGA.	2011/04/15
F	1. Add the note "5. This flow cannot release the device from Deep power down mode." on page 16. 2. Correct the typo of 6 dummy clocks for EBh command on page 27. 3. Update Read SFDP Mode and add Unique ID Number (5Ah) description on page 43.	2011/06/01
G	1. Update Figure 2. BLOCK DIAGRAM on page 4. 2. Update the Serial Flash Discoverable Parameters (SFDP) table on page 44, 45, 46, 47 and 48.	2011/11/28
H	Update Unique ID Number from 64 bits to 96 bits on page 49.	2012/01/30
I	1. For the Table 6 Status Register, rename S6 bit from QE to WHDIS and revised its description on page 10, 19 and 20. 2. Update the description for Quad Input/Output FAST_READ (EBh) on page 27. 3. Revise the typo for Table 9. Parameter ID (0) (Advanced Information) 5/9 on page 47.	2012/06/01