



HT-CT

High Temperature Continuous Tube HEAT SHRINK IDENTIFICATION SYSTEM Technical Datasheet

TTDS-271 Revision 2 - September 2019

HT-CT High Temperature markers sleeve for identification of wires and cables, presented as a continuous tube.

HT-CT is manufactured using a specially developed radiation cross-linked material. Formulated to give high temperature performance and low out-gassing; this product has an operating temperature up to 225°C (437°F) suitable for many military and aerospace applications.

Thin walled HT-CT heat shrink tube, manufactured with e-beam technology gives users the ability to shrink the supplied tube with no damage to material or printed text. Shrinking the tube will ensure the printed marker has a firm hold on the wire.

HT-CT gives market leading print performance when used as a complete system, as recommended by TE Connectivity. Refer to TE document 411-121005 IDENTIFICATION PRINTER PRODUCT RIBBON MATRIX for the recommended printer/product/ribbon combinations.

HT-CT Heat Shrink Identification Marker Sleeving is available as part of a complete identification system. The system comprises specific printers, thermal transfer ribbons and WINTOTAL software.

HT-CT HIGH TEMPERATURE

HEAT SHRINK CABLE IDENTIFICATION SYSTEM

Features

- High Temperature
- Excellent chemical resistance.
- Flame retarded, Self Extinguishing, UL VW-1 rated.
- Resistant to key Aerospace, Military, Rail and Industrial fluids (defined by TE specification RW-2512)
- Sleeve diameters from 3/32 to 3/4inch (2.4mm to 19.0mm)
- Shrink ratio 2:1 (3/32 is 3:1)
- More open profile for easier use

Design for Environment

- HT-CT fully complies with 2011/65/EU RoHS II directive, and Regulation (EC) number 1907/2006 (REACH)
- Does not contain any declarable or prohibited substances from UNIFE Railway Industry Substance List.

Further information and a downloadable declaration covering RoHS and REACH compliance can be found at the TE Product Compliance Support Centre:

<http://www.te.com/usa-en/utilities/product-compliance.html>

Temperature Rating

- Operating Temperature Range -55°C to 225°C (-67°F to 437°F)

Applications



Specifications / Approvals

TE Connectivity Standard RW-2512

Rail Standards

EN45545-2, Railway applications - Fire protection on railway vehicles, Part 2: Requirements for fire behaviour of materials and components
Fire Hazard Classification 3, in accordance with requirement set R24.

NFPA 130 Standard for Fixed Guideway Transit and Passenger Rail Systems, Fire protection requirements, Interior Fire Propagation Resistance.

Federal Railroad Administration, DOT, Appendix B to Part 238, Test Methods and Performance Criteria for the Flammability and Smoke Emission Characteristics of Materials used in Passenger Cars and Locomotive Cabs.

Shazainennshi, Japan Railway Rolling Stock & Machinery Association 2003 Classification "Flame Retardant" Serial number 2015-167K.

Print Performance

- MIL 202J Method 215K, Resistance to Solvents.
- SAE AS 5942, Marking of Electrical Insulating Materials, Adherence.

Where possible, TE have tested product as a finished item, including the print. Operational tests are followed by an assessment of mark adherence to validate fit form and function. Further details can be found in TE standard RW-2512

HT-CT High Temperature

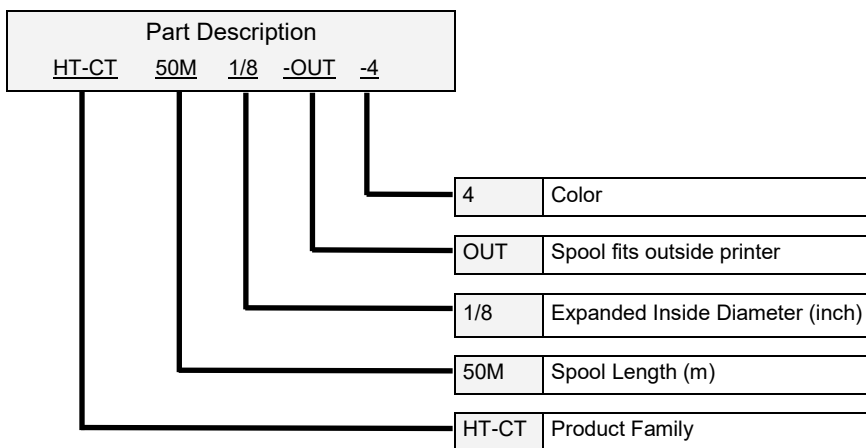

Available Options

Spool Size	OUT	Spool does not fit inside printers, recommend TE Connectivity PRINTER-UNIVERSAL-REEL-HOLDER, Part Number EC9926-000, reference TTDS-259						
Colors	Standard	Yellow	White					
	Code	4	9					
	Other colors available on request							
	Brown	Red	Orange	Green	Blue	Violet	Grey	Black
	1	2	3	5	6	7	8	0

Ordering Example: HT-CT-50M-1/8-OUT-9

i.e. Specify Product Family, Spool Length, Expanded Inside Diameter, OUT and Color

Ordering Information

Ordering description	Inside diameter				Recommended cable diameter use range		Spool lengths m (ft)
	As supplied (minimum)		After recovery (Maximum)		mm	inches	
	mm	inches	mm	inches			
HT-CT - <spool length> -3/32 - OUT- <Color>	2.4 ¹	0.094	0.79	0.031	0.90 to 1.90	0.035 to 0.075	50 (164)
HT-CT - <spool length> -1/8 - OUT- <Color>	3.2 ¹	0.125	1.6	0.063	1.77 to 2.56	0.067 to 0.101	50 (164)
HT-CT - <spool length> -3/16 - OUT- <Color>	4.8 ¹	0.189	2.4	0.094	2.54 to 4.06	0.098 to 0.151	50 (164)
HT-CT - <spool length> -1/4 - OUT- <Color>	6.4 ¹	0.250	3.2	0.126	3.81 to 5.46	0.130 to 0.201	50 (164)
HT-CT - <spool length> -3/8 - OUT- <Color>	9.5 ¹	0.375	4.8	0.189	5.23 to 8.12	0.193 to 0.299	50 (164)
HT-CT - <spool length> -1/2 - OUT- <Color>	12.7 ¹	0.500	6.4	0.250	6.99 to 10.8	0.256 to 0.402	50 (164)
HT-CT - <spool length> -3/4 - OUT- <Color>	19.1 ²	0.750	9.5	0.375	10.2 to 16.3	0.378 to 0.614	50 (164)

¹ Recommended ribbon width 40mm— TMS-RJS-RIBBON-4HT-NAR, Part No. 1-2186496-1

² Recommended ribbon width 60mm— TMS-RJS-RIBBON-4HT-MED, Part No. 1-2186491-1

Check TE Document 411-121005 for full and current details



Printer Information

Print quality and print performance can only be guaranteed when specific TE printer and ribbons are used.

The current list of printers and ribbons can be found in TE document 411-121005 'Identification Printer Product Ribbon Matrix'. This document can be found in 'Access Our Tools':

<http://www.te.com/usa-en/utilities/access-product-tools-and-resources.html>

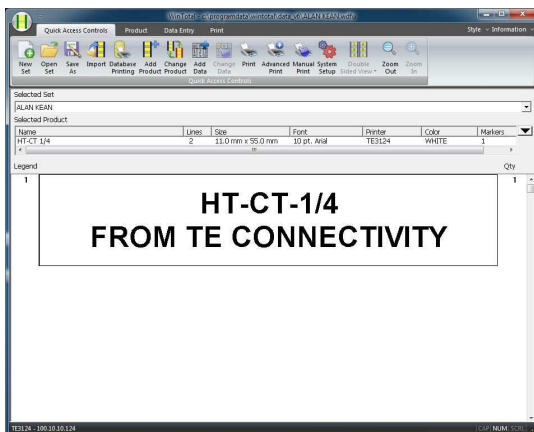

Software

WINTOTAL software, available to download for a 14 day evaluation period from the Identification Printer Software page:

www.te.com/wintotal

Contact a TE representative for further information

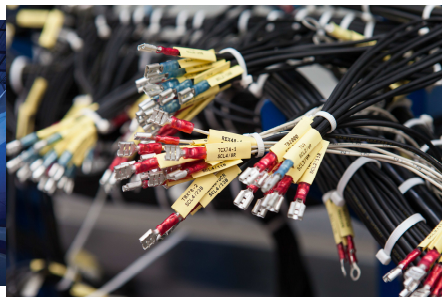
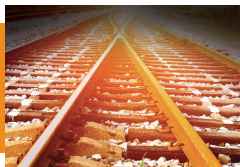

www.te.com/rail

TE Connectivity, TE Connectivity (logo) and Every Connection Counts are trademarks. All other logos, products and/or company names referred to herein might be trademarks of their respective owners.

The information given herein, including drawings, illustrations and schematics which are intended for illustration purposes only, is believed to be reliable. However, TE Connectivity makes no warranties as to its accuracy or completeness and disclaims any liability in connection with its use. TE Connectivity's obligations shall only be as set forth in TE Connectivity's Standard Terms and Conditions of Sale for this product and in no case will TE Connectivity be liable for any incidental, indirect or consequential damages arising out of the sale, resale, use or misuse of the product. Users of TE Connectivity products should make their own evaluation to determine the suitability of each such product for the specific application.

© 2018 TE Connectivity Ltd. family of companies All Rights Reserved.

