

The ECX-33Q is a miniature SMD Crystal with a 3.2 x 2.5 mm footprint. AEC-Q200 Qualified.

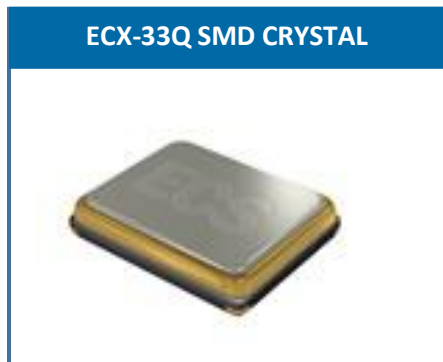

- Low Profile
- 3.2 x 2.5 mm Footprint
- RoHS Compliant
- AEC-Q200 Qualified

OPERATING CONDITIONS / ELECTRICAL CHARACTERISTICS

PARAMETERS	CONDITIONS	ECX-33Q			UNITS
		MIN	TYP	MAX	
Frequency		12.000		40.000	MHz
Mode of Oscillation	Fundamental				
Frequency Tolerance*	@ +25°C			± 30	ppm
Frequency Stability*	-55 ~ +125°C (DU Option)			± 100	ppm
Shunt Capacitance	Co			7	pF
Load Capacitance	Specify in P/N	10	20	Series	pF
Drive Level	DL			100	μW
Operating Temperature*	T _{opr} (DU Option)	-55		+125	°C
Storage Temperature	T _{stg}	-55		+125	°C
Aging (First Year)	@ +25°C ±3°C			±5	ppm

DIMENSIONS (mm)

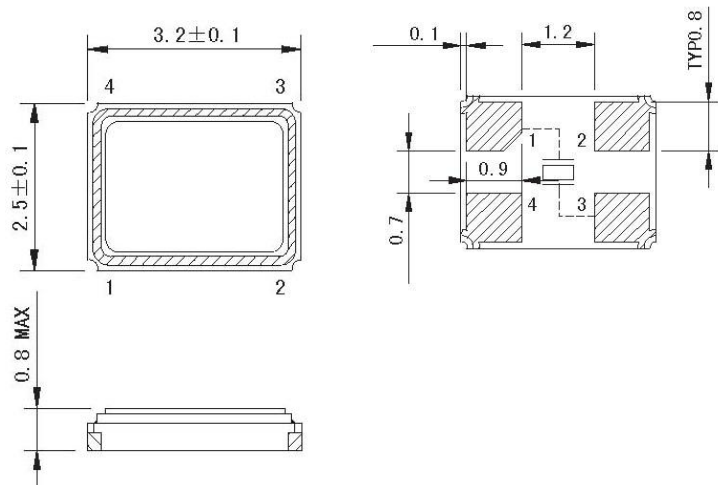

Figure 1) Top, Side, and Bottom

Crystal is symmetrical, pad 1 & 3 are interchangeable. Chamfer on the bottom pad has no electrical significance.

Frequency (MHz)	ESR Ω Max.
12.000 ~ 15.999	100
16.000 ~ 19.999	80
20.000 ~ 23.999	60
24.000 ~ 40.000	40

Pad Connections	
1	In/Out
2	Gnd
3	Out/In
4	Gnd

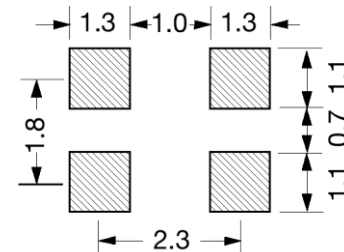

Figure 2) Suggested land

PART NUMBERING GUIDE: Example ECS-200-20-33Q-DU-TR

ECS - FREQUENCY ABBREVIATION	LOAD CAPACITANCE	PACKAGE	AVAILABLE OPTIONS			PACKAGING
			Tolerance	Stability	Temp Range	
ECS	200 = 20.000 MHz See P/N Guide	33Q = ECX-33Q	Blank = Std A = ± 25 ppm J = ± 20 ppm R = ± 15 ppm C = ± 10 ppm	Blank = Std D = ± 100 ppm E = ± 50 ppm G = ± 30 ppm H = ± 25 ppm T = ± 20 ppm † W = ± 15 ppm † K = ± 10 ppm †	Blank = Std L = -10 ~ +70°C M = -20 ~ +70°C Y = -30 ~ +85°C N = -40 ~ +85°C P = -40 ~ +105°C S = -40 ~ +125°C U = -55 ~ +125°C	TR = Tape & Reel 1K/Reel

* Specify available options in P/N.

† Contact ECS for availability over extended temp range.

Rev.2017

POCKET TAPE DIMENSIONS (mm)

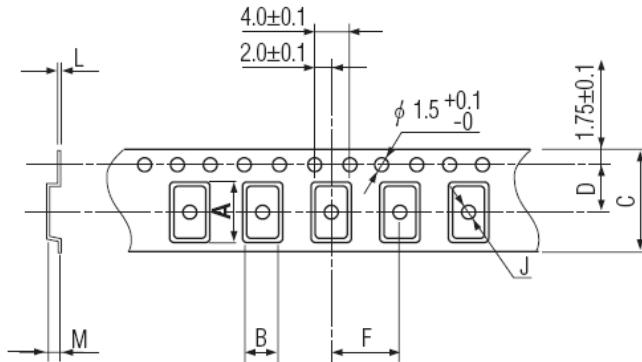

A	B	C	D	F	J	L	M	Reel Dia.	Qty/Reel
3.5	2.8	8.0	3.5	4.0	1.1	0.25	1.0	180	1000

SOLDER PROFILE	
Peak solder Temp +260°C Max 10 sec Max.	
2 Cycles Max.	
MSL 1, Lead Finish Au	

DEVELOPED FREQUENCIES	
Abbreviation	Frequency (MHZ)
120	12.000
122.8	12.288
130	13.000
135.6	13.560
143	14.31818
147.4	14.7456
160	16.000
163.84	16.384
184	18.432
196.6	19.6608
200	20.000
221	22.1184
240	24.000
245.7	24.576
250	25.000
260	26.000
270	27.000
286.3	28.63636
300	30.000
320	32.000
330	33.000
400	40.000

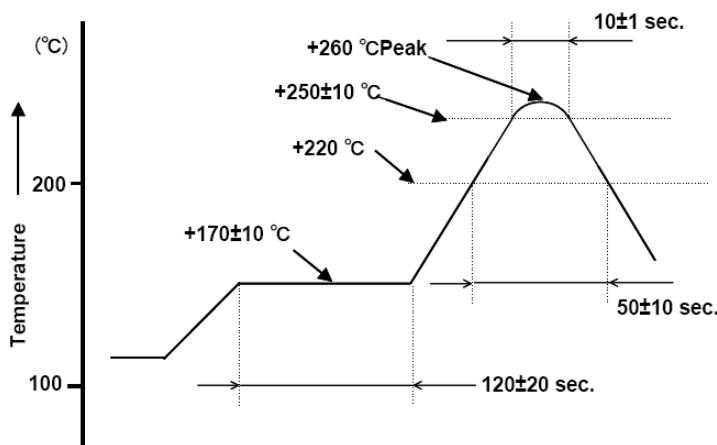

Figure 1) Suggested Reflow Profile